

MARY ESCRIVANINHA

MARY OFFICE DESK

MARY ESCRITORIO

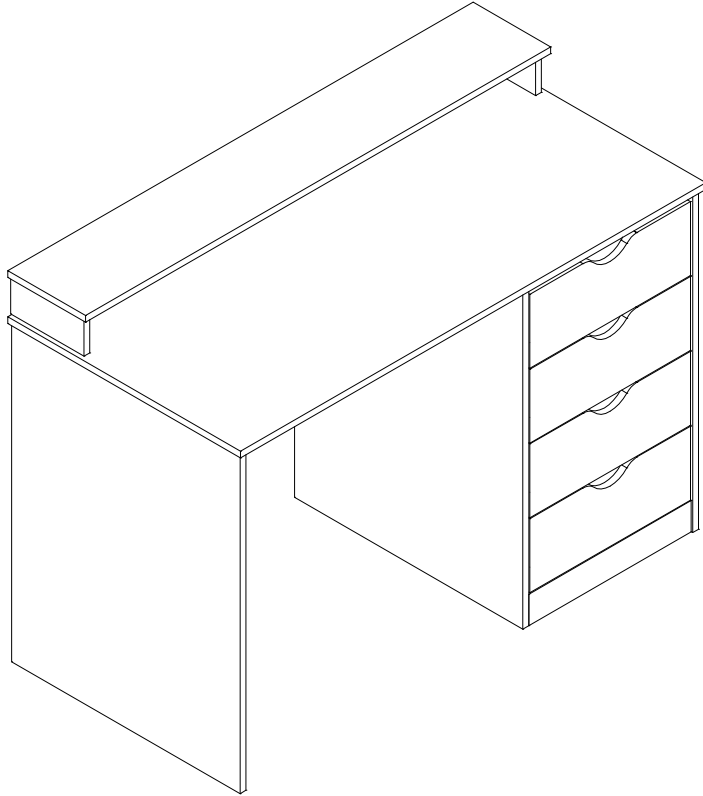

VÍDEO DE INSTRUÇÕES DE MONTAGEM
ASSEMBLY INSTRUCTIONS VIDEO
VÍDEO DE INSTRUÇÕES DE MONTAGEM

MÚSICAS PARA OUVIR ENQUANTO VOCÊ MONTA O SEU MÓVEL
SONGS TO LISTEN TO WHILE YOU ASSEMBLING YOUR FURNITURE
CANCIONES PARA ESCUCHAR MIENTRAS MONTAS TUS MUEBLES



ABRA O SPOTIFY E ESCANEIE O CÓDIGO
OPEN SPOTIFY AND SCAN THE CODE
ABRE EL SPOTIFY Y ESCANEA EL CÓDIGO



INSTRUÇÕES DE MONTAGEM

ASSEMBLY INSTRUCTIONS / INSTRUCCIONES DE MONTAJE



2x
pessoas necessárias
necessary people
gente necesaria



difícil
difficult
difícil
grau de dificuldade
difficulty level
nivel de dificultad

O grau de dificuldade de montagem desse produto é nível elevado.
Nesse caso, sugerimos a contratação de um profissional.

The level of difficulty in assembling this product is high. In this case, we suggest that you hire a professional.

El nivel de dificultad en el montaje de este producto es alto. En este caso, le sugerimos que contrate a un profesional.

FERRAMENTAS NECESSÁRIAS (não fornecidas)

NECESSARY TOOLS (not included) / HERRAMIENTAS NECESARIAS (no incluidas)

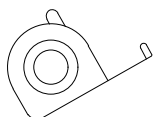

Fita Métrica
Measuring Tape
Cinta Métrica

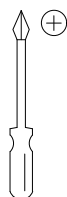

Chave Phillips
Phillips Screwdriver
Destornillador Phillips

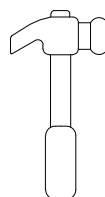

Martelo
Hammer
Martillo

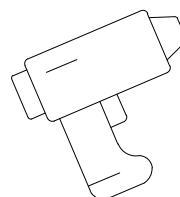

Furadeira
Power drill
Taladro



Ponteira Phillips
Phillips Tip
Punta Phillips

ANTES DE COMEÇAR A MONTAGEM, ALGUMAS DICAS!

BEFORE YOU BEGIN THE ASSEMBLY, SOME TIPS!

ANTES DE COMENZAR EL MONTAJE, ¡ALGUNOS CONSEJOS!

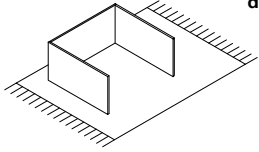

Deve-se fazer a montagem do módulo em cima de uma superfície macia, como um tapete.

The module must be mounted above soft surface, such as a carpet.

El módulo debe montarse sobre una superficie blanda, como una alfombra.

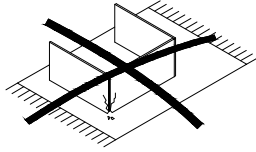

Evite danificar o produto com impactos ou objetos cortantes.

Avoid damaging the product with impacts or sharp objects.

Evite danificar el producto con impactos u objetos cortantes.

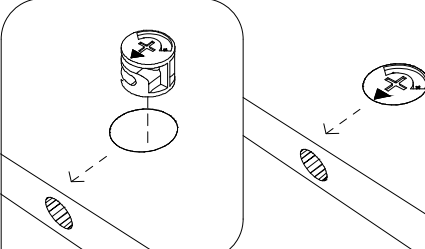

Alinhe a seta na superfície do Tambor (C) com a furação lateral da peça.

Align the arrow on the surface of the minifix housing (C) with the hole on the side of the part.

Alinee la flecha en la superficie de la cajita (C) con el orificio en el costado de la pieza.

Posicionamento do tambor do minifix
Minifix housing placement
Posicionamiento de la cajita minifix

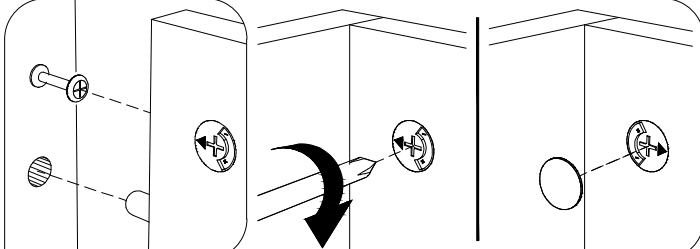

Aperte o tambor do minifix com pressão
Tighten the minifix housing with pressure
Apriete la cajita minifix con presión

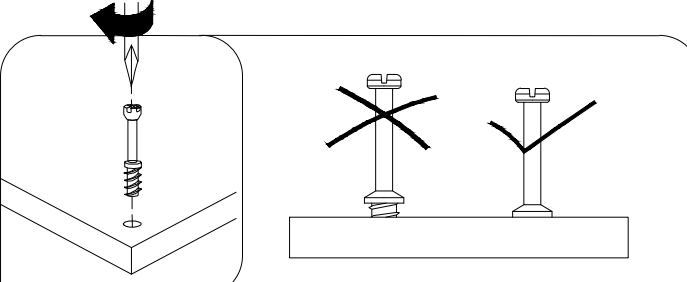

Parafuse o minifix até o final
Screw the minifix bolt all the way in
Atornille completamente la cajita minifix

Parafuse o minifix até o final
Screw the minifix bolt all the way in
Atornille completamente la cajita minifix

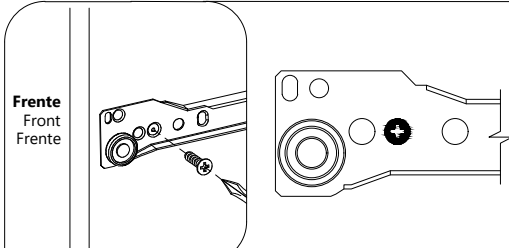

Fixar o parafuso no segundo furo.

Fix the screw in the second hole.

Fijar el tornillo en el segundo agujero.

Fixação da corredeira
Slide fixing
Fijación de la corredera

 **Utilize cola para evitar a queda das frentes das gavetas**
Use glue to prevent drawer fronts from falling
Utilice pegamento para evitar que se caigan los frentes de los cajones

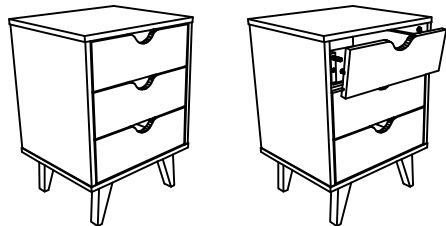

**Imagem meramente ilustrativa / *Merely illustrative image / *Imagen meramente ilustrativa*



IMPORTANTE :
Aguardar 4 horas para secagem.

WARNING:
Wait 4 hours for the glue dry.

ADVERTENCIA:
Esperar 4 horas a que se seque el pegamento.

Partes do módulo

Module parts

Partes del módulo

- 1** Tampo (1x)
Top (1x) / Tapa (1x)
- 2** Base (1x)
Base (1x) / Base (1x)
- 3** Lateral esquerda (1x)
Left Side (1x) / Lateral izquierdo (1x)
- 4** Lateral direita (1x)
Right Side (1x) / Lateral derecho (1x)
- 5** Fundo (1x)
Bottom (1x) / Fondo (1x)
- 6** Travessa pé (2x)
Leg's board (2x) / Tabla de las patas (2x)
- 7** Pés (4 x)
Feet (4x) / Pies (4x)

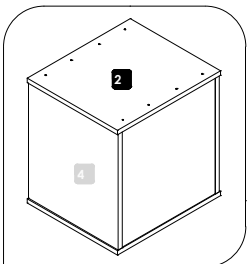
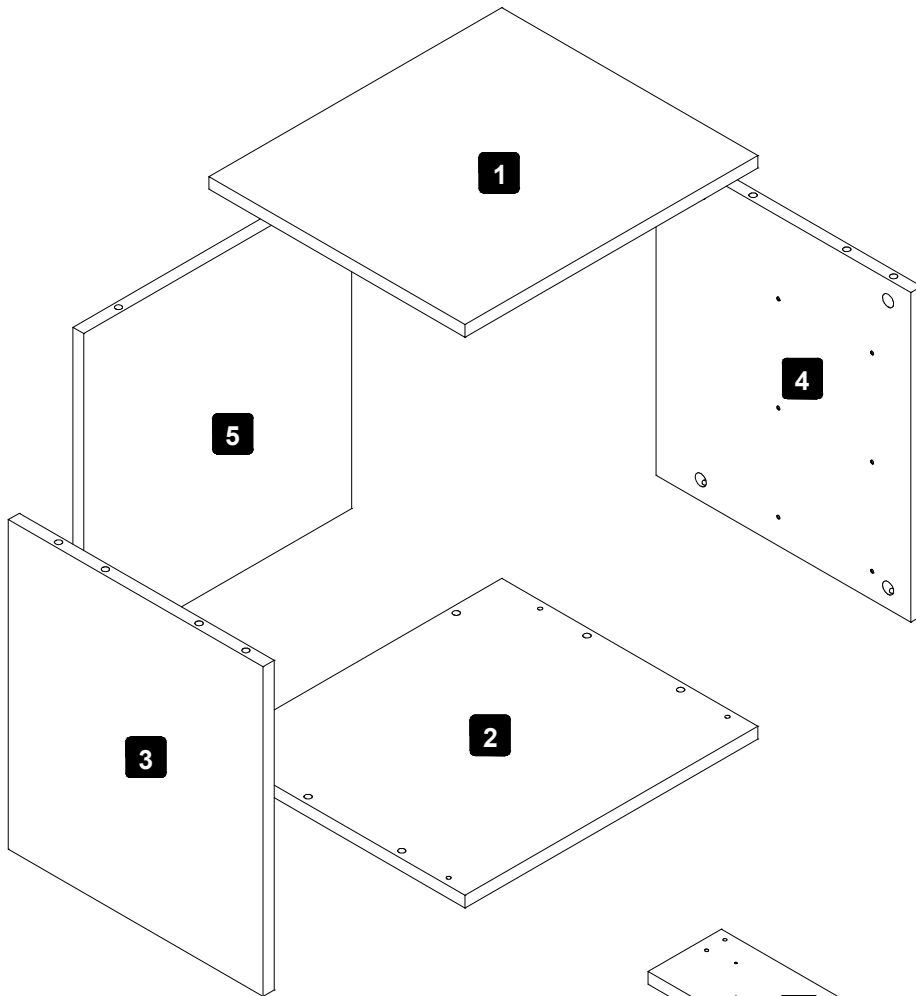

A base (2) possui esta marcação na vista inferior para fixação da travessa de pé (11)

The base (2) has this marking on the bottom view for fixing the foot rail (11)

La base (2) tiene esta marca en la vista inferior para fijar la travessa de pie (11)

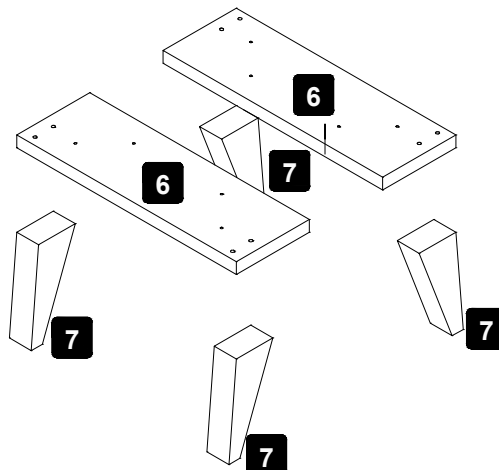

Partes da gaveta

Drawer parts

Partes del cajón

- 12** Lateral esquerda gaveta (4x)
Left side drawer (4x) / Lateral izquierda gaveta B (4x)
- 13** Lateral direita gaveta (4x)
Right side drawer (4x) / Lateral derecho gaveta B (4x)
- 14** Fundo da gaveta (4x)
Drawer bottom (4x) / Fondo de cajón (4x)
- 15** Frente da gaveta (4x)
Drawer front (4x) / Frente de cajón (4x)
- 16** Base da gaveta (4x)
Drawer stand (4x) / Base de cajón (4x)

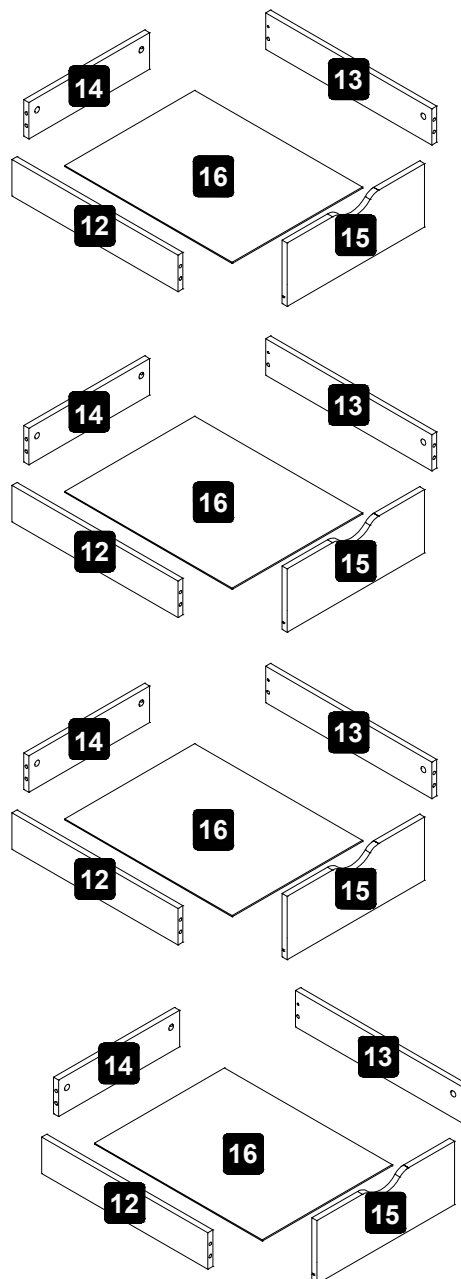

Componentes do módulo

Module components

Componentes del módulo



A. Cavilha 8x30mm (37x)
A. Peg 8x30mm (37x)
A. Espiga 8x30mm (37x)

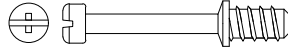

B. Minifix (24x)
B. Minifix (24x)
B. Minifix (24x)

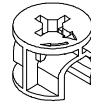

C. Tambor (24x)
C. Drum (24x)
C. Tambor (24x)

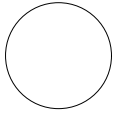

D. Tampa Tambor (24x)
D. Minifix Housing Cover (24x)
D. Tapa Cajita Minifix (24x)

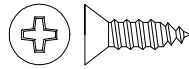

E. Parafuso Ø4x14mm (16x)
E. Screw Ø4x14mm (16x)
E. Tornillo Ø4x14mm (16x)

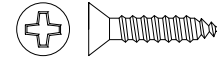

F. Parafuso Ø3,5x20mm (6x)
F. Screw Ø3,5x20mm (6x)
F. Tornillo Ø3,5x20mm (6x)



G. Sapata (6x)
G. Foot (6x)
G. Pie (6x)

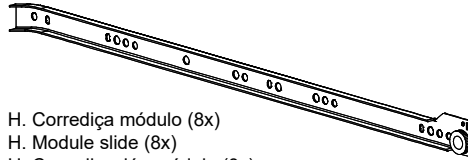

H. Corrediça módulo (8x)
H. Module slide (8x)
H. Corredización módulo (8x)

Utilizar a régua abaixo para medir os componentes.

Use the ruler below to measure the components.

Usa la regla abajo para medir los componentes.

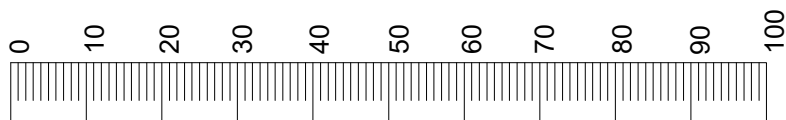

medidas em milímetros
measurements in millimeters
medidas en milímetros

Componentes da gaveta

Drawer components

Componentes del cajón



- A. Cavilha 8x30mm (16x)
- A. Peg 8x30mm (16x)
- A. Espiga 8x30mm (16x)

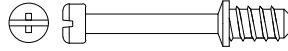

- B. Minifix (16x)
- B. Minifix (16x)
- B. Minifix (16x)



- C. Tambor (16x)
- C. Drum (16x)
- C. Tambor (16x)

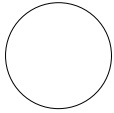

- D. Tampa Tambor (16x)
- D. Minifix Housing Cover (16x)
- D. Tapa Cajita Minifix (16x)

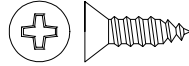

- E. Parafuso Ø4x14mm (16x)
- E. Screw Ø4x14mm (16x)
- E. Tornillo Ø4x14mm (16x)

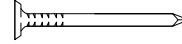

- I. Prego (52x)
- I. Nail (52x)
- I. Clavo (52x)

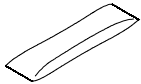

- J. Cola (1x)
- J. Glue (1x)
- J. Pegamento (1x)

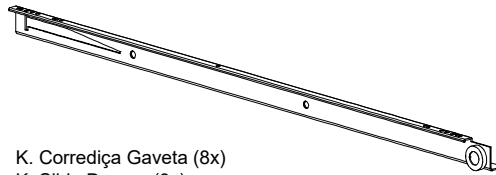

- K. Corrediça Gaveta (8x)
- K. Slide Drawer (8x)
- K. Corredera Cajón (8x)

Utilizar a régua abaixo para medir os componentes.

Use the ruler below to measure the components.

Usa la regla abajo para medir los componentes.

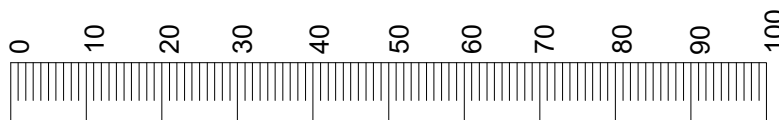

medidas em milímetros
measurements in millimeters
medidas en milímetros

Pré montagem do módulo
Pre-assembly of the module
Premontaje del módulo

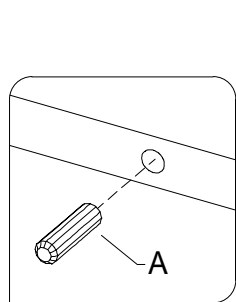
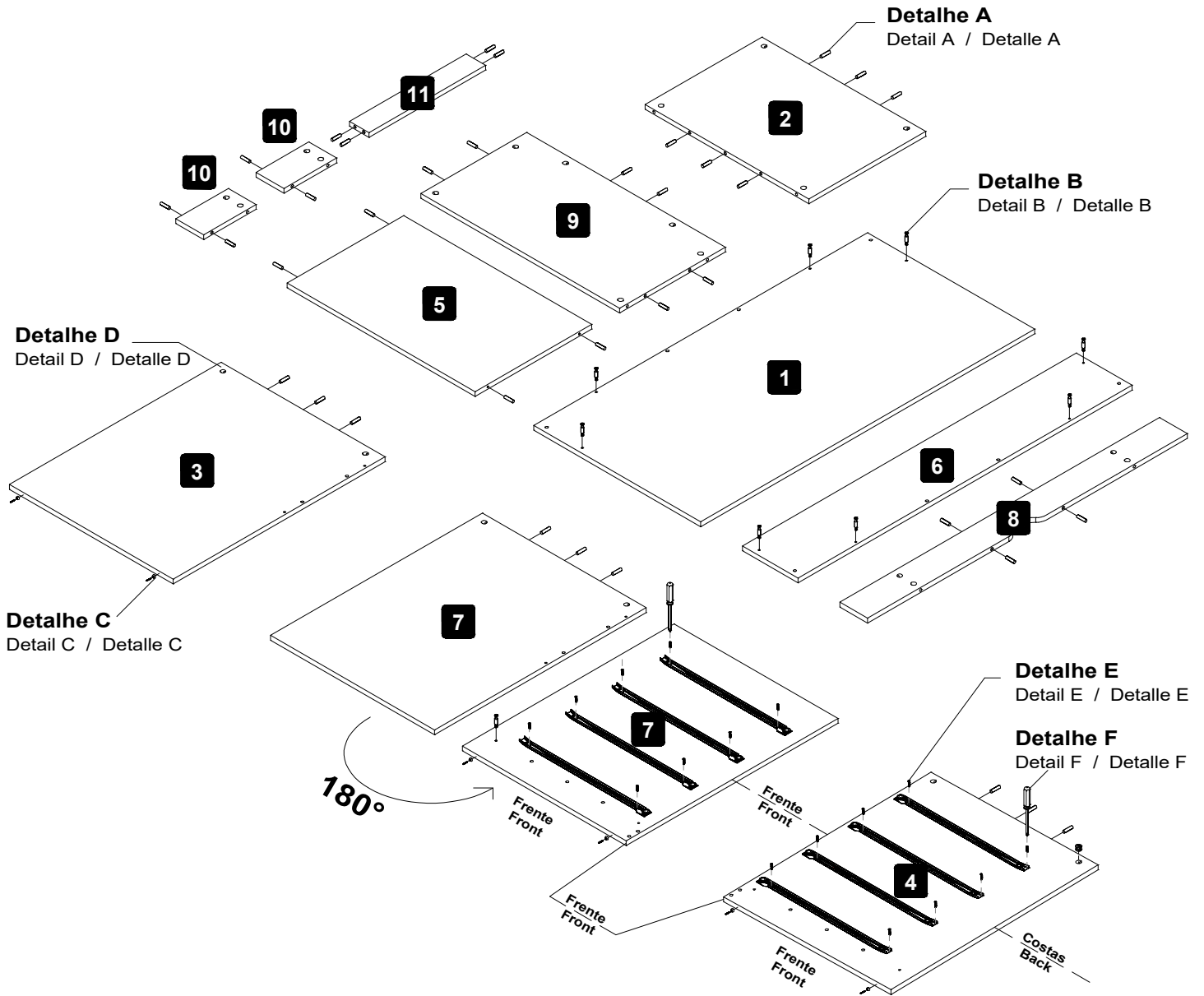

Detalhe A
Detail A / Detalle A

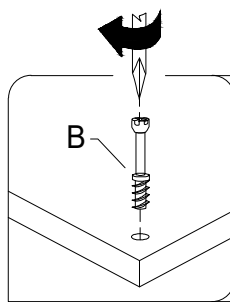

Detalhe B
Detail B / Detalle B

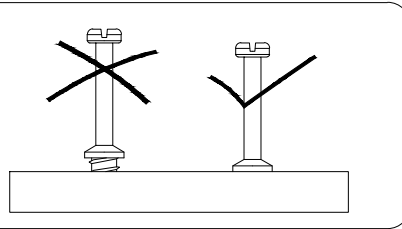

Detalhe C
Detail C / Detalle C

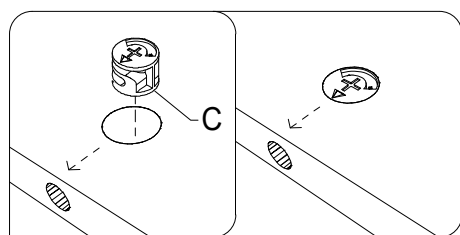
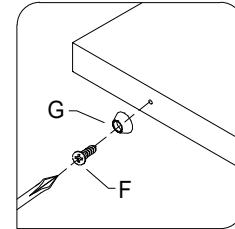

Detalhe D
Detail D / Detalle D

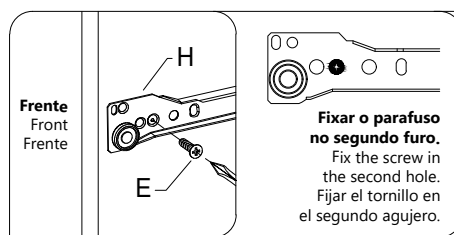

Detalhe E
Detail E / Detalle E

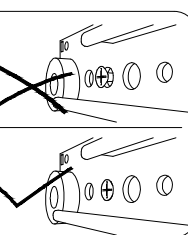

Fixar o parafuso no segundo furo.
Fix the screw in the second hole.
Fijar el tornillo en el segundo agujero.

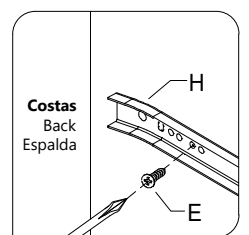

Detalhe F
Detail F / Detalle F

01

Partes do módulo

Module parts

Partes del módulo

- 2** Base (1x)
Base (1x) / Base (1x)
- 3** Lateral esquerda (1x)
Left Side (1x) / Lateral izquierdo (1x)
- 4** Lateral direita (1x)
Right Side (1x) / Lateral derecho (1x)
- 5** Fundo (1x)
Bottom (1x) / Fondo (1x)

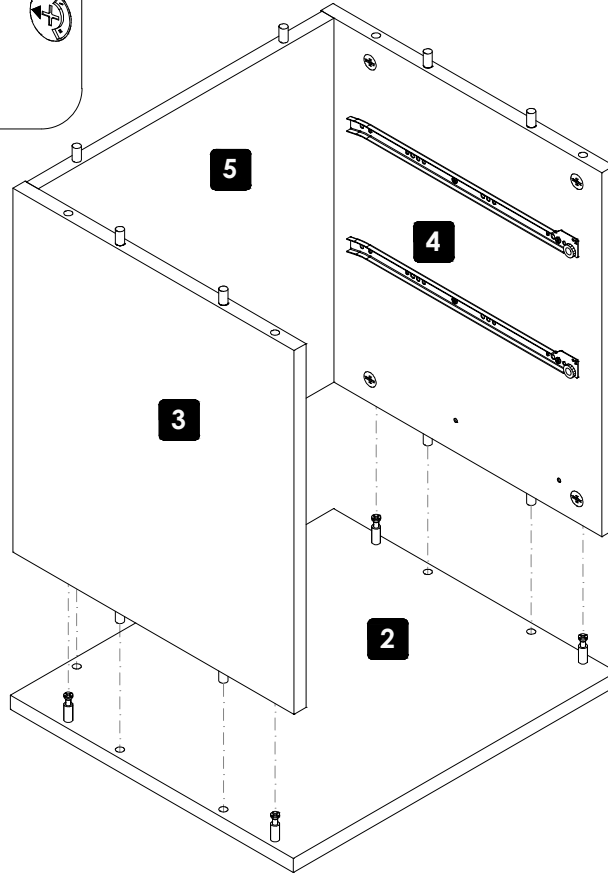
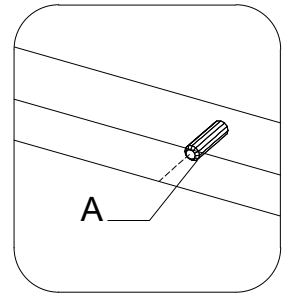
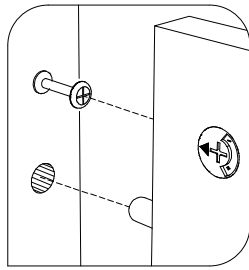

Ferramentas necessárias

Required tools

Herramientas requeridas

Componentes do módulo

Module components

Componentes del módulo

02

Partes do módulo

Module parts

Partes del módulo

Ferramentas necessárias

Required tools

Herramientas requeridas

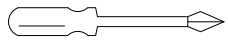

Chave Phillips
Phillips Screwdriver
Destornillador Phillips



Componentes do módulo

Module components

Componentes del módulo



- D. Tapa Tambor (4x)
- D. Minifix Housing Cover (4x)
- D. Tapa Cajita Minifix (4x)

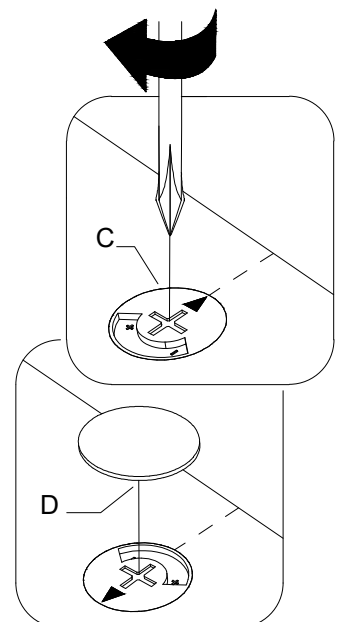
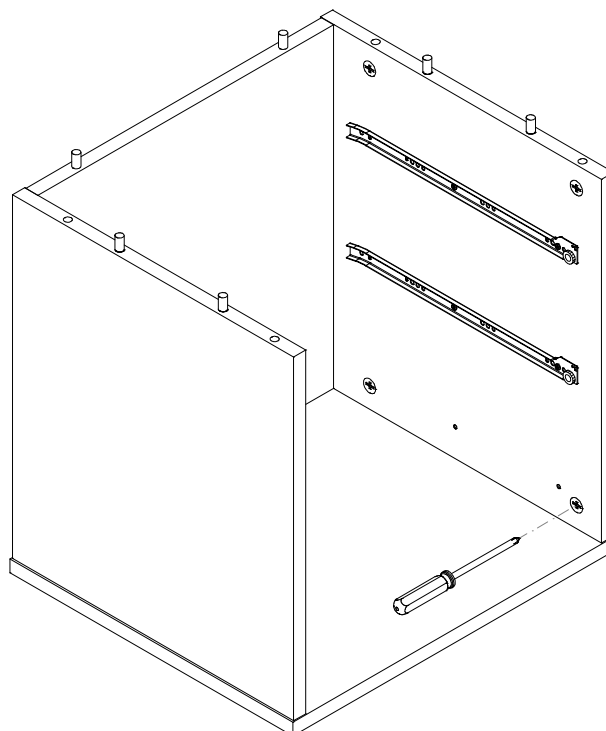

03

Partes do módulo

Module parts

Partes del módulo

Ferramentas necessárias

Required tools

Herramientas requeridas

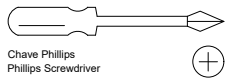

Chave Phillips
Phillips Screwdriver
Destornillador Phillips

Componentes do módulo

Module components

Componentes del módulo

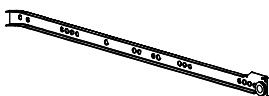

H. Corrediça módulo (2x)

H. Module slide (2x)

H. Corredización módulo (2x)

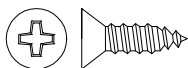

E. Parafuso Ø4x14 (4x)

E. Screw Ø4x14 (4x)

E. Tornillo Ø4x14 (4x)

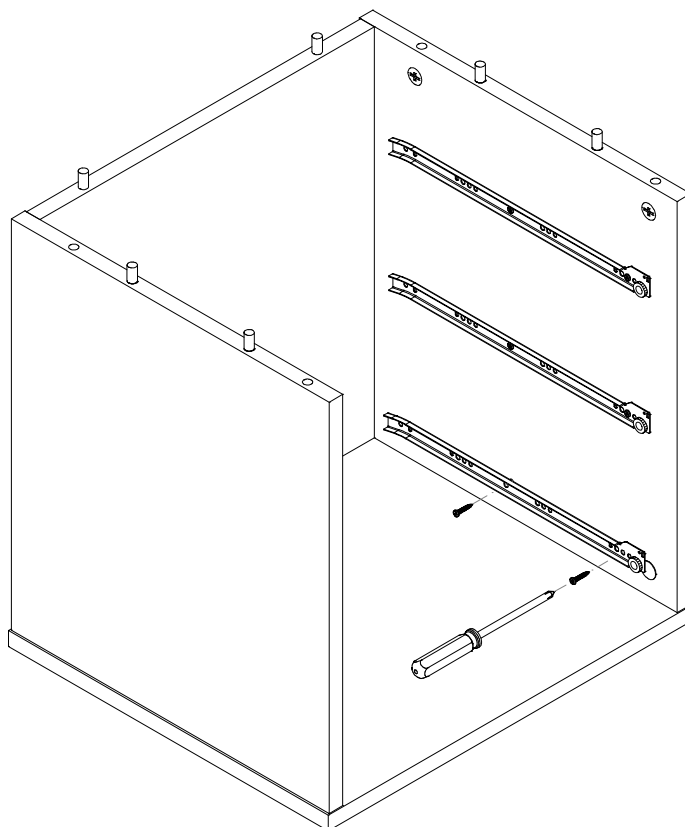

04

Partes do módulo

Module parts

Partes del módulo

1 Tampo (1x)

Top (1x) / Tapa (1x)

Ferramentas necessárias

Required tools

Herramientas requeridas

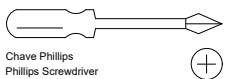

Chave Phillips
Phillips Screwdriver
Destornillador Phillips

Componentes do módulo

Module components

Componentes del módulo



D. Tapa Tambor (4x)

D. Minifix Housing Cover (4x)

D. Tapa Cajita Minifix (4x)

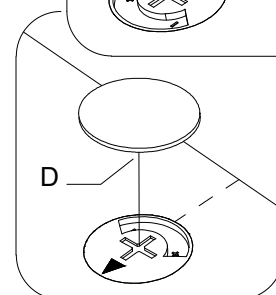
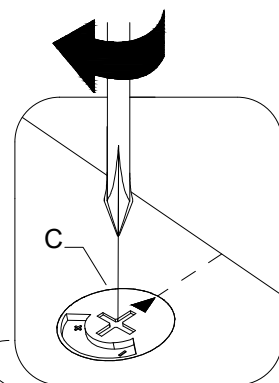
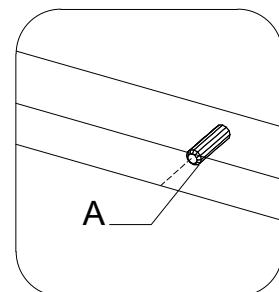
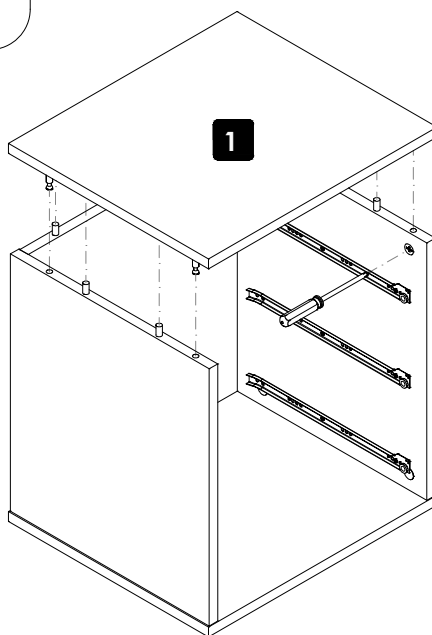
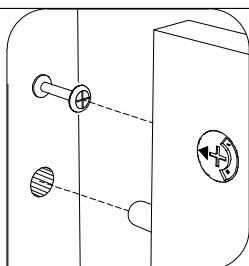

05

Partes do módulo

Module parts
Partes del módulo

8 Tampo (1x)
Top (1x) / Tapa (1x)

Ferramentas necessárias

Required tools
Herramientas requeridas

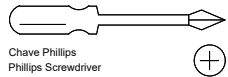

Chave Phillips
Phillips Screwdriver
Destornillador Phillips

Componentes do módulo

Module components
Componentes del módulo



D. Tampa Tambor (8x)
D. Minifix Housing Cover (8x)
D. Tapa Cajita Minifix (8x)

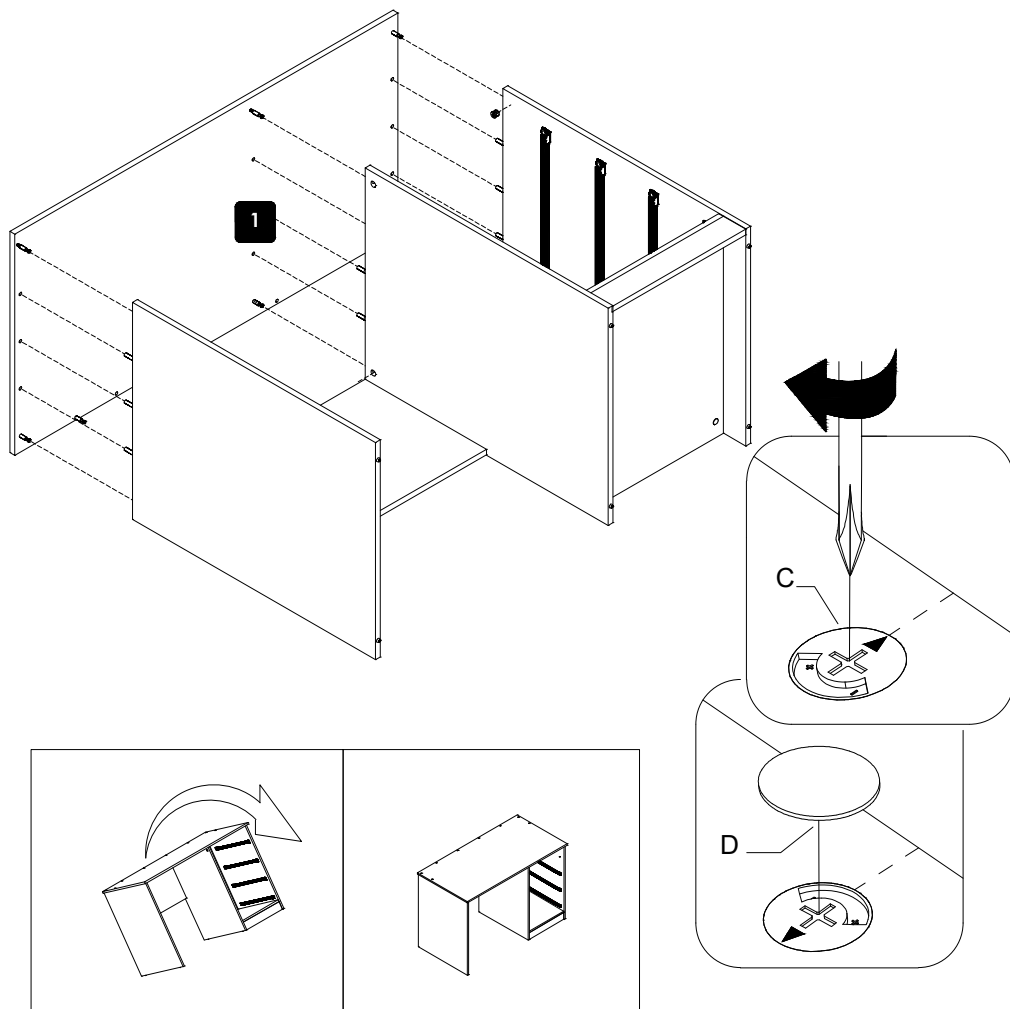

06

Partes do módulo

Module parts
Partes del módulo

8 Costa Usinada (1x)
Machine Back Strip (1x) /
Soporte Trasero Mecanizado (1x)

10 Lateral Superior (2x)
Side Support (2x) / Soporte Lateral (2x)

Ferramentas necessárias

Required tools
Herramientas requeridas

Componentes do módulo

Module components
Componentes del módulo

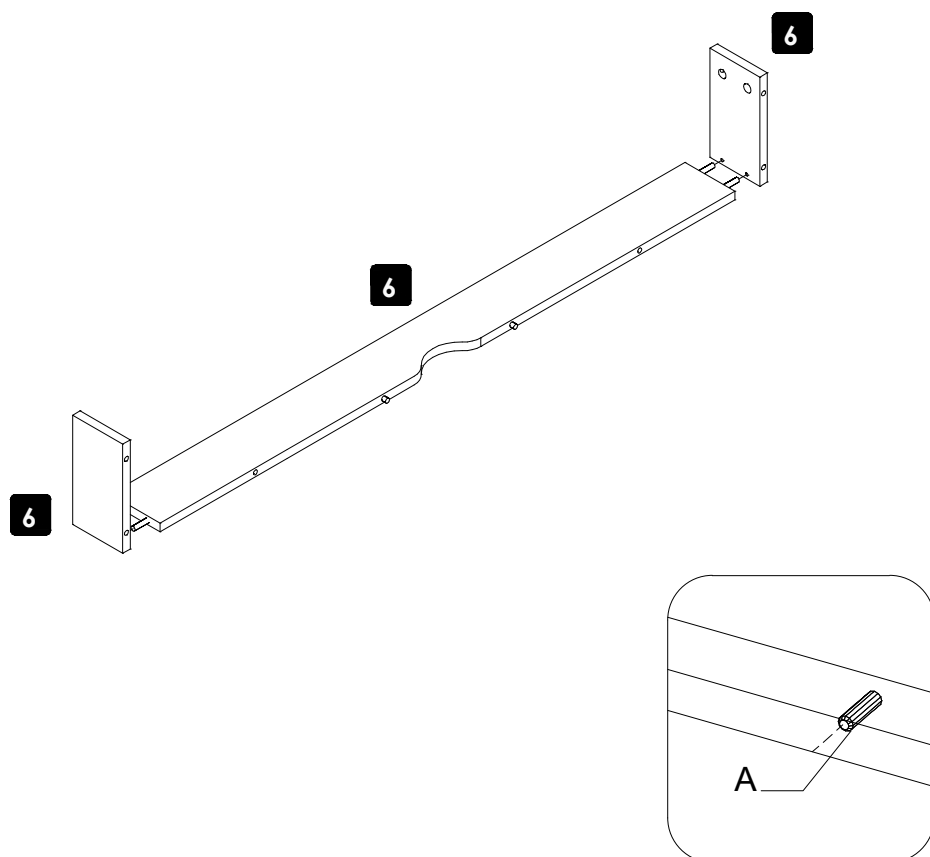

07

Partes do módulo

Module parts

Partes del módulo

- 6** Sobretampo (1x)
Upper Shelf (1x) / Repisa Superior (1x)
- 8** Costa Usinada (1x)
Machine Back Strip (1x) /
Soporte Trasero Mecanizado (1x)
- 10** Lateral Superior (2x)
Side Support (2x) / Soporte Lateral (2x)

Ferramentas necessárias

Required tools

Herramientas requeridas

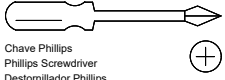

Chave Phillips
Phillips Screwdriver
Destornillador Phillips

Componentes do módulo

Module components

Componentes del módulo



- D. Tampa Tambor (4x)
- D. Minifix Housing Cover (4x)
- D. Tapa Cajita Minifix (4x)

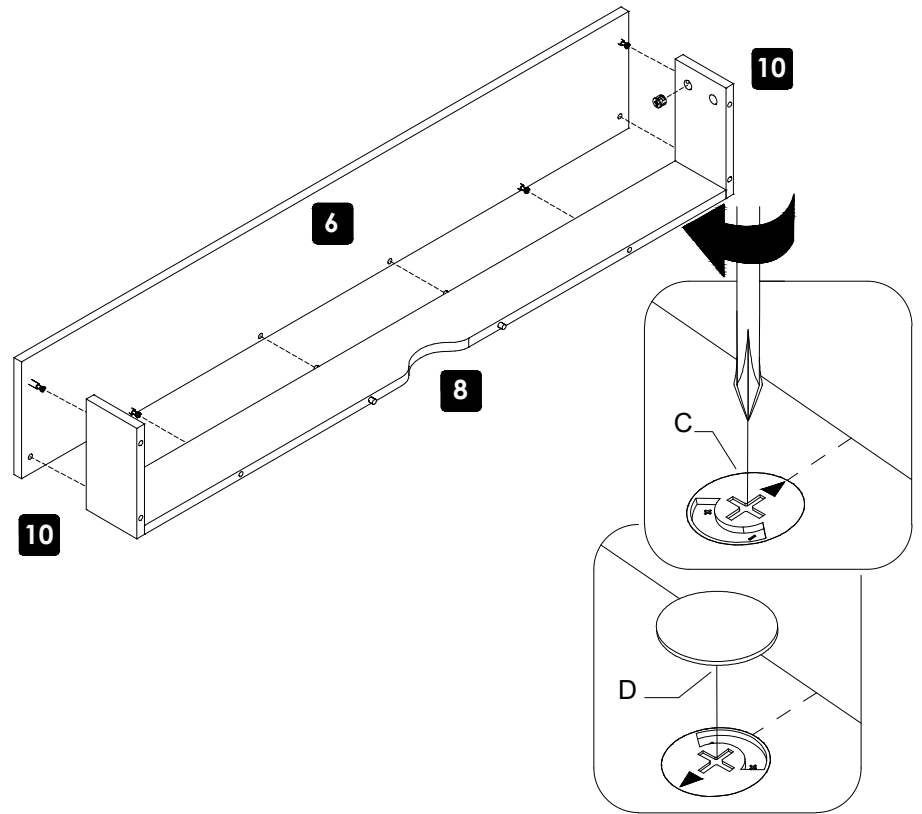

08

Partes do módulo

Module parts

Partes del módulo

- 1** Tampo (1x)
Top (1x) / Tapa (1x)
- 6** Sobretampo (1x)
Upper Shelf (1x) / Repisa Superior (1x)

Ferramentas necessárias

Required tools

Herramientas requeridas

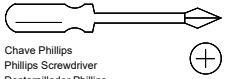

Chave Phillips
Phillips Screwdriver
Destornillador Phillips

Componentes do módulo

Module components

Componentes del módulo



- D. Tampa Tambor (4x)
- D. Minifix Housing Cover (4x)
- D. Tapa Cajita Minifix (4x)

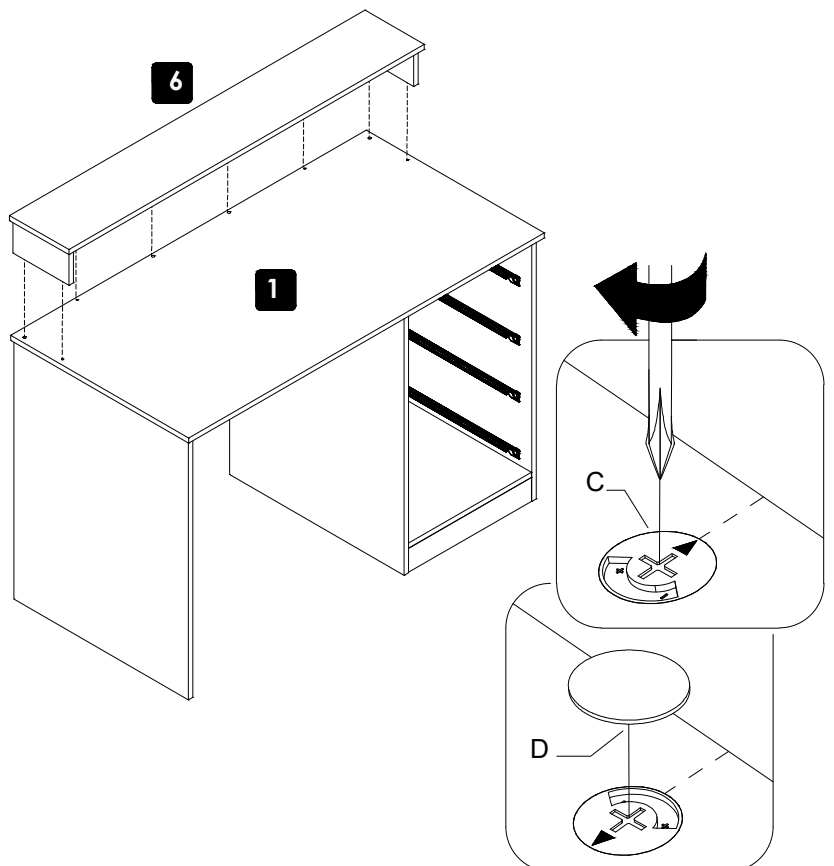

Pre-assembly of the drawer

Premontaje del cajón

Pré montagem da gaveta

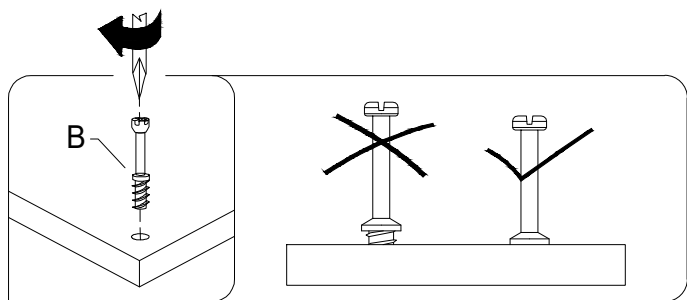
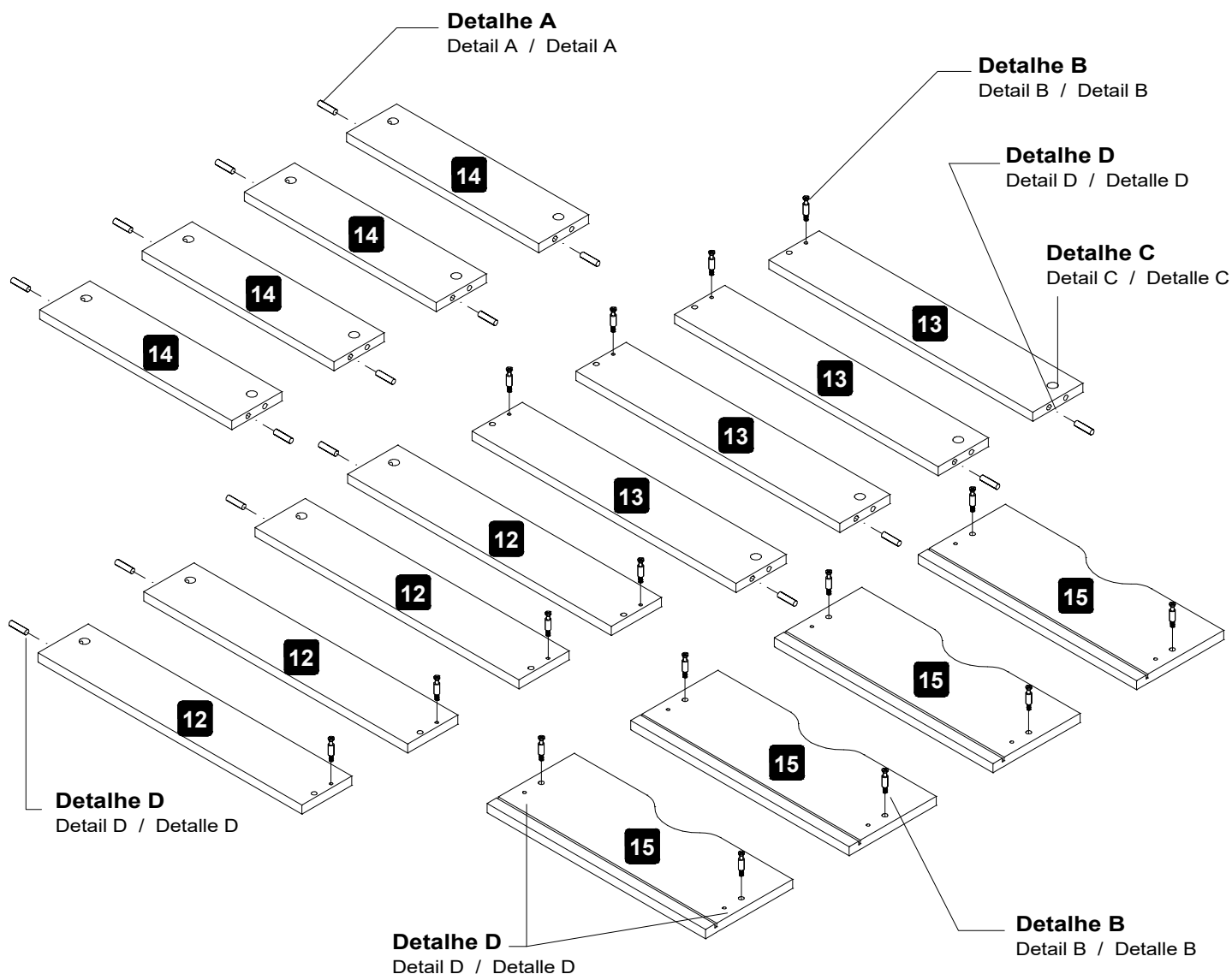

Detalhe B
Detail A / Detail A

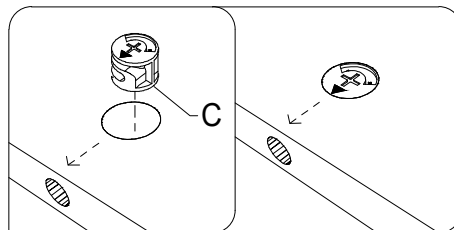

Detalhe C
Detail A / Detail A

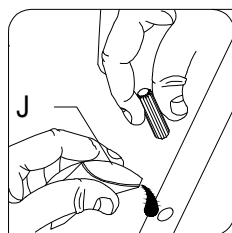

IMPORTANTE : utilizar cola nas cavilhas da frente da gaveta e aguardar 4 horas para secagem.

IMPORTANT : use glue on the dowel pins at the front of the drawer and wait 4 hours for drying.

IMPORTANTE : utilice pegamento en los tarugos del frente del cajón y espere 4 horas para que se sequen.

Detalhe D
Detail D / Detalle D

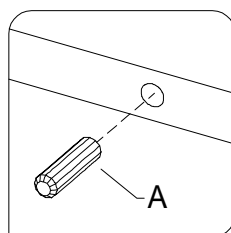

Detalhe A
Detail A / Detail A

09**Partes do módulo**

Module parts

Partes del módulo

12 Lateral esquerda gaveta (4x)
Left side drawer (4x) /
Lateral izquierda gaveta B (4x)**13** Lateral direita gaveta (4x)
Right side drawer (4x) /
Lateral derecho gaveta B (4x)**14** Fundo da gaveta (4x)
Drawer bottom (4x) / Fondo de cajón (4x)**Ferramentas necessárias**

Required tools

Herramientas requeridas

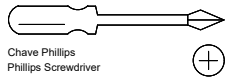
Chave Phillips
Phillips Screwdriver
Destornillador Phillips**Componentes do módulo**

Module components

Componentes del módulo

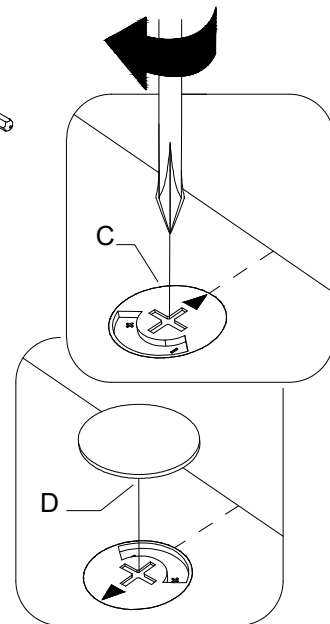
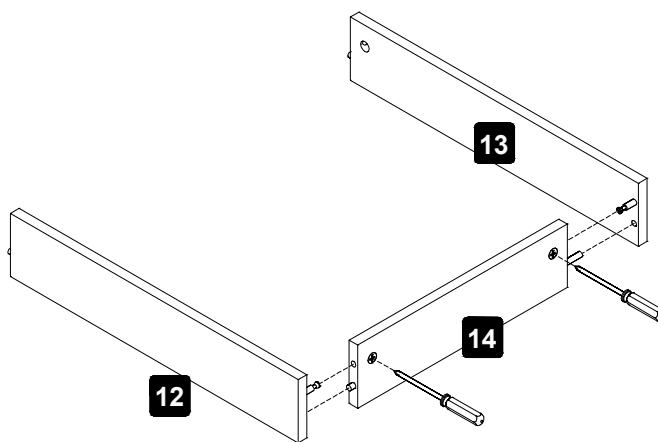
D. Tampa Tambor (8x)
D. Minifix Housing Cover (8x)
D. Tapa Cajita Minifix (8x)**10****Partes do módulo**

Module parts

Partes del módulo

15 Frente da gaveta (4x)
Drawer front (4x) / Frente de cajón (4x)**Ferramentas necessárias**

Required tools

Herramientas requeridas

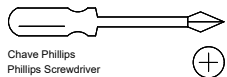
Chave Phillips
Phillips Screwdriver
Destornillador Phillips**Componentes do módulo**

Module components

Componentes del módulo

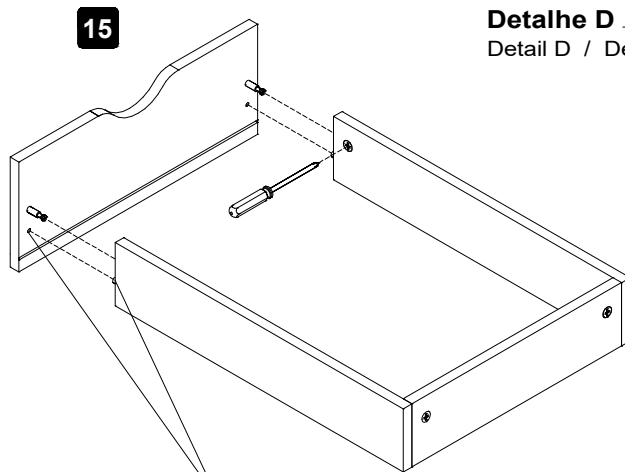
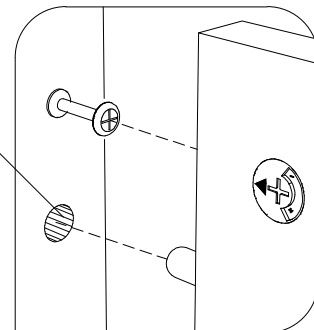
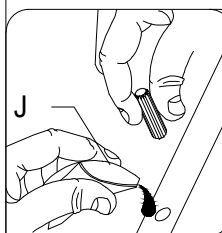
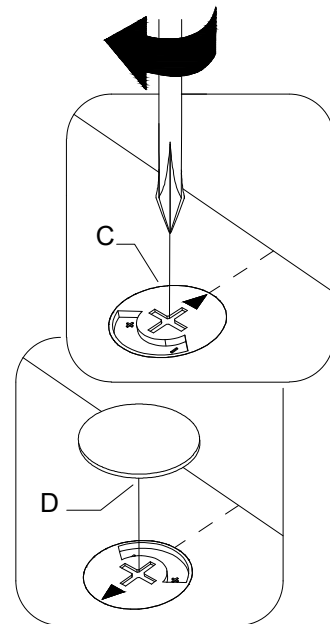
D. Tampa Tambor (8x)
D. Minifix Housing Cover (8x)
D. Tapa Cajita Minifix (8x)J. Cola (1x)
J. Glue (1x)
J. Pegamento (1x)**Detalhe D**
Detail D / Detalle D**Detalhe D**
Detail D / Detalle D**IMPORTANTE** : utilizar cola nas cavilhas da frente da gaveta e aguardar 4 horas para secagem.**IMPORTANT** : use glue on the dowel pins at the front of the drawer and wait 4 hours for drying.**IMPORTANTE** : utilice pegamento en los tarugos del frente del cajón y espere 4 horas para que se sequen.**Detalhe D**
Detail D / Detalle D

11

Partes do módulo

Module parts

Partes del módulo

16 Base da gaveta (4x)
Drawer stand (4x) / Base de cajón (4x)

Ferramentas necessárias

Required tools

Herramientas requeridas

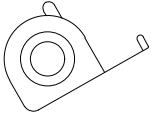

Fita Métrica
Measuring Tape
Cinta Métrica

Componentes do módulo

Module components

Componentes del módulo

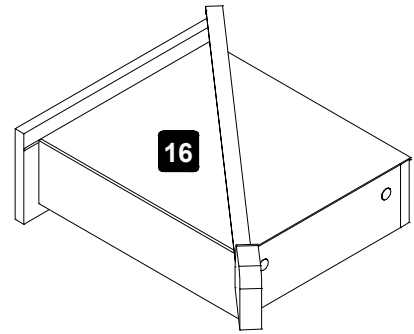
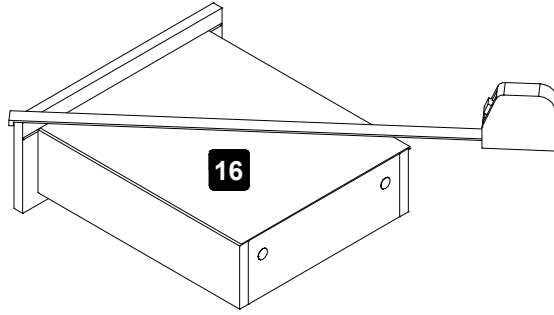

Ajuste a gaveta até o esquadro ter a mesma medida

Adjust the drawer until the square has the same

Ajuste el cajón hasta que la escuadra tenga la misma medida

12

Partes do módulo

Module parts

Partes del módulo

16 Base da gaveta (4x)
Drawer stand (4x) / Base de cajón (4x)

Ferramentas necessárias

Required tools

Herramientas requeridas

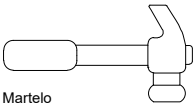

Martelo
Hammer
Martillo

Componentes do módulo

Module components

Componentes del módulo

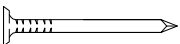

I. Prego (52x)
I. Nail (52x)
I. Clavo (52x)

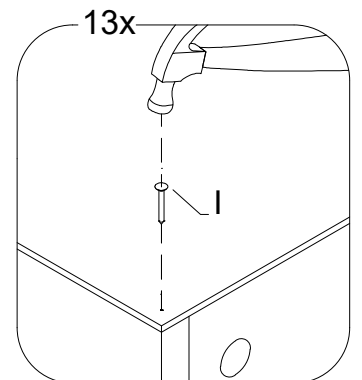
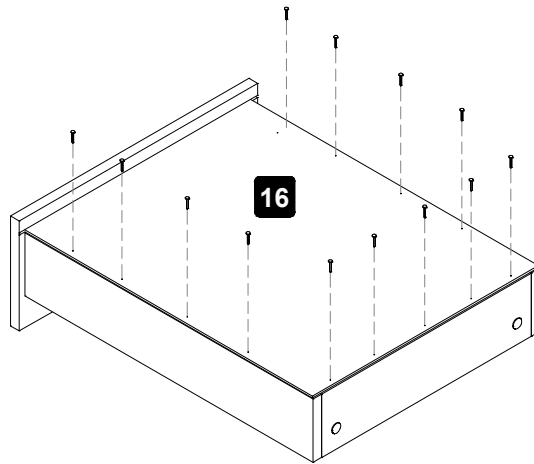

13

Partes do módulo

Module parts
Partes del módulo

16 Base da gaveta (4x)
Drawer stand (4x) / Base de cajón (4x)

Ferramentas necessárias

Required tools
Herramientas requeridas

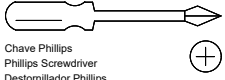

Chave Phillips
Phillips Screwdriver
Destornillador Phillips

Componentes do módulo

Module components
Componentes del módulo



K. Corrediça Gaveta (8x)
K. Slide Drawer (8x)
K. Corredera Cajón (8x)

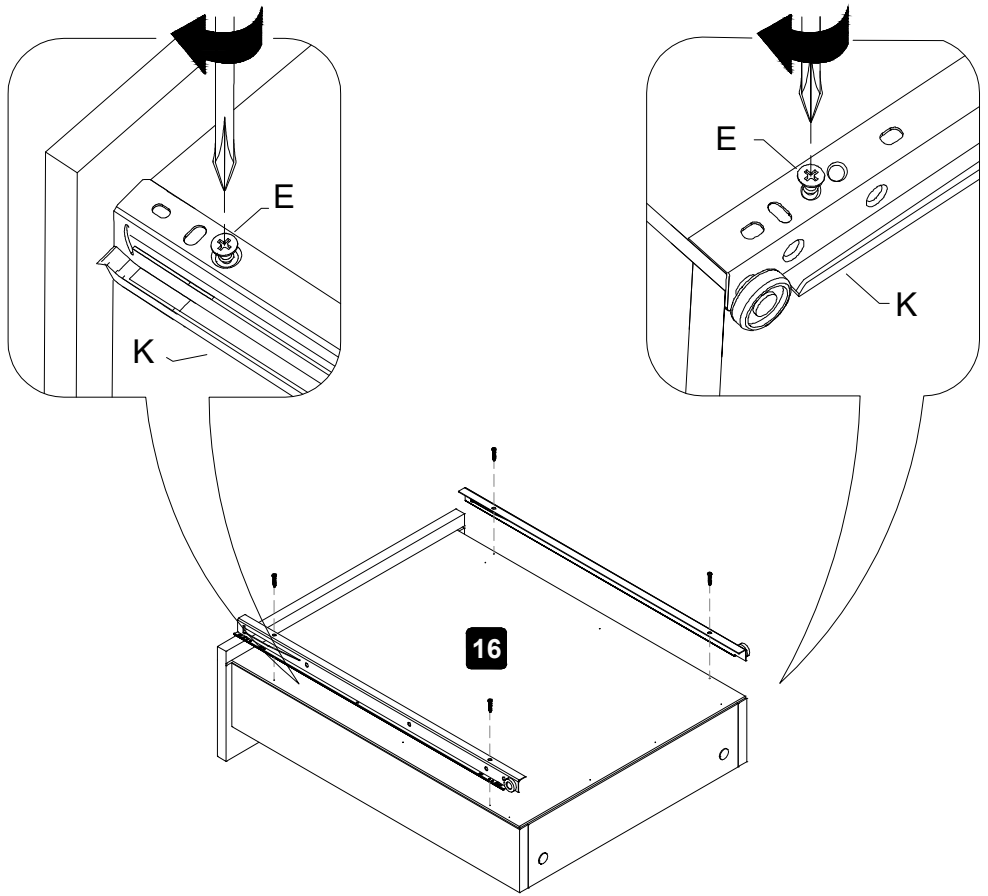

14

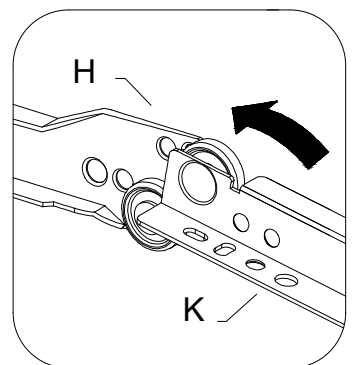
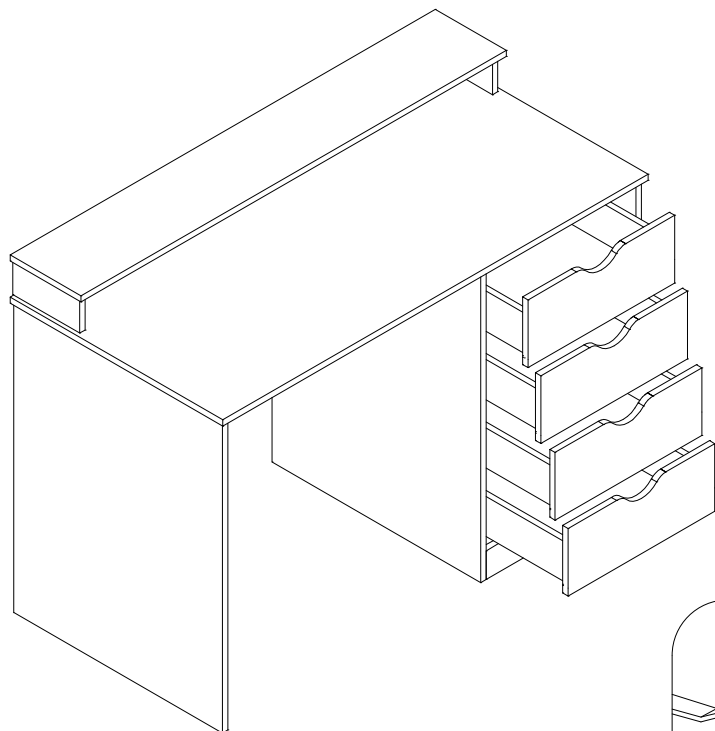

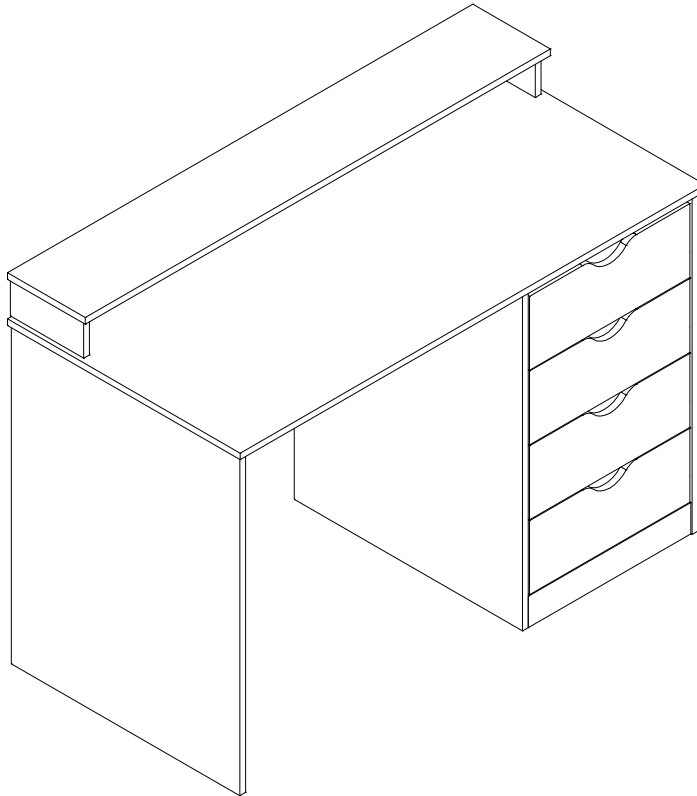

Capacidade de carga (distribuição uniforme)

Cargo capacity (uniform distribution)

Capacidad de carga (distribución uniforme)



tampo
top
tapa

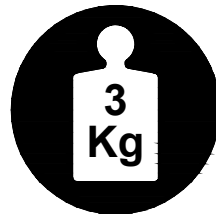

gaveta
drawer
cajón