

**KING BED**









(13 PCS LVL SLATS)

Read this instruction carefully. See hardware and furniture part list for guidance. Be sure all part is complete, before you assemble. Place all wooden furniture part on a clean and flat soft surface to prevent from being scratched. Follow the figure to start assembling.











**CAUTION:**

1. Do not FULLY-TIGHTEN the nut or bolt untill all nut or nut bolt is ready to assembled.
2. Do not OVER-TIGHTEN the nut or nut bolt to avoid causing damages to the thread.
3. Keep all hardware part out of reach of children.

**PART LIST**

NO	DESCRIPTION	QTY
1a	HEADBOARD (UPPER) 	1 PC
1b	HEADBOARD (BOTTOM) 	1 PC
2	FOOTBOARD 	1 PC
3	SIDE RAIL 	2 PCS
4	CENTER RAIL 	2 PCS
5	SUPPORT LEG 	6 PCS
6	SLAT 	13 PCS
7	BED LEG 	4 PCS

**HARDWARE LIST**

NO	DESCRIPTION	QTY
A	JCBB M8 X 35MM 	12PCS
B	JCBB M6 X 25MM 	8PCS
C	JCBC M6 X 40MM 	6PCS
D	SPRING WASHER 5/16" 	26PCS
E	FLAT WASHER 5/16" 	20PCS
F	FLAT WASHER 1/4" 	6PCS
G	CSK M4 X 20MM 	16PCS
H	CSK M4 X 30MM 	46PCS
I	ALLEN KEY M4 	1PC
J	ALLEN KEY M5 	1PC

**STEP 1**

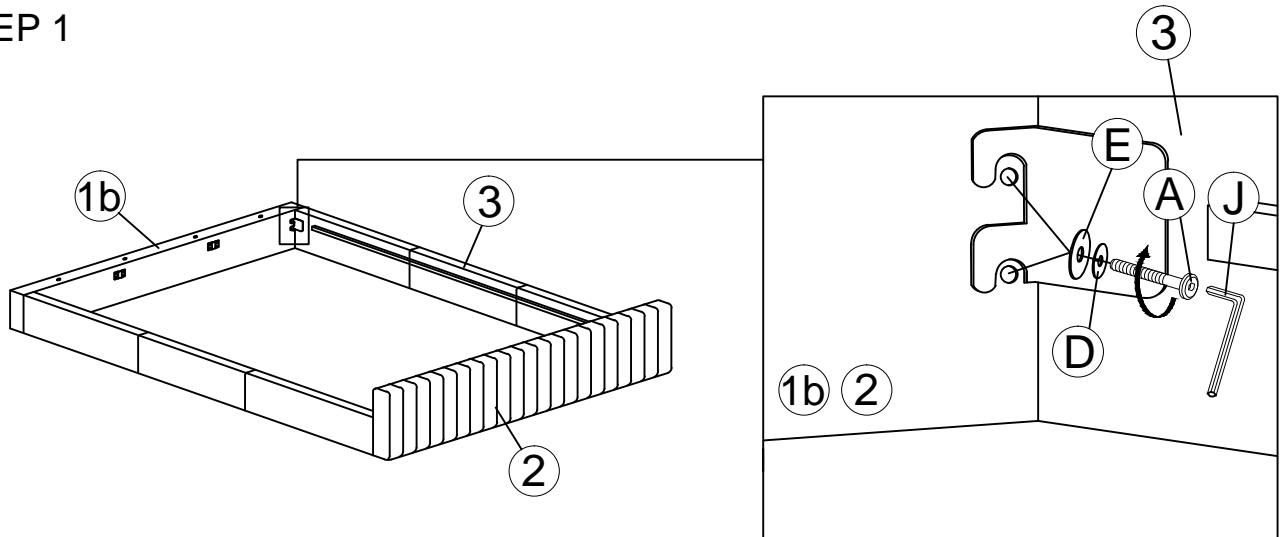

**STEP 2**

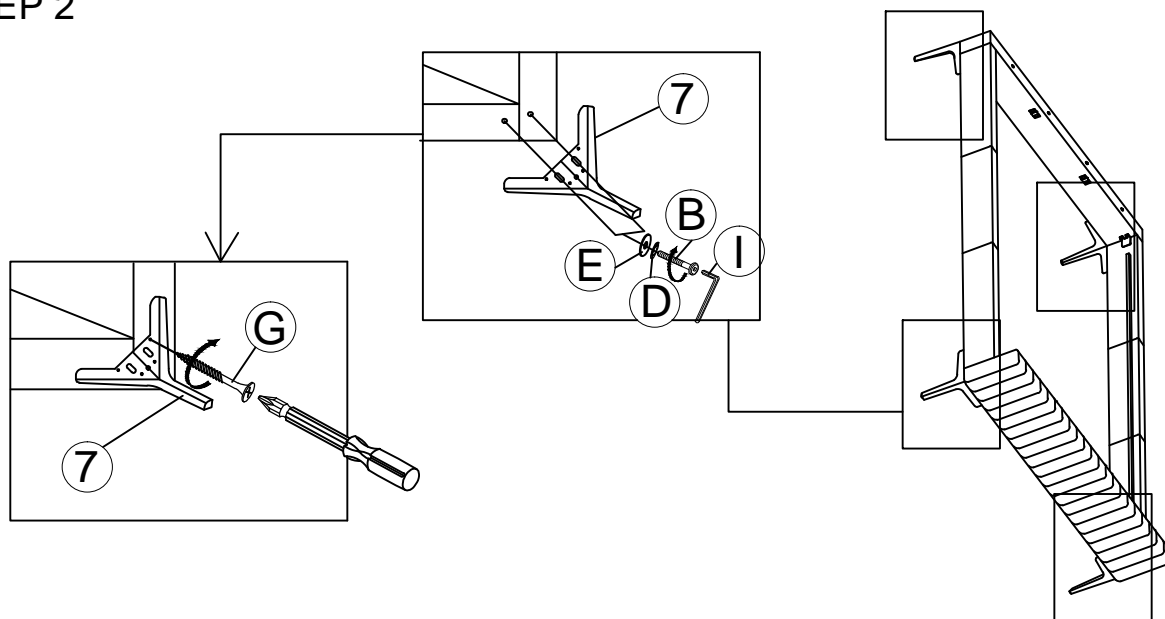

STEP 3

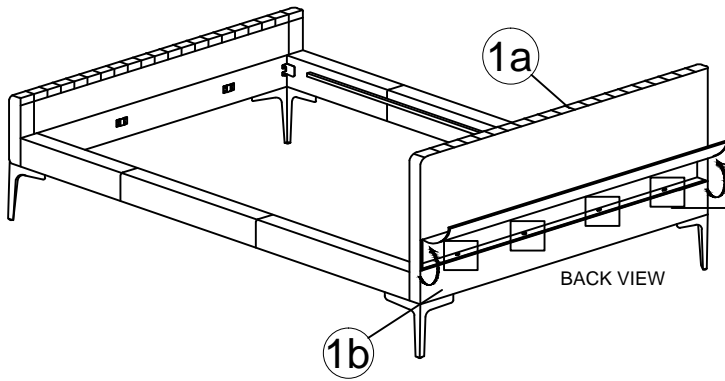

Open the Non -Woven Cover

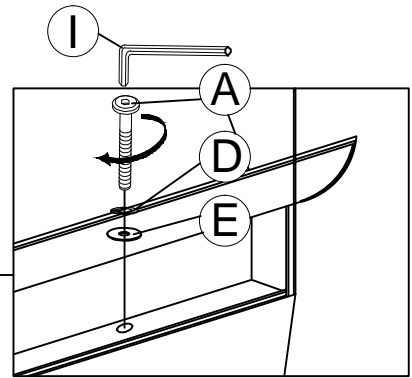

STEP 4

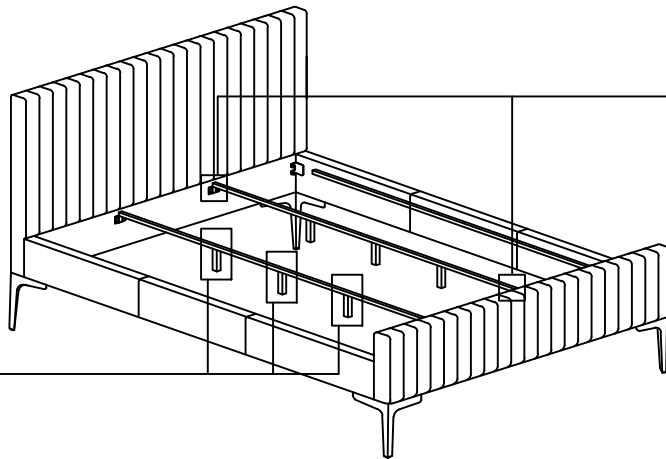
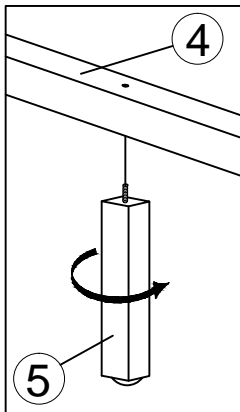

STEP 5

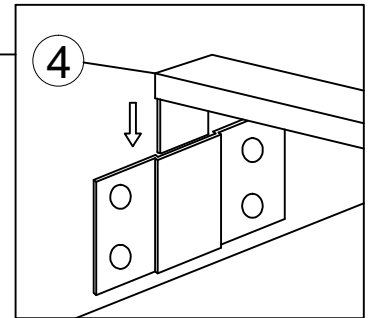

STEP 6

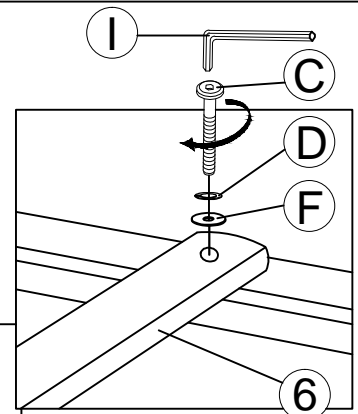
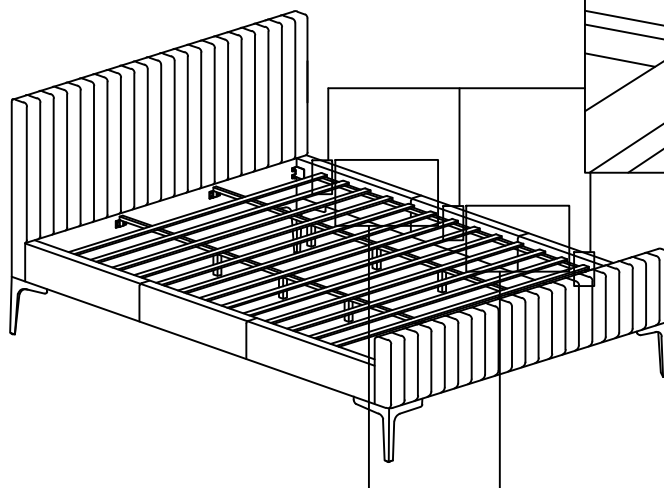
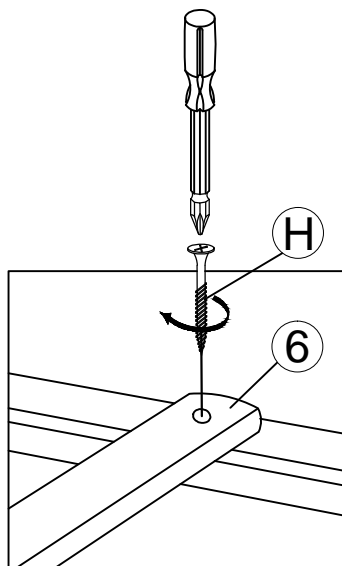

STEP 7

