

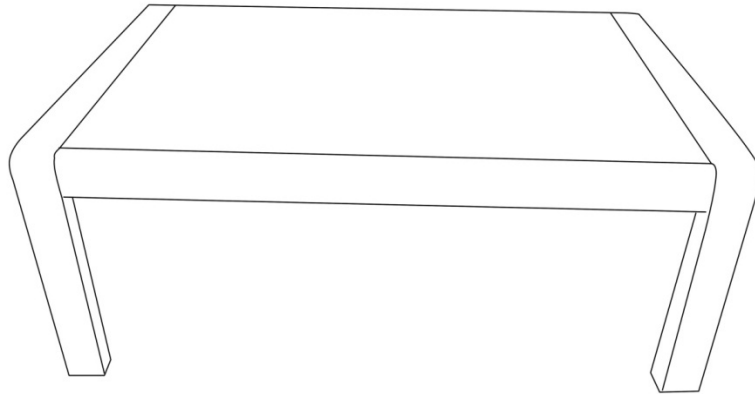

Assembly Instructions

Caution: You must read this before you proceed

Table

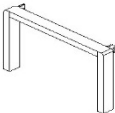
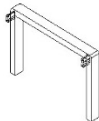
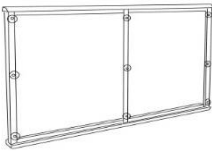

Parts List

Label	Picture	Description	QTY
A		Left Leg	1
B		Right Leg	1
C		Table Top Frame (with Suction Cups)	1
D		Glass Top	1

Hardware

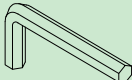
Label	Picture	Description	QTY
E		Bolt:M6*20MM	9
F		Allen Key	1

Assembly Preparation

Before Beginning Assembly:

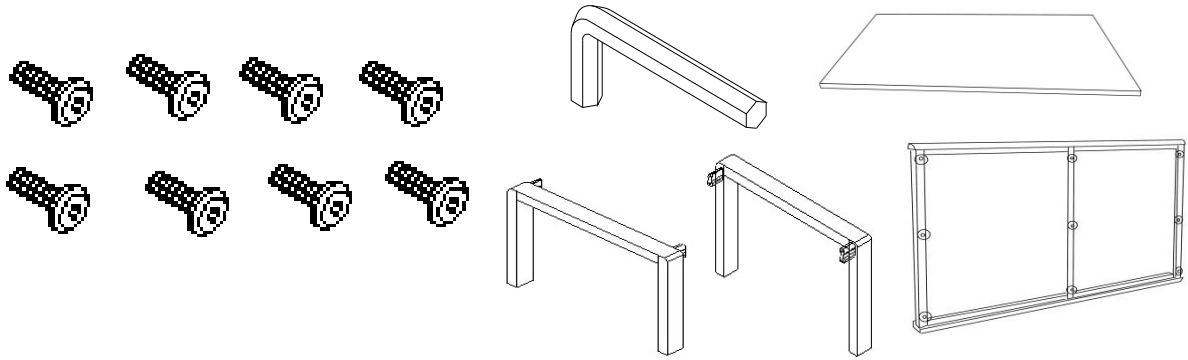

- Read instructions, cover to cover-



- Have 2 adults on hand for assembly-



- Do not assemble on flooring or carpet-



- Assemble on a clean non-marring surface (packing foam)-



- Save all packaging until finished-

Assembly Steps

Step 1

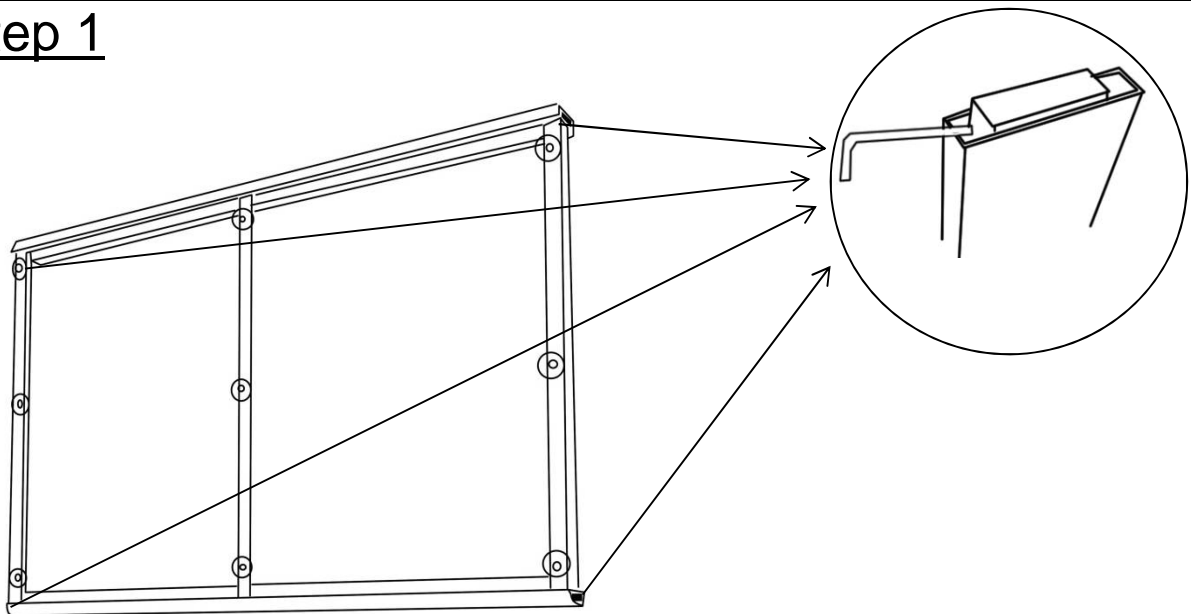

Take out the silders in the four ends of Table Top Frame(C) using Allen Key(F).

Step 2

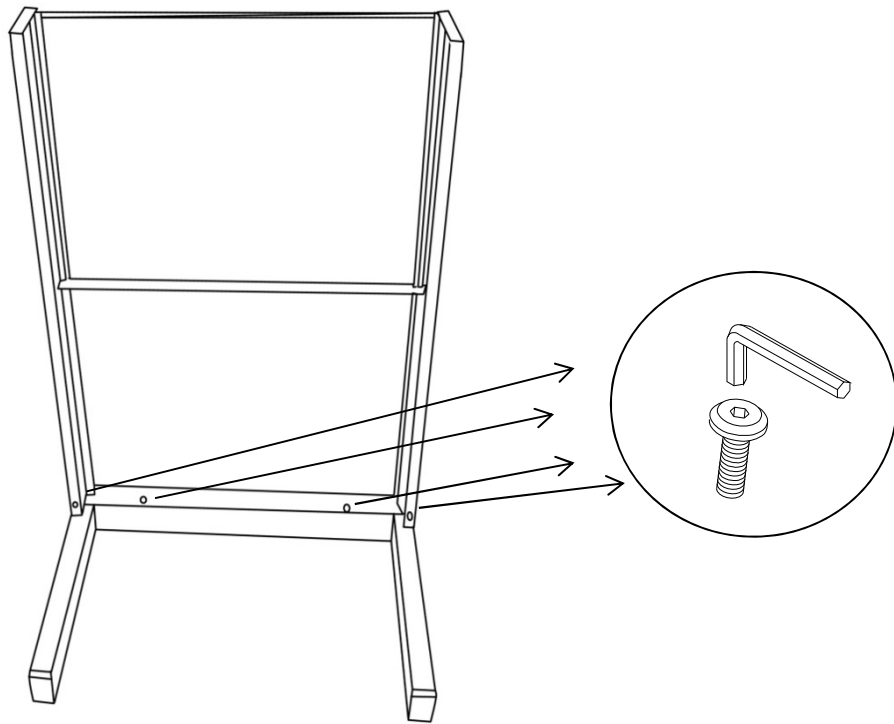

Open the carton and place all the parts on a clean, non-marring surface.
Attach the Table Top Frame(C) to the Left Leg(A) using Bolt(E) and Allen Key(F) as shown in the picture.

Loosely tighten the Bolts.

Caution: The Table and its Parts are Heavy. Two adults are required for lifting and moving them.

Step 3

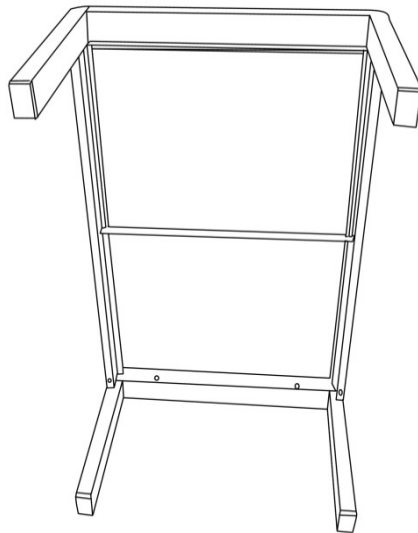

Attach the Table Top Frame(C) to the Right Leg(A) using Bolt(E) and Allen Key(F) as shown in the picture.

Loosely tighten the Bolts.

Caution: The Table and its Parts are Heavy. Two adults are required for lifting and moving them.

Step 4

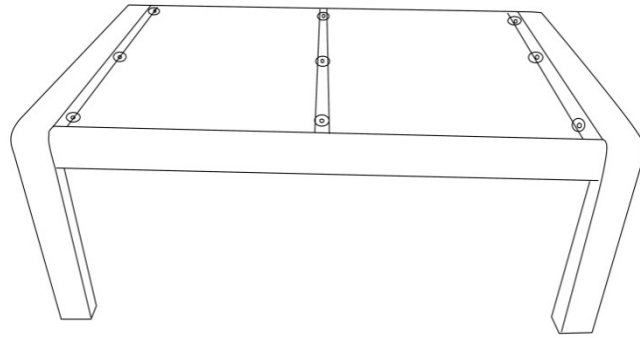

Stand up the table, check stability and then tighten the bolts.

Note DO NOT fully tighten a BOLT in one go and then move on to the next. Rather, In a sequential manner, gradually tighten each Bolt until all bolts are evenly secured. This methodology will ensure maximum evenness once all Bolts are fully tightened.

Step 5

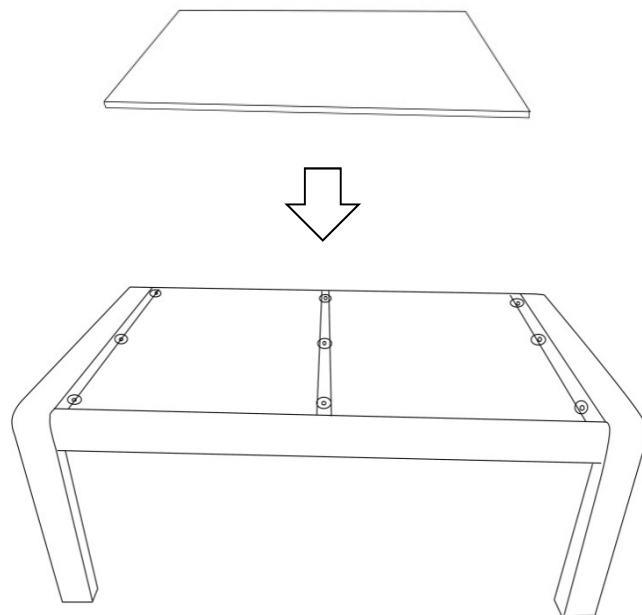

Place the Glass Top(D) on the assembled Table Frame.

Caution: The Table and its Parts are Heavy. Two adults are required for lifting and moving them.

Step 6

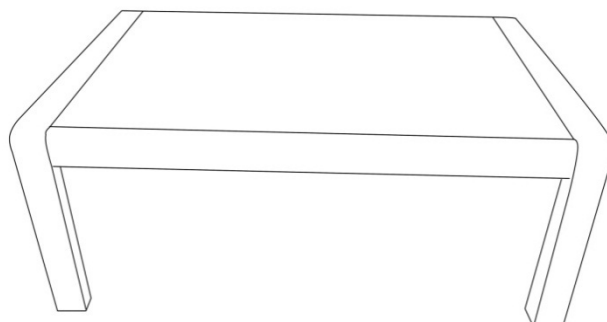

Your Table is ready for use.

Care & Maintenance



- Do not put hot items directly on furniture surface.



- Do not clean furniture with harsh cleansers or polish.



- To obtain the longest lifespan of your outdoor products, minimizing exposure to direct sunlight is recommended.



- Children should not climb or jump on the furniture.



- Do not write on furniture without a padded barrier to protect the surface.



- To obtain the longest lifespan of your outdoor products, avoid extended and lengthy exposure to rain, snow, and direct sunshine. Whenever possible cover the product and /or place under patio or awnings.



- Not for commercial use. For residential use only .



- Stains may be removed with mild soap solution and damp cloth.



- Dust and pick-up spills using a clean, non-colored, lint-free cloth .