

ASSEMBLY INSTRUCTION

COUNTER HEIGHT CHAIR

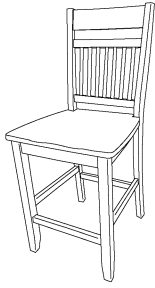

Thank you for purchasing this product. Please take time to read and follow the instructions below. Check that you have all parts and hardware before assembly. Parts apparently missing are often found in the packing materials. If you do not have all the parts listed, have your dealer contact us and they will be sent to you immediately.

It is recommended to install protective pads under all legs and supports to avoid damage or scratches when placing furniture on a wood floor or other hard surface, and to limit indentation and prevent discoloration if placing on carpet.

Hardware may loosen over time. Periodically check to make sure all connections are tight. Re-tighten if necessary.

PARTS LISTS			
No.		Description	Q'ty
1		Back Rest	1 pc
2		Wooden Seat	1 pc
3		Box Seat	1 pc
4		Front Leg (L)	1 pc
5		Front Leg (R)	1 pc
6		Strecher (L)	1 pc
7		Strecher (R)	1 pc
8		Front Strecher	1 pc

HARDWARE LISTS				
No.	Description	Size	Sketch	Q'ty
A	JCBC Bolt	Ø1/4" x 70mm		4 pcs
B	JCBC Bolt	Ø1/4" x 60mm		4 pcs
C	JCBC Bolt	Ø1/4" x 40mm		2 pcs
D	Spring Washer	Ø5/16" x Ø13mm		10 pcs
E	Flat Washer	Ø5/16" x Ø19mm (2mm Thickness)		10 pcs
F	CSK Screw	Ø4 x 32mm		10 pcs
G	Allen Key	M4 x 100mm		1 pc

* HARDWARE SET ARE PACKED FOR ASSEMBLY

* SCREWDRIVER (NOT PROVIDED)

STEP 1

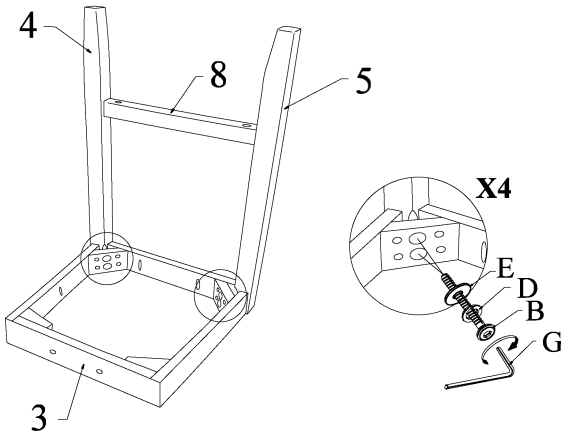

Do not tighten bolts until completely assembled.

STEP 2

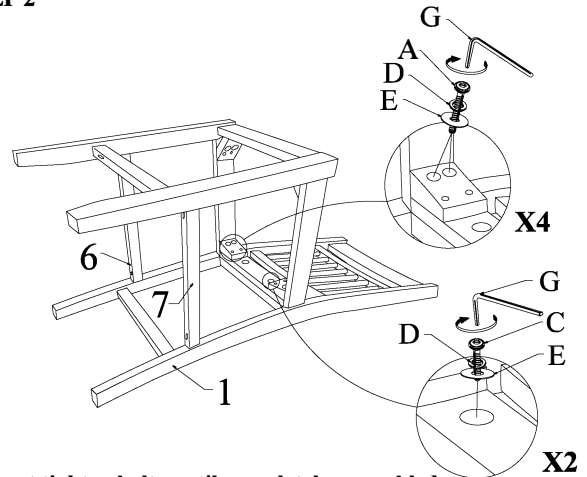

Do not tighten bolts until completely assembled.

STEP 3

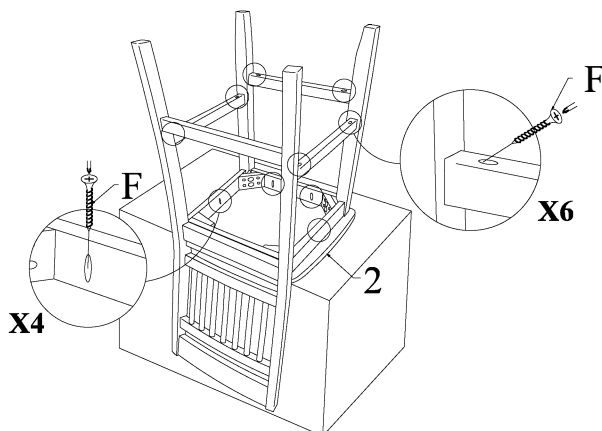

Please do fully tighten bolts in this step.

STEP 4

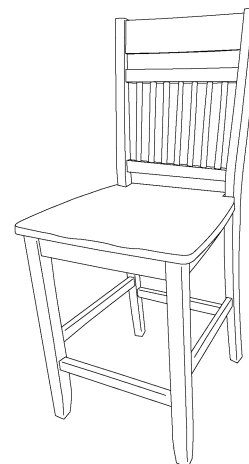

COMPLETED