

END TABLE ASSEMBLY INSTRUCTION

Thank you for purchasing this quality product. Be sure to check all packing material carefully for small parts which may have come loose inside the carton during shipment. Separate, identify and count all parts and hardware. Compare with the parts list to be sure all parts are present.

IMPORTANT : PLEASE READ INSTRUCTION BEFORE STARTING THE ASSEMBLY.

"DO NOT TIGHTEN SCREWS UNTIL COMPLETELY ASSEMBLED"

"DO NOT OVERTIGHT ANY HARDWARE"

WARNING : SMALL PARTS AND HARDWARE NOT FOR CHILDREN UNDER 3 YEARS. ADULT ASSEMBLY REQUIRED.

TABLE OF CONTENTS

HARDWARES LIST	PAGE 2
PARTS LIST	PAGE 3
PARTS' LOCATION	PAGE 4
ASSEMBLY STEPS	PAGE 5-6
ASSEMBLY COMPLETED	PAGE 6

ASSEMBLY TOOLS REQUIRED

1. Screwdriver (not provide)

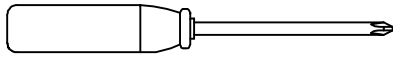

2. Hammer (not provide)

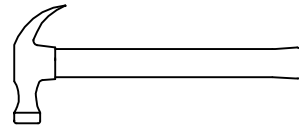



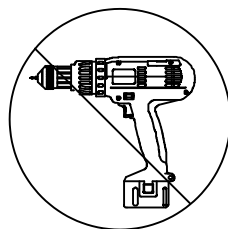

Skip the power drill this time.



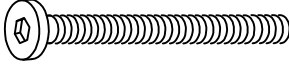

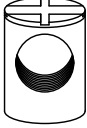
END TABLE ASSEMBLY INSTRUCTION

HARDWARES LIST

ITEM	DESCRIPTION	DRAWING	QTY
A	JCBC SCREW M6 x 30MM		8 PCS
B	JCBC SCREW M6 x 70MM		24 PCS
C	SPRING WASHER M6 x 12MM		32 PCS
D	FLAT WASHER M6.5 x 16MM		24 PCS
E	BARREL NUT M6 X 12MM		8 PCS
F	WOOD DOWEL M8 X 30MM		8 PCS
G	M4 ALLEN KEY (100MM)		1 PC

END TABLE ASSEMBLY INSTRUCTION

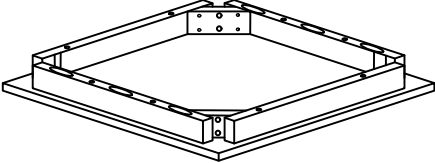
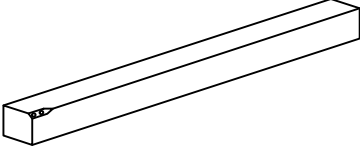
PARTS LIST

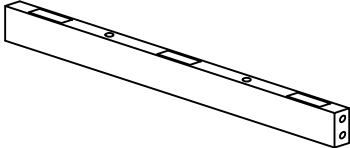
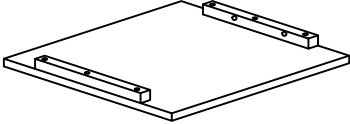
ITEM	DESCRIPTION	DRAWING	QTY
1	TOP PANEL		2 PCS
2	LEG WITH LABEL (L / R)		8 PCS
3	SUPPORT		12 PCS
4	LEG SUPPORT		4 PCS
5	BOTTOM PANEL		2 PCS

END TABLE ASSEMBLY INSTRUCTION

PARTS ' LOCATION

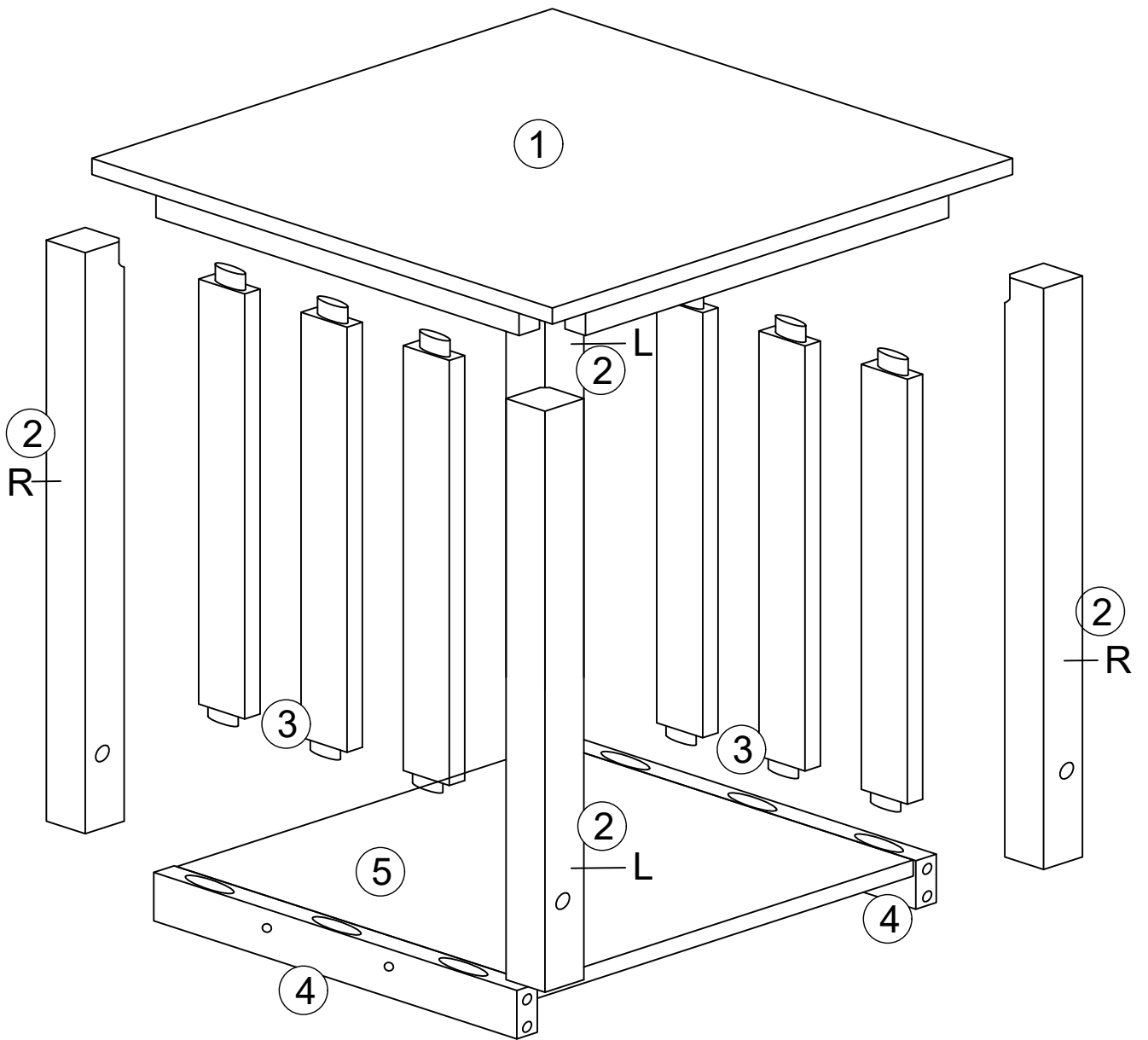

END TABLE ASSEMBLY INSTRUCTION

STEP 1

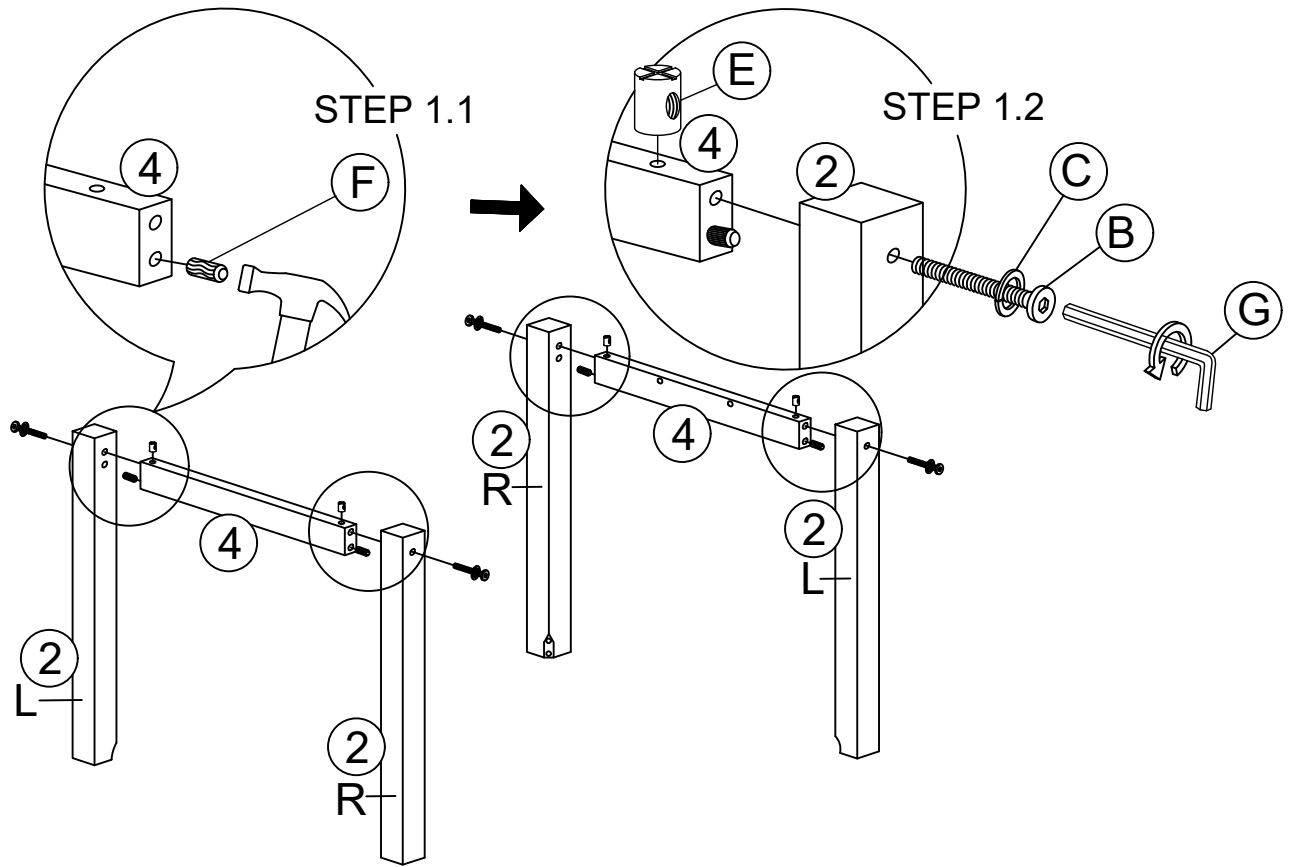

STEP 2

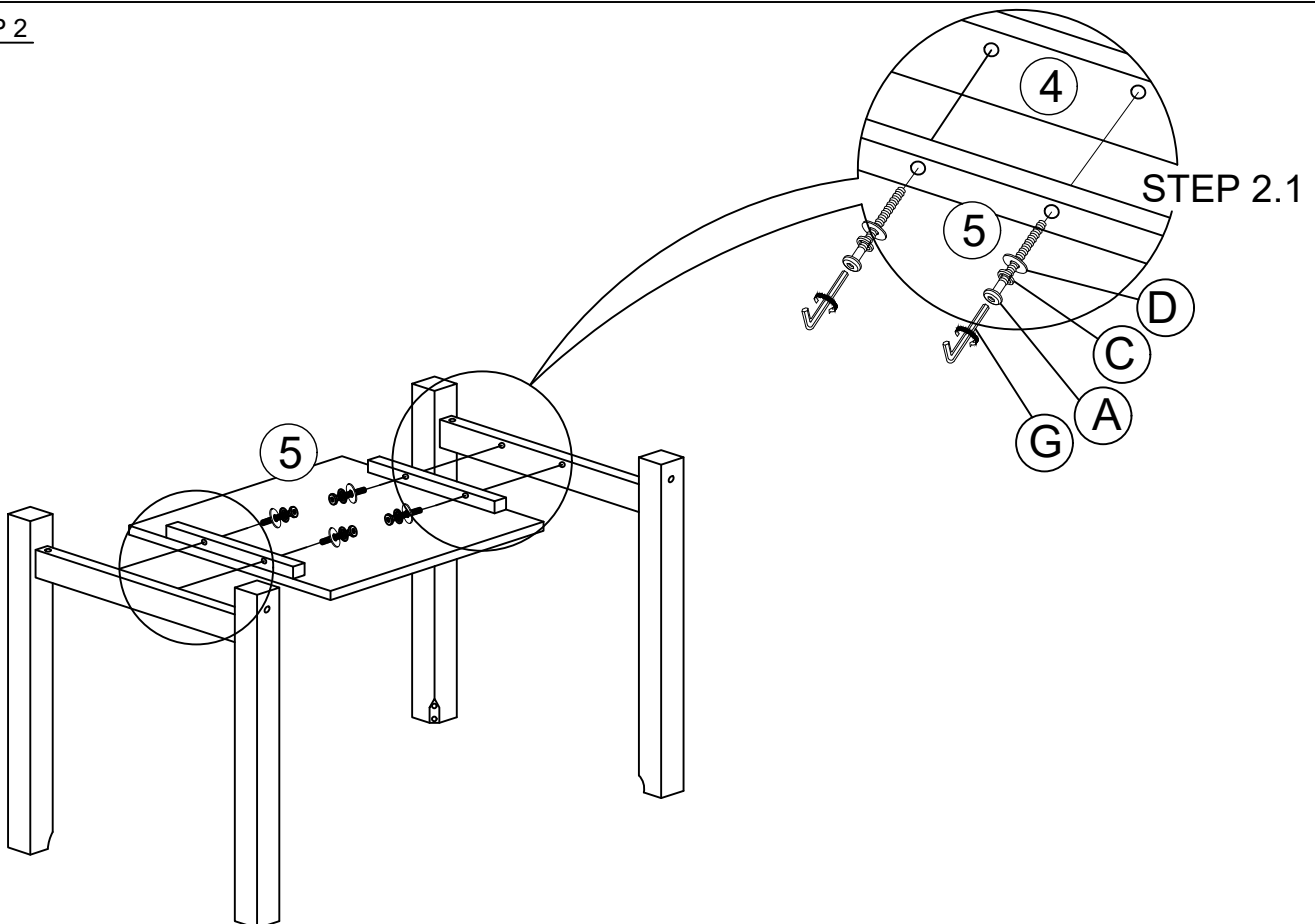

END TABLE ASSEMBLY INSTRUCTION

STEP 3

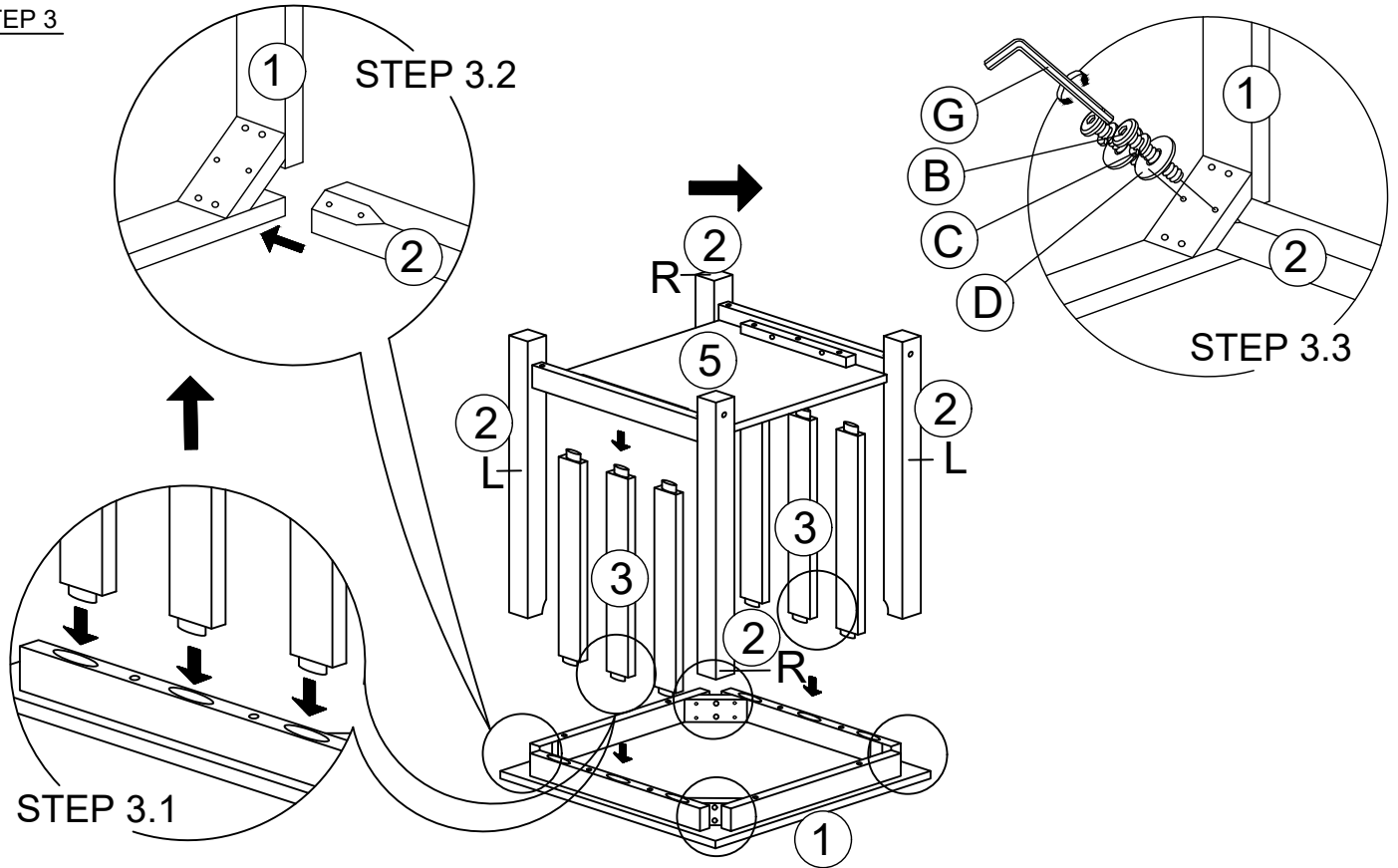

STEP 4

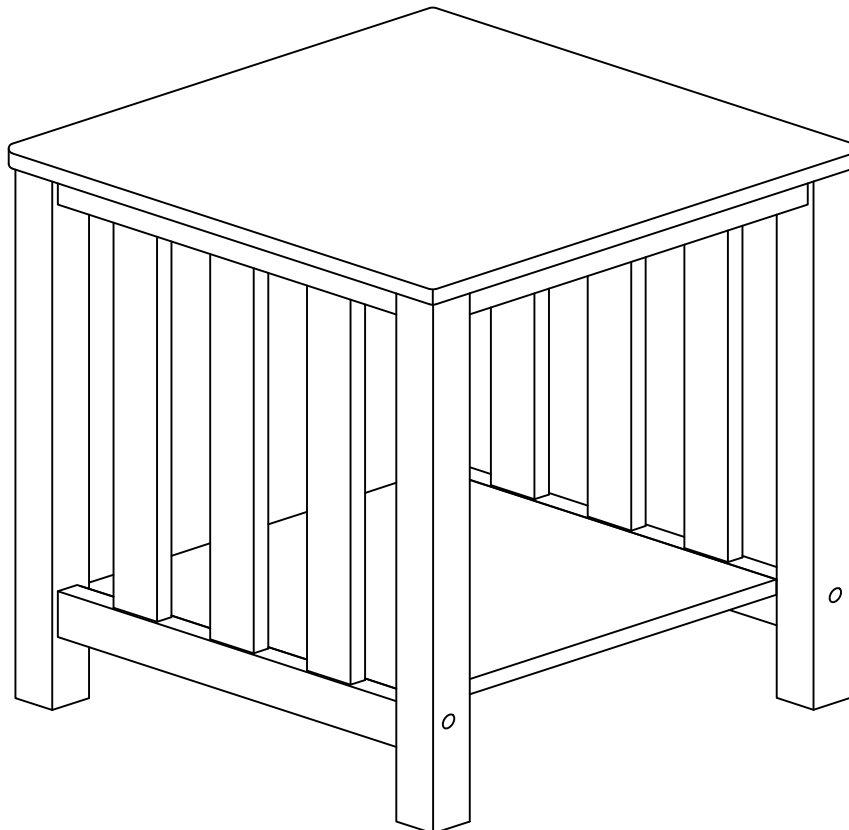

**ASSEMBLY
COMPLETED**