

# ASSEMBLY INSTRUCTION : MODE D'EMPLOI:INSTRUCCIONES DE ENSAMBLE

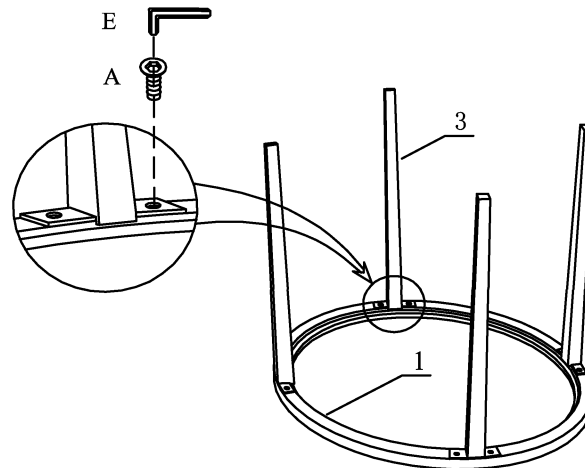

Step 1

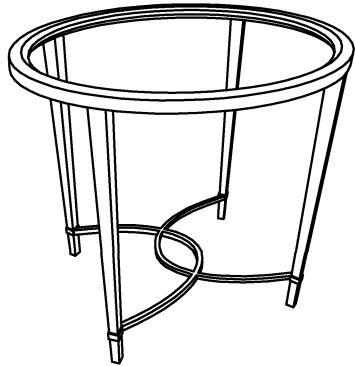
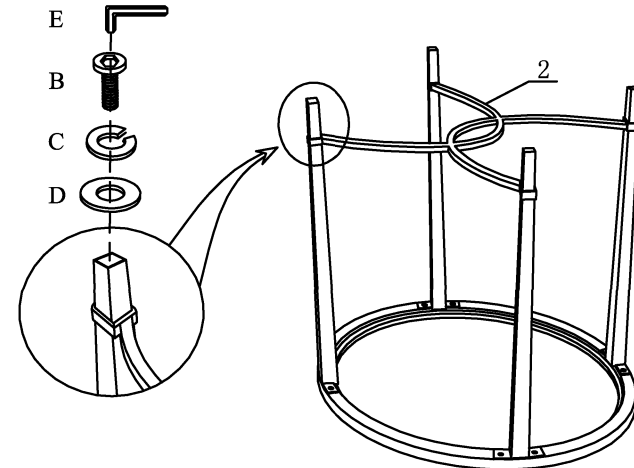

Step 2

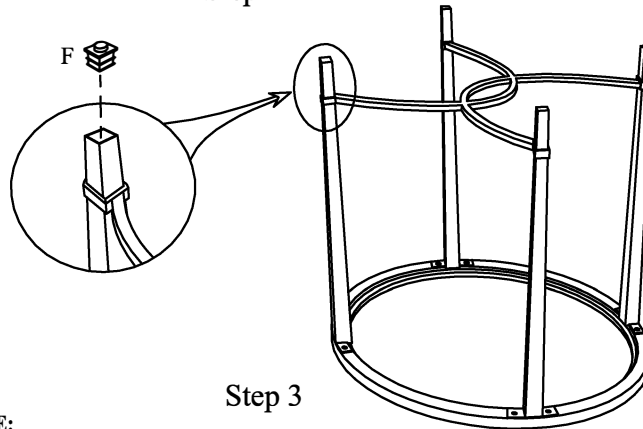

Step 3

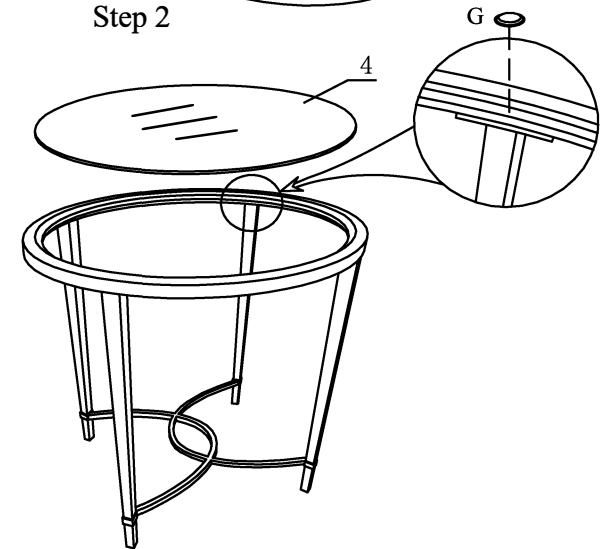

Step 4

COMPONENTS				
No.	PART	MAG. CODE	QTY.	DESCRIPTION
1		PT2114-07T	1 PC	Top Frame
2		PT2114-07B	1 PC	Bottom Frame w/ Small Foot
3		PT2114-07L	4 PCS	Metal Leg
4		PT2114-07G	1 PC	Glass Insert
ASSEMBLY HARDWARE				
A		1/4" *3/4"L	8 PCS	Bolt
B		1/4" *2-1/2"L	4 PCS	Bolt
C		Ø9*1.2mm	4 PCS	Lock Washer
D		Ø16*1mm	4 PCS	Flat Washer
E		1/4"	1 PC	Allen Wrench
F			4PCS	Plastic Mat
G			4PCS	Glass Bumper

**NOTE:**

ASSEMBLE UNIT ON A SOFT SURFACE.  
 ASSEMBLEZ L'UNITÉ SUR UNE SURFACE MOLLE.  
 ENSAMBLE LA UNIDAD EN UNA SUPERFICIE PLANA Y SUAVE.

DO NOT TIGHTEN BOLTS UNTIL THE UNIT IS COMPLETELY ASSEMBLED.  
 NE SERREZ PAS LES BOULONS JUSQU'À CE QUE L'UNITÉ SOIT COMPLÈTEMENT ASSEMBLÉE.  
 NO APRIETE LOS TORNILLOS HASTA QUE LA UNIDAD ESTE COMPLETAMENTE ENSAMBLADA.

# ASSEMBLY INSTRUCTION : MODE D'EMPLOI:INSTRUCCIONES DE ENSAMBLE

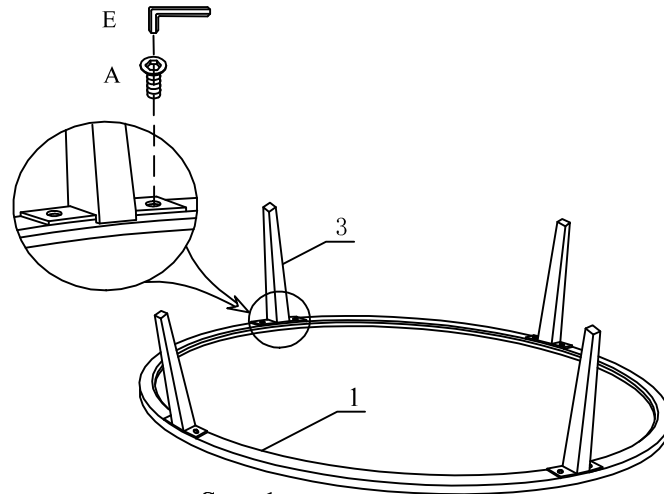
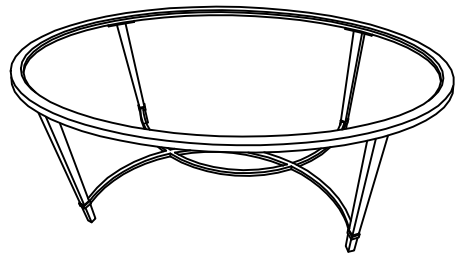

Step 1

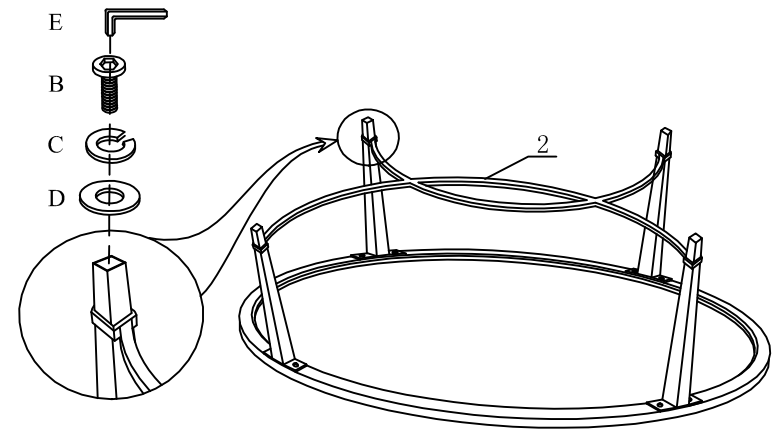

Step 2

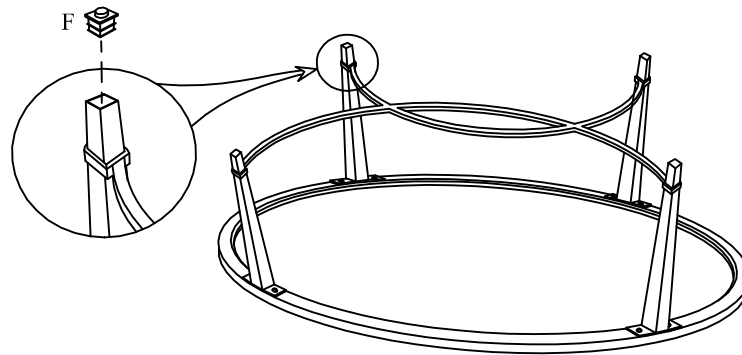

Step 3

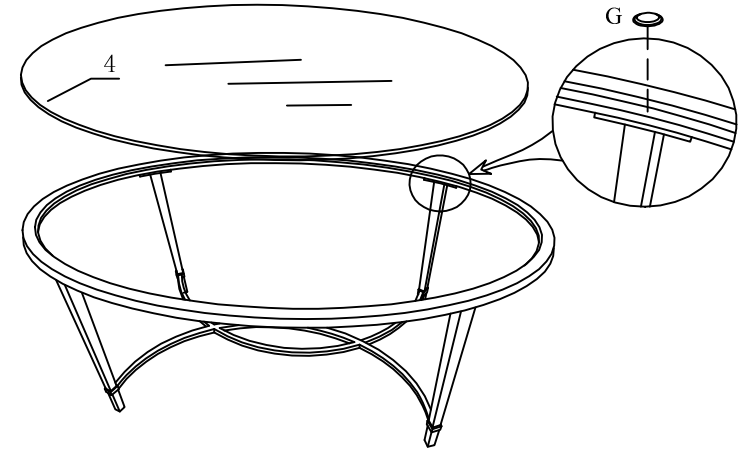

Step 4

COMPONENTS				
No.	PART	MAG. CODE	QTY.	DESCRIPTION
1		PT2114-47T	1 PC	Top Frame
2		PT2114-47B	1 PC	Bottom Frame w/ Small Foot
3		PT2114-47L	4 PC	Metal Leg
4		PT2114-47G	1 PC	Glass Insert
ASSEMBLY HARDWARE				
A		1/4" *3/4"L	8 PCS	Bolt
B		1/4" *2-1/2"L	4 PCS	Bolt
C		Ø9*1.2mm	4 PCS	Lock Washer
D		Ø16*1mm	4 PCS	Flat Washer
E		1/4"	1 PC	Allen Wrench
F			4PCS	Plastic Mat
G			4PCS	Glass Bumper

**NOTE:**

ASSEMBLE UNIT ON A SOFT SURFACE.  
 ASSEMBLEZ L'UNITÉ SUR UNE SURFACE MOLLE.  
 ENSAMBLE LA UNIDAD EN UNA SUPERFICIE PLANA Y SUAVE.

DO NOT TIGHTEN BOLTS UNTIL THE UNIT IS COMPLETELY ASSEMBLED.  
 NE SERREZ PAS LES BOULONS JUSQU'À CE QUE L'UNITÉ SOIT COMPLÈTEMENT ASSEMBLÉE.  
 NO APRIETE LOS TORNILLOS HASTA QUE LA UNIDAD ESTE COMPLETAMENTE ENSAMBLADA.

# ASSEMBLY INSTRUCTION : MODE D'EMPLOI:INSTRUCCIONES DE ENSAMBLE

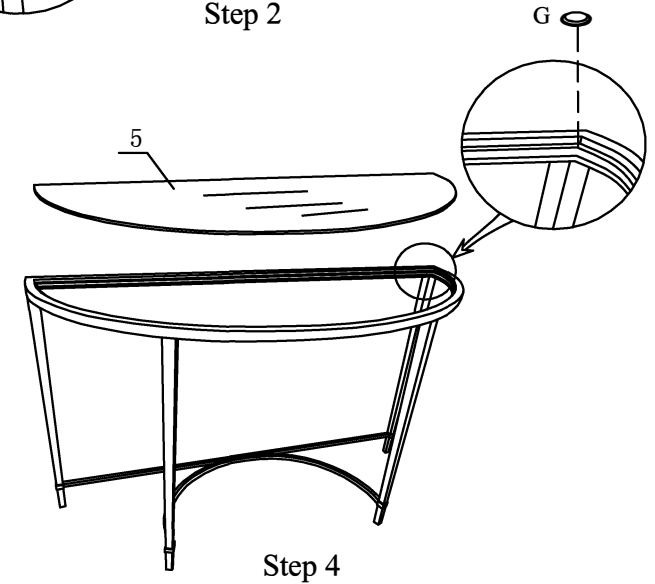
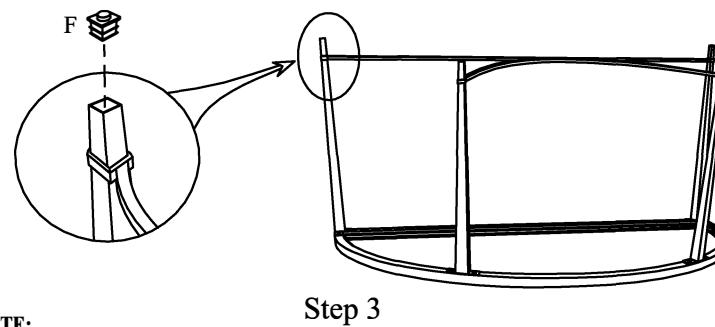
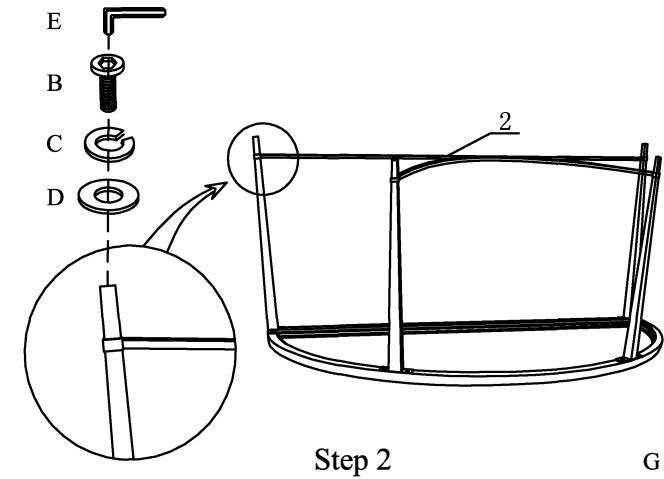
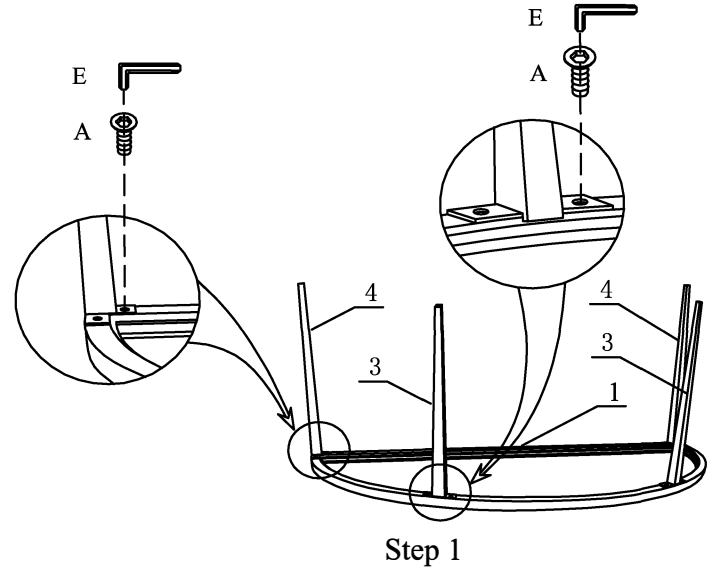

## COMPONENTS

No.	PART	MAG. CODE	QTY.	DESCRIPTION
1		PT2114-75T	1 PC	Top Frame
2		PT2114-75B	1 PC	Bottom Frame w/ Small Foot
3		PT2114-75L1	2 PCS	Metal Leg
4		PT2114-75L2	2 PCS	Metal Leg
5		PT2114-75G	1 PC	Glass Insert

## ASSEMBLY HARDWARE

A		1/4" *3/4"L	8 PCS	Bolt
B		1/4" *2-1/2"L	4 PCS	Bolt
C		Ø9*1.2mm	4 PCS	Lock Washer
D		Ø16*1mm	4 PCS	Flat Washer
E		1/4"	1 PC	Allen Wrench
F			4PCS	Plastic Mat
G			4PCS	Glass Bumper

### NOTE:

ASSEMBLE UNIT ON A SOFT SURFACE.  
 ASSEMBLEZ L'UNITÉ SUR UNE SURFACE MOLLE.  
 ENSAMBLE LA UNIDAD EN UNA SUPERFICIE PLANA Y SUAVE.

DO NOT TIGHTEN BOLTS UNTIL THE UNIT IS COMPLETELY ASSEMBLED.  
 NE SERREZ PAS LES BOULONS JUSQU'À CE QUE L'UNITÉ SOIT COMPLÈTEMENT ASSEMBLÉE.  
 NO APRIETE LOS TORNILLOS HASTA QUE LA UNIDAD ESTE COMPLETAMENTE ENSAMBLADA.