

Side Table

ID0150711WH

or

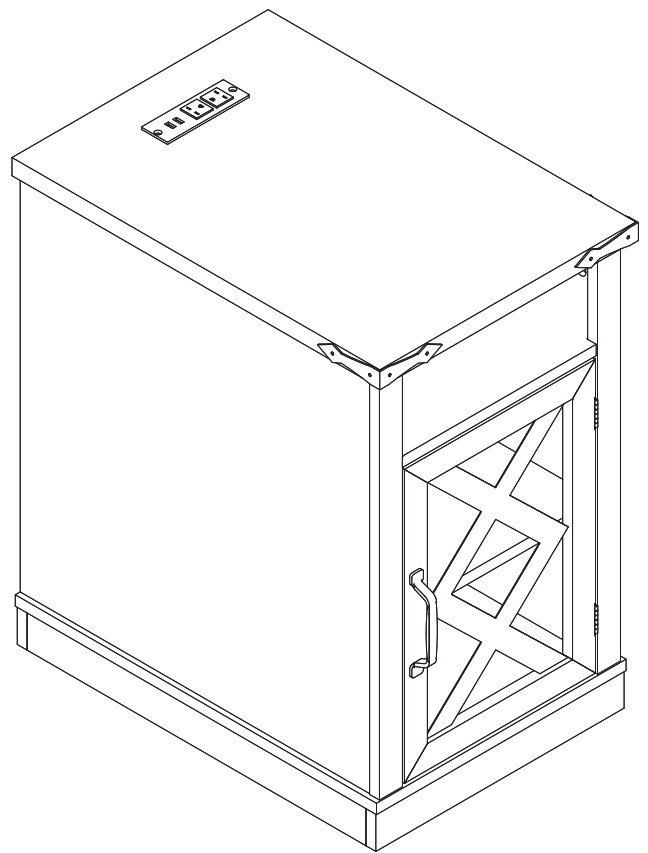
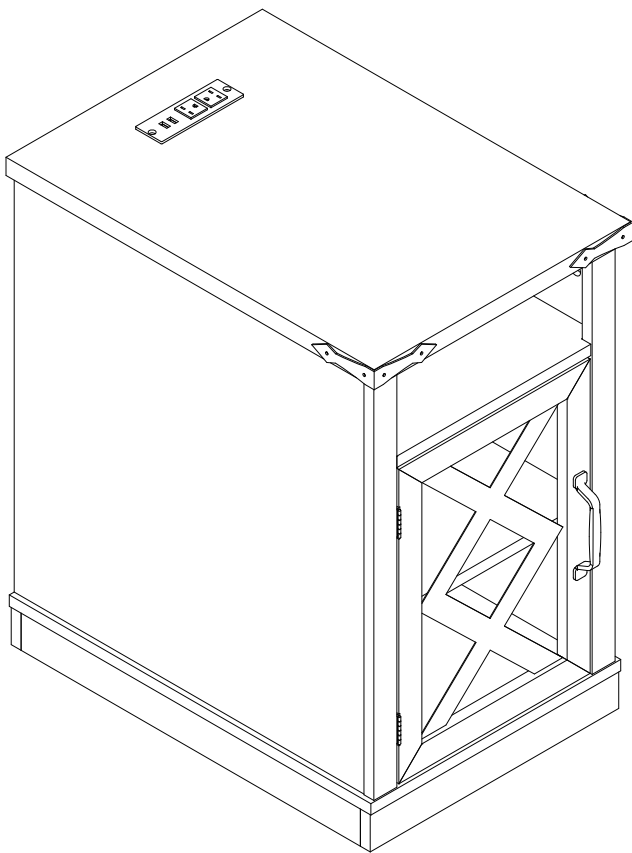

Important – Please read these instructions fully before starting assembly
Customer Service: contactus24service@gmail.com
Phone: (951) 213-4742

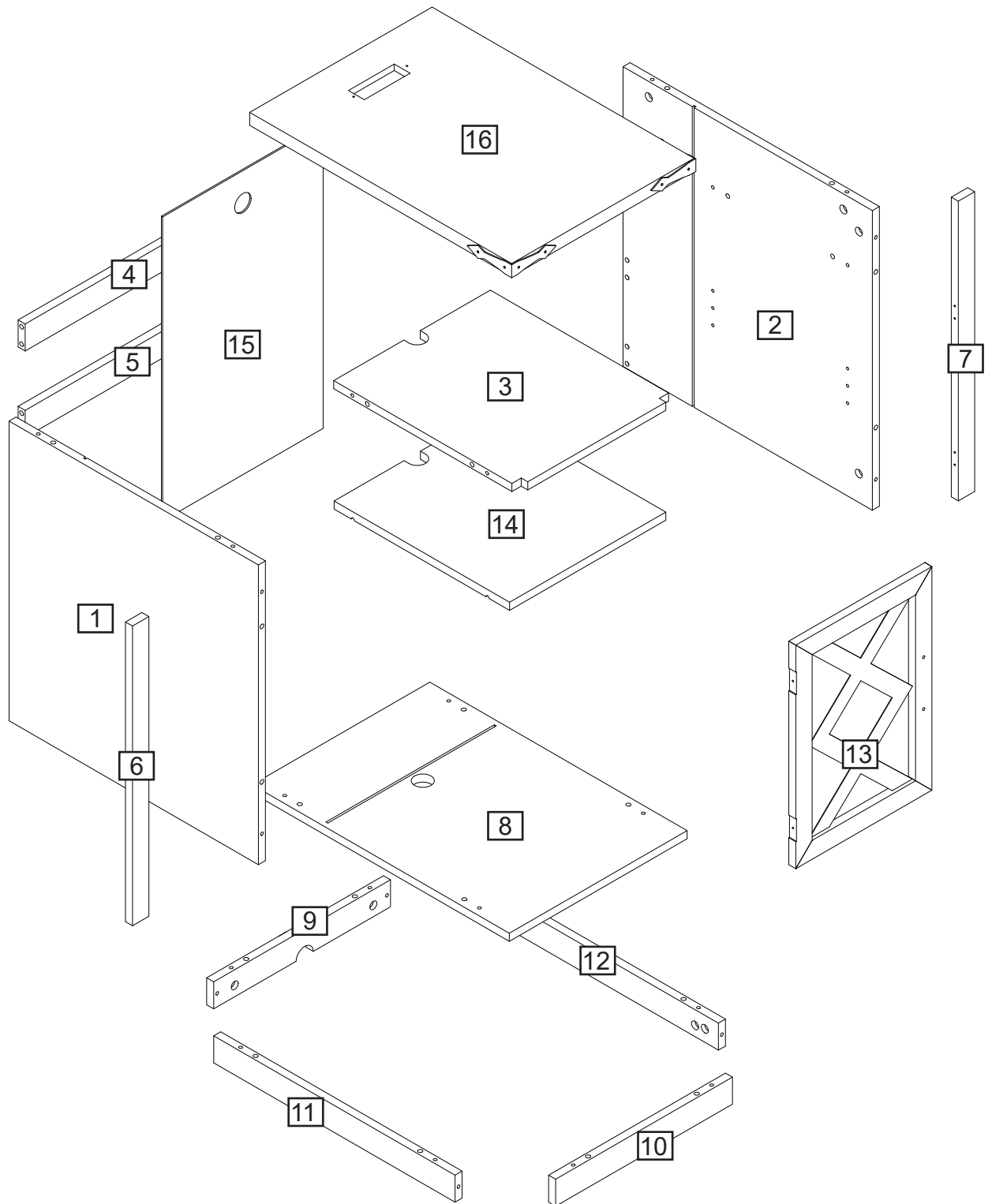

ASSEMBLY INSTRUCTIONS

Part List:

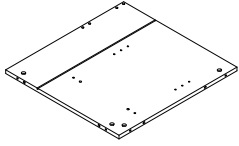
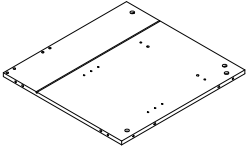
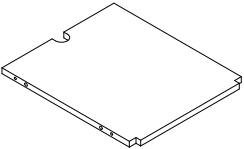
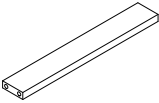
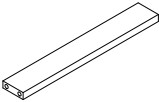
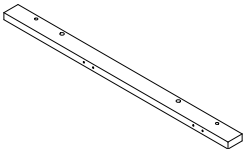
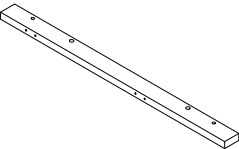
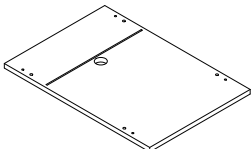



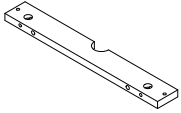
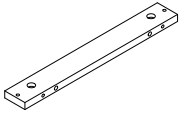
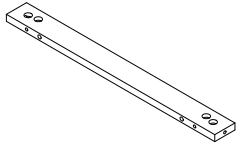
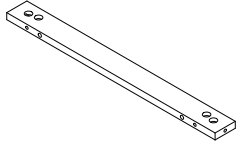
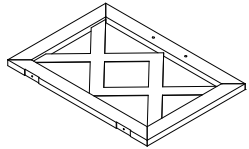
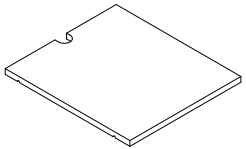
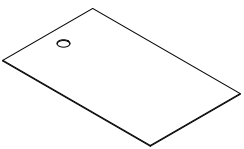
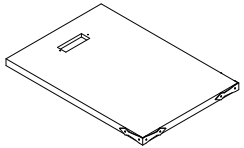







ITEM	DESCRIPTION	PART	QTY
1	Left side board		1
2	Right side board		1
3	Upper fixing board		1
4	Middle fixing board behind back board		1
5	Under fixing board behind back board		1
6	Front vertical bar of left		1
7	Front vertical bar of right		1
8	Bottom board		1

Part List:

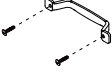
ITEM	DESCRIPTION	PART	QTY
9	Bottom back covering		1
10	Bottom front covering		1
11	Bottom left side covering		1
12	Bottom right side covering		1
13	Door		1
14	Shelf		1
15	Back board		1
16	Top board		1

ASSEMBLY INSTRUCTIONS

Hardware List:

ITEM	DESCRIPTION	PART	QTY
A	7*39mm Cam bolt		24
B	Cam lock		24
C	8*30mm Dowel		32
D	3.5*14mm Screw		15
E	5*40mm Screw		4
F	Foot nail		4
G	Handle		1
H	Door stopper		1
I	Shelf support pin		4
J	Hinge		2
K	Door stopper		1
L	Socket		1

Using Camlocks

Step 1

Connect the male camlock as directed in the assembly instructions using a screwdriver.

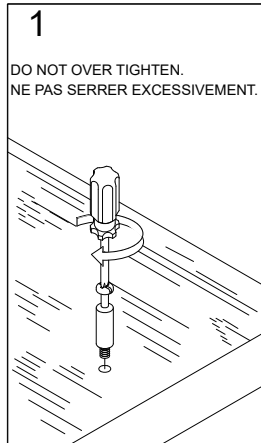

Step 2

Push the male camlock into the entry hole.

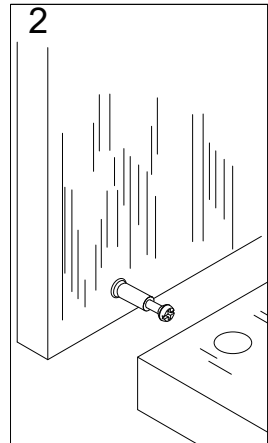

Step 3

Insert the female camlock as shown in the instructions.

Note: ensure that the arrow on the top of the camlock points towards the entry hole for the male camlock.

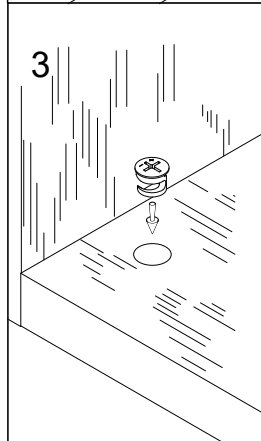

Step 4

Turn the female camlock clockwise with a screwdriver.

You should feel a click when the camlock is locked in place.

The joint is now secure.

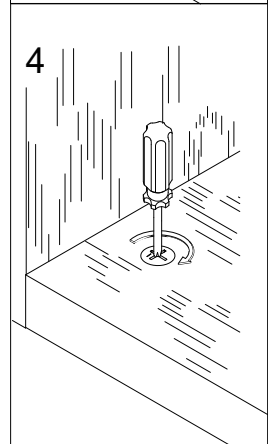

1

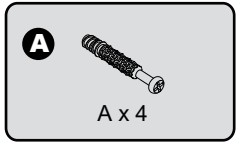

CAM-LOCK

Tighten until shoulder is flush with panel. Do not overtighten or undertighten (see example below)

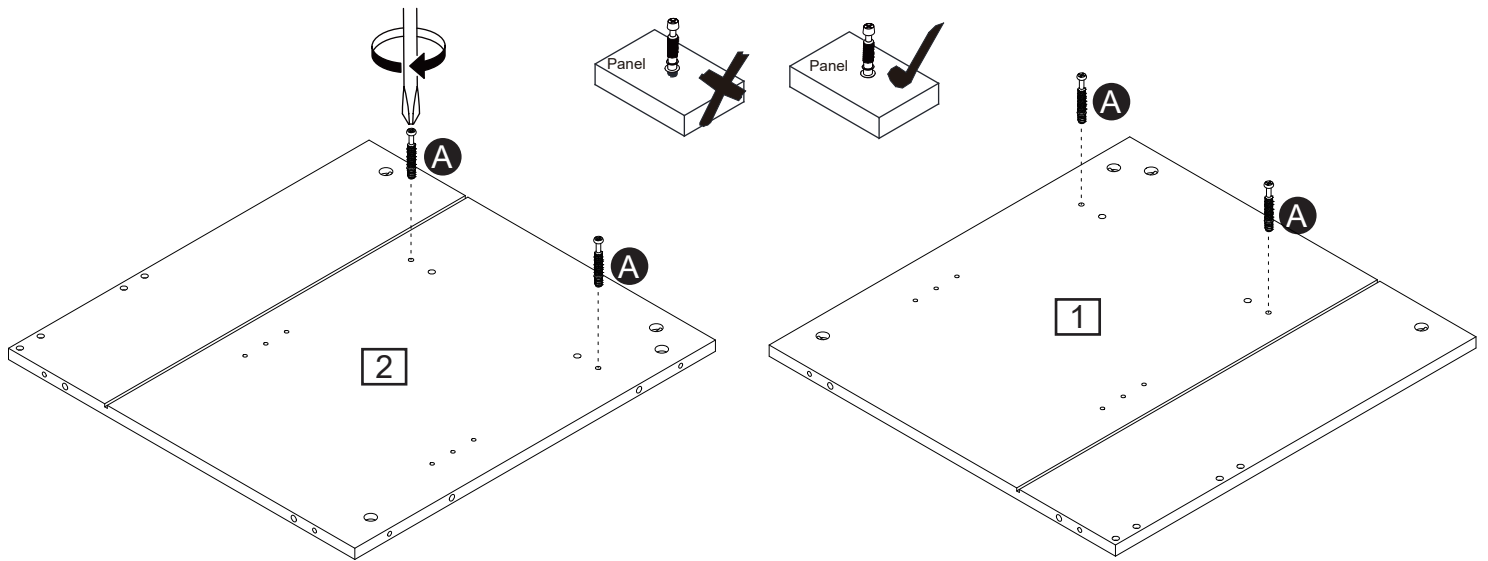
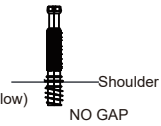

2

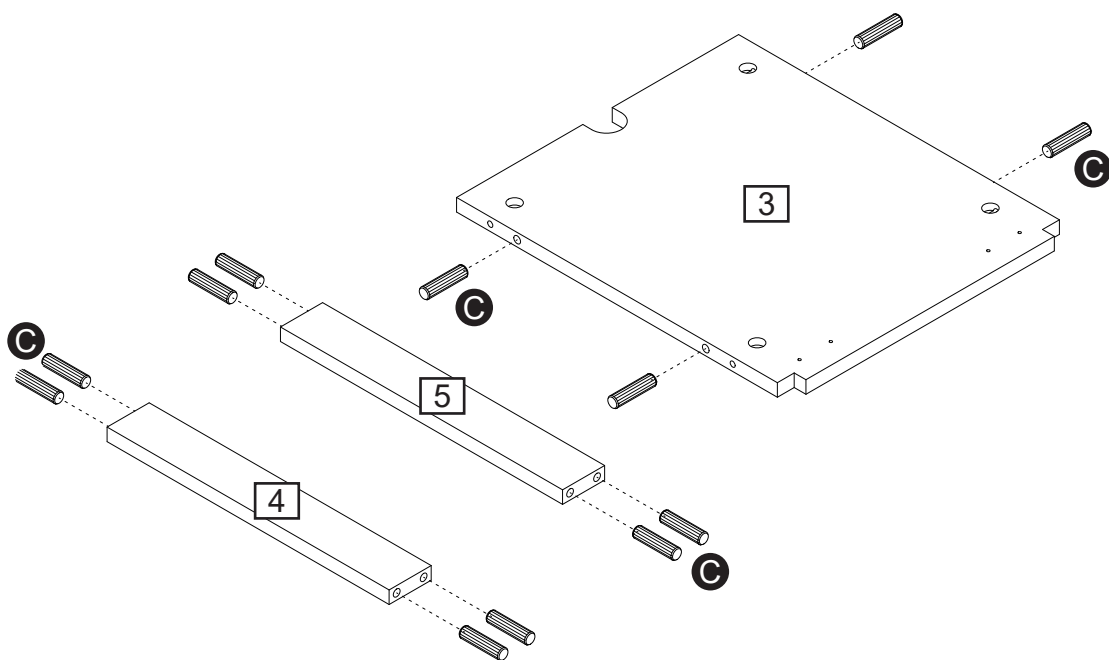
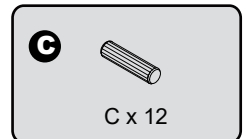

3

Edge Banding Here

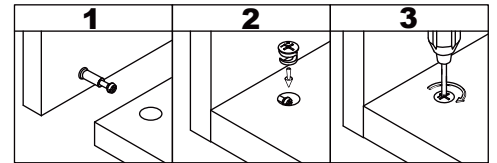
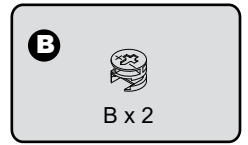
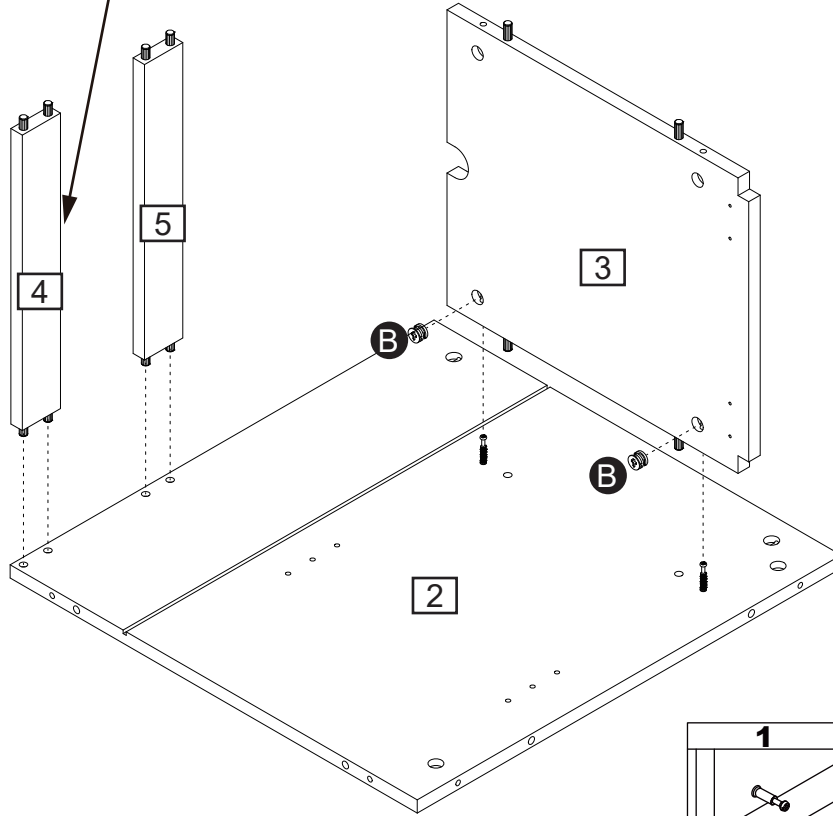

4

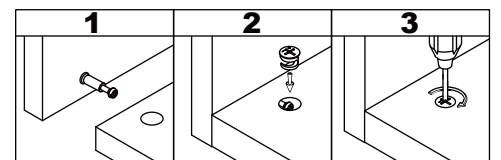
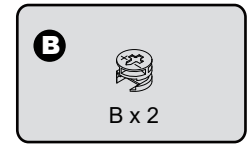
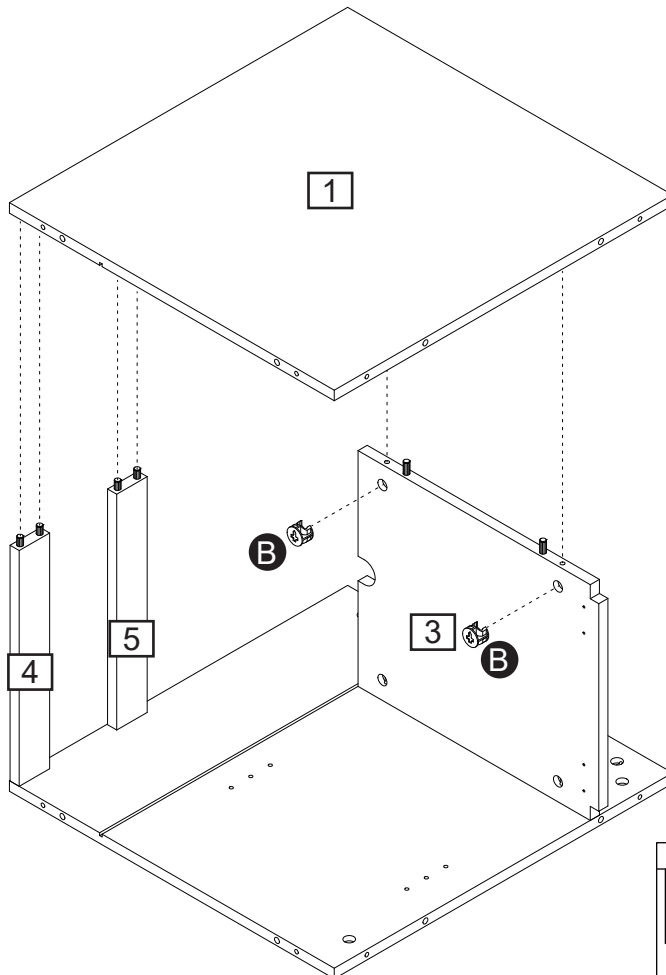

5

CAM-LOCK

Tighten until shoulder is flush with panel. Do not overtighten or undertighten (see example below)

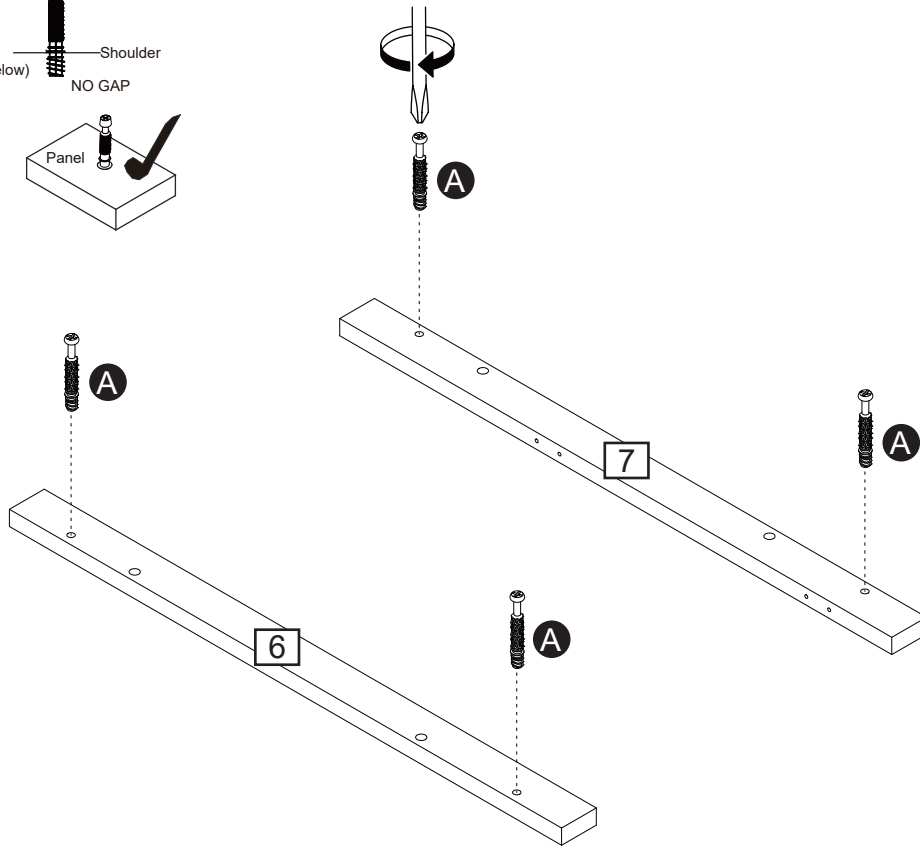
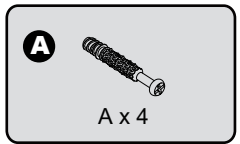
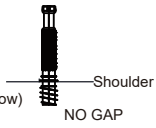
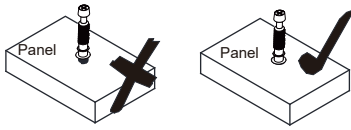

6

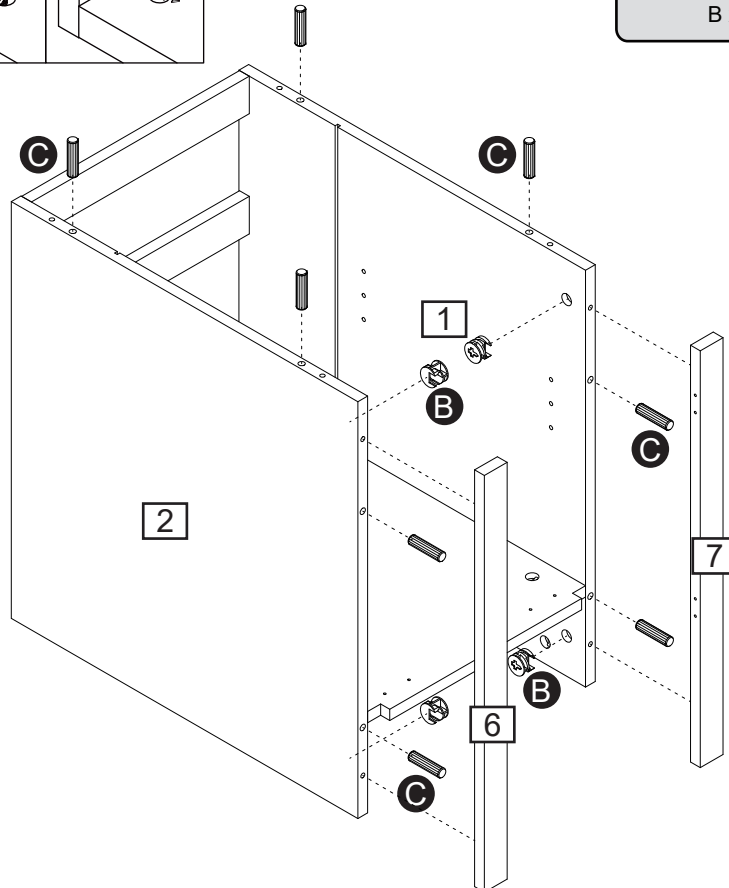
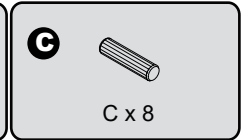
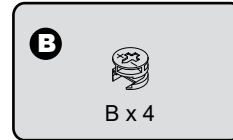
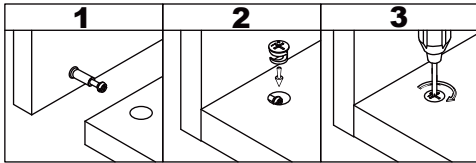

7

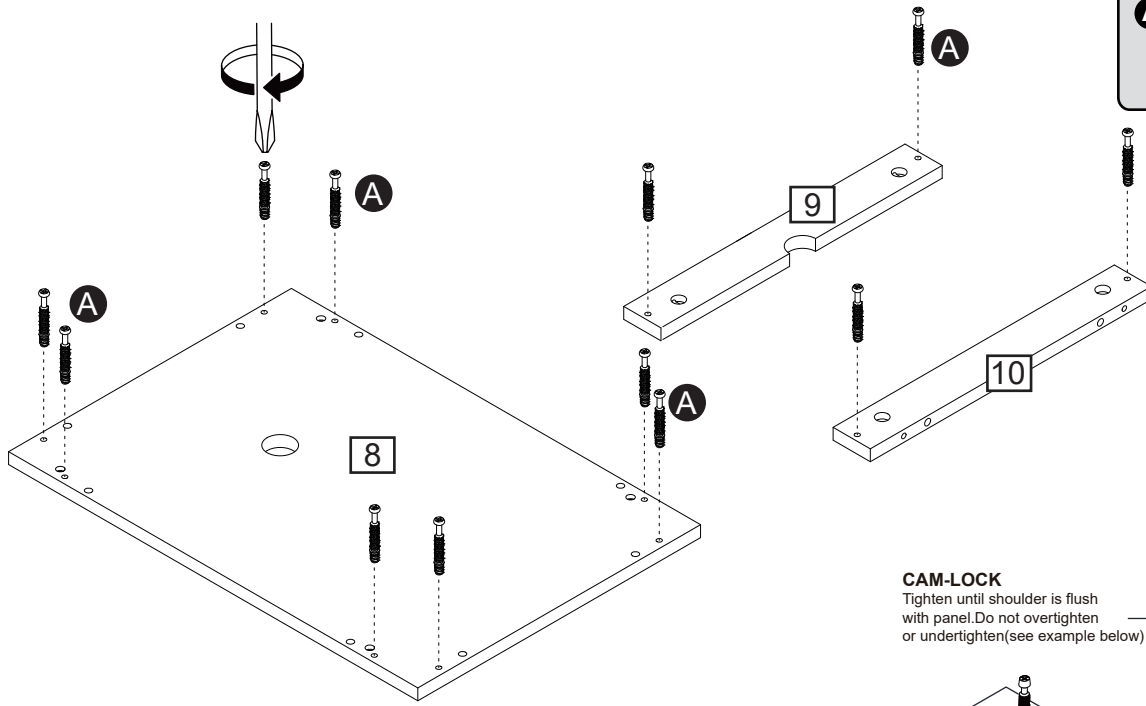

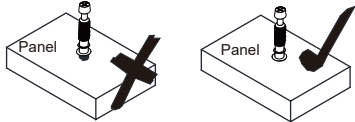
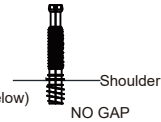

A 
A x 12

CAM-LOCK
Tighten until shoulder is flush with panel. Do not overtighten or undertighten (see example below)

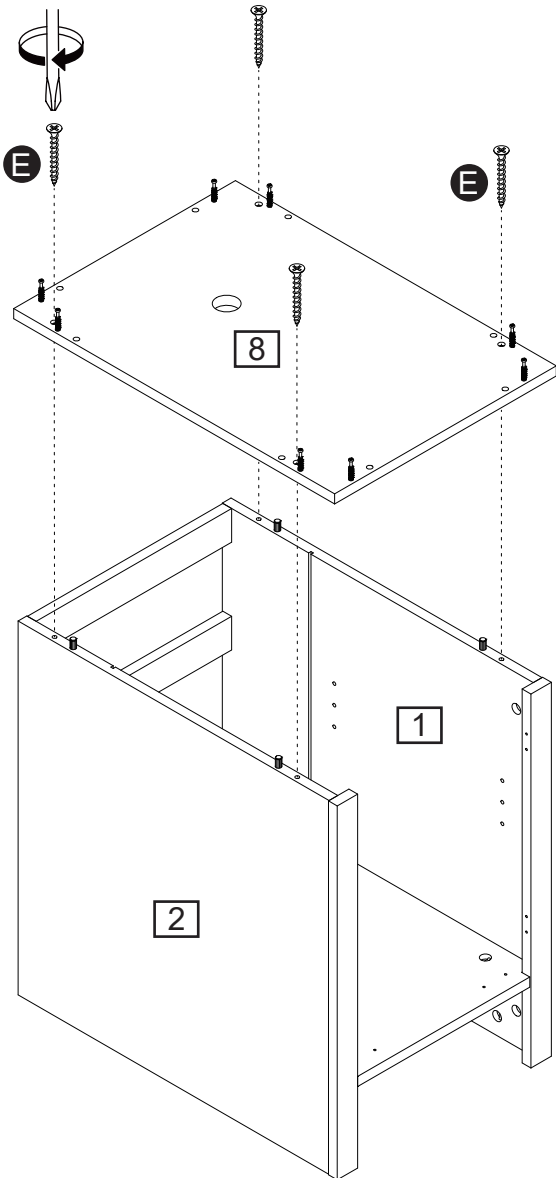

8



E 
E x 4

9

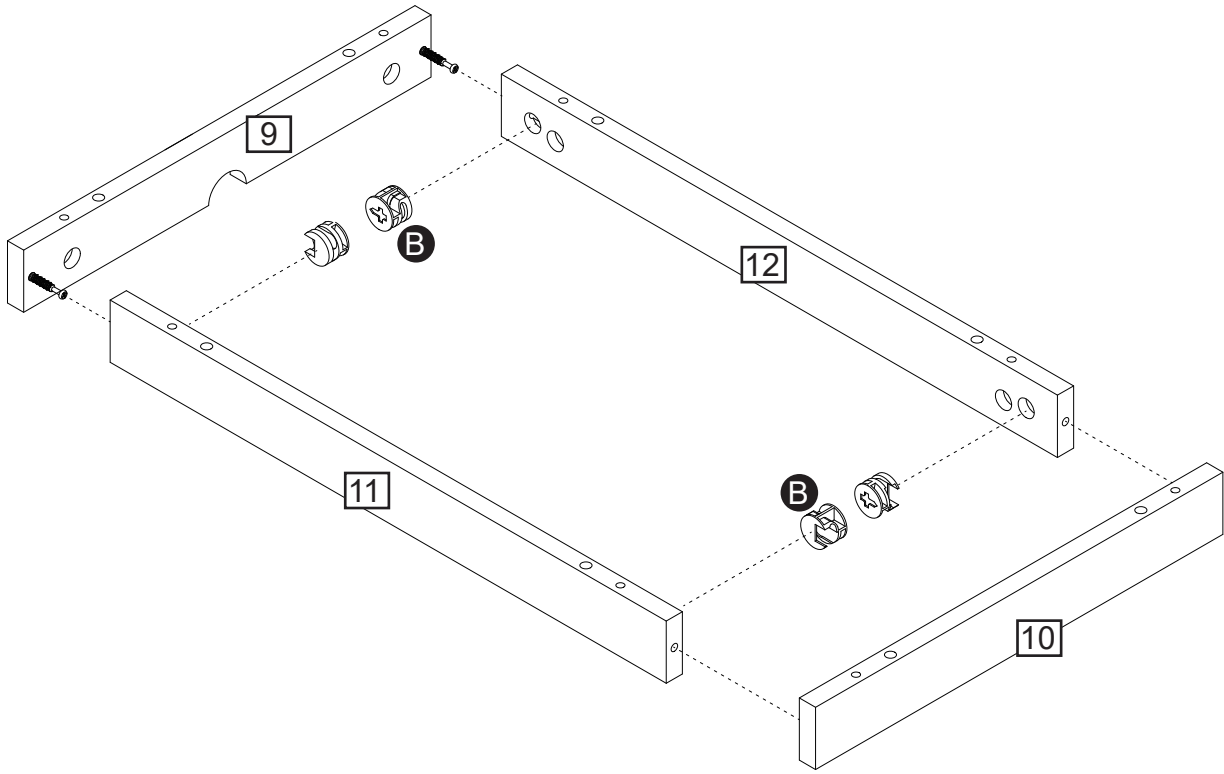
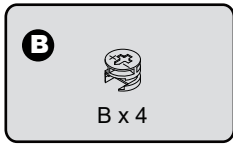
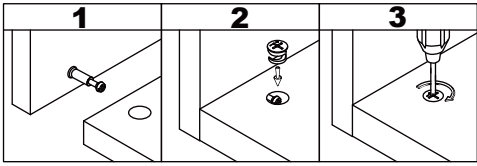

10

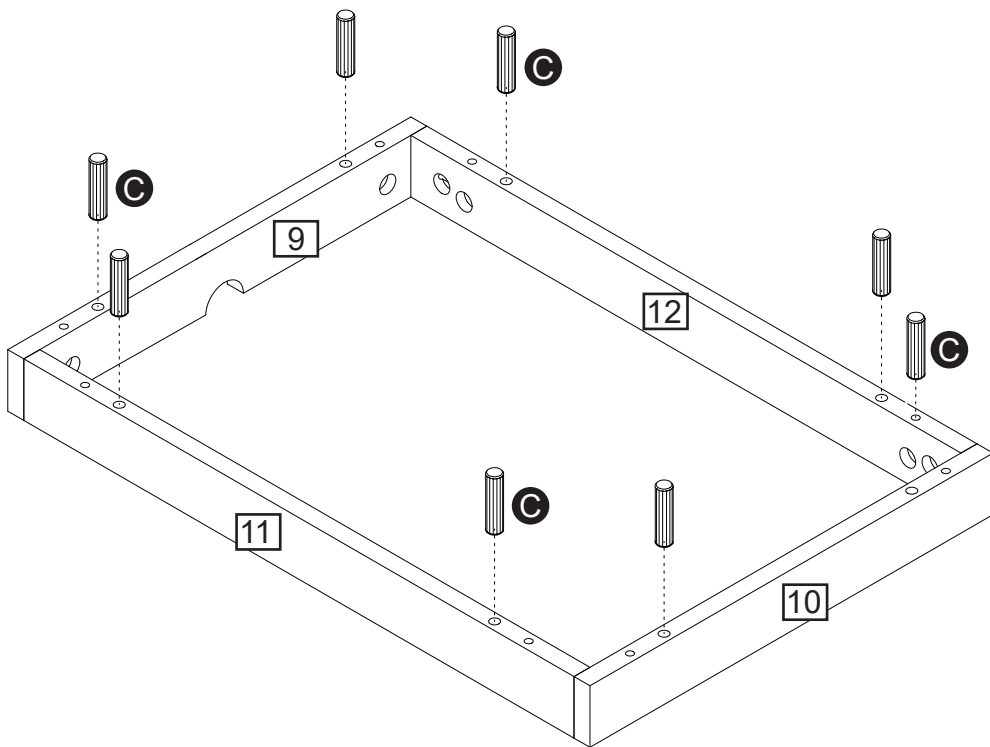
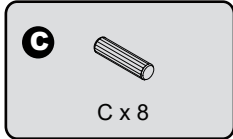

11

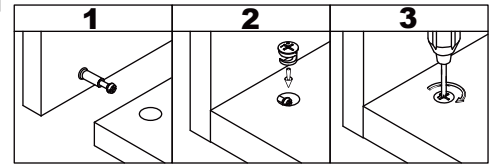
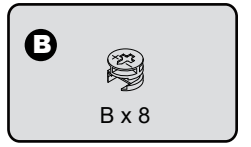
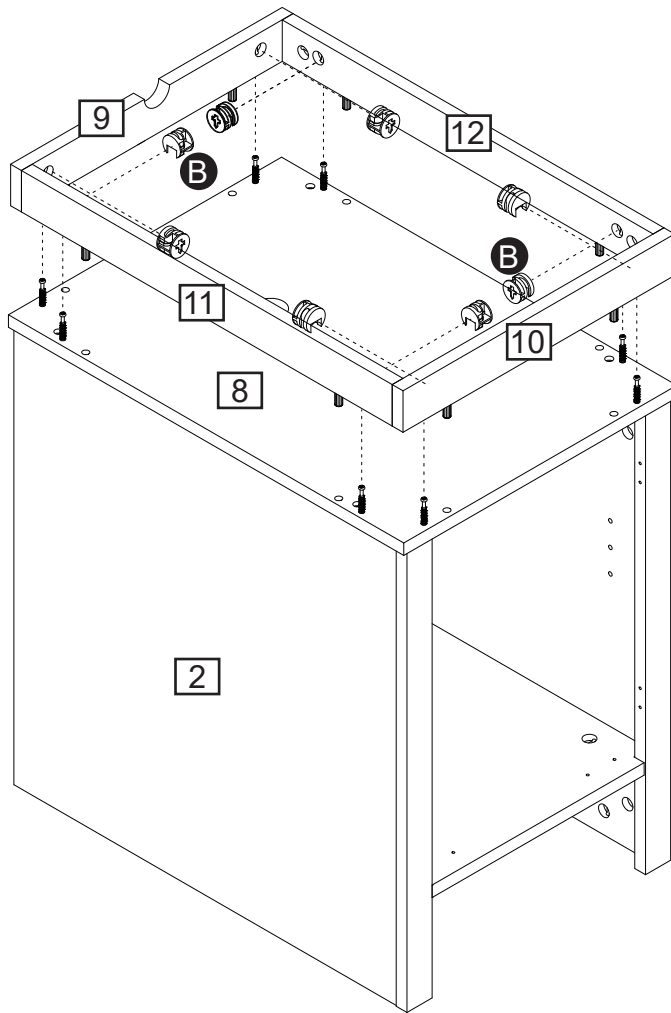

12

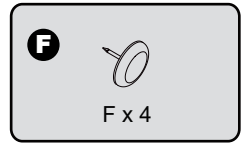
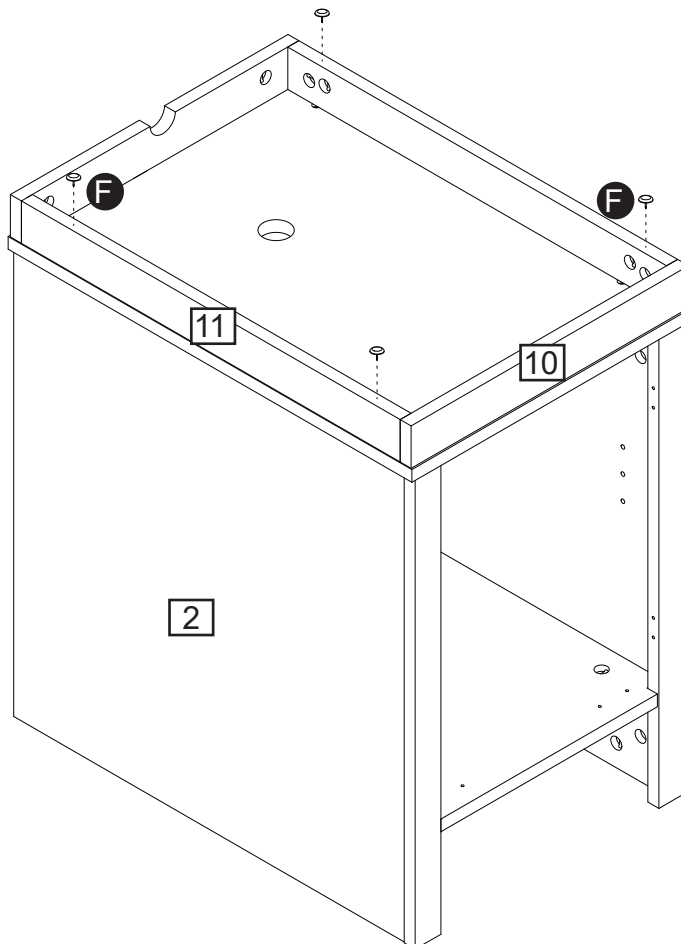

13

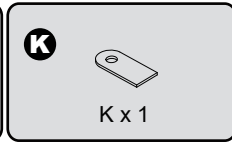
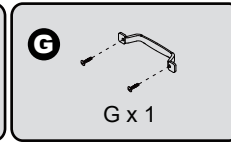
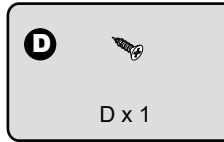

open to the left

or

open to the right

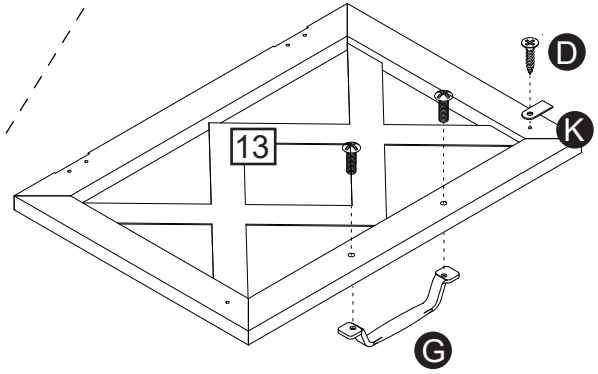
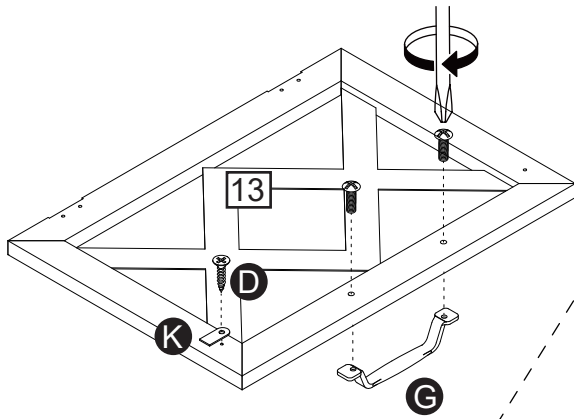

14

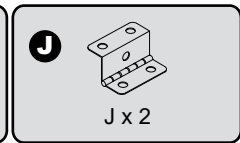

open to the left

or

open to the right

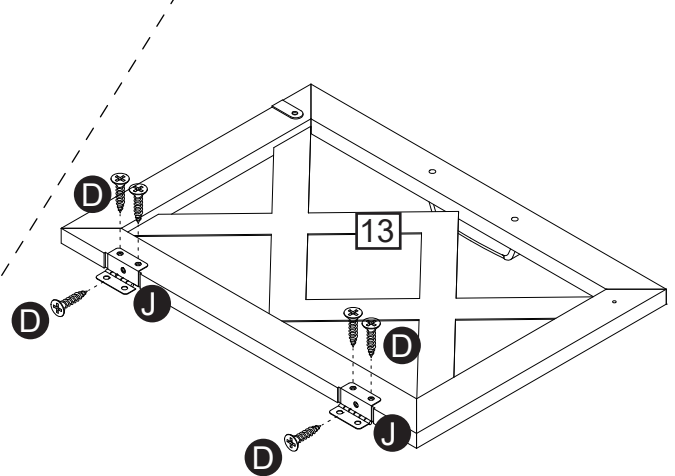
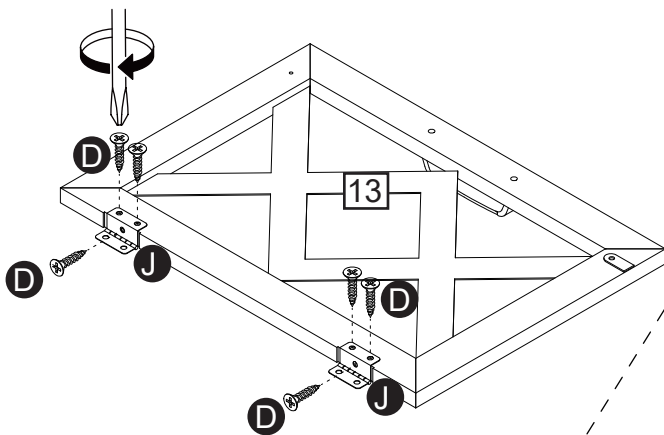

15



open to the left

or

open to the right

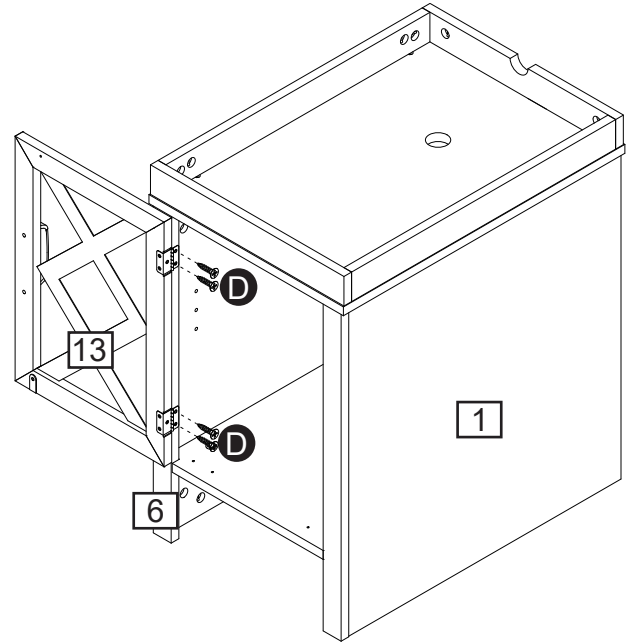
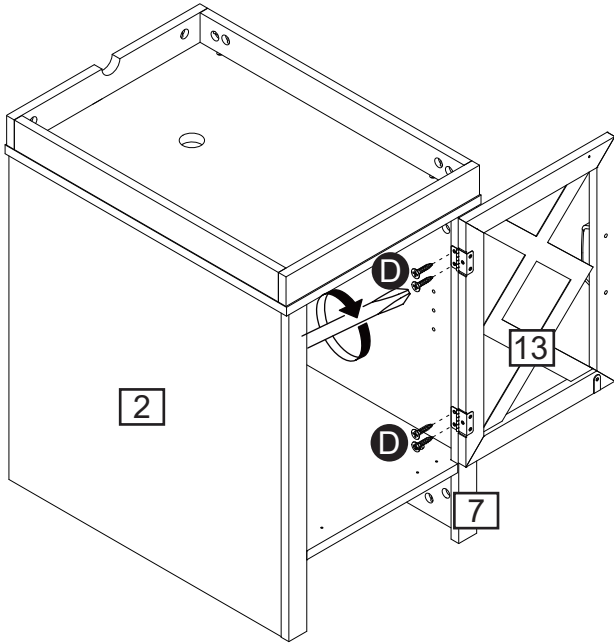

16

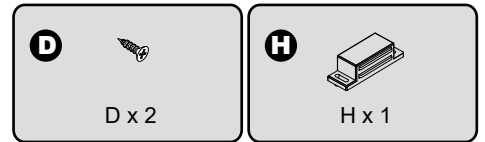

open to the left

or

open to the right

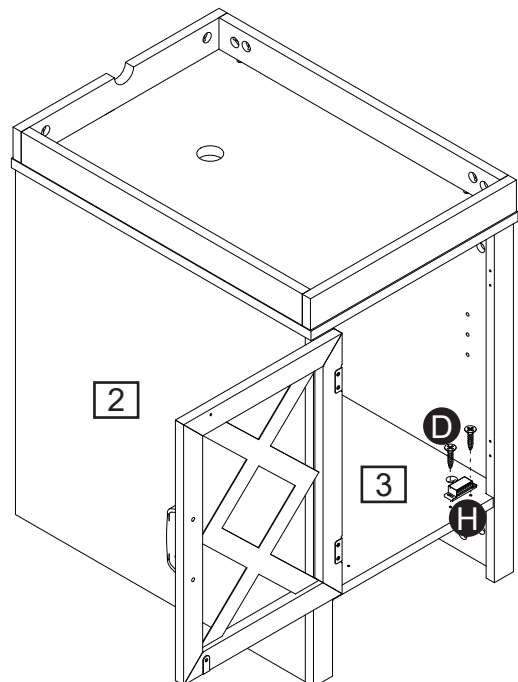
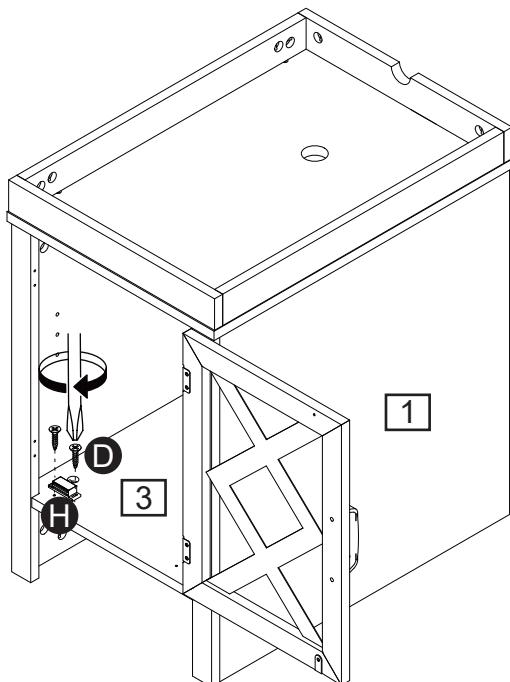

17

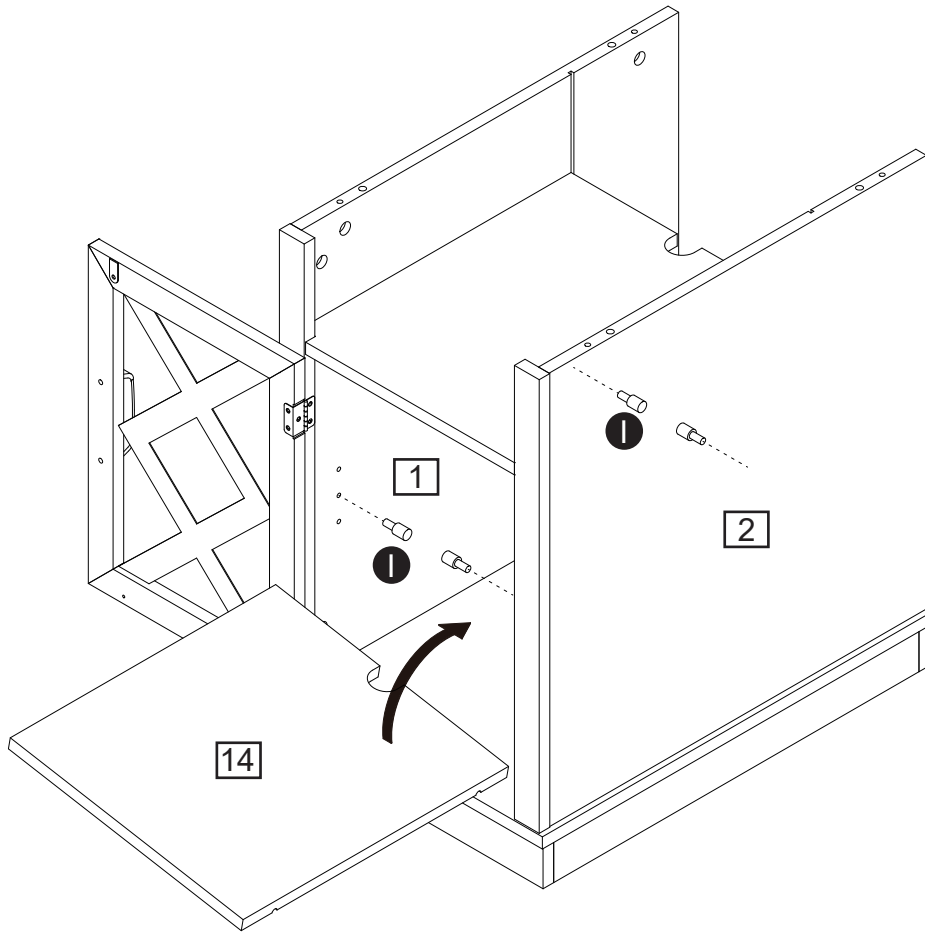
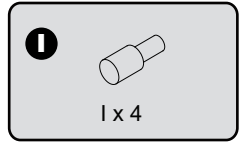

18

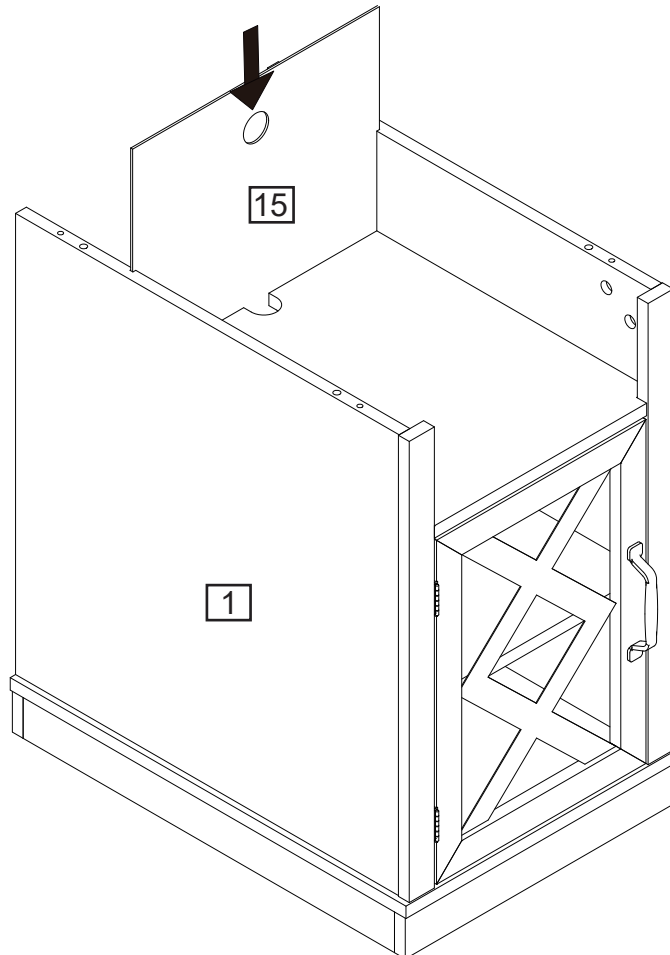

19

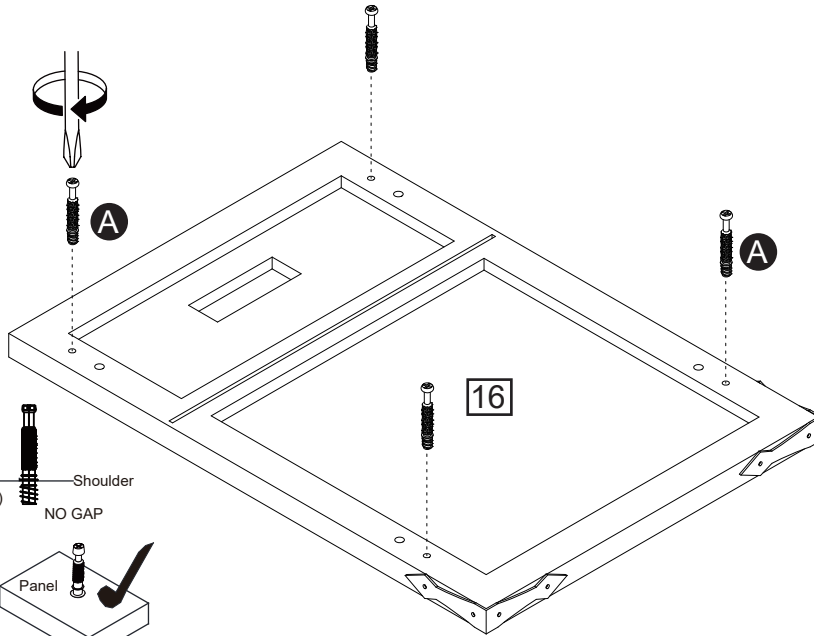
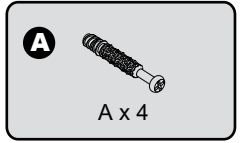

CAM-LOCK

Tighten until shoulder is flush with panel. Do not overtighten or undertighten (see example below)

Shoulder
NO GAP

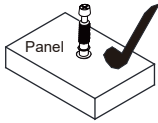
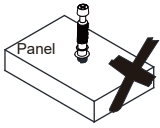

20

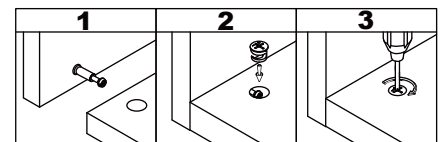
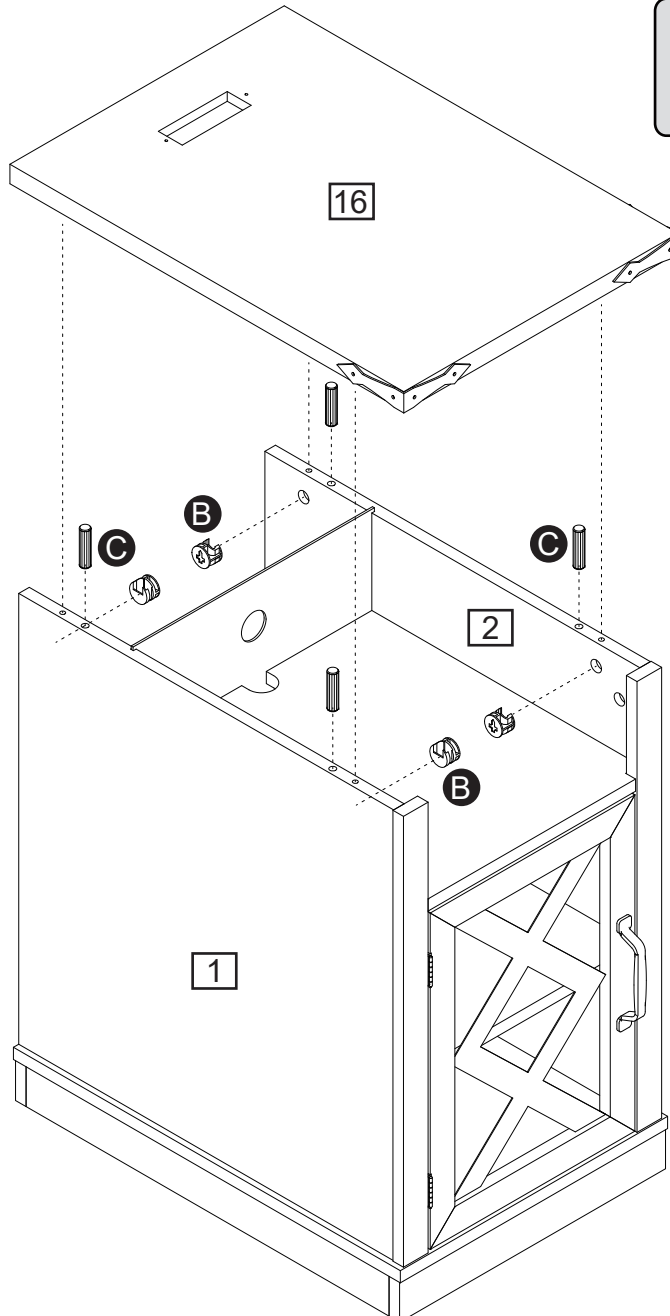
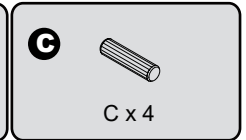
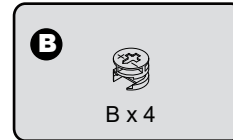

21

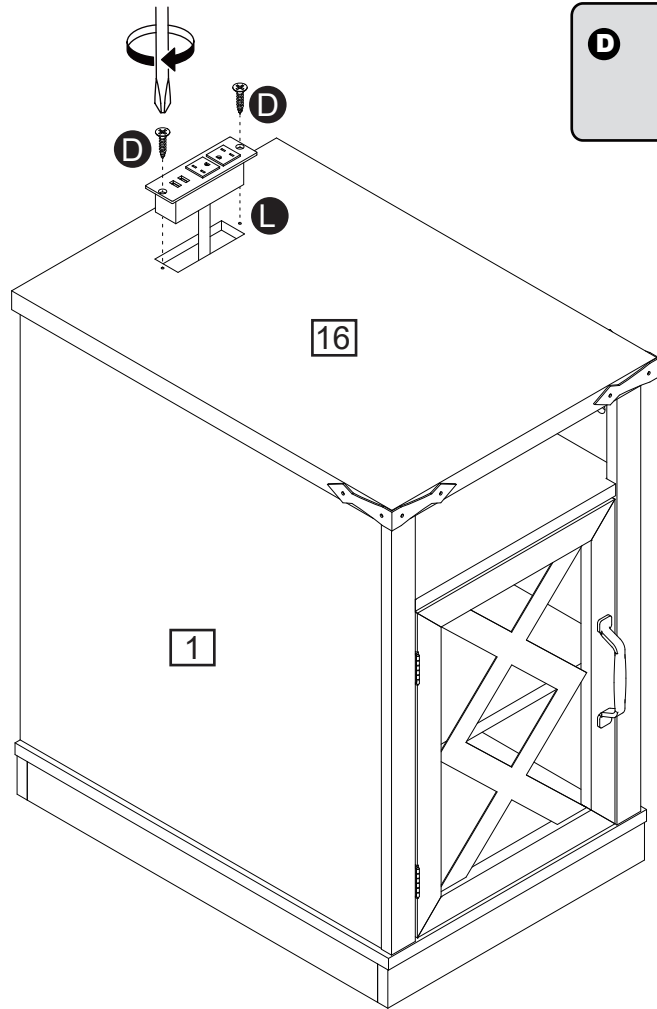

22

