

Assembly Instructions

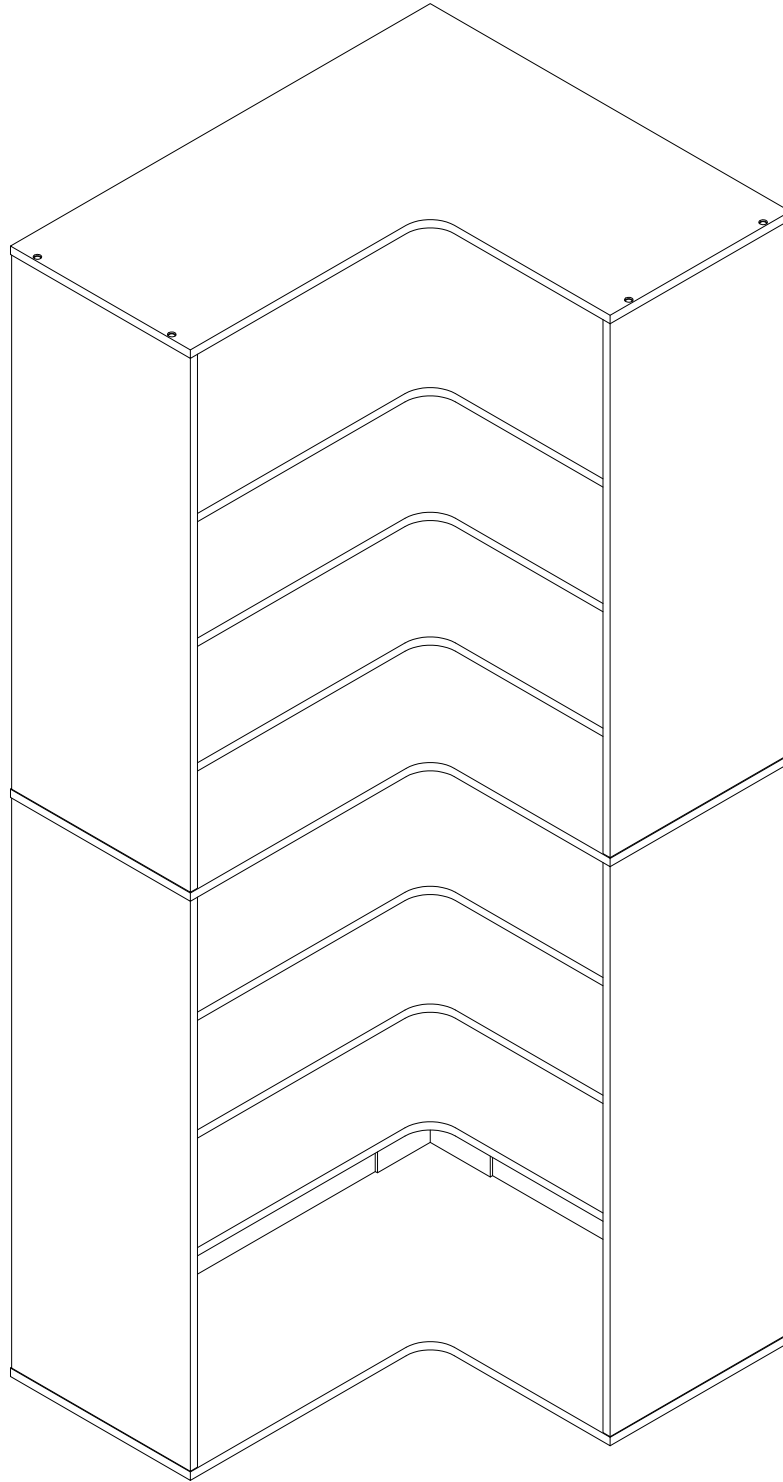

Contact Us

We're here to help you.

Your satisfaction is our top priority. If you encounter any issues with this product, such as missing or damaged parts, we're here to help. Please retain the original packaging and take photos of the packaging and the product, then contact us as soon as possible.

Warm Tips

1. Carefully read these instructions and keep them for future reference.
2. Check the parts list and confirm everything's there before starting assembly.
3. When assembling, put all parts on a soft, smooth surface like a carpet to avoid scratches.
4. Don't fully tighten screws until all parts are confirmed in place to avoid misalignment.

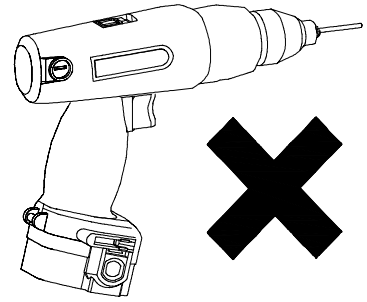
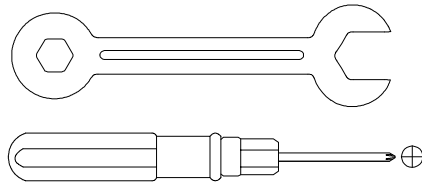
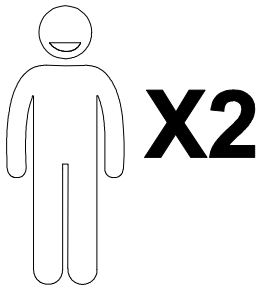

We recommend using hand tools for assembly.

If an electric screwdriver is used, reduce power and torque to avoid damage to the product.

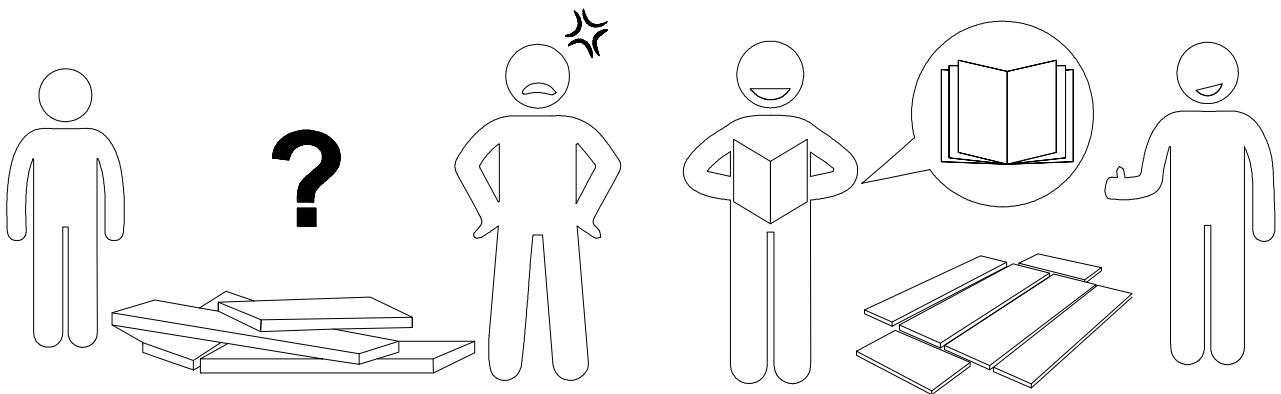

Install the Anti-Tip Straps

Using the anti-tip straps can reduce the risk of tipping over, but can not eliminate it.

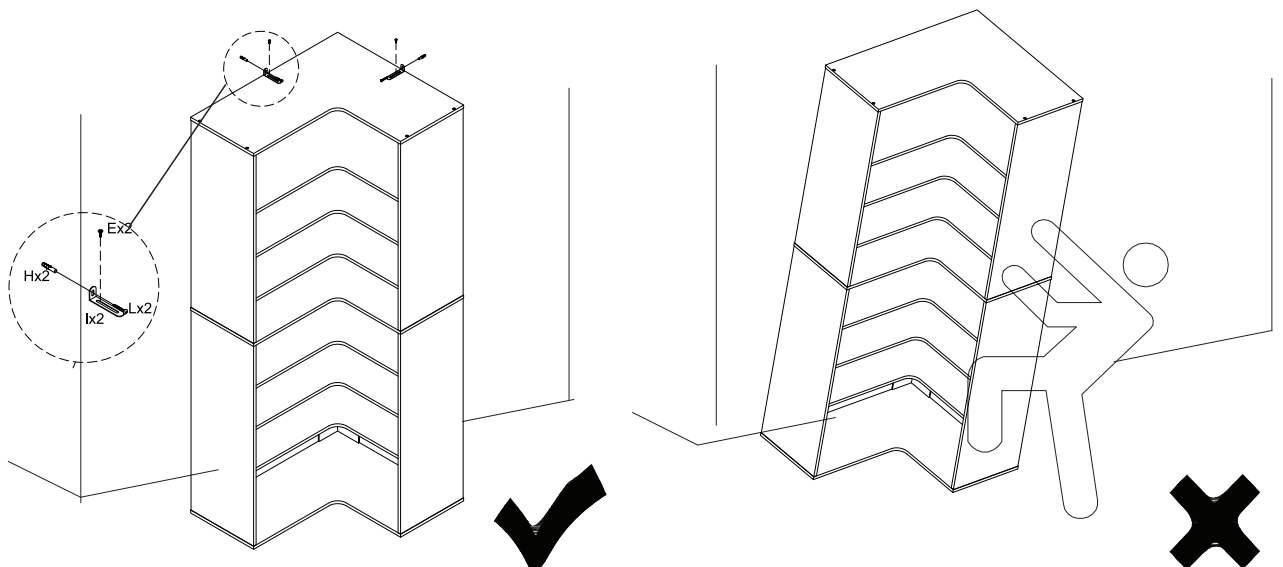

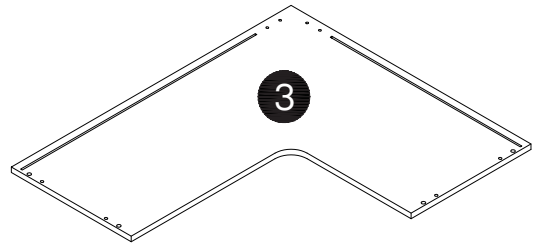
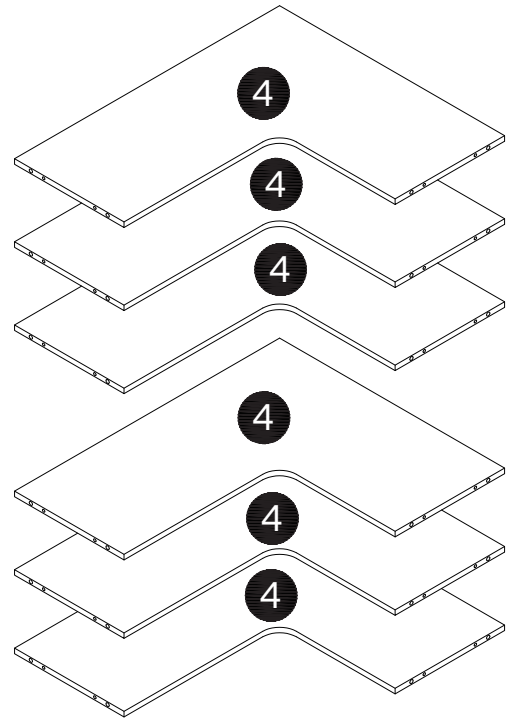
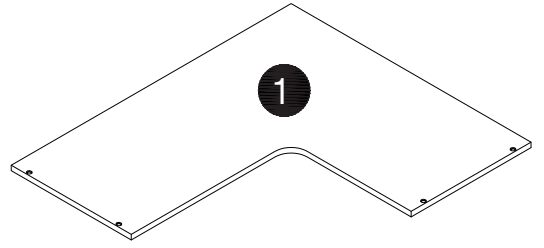
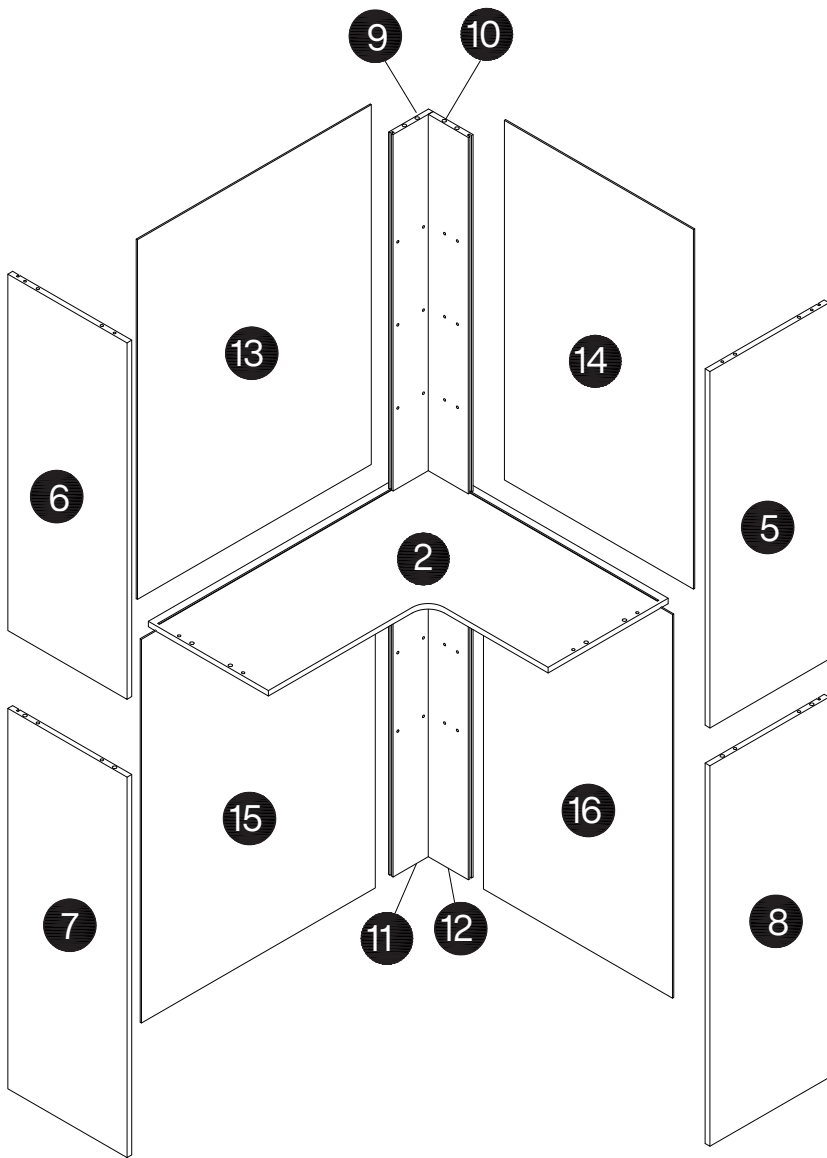





⚠ Caution

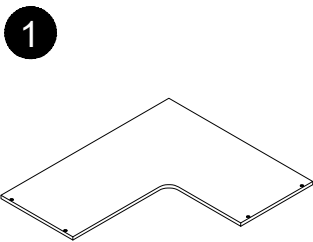
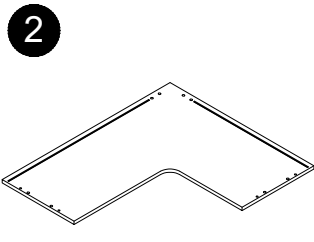
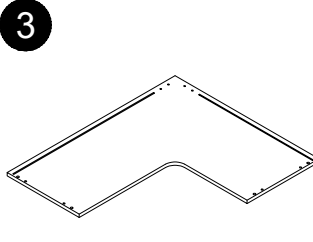
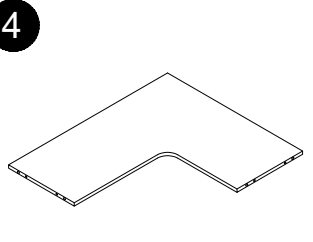
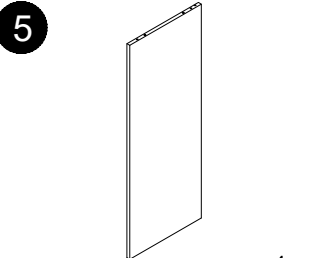
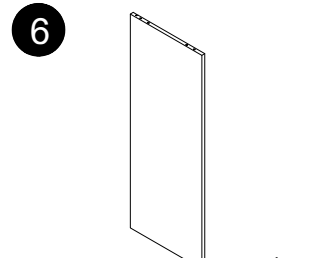
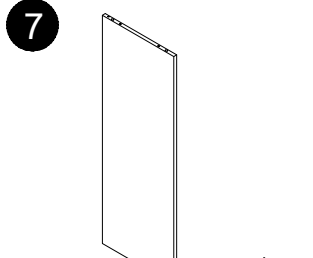
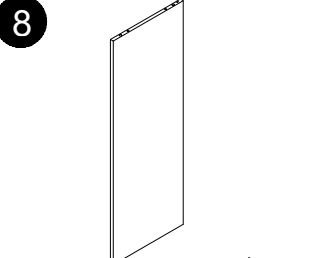
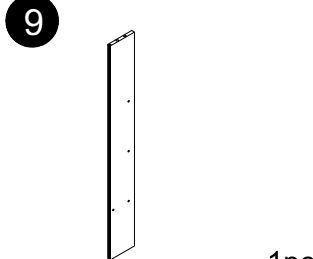
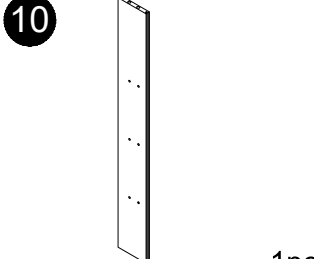
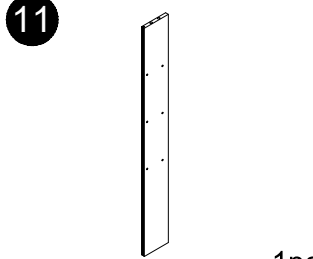
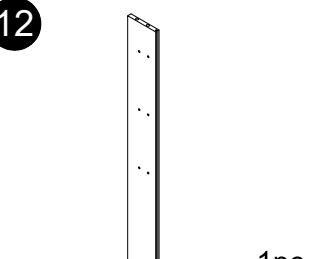
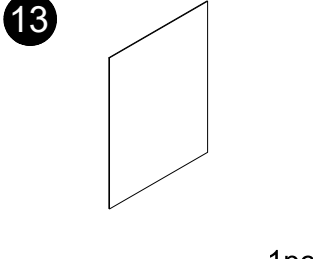
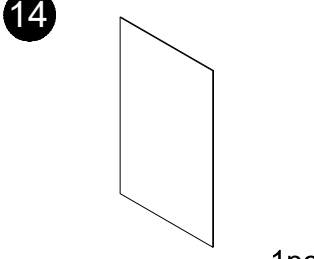
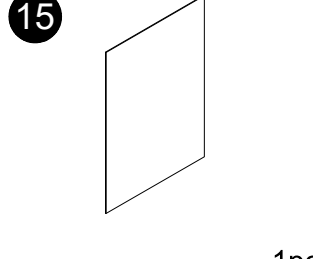
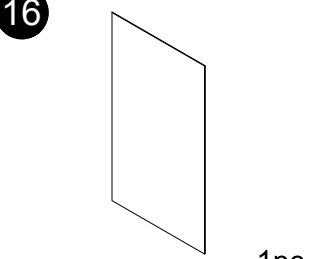

Make sure all parts are included. Most board parts are labeled or stamped on the raw edge. Contact us for a free replacement if you encounter any damaged or missing parts.

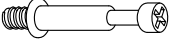
Parts List

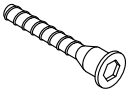
 <p>1</p> <p>1pc</p>	 <p>2</p> <p>1pc</p>	 <p>3</p> <p>1pc</p>	 <p>4</p> <p>6pcs</p>
 <p>5</p> <p>1pc</p>	 <p>6</p> <p>1pc</p>	 <p>7</p> <p>1pc</p>	 <p>8</p> <p>1pc</p>
 <p>9</p> <p>1pc</p>	 <p>10</p> <p>1pc</p>	 <p>11</p> <p>1pc</p>	 <p>12</p> <p>1pc</p>
 <p>13</p> <p>1pc</p>	 <p>14</p> <p>1pc</p>	 <p>15</p> <p>1pc</p>	 <p>16</p> <p>1pc</p>

Hardware List

A	B	C	D	E	F
 M6x35mm	 Ø15x10mm	 Ø6x30mm	 Ø5x40mm	 Ø3.5x14mm	 Ø4x35mm
40pcs	40pcs	32pcs	16pcs	18pcs	24pcs

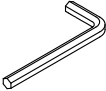
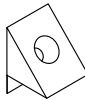
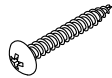
G	H	I	J	K	L
 Ø6x50mm					 Ø4x40mm
4pcs	2pcs	2pcs	1pc	16pcs	2pcs

M

48pcs

Installation of Cams and Pins

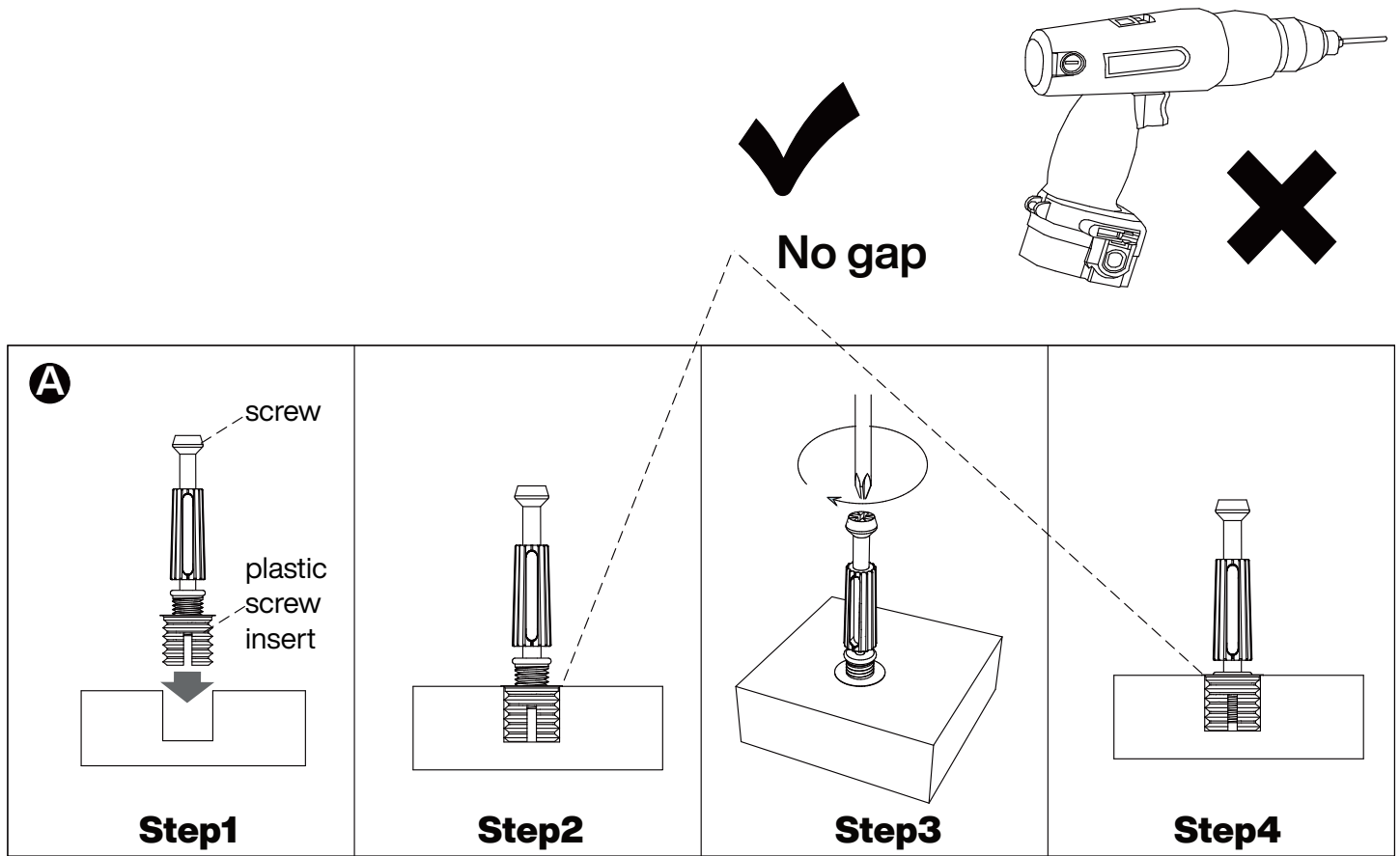
Step 1-2: Align the plastic part with the mounting hole and press it in. If you can't press it in, loosen the screw counter clockwise or completely remove the screw from the plastic part and try again.
Step 3-4: After pressing the plastic part into place, use a screwdriver to tighten the screw clockwise.

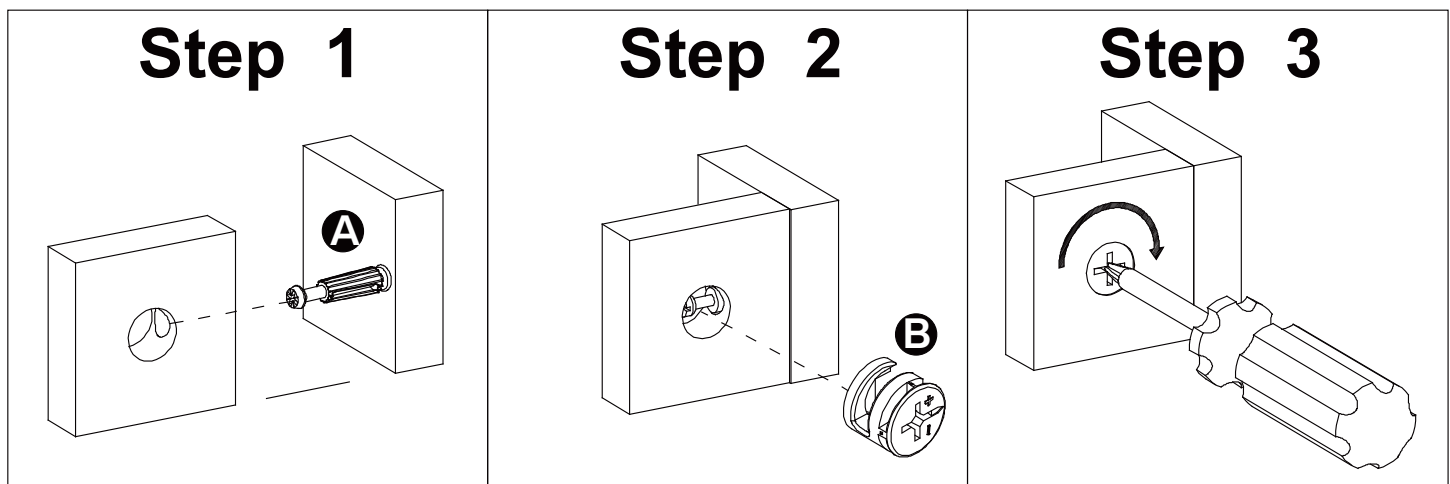

Screw the pin into the hole. Set the cams correctly by aligning the head of the cams with the lock pins. Lock the cam by turning the cam head with a screwdriver until it is tightened. Please do not use an electric screwdriver to assemble the unit.



1

F
 Ø4x35mm
12 pcs

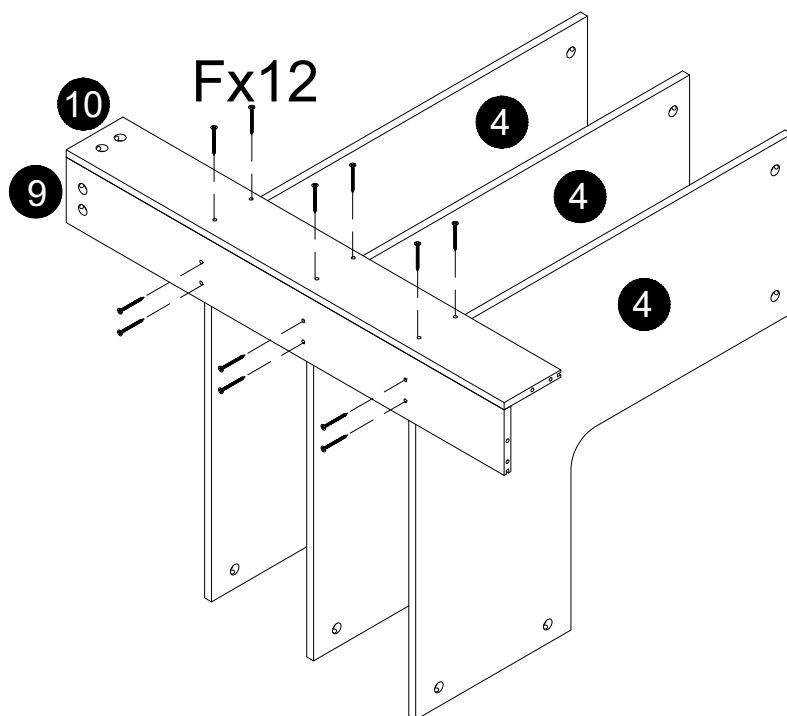

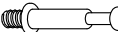

2

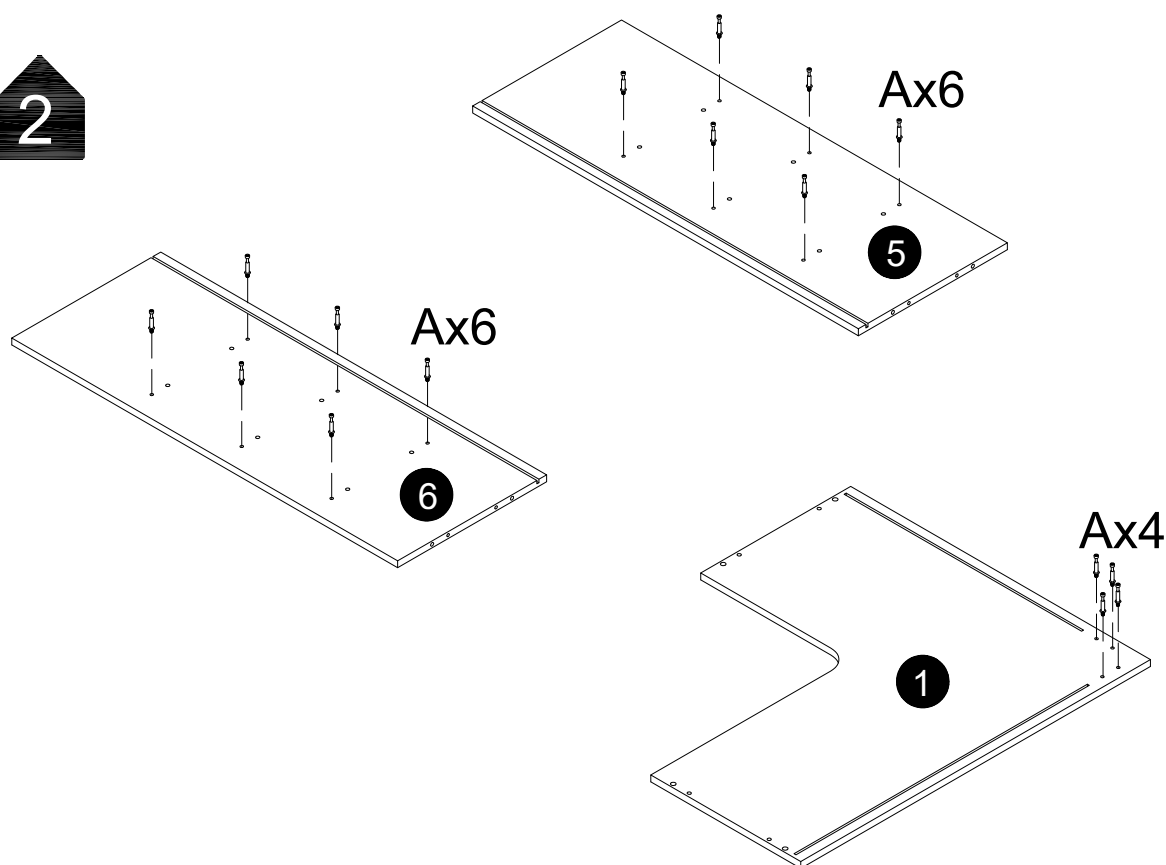
A
 M6x35mm
16 pcs



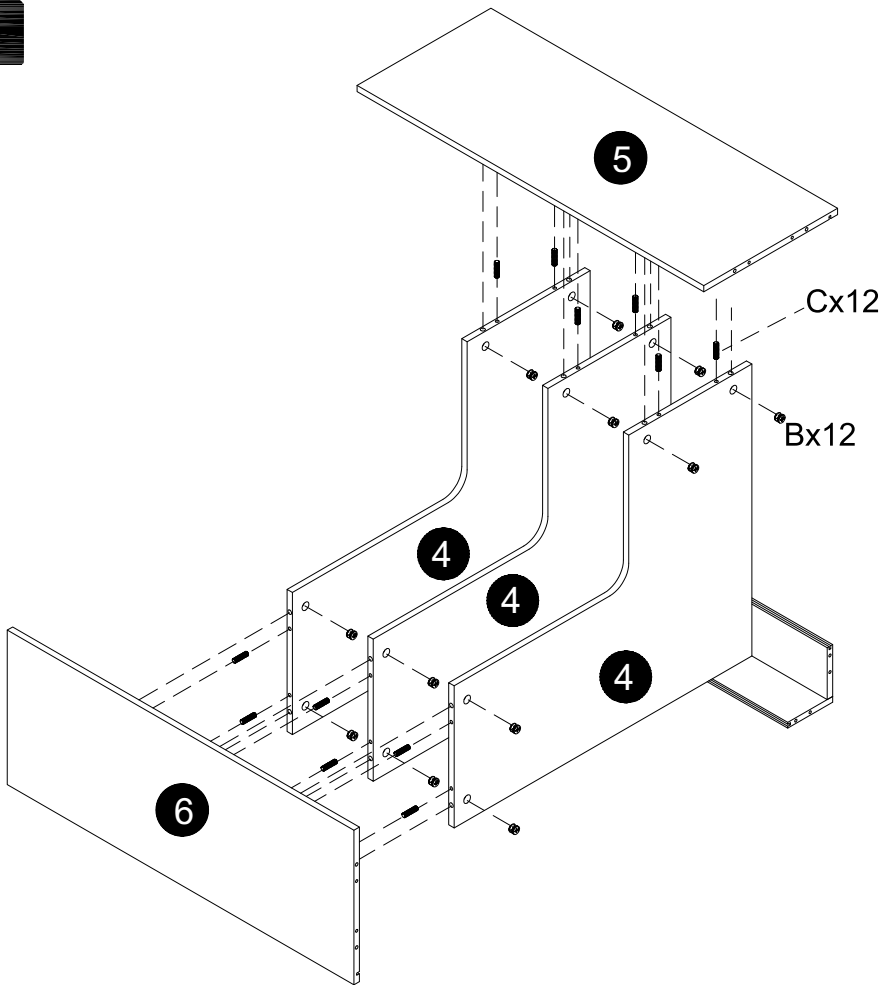



3

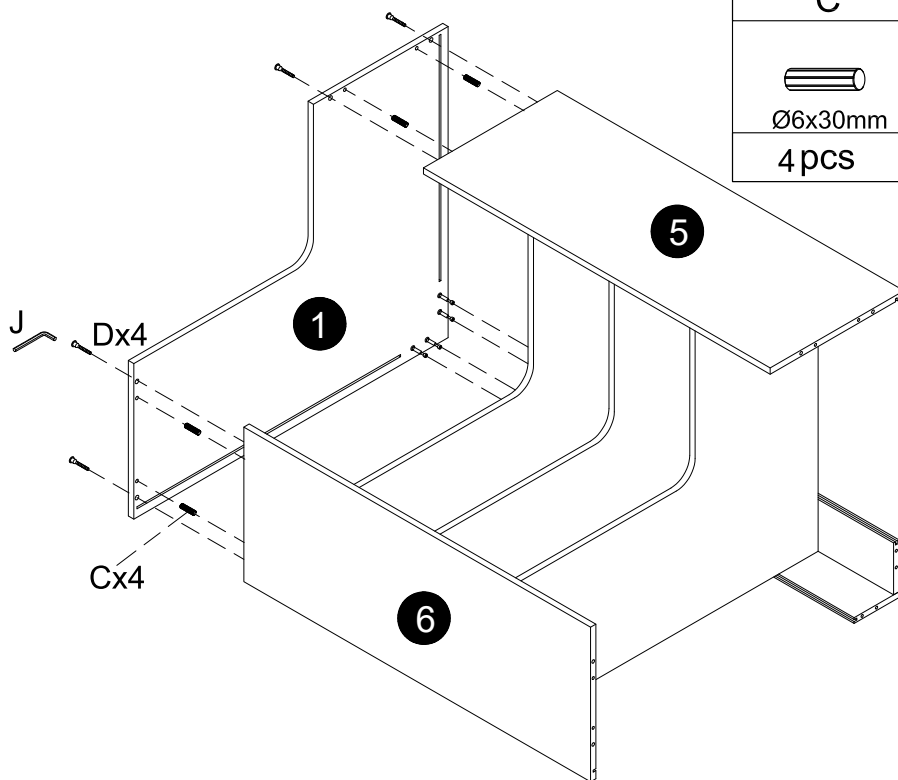

B	C
 Ø15x10mm	 Ø6x30mm
12 pcs	12 pcs

4

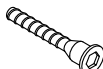

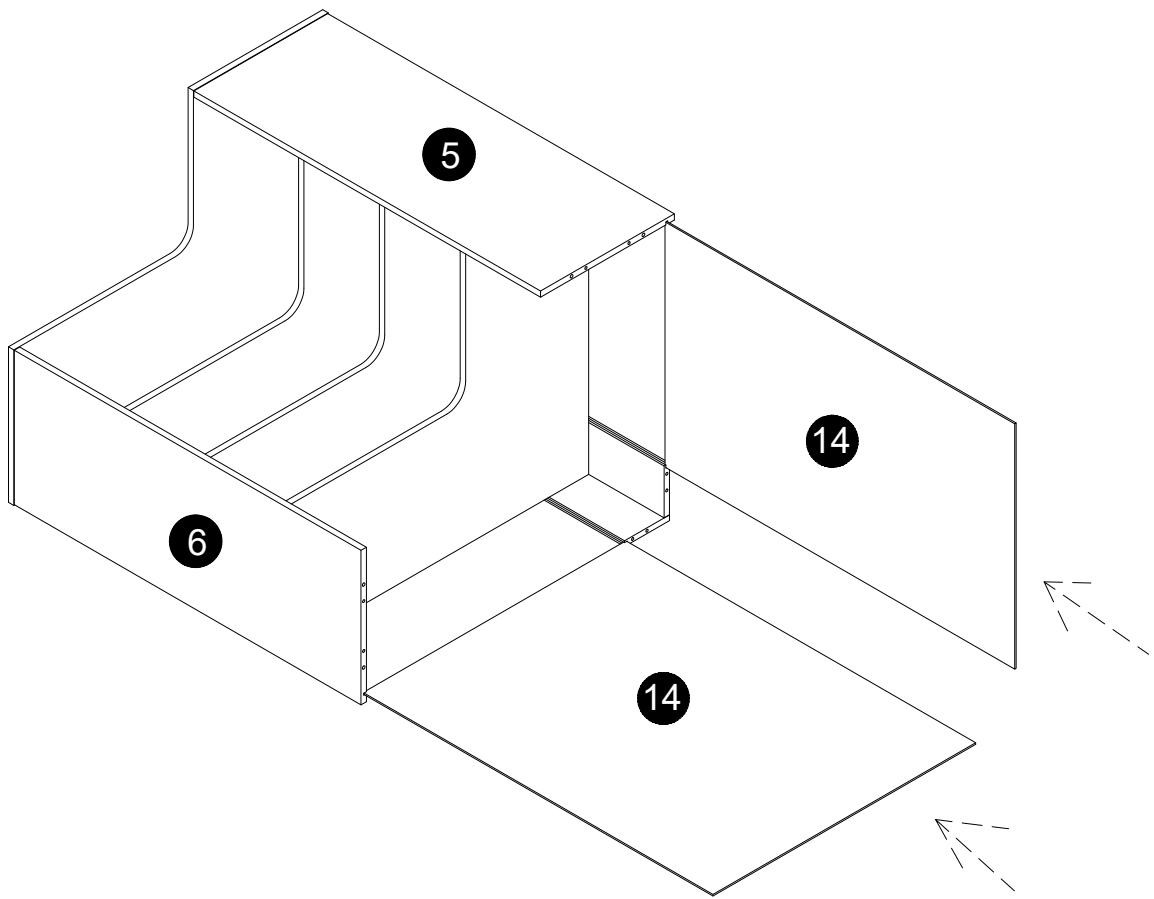

C	D	J
 Ø6x30mm	 Ø5x40mm	
4 pcs	4 pcs	1 pc

5

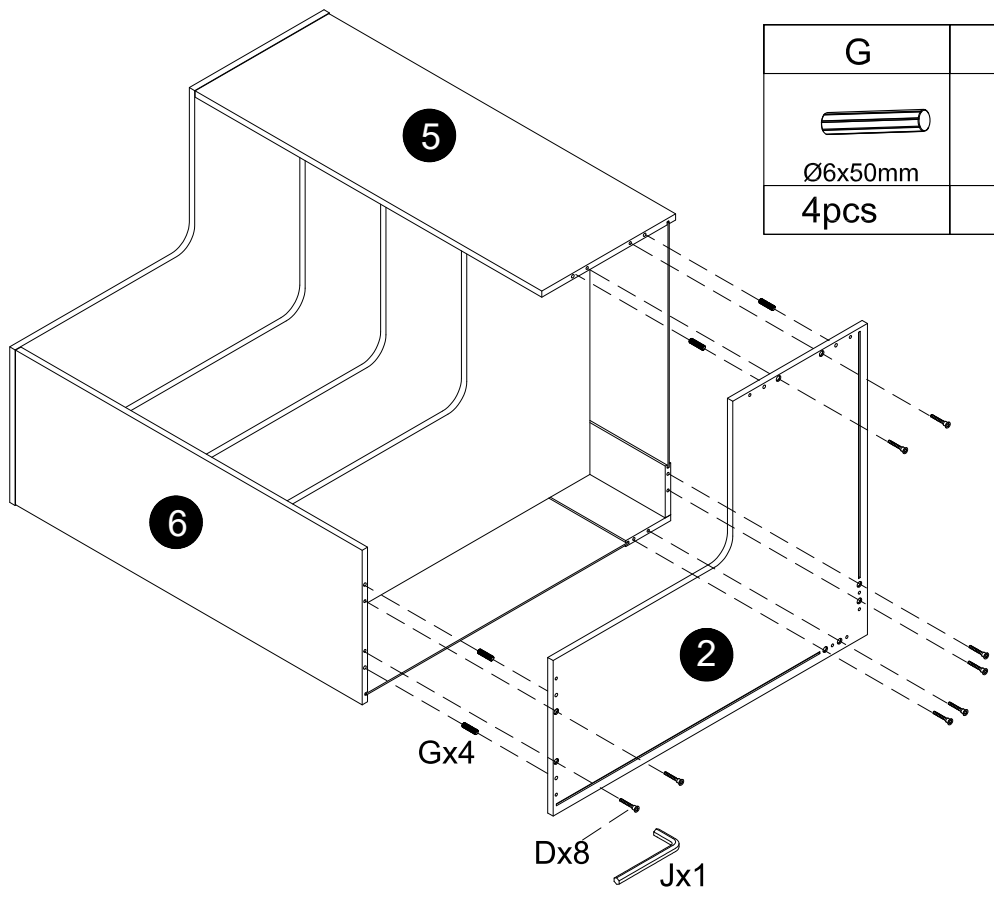

6

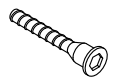

G	J	D
		
Ø6x50mm		Ø5x40mm
4pcs	1pc	8 pcs

7

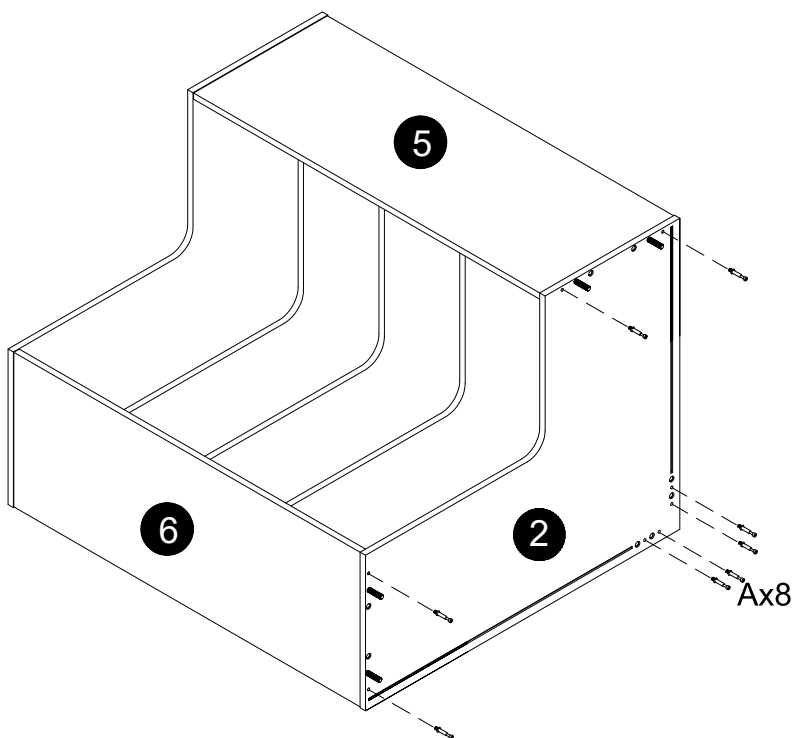

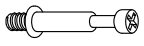
A

M6x35mm
8 pcs

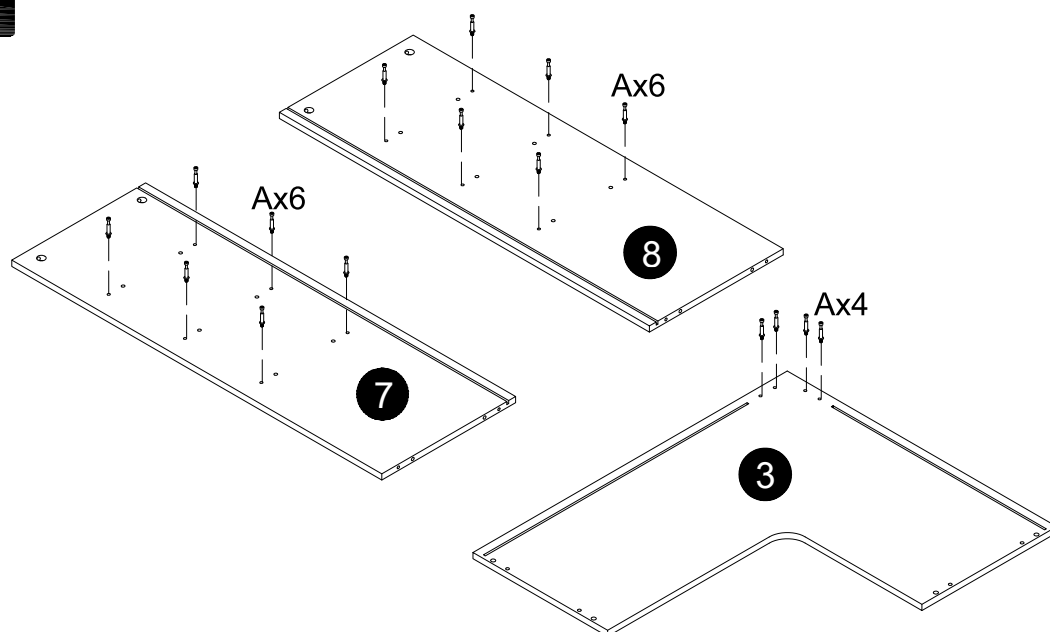
8

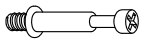

A

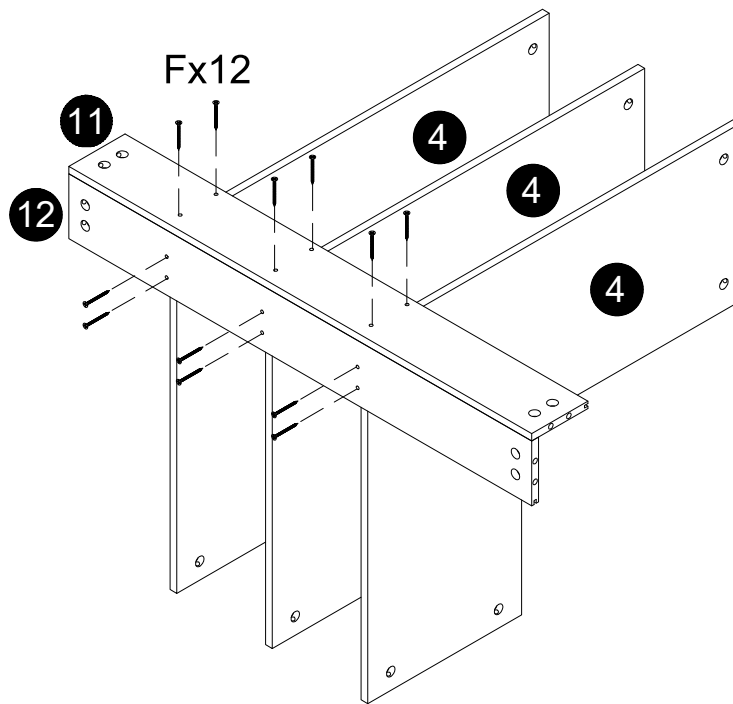
M6x35mm
16 pcs



9

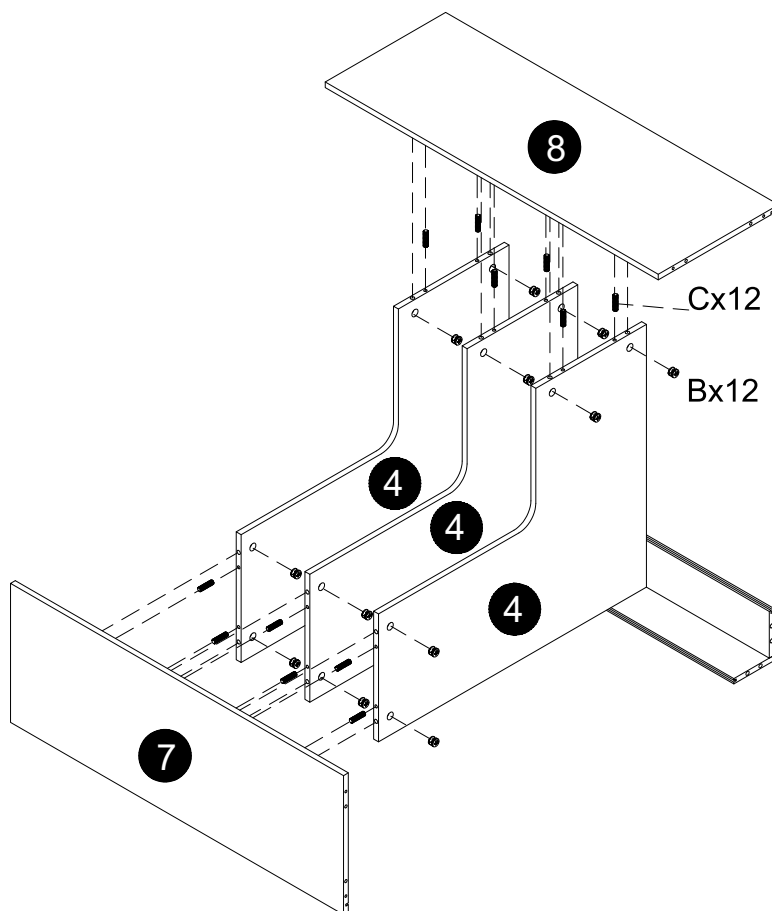

F

Ø4x35mm
12 pcs

10

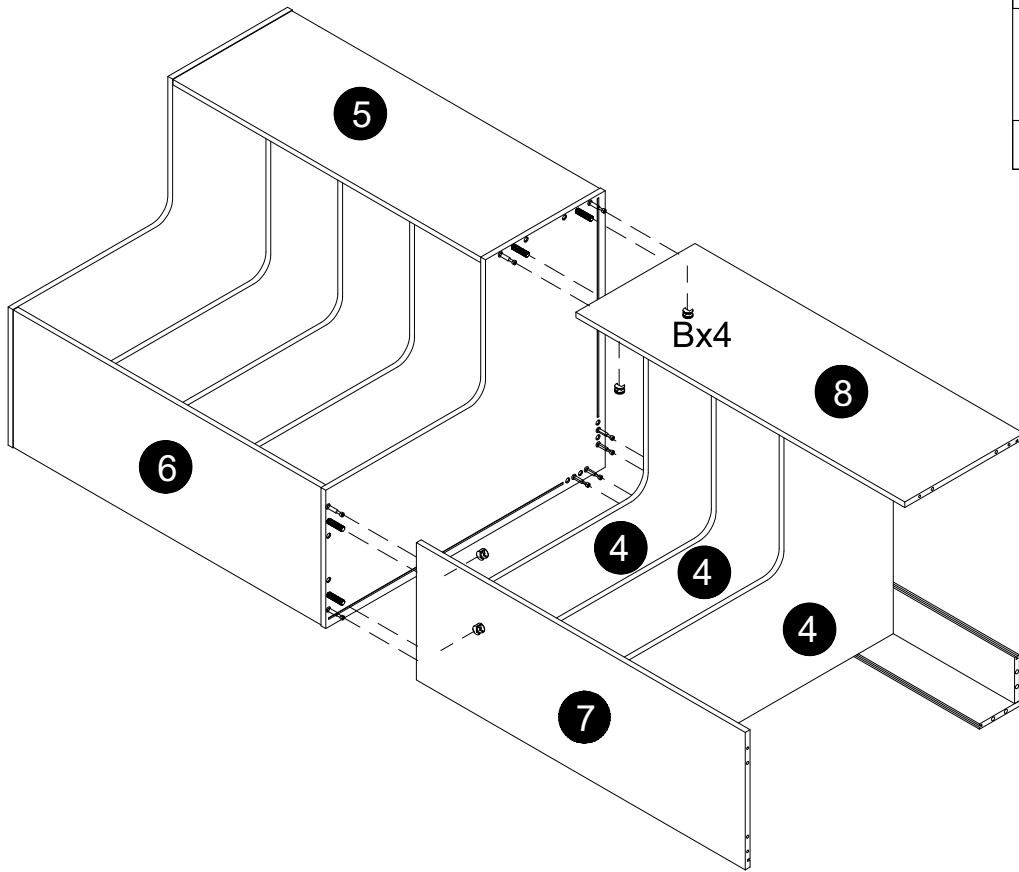

B	C
	
Ø15x10mm	Ø6x30mm
12 pcs	12 pcs

11



12

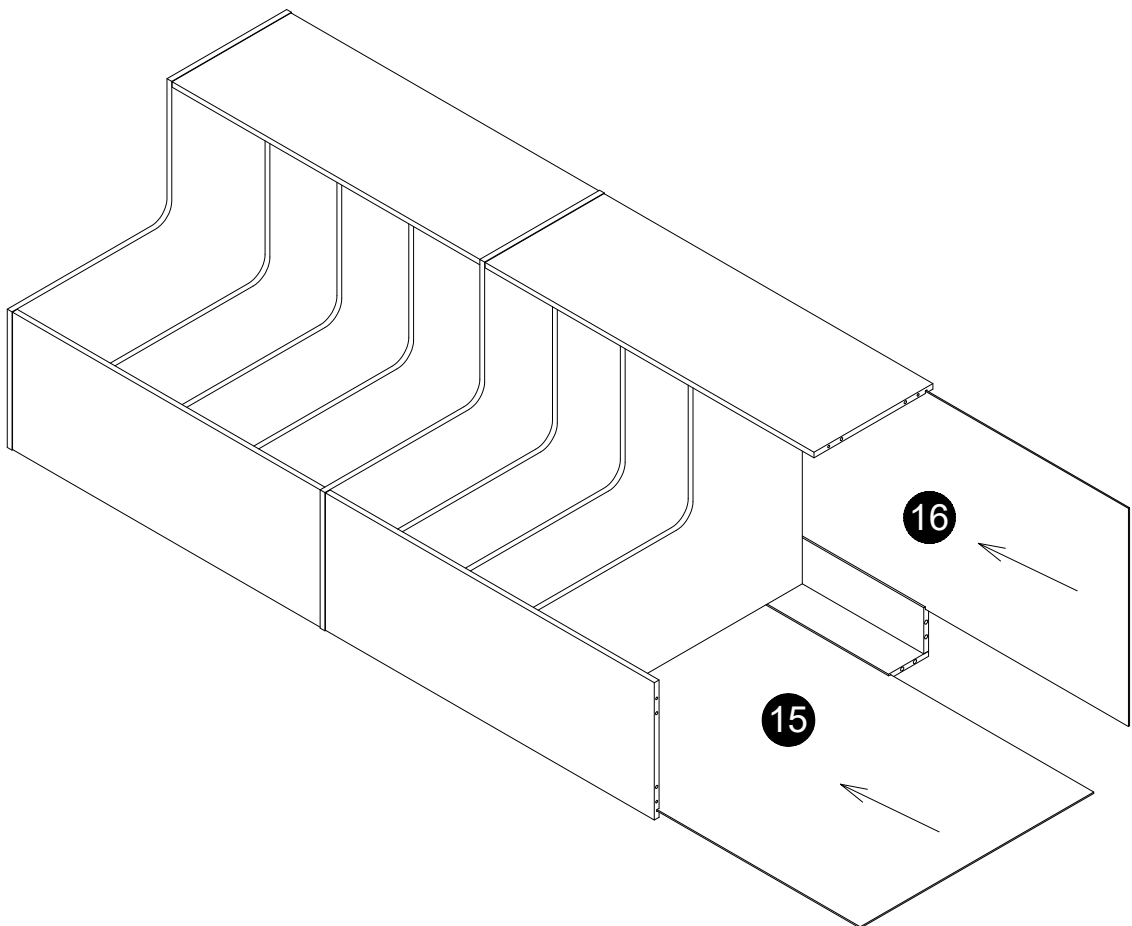

13

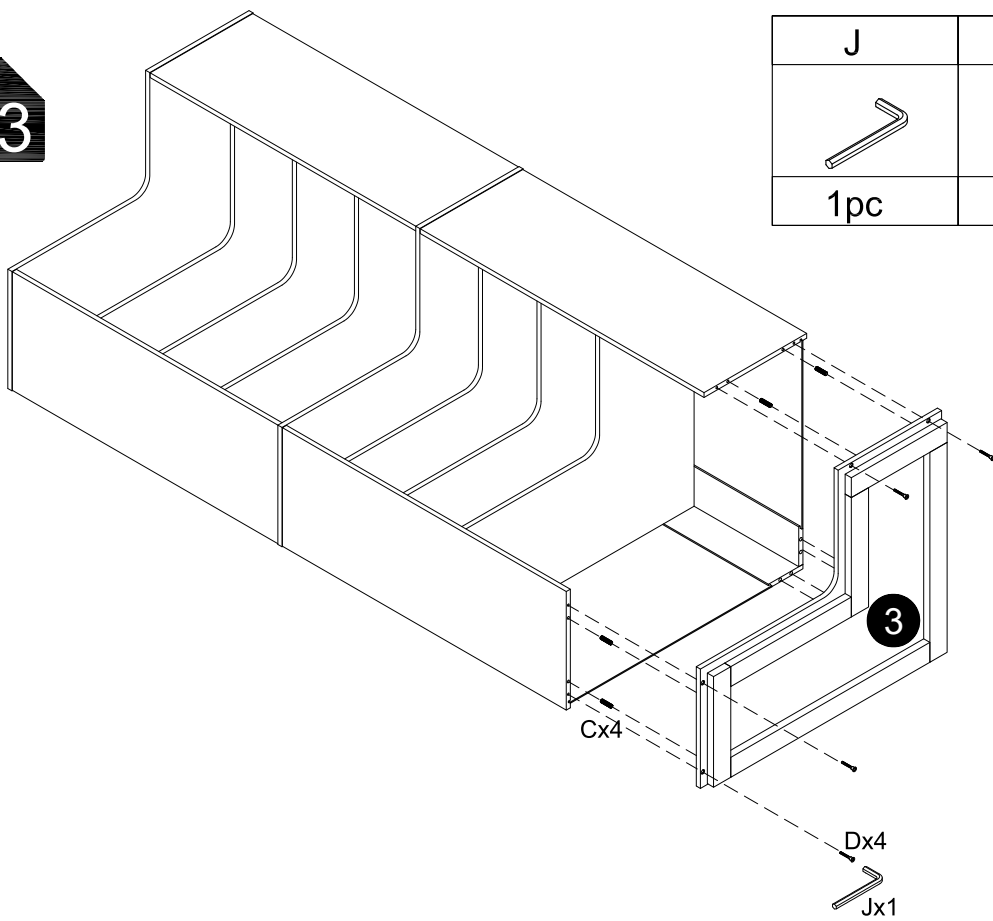

J	C	D
1pc	Ø6x30mm 4 pcs	Ø5x40mm 4 pcs



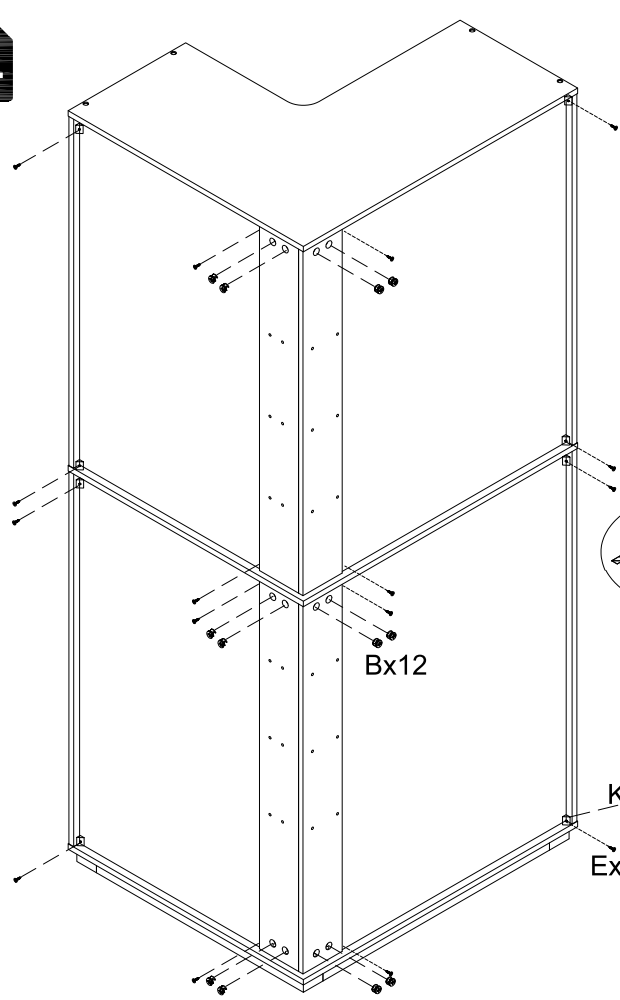

14

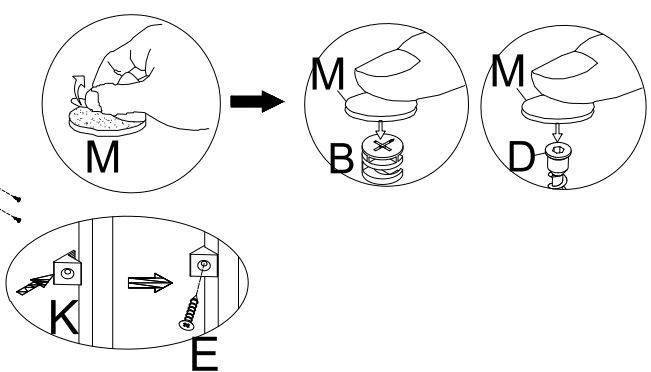

B	E	K	M
Ø15x10mm 12 pcs	Ø3.5x14mm 16 pcs	16 pcs	48 pcs



15

E	H	I	L
 Ø3.5x14mm			 Ø4x40mm
2 pcs	2 pcs	2 pcs	2 pcs

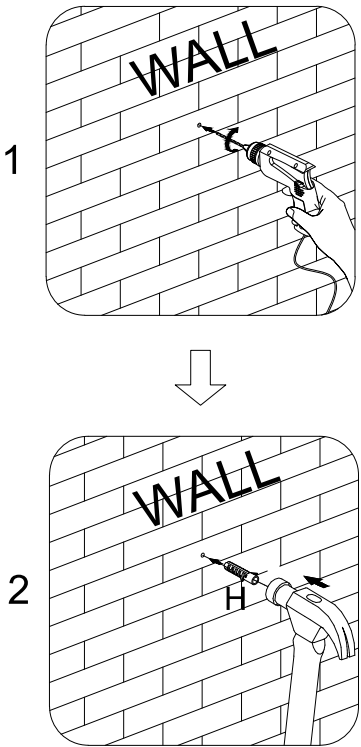
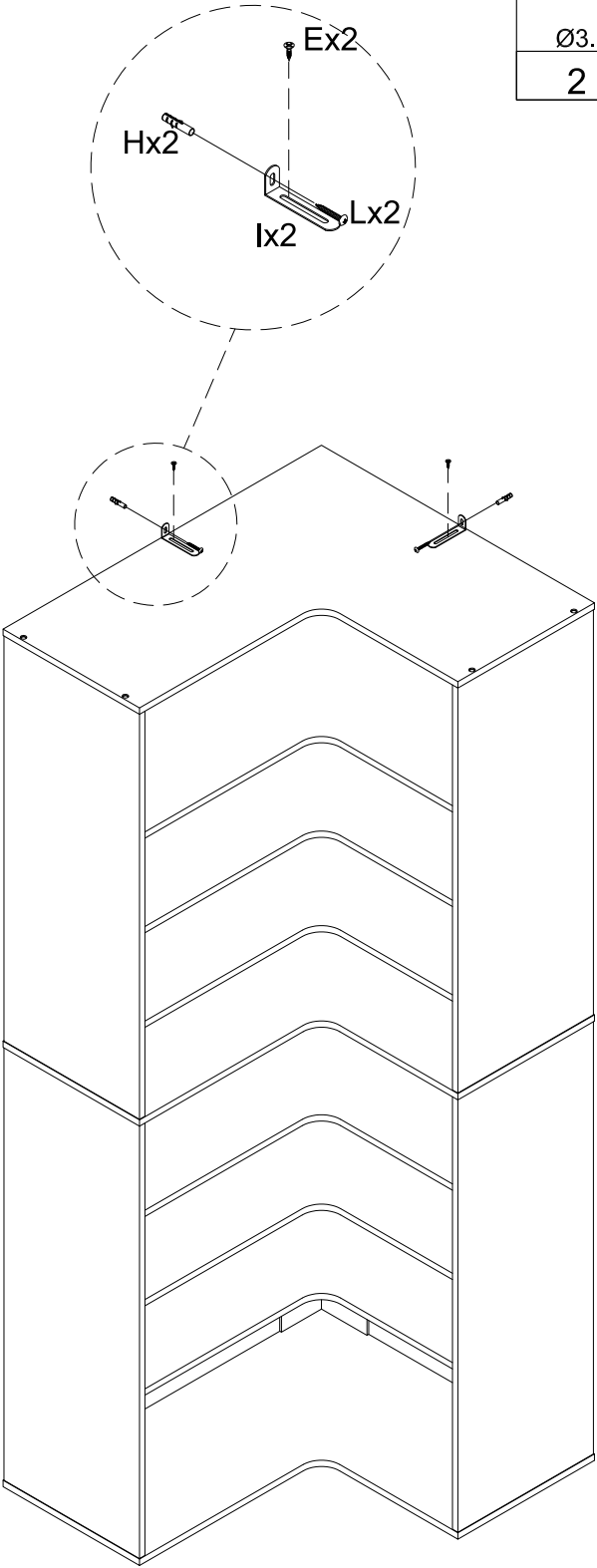

Thank you for your support!

