

King Assembly Instructions

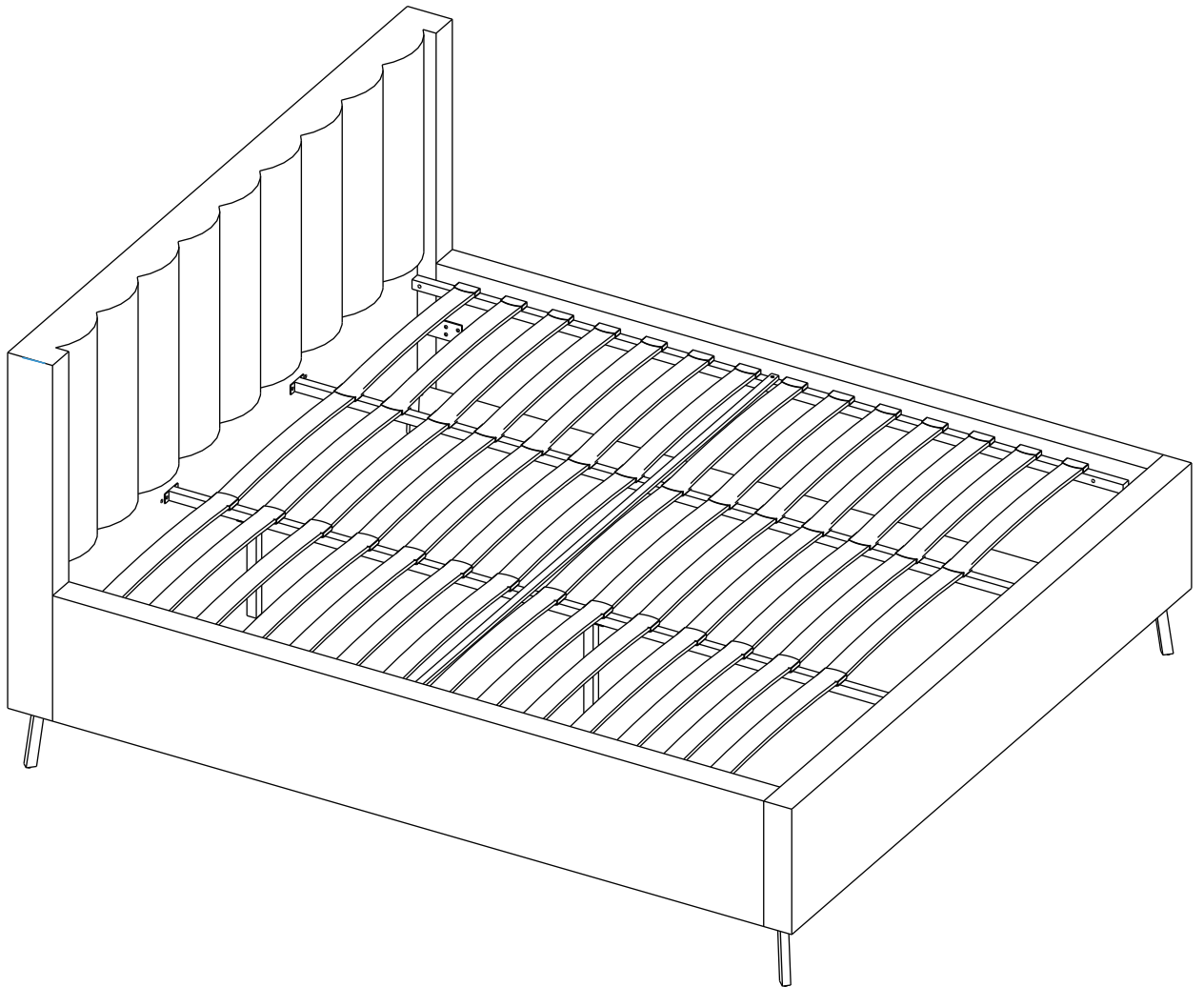

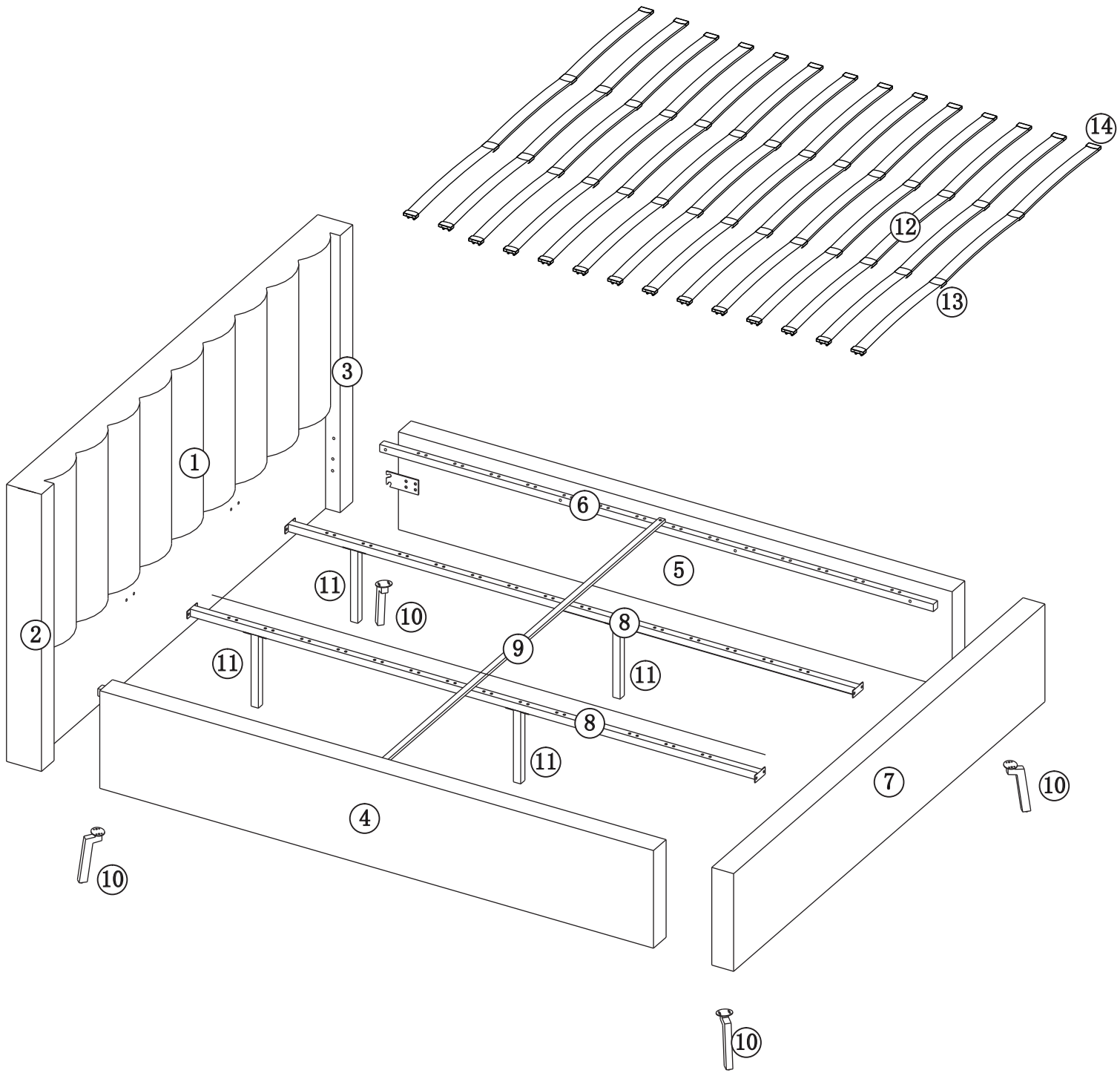







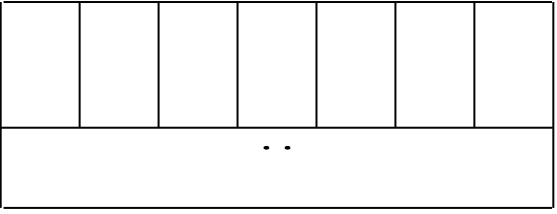
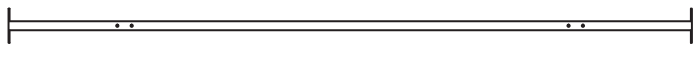
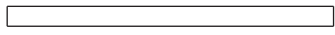

CONGRATULATIONS ON YOUR NEW BED PURCHASE

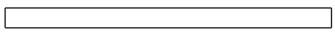
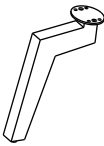
~Warning: do not move bed after final assembly as it may result in damages to floor and /or bed~









CONGRATULATIONS ON YOUR NEW BED PURCHASE

~Warning: do not move bed after final assembly as it may result in damages to floor and /or bed~

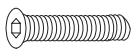
<p>①</p>  <p>1950x1210x105mm 1 PC</p>	<p>⑧</p>  <p>2080x80x25mm 2 PCS</p>
<p>②</p>  <p>1210x200x60mm 1 PC</p>	<p>⑨</p>  <p>1948x20x10mm 1 PC</p>
<p>③</p>  <p>1210x200x60mm 1 PC</p>	<p>⑩</p>  <p>4 PCS</p>
<p>④</p>  <p>1980x300x50mm 1 PC</p>	<p>⑪</p>  <p>334x80x25mm 4 PCS</p>
<p>⑤</p>  <p>1980x300x50mm 1 PC</p>	<p>⑫</p>  <p>649x53x9mm 42 PCS</p>
<p>⑥</p>  <p>1900x25x25mm 2 PCS</p>	<p>⑬</p>  <p>28 PCS</p>
<p>⑦</p>  <p>2050x300x60mm 1 PC</p>	<p>⑭</p>  <p>28 PCS</p>

CONGRATULATIONS ON YOUR NEW BED PURCHASE

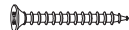
~Warning: do not move bed after final assembly as it may result in damages to floor and /or bed~

(A)  M8 x 20mm 16 PCS	(B)  M6 x 20mm 18 PCS	(C)  M6 x 35mm 14 PCS
(D)  M4 1 PC	(E)  M5 1 PC	(F)  M5 x 25mm 8 PCS
(G)  2 PCS	(I)  30 PCS	

STEP 1: Put (2), (3), (7) upward, tighten 50% with I and A by using Allen Key E.

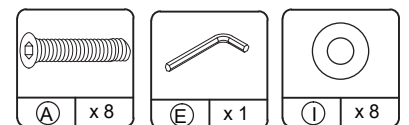
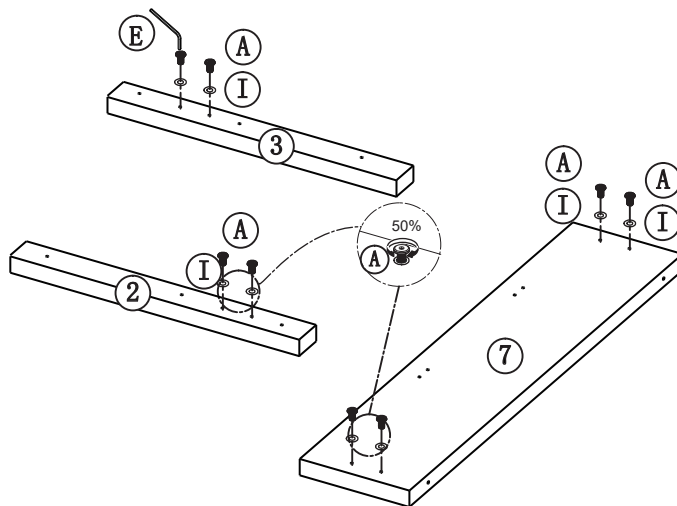

CONGRATULATIONS ON YOUR NEW BED PURCHASE

~Warning: do not move bed after final assembly as it may result in damages to floor and /or bed~

STEP 2: Put ⑧ upward, tighten ⑪ with B by using Allen Key D.

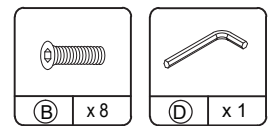
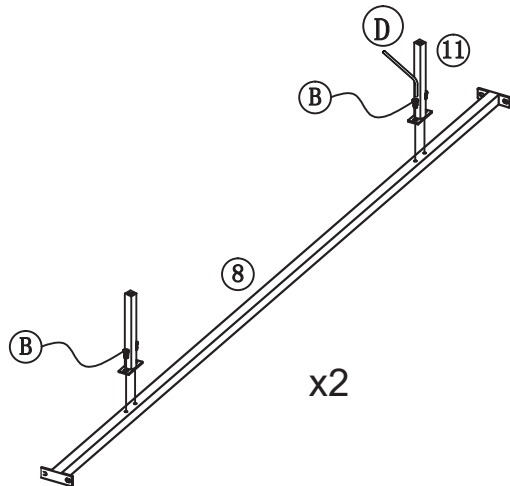

STEP 3: Attach headboard ① with ② and ③, firstly, put headboard straight. Open the Velcro part in the back of the headboard, put ② and ③ into the position as shown on illustration. Tighten with I and C by using allen key D.

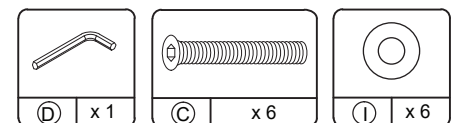
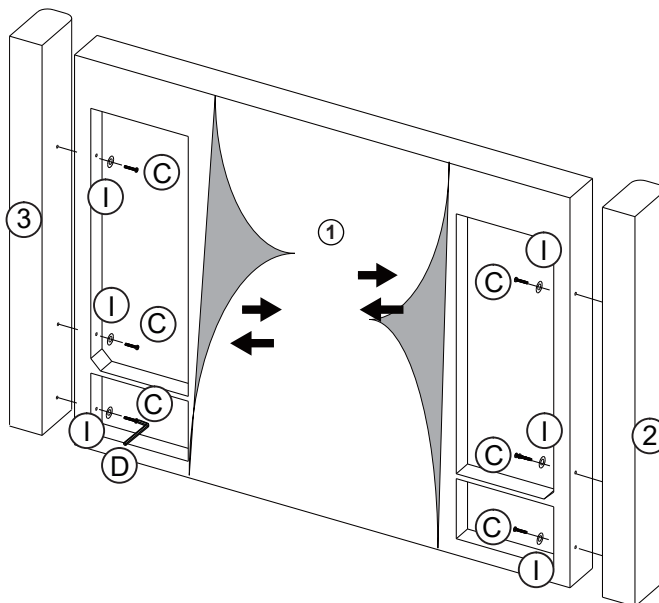

CONGRATULATIONS ON YOUR NEW BED PURCHASE

~Warning: do not move bed after final assembly as it may result in damages to floor and /or bed~

STEP 4: Attach sideboards (4), (5) to the headboard (1), tighten with I & A by using allen key E, then attach (7) to (4) & (5), tighten with I & A by using allen key E.

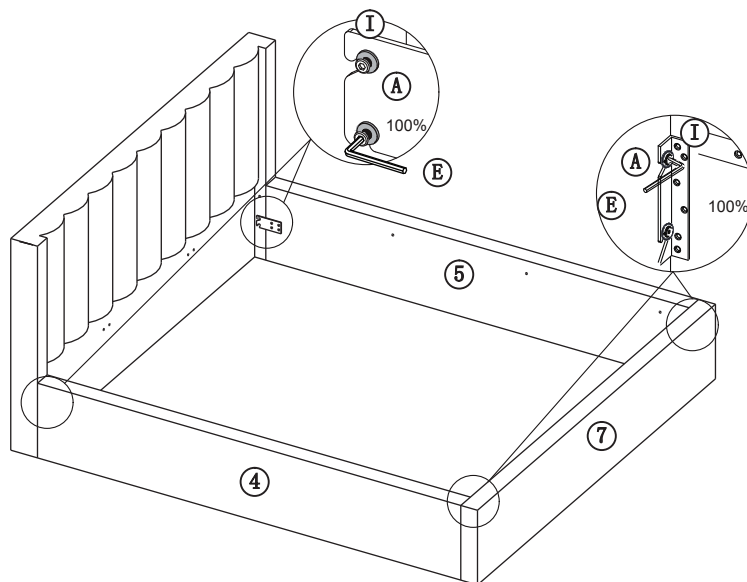

STEP 5: Put 2 metal bars on bed frame as per position on illustration, tighten with I/C by using allen key D.

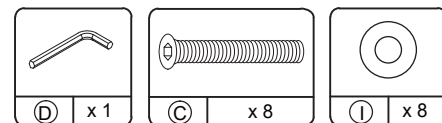
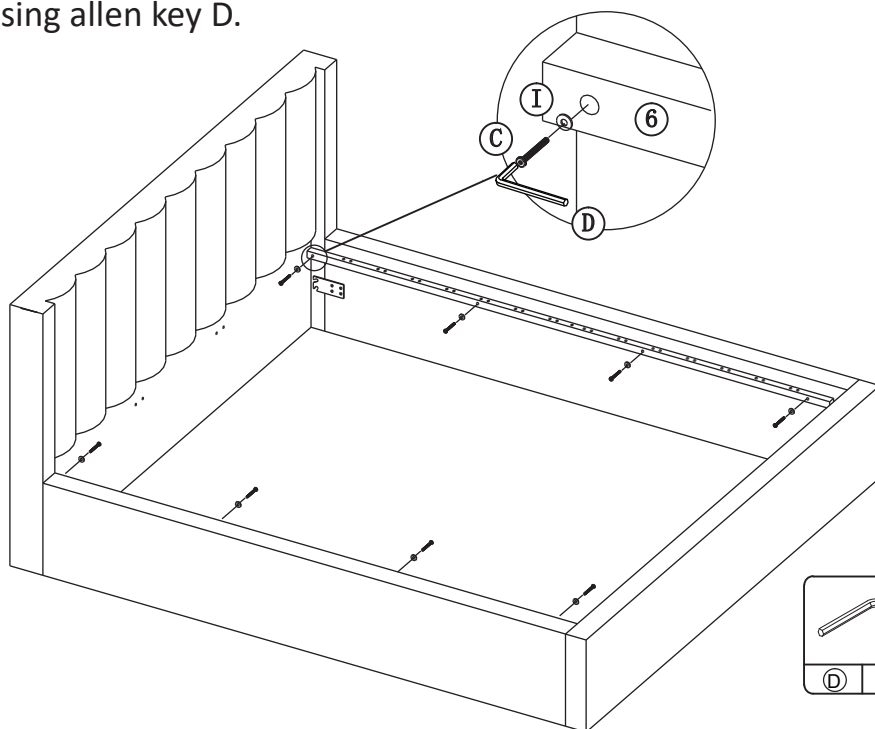

CONGRATULATIONS ON YOUR NEW BED PURCHASE

~Warning: do not move bed after final assembly as it may result in damages to floor and /or bed~

STEP 6: Tighten bed legs ⑩ with I/A by using allen key E, Then put metal pad G as the position on illustration, tighten with F by using drill.

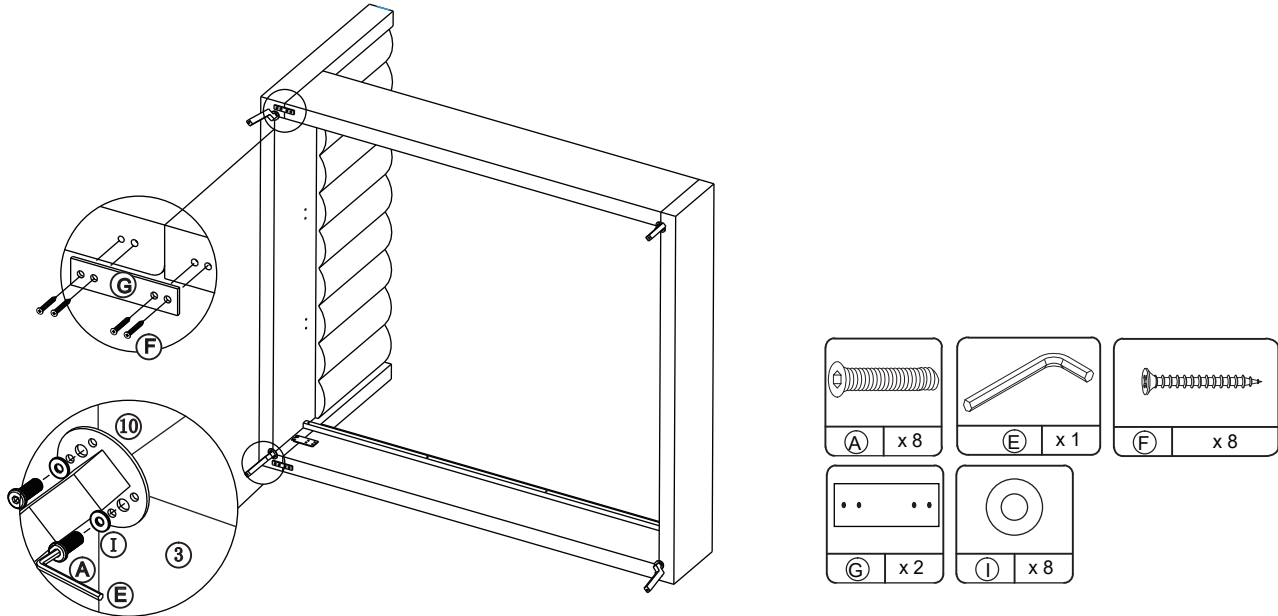

STEP 7: Put 2 middle bars as position on illustration, tighten with B by using Allen Key D.

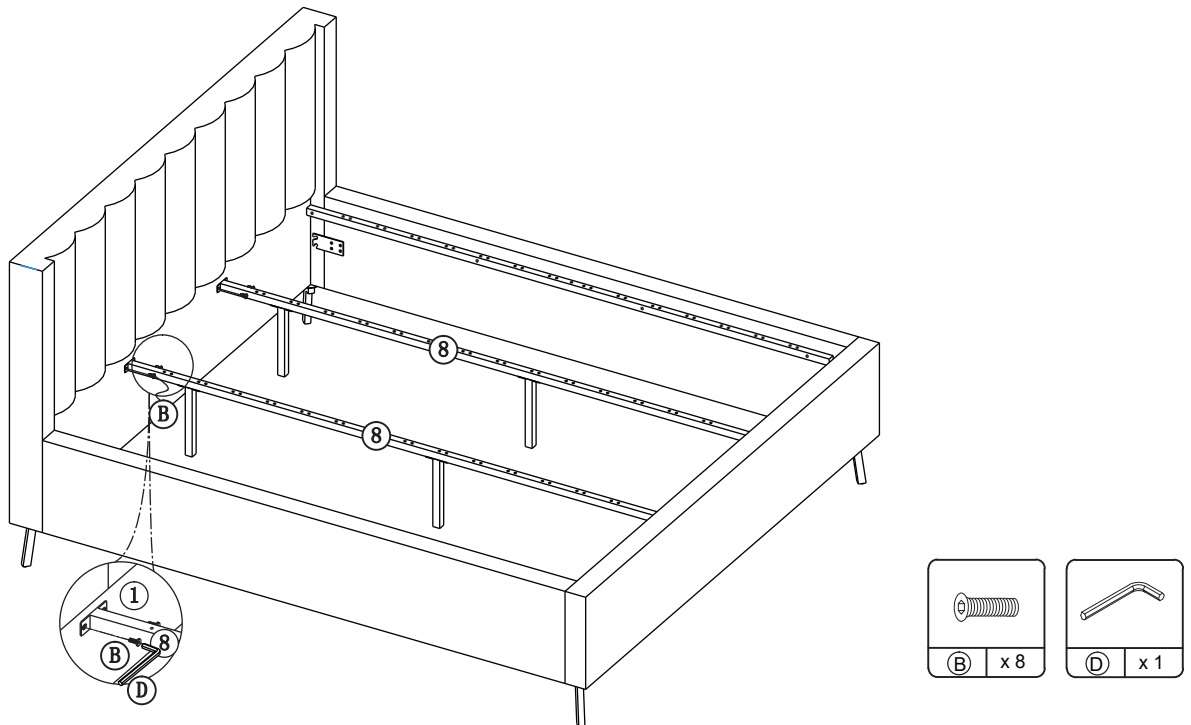

CONGRATULATIONS ON YOUR NEW BED PURCHASE

~Warning: do not move bed after final assembly as it may result in damages to floor and /or bed~

STEP 8: Put middle bar (9) as position shown on illustration, tighten with B by using allen key D.

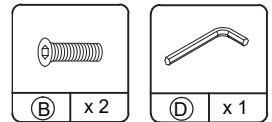
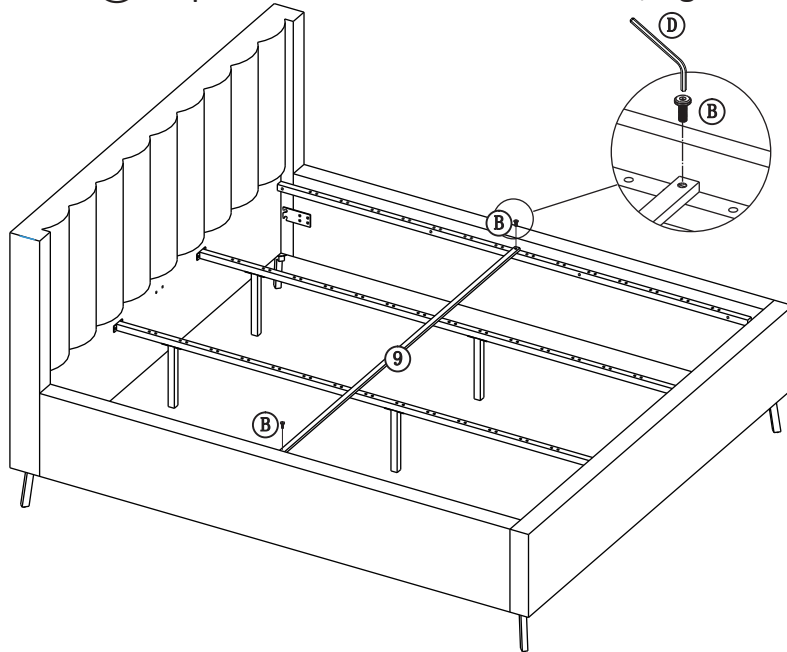

STEP 9: Assemble middle part firstly, Insert (13) at both ends of slat (12), then put slats with curve upward as position showed on illustration, gently press both ends into the metal bar.

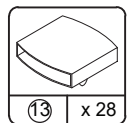
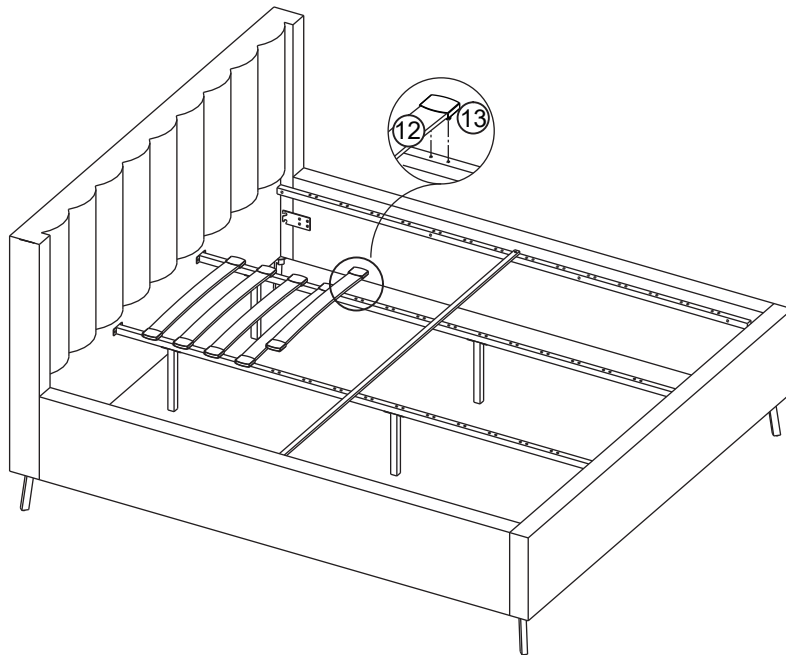

CONGRATULATIONS ON YOUR NEW BED PURCHASE

~Warning: do not move bed after final assembly as it may result in damages to floor and /or bed~

STEP 10: Then assemble both sides. Insert (14) at both ends of slat (12), then put slats with curve upward as position showed on illustration, gently press both ends into the metal bar.

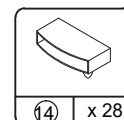
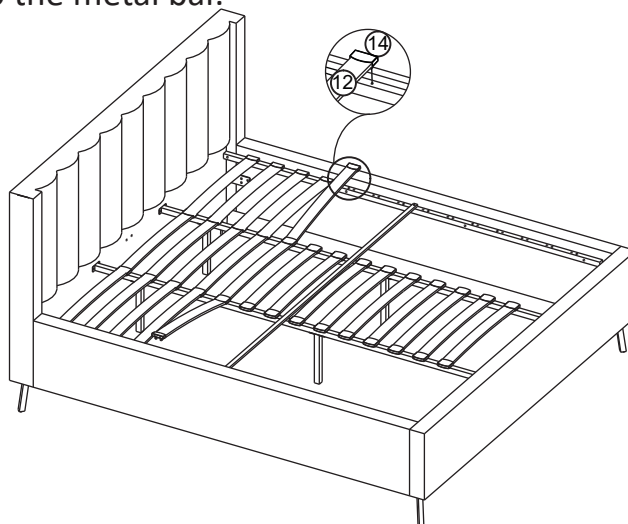

STEP 11:

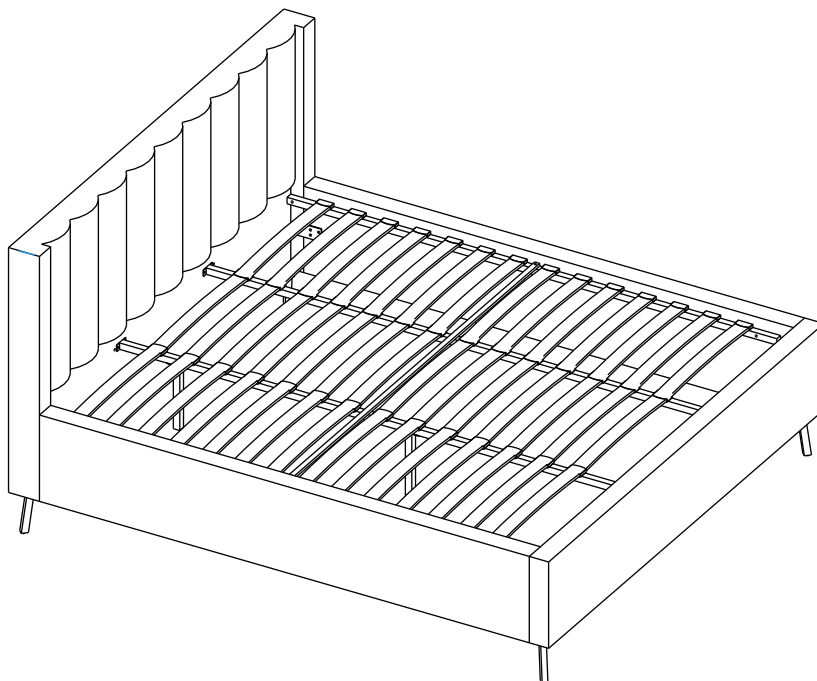

CONGRATULATIONS ON YOUR NEW BED PURCHASE

~Warning: do not move bed after final assembly as it may result in damages to floor and /or bed~