



ASSEMBLY INSTRUCTIONS



Item No : D3434-20
KODY UPHOLSTERED DINING CHAIR
(2PCS PER CARTON)

Thank you for purchasing this quality product. Be sure to check all packing materials carefully for small parts, which may have come loose inside the carton during shipment. Identify and count all items and compare with the parts list and/or hardware list shown below.

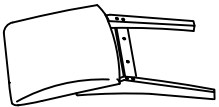
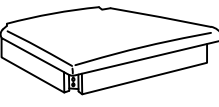
Cautions :

- (1) Do not fully-tighten the nut or nut bolts initially until all nuts or bolt is ready assembled.
 (To avoid causing damages to the thread, do not over-tighten the nuts or bolts.)
- (2) Keep all hardware part out of reach of children.

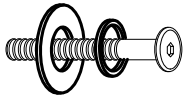
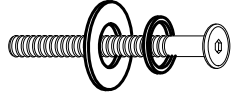
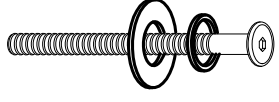
PARTS LIST			
NO	DESCRIPTION	SKETCH	QTY
A	CHAIR BACK		2 PCS
B	SEAT FRAME WITH CUSHION		2 PCS
C	FRONT LEG		4 PCS

HARDWARE LIST			
NO	DESCRIPTION	SKETCH	QTY
1	SHORT BOLT 1/4" X 1 5/8" WITH LOCK WASHER & WASHER		4 PCS
2	MEDIUM BOLT 1/4" X 2 3/8" WITH LOCK WASHER & WASHER		8 PCS
3	LONG BOLT 1/4" X 3 3/16" WITH LOCK WASHER & WASHER		8 PCS
4	ALLEN KEY		1 PC

WEIGHT CAPACITY	250 pounds (per seat)
-----------------	-----------------------

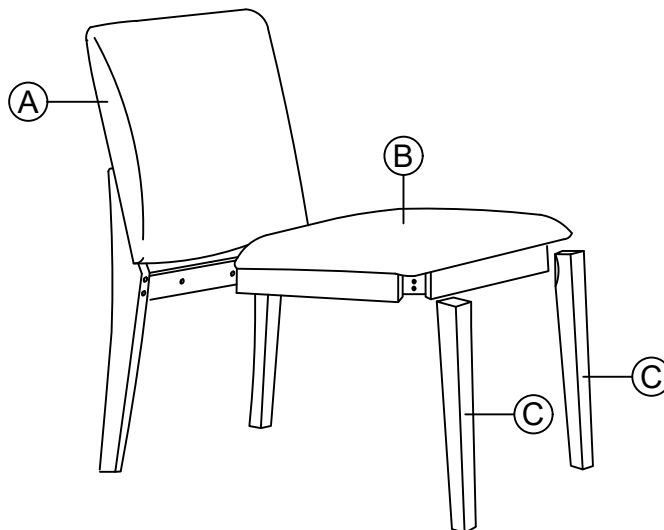
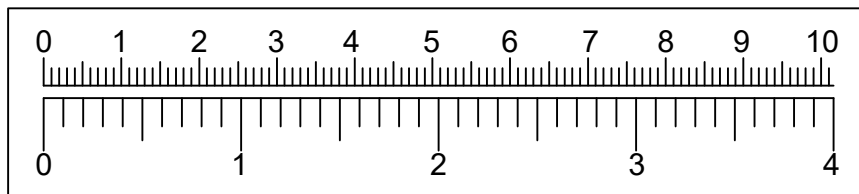

STEP 1 : Assemble the seat frame with cushion (B) with the chair back (A) using the Allen Key (4) with hardware (1).

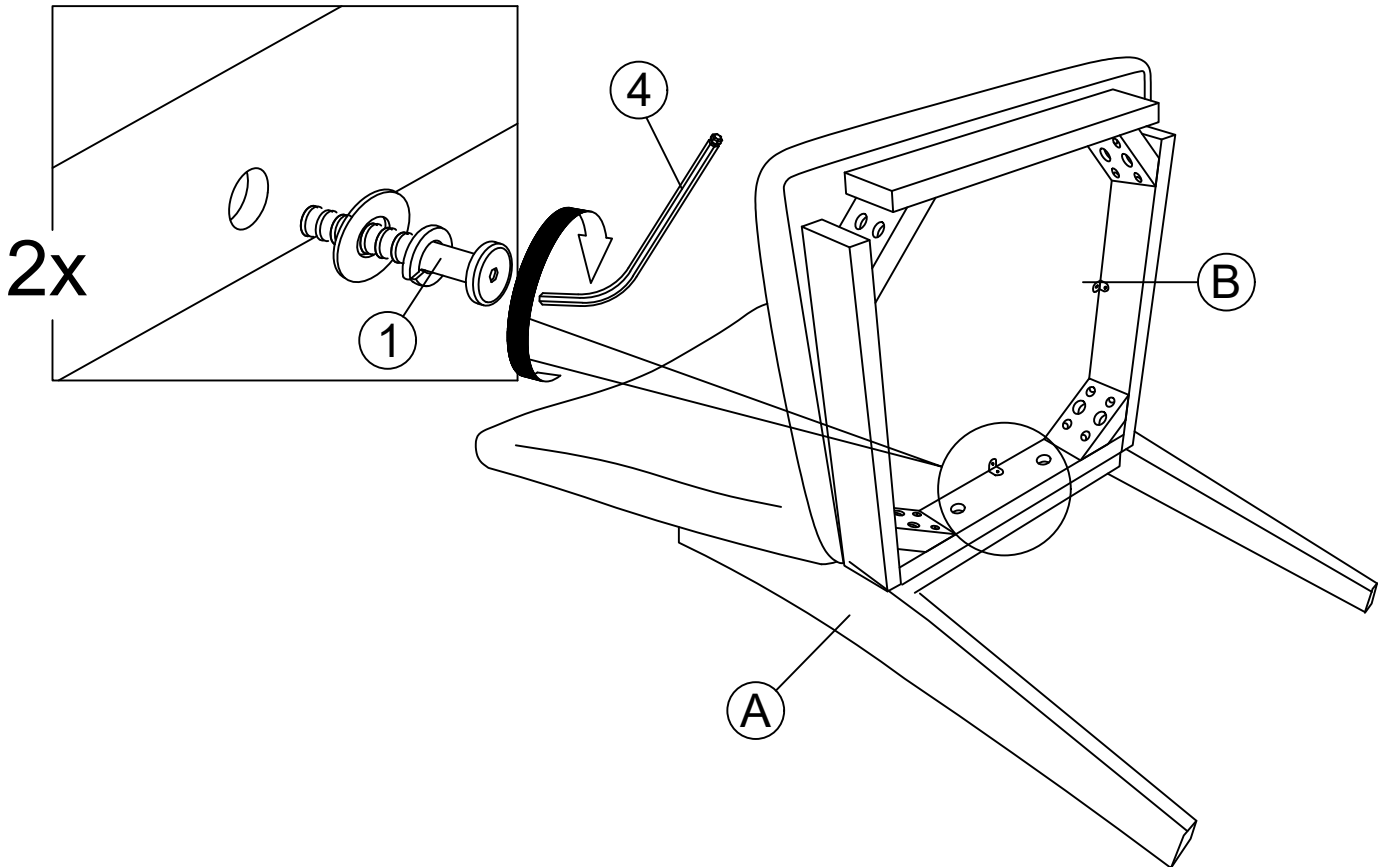

STEP 2 : Attach the seat frame with cushion (B) with the back legs of the chair back (A) by using the Allen Key (4) with hardware (3).
**Attention: DO NOT TIGHTEN THE BOLTS.

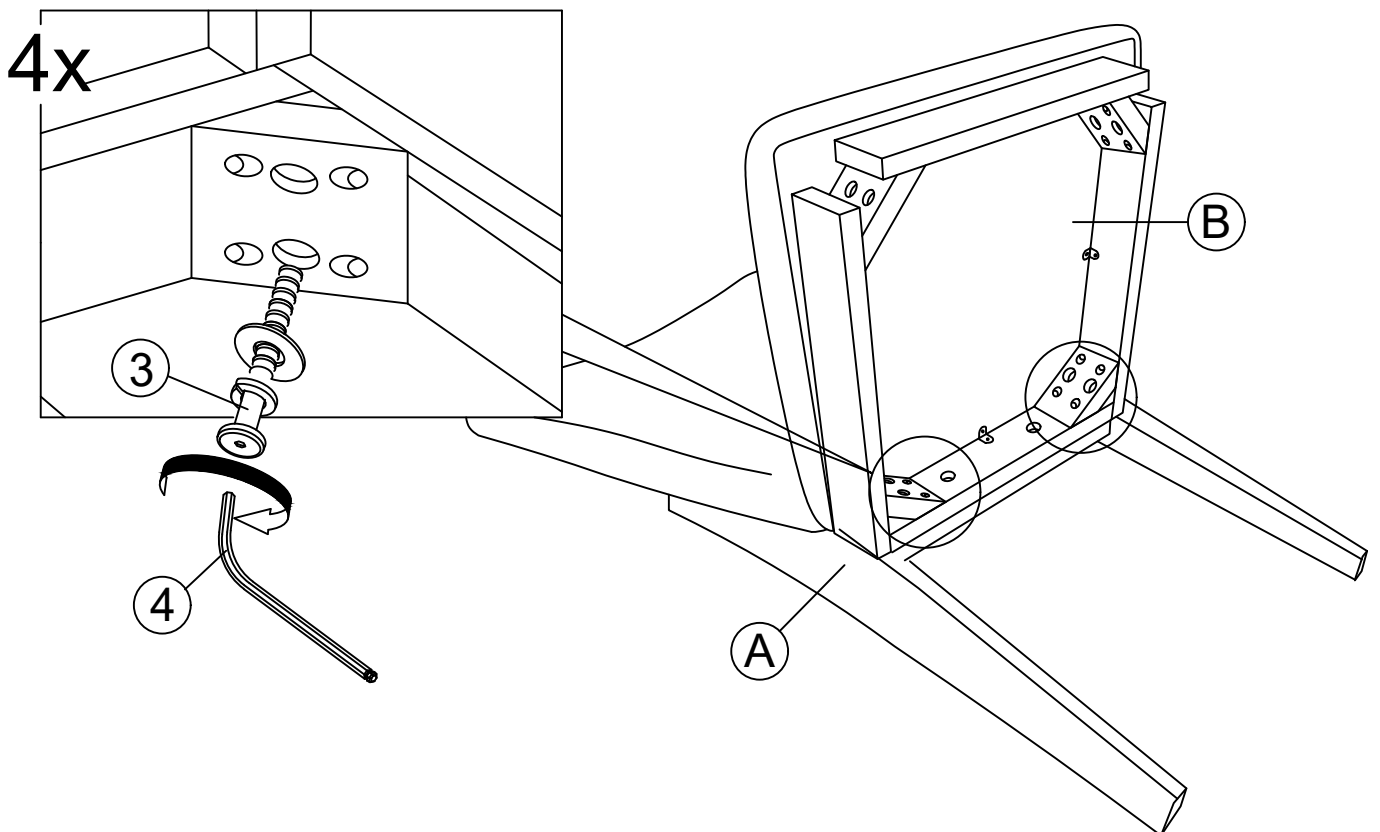

STEP 3 : Assemble the legs (C) with the seat frame with cushion (B) by using Allen key (4) with hardware (2).

**Attention: DO NOT TIGHTEN THE BOLTS.

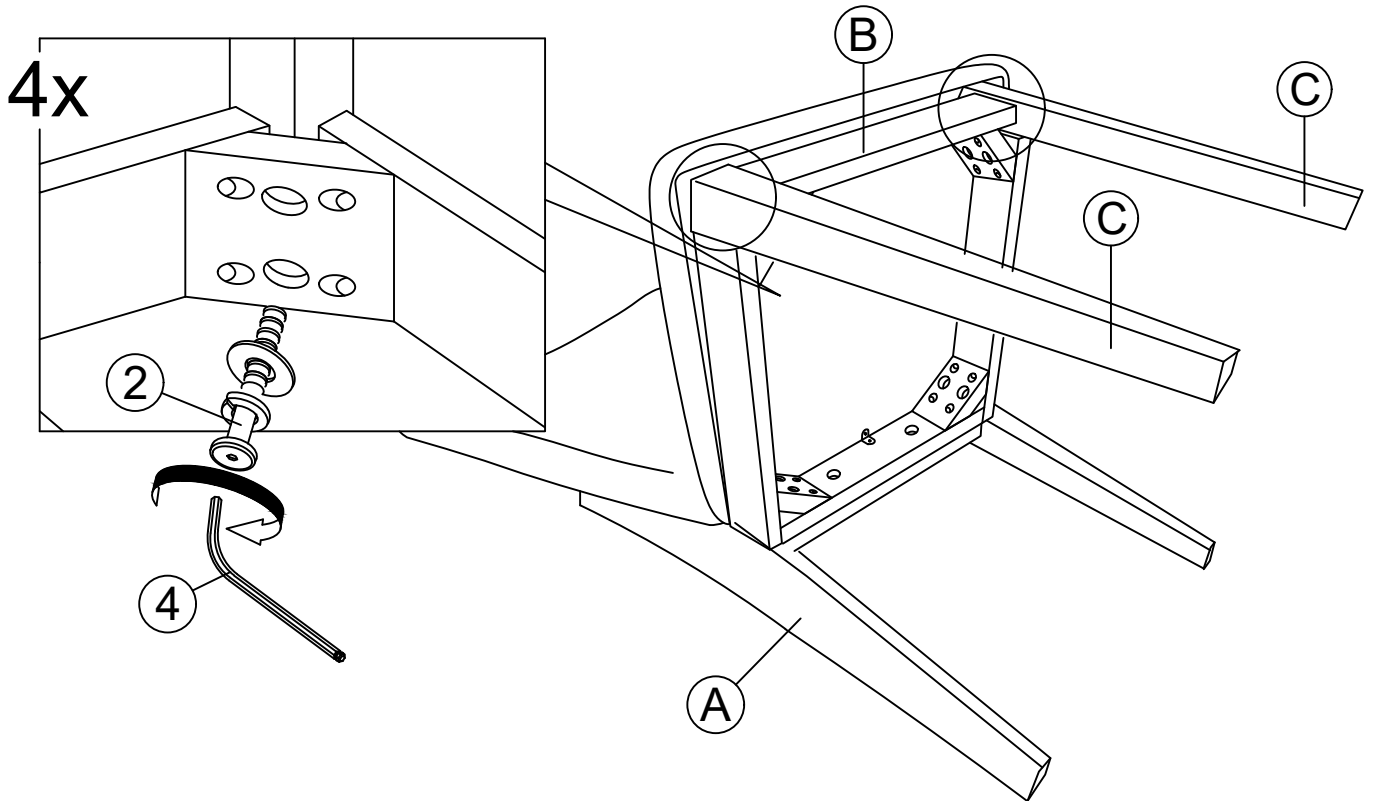

STEP 4 : To level the chair, stand the chair up on a flat surface and tighten all the bolts by using Allen Key (4).

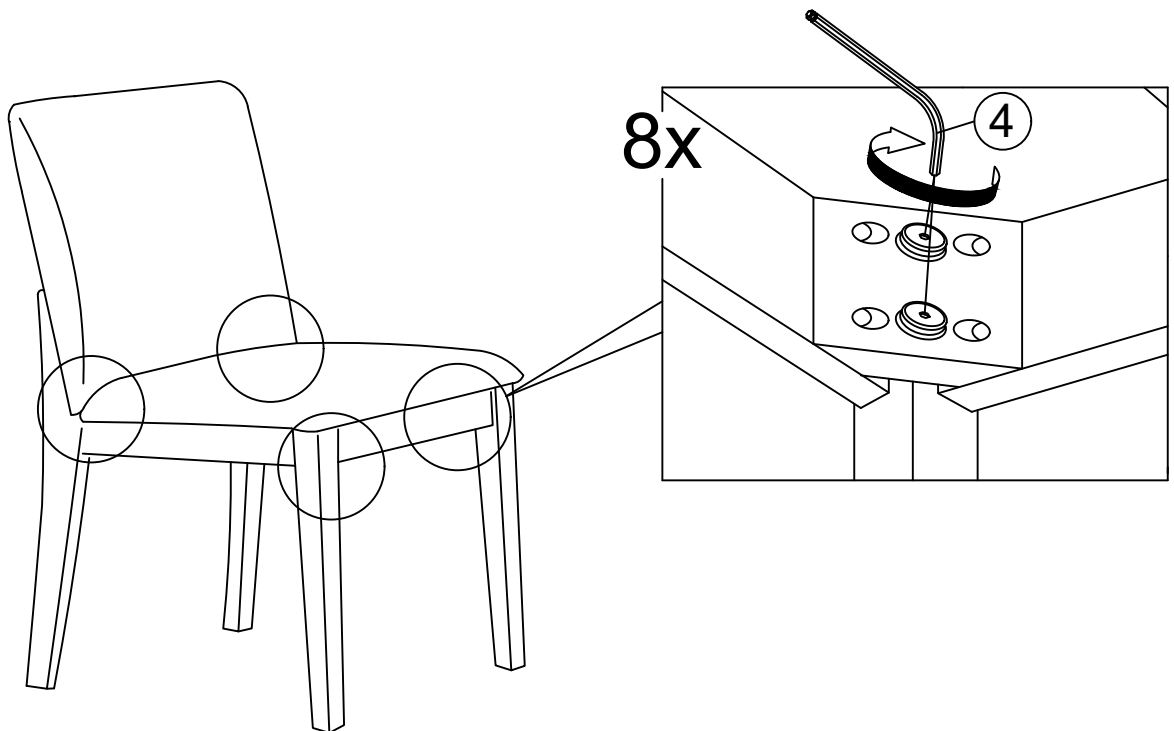

COMPLETED ASSEMBLY.

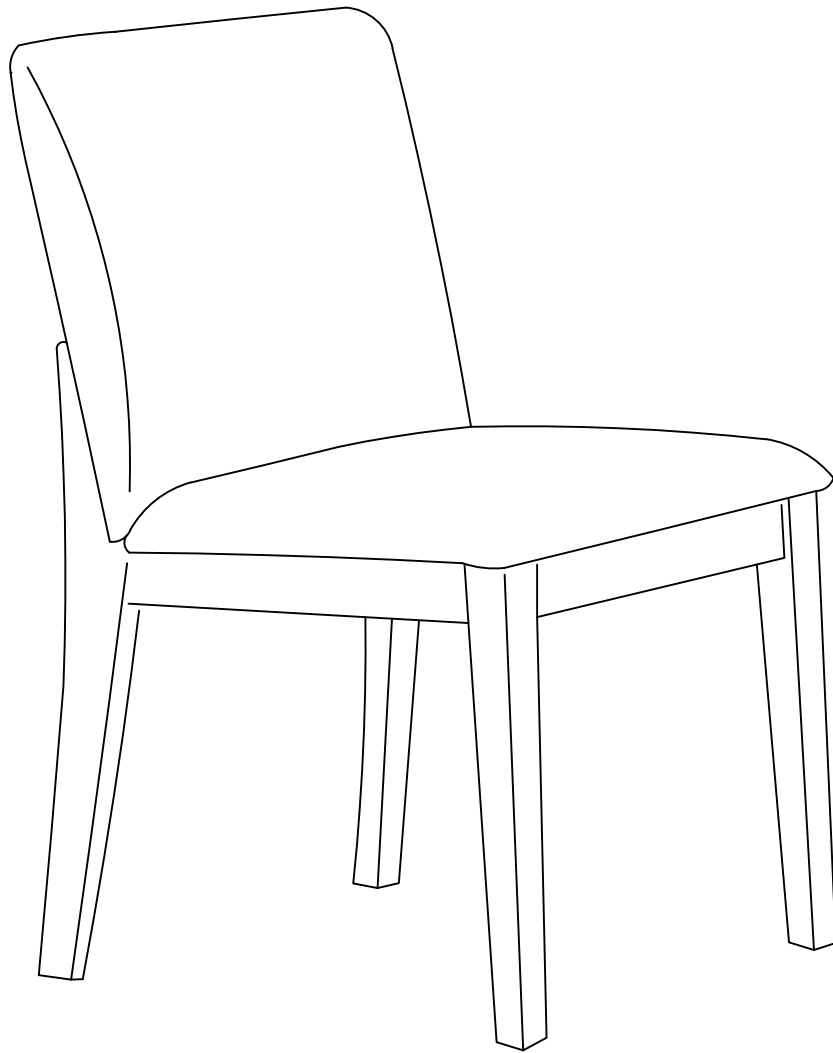



ASSEMBLY INSTRUCTIONS



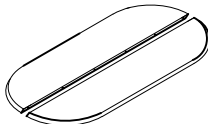
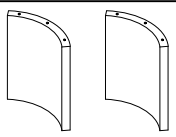
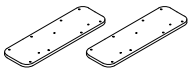

Item No :
D3434-15T KODY 79" OVAL DINING TABLE TOP
D3434-15B KODY OVAL DINING TABLE BASE

Thank you for purchasing this quality product. Be sure to check all packing materials carefully for small parts, which may have come loose inside the carton during shipment. Identify and count all items and compare with the parts list and/or hardware list shown below.

Cautions :

- (1) Do not fully-tighten the nuts or bolts until all nuts and bolts are assembled.
 (To avoid causing damages to the thread, do not over-tighten the nuts or bolts.)
- (2) Keep all hardware part out of reach of children.

PARTS LIST			
NO	DESCRIPTION	SKETCH	QTY
A	TABLE TOP		2 PCS
B	TABLE LEG		2 PCS
C	MOUNTING PLATE		2 PCS
D	SUPPORT BLOCK		4 PCS

HARDWARE LIST			
NO	DESCRIPTION	SKETCH	QTY
1	BOLT 1/4" x 1 5/8"		30 PCS
2	SPRING WASHER 1/4"		30 PCS
3	FLAT WASHER 1/4"		30 PCS
4	ALLEN KEY		1 PC

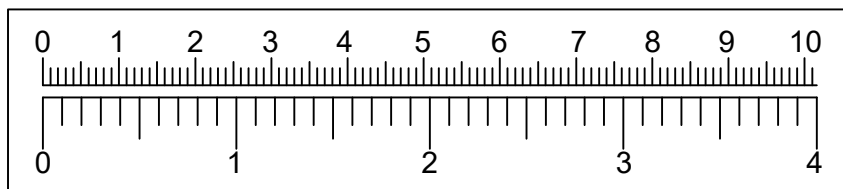

This table design can be assembled with the legs in two ways.

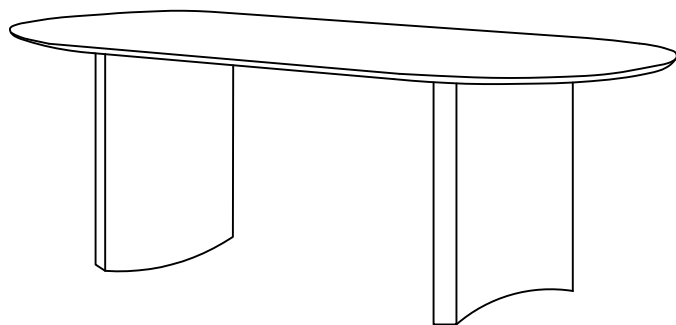

Curve In

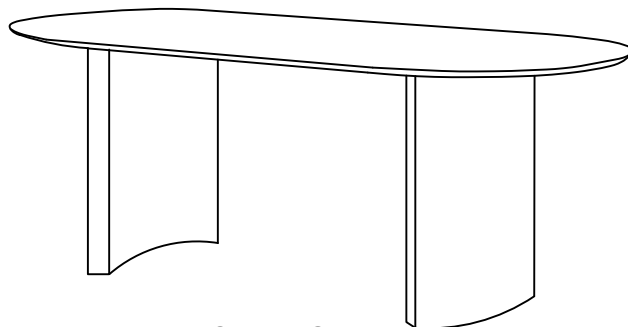

Curve Out

STEP 1 : Place the table top (A) upside down on a flat and clean surface. Attach the table top (A) and close the hinges.

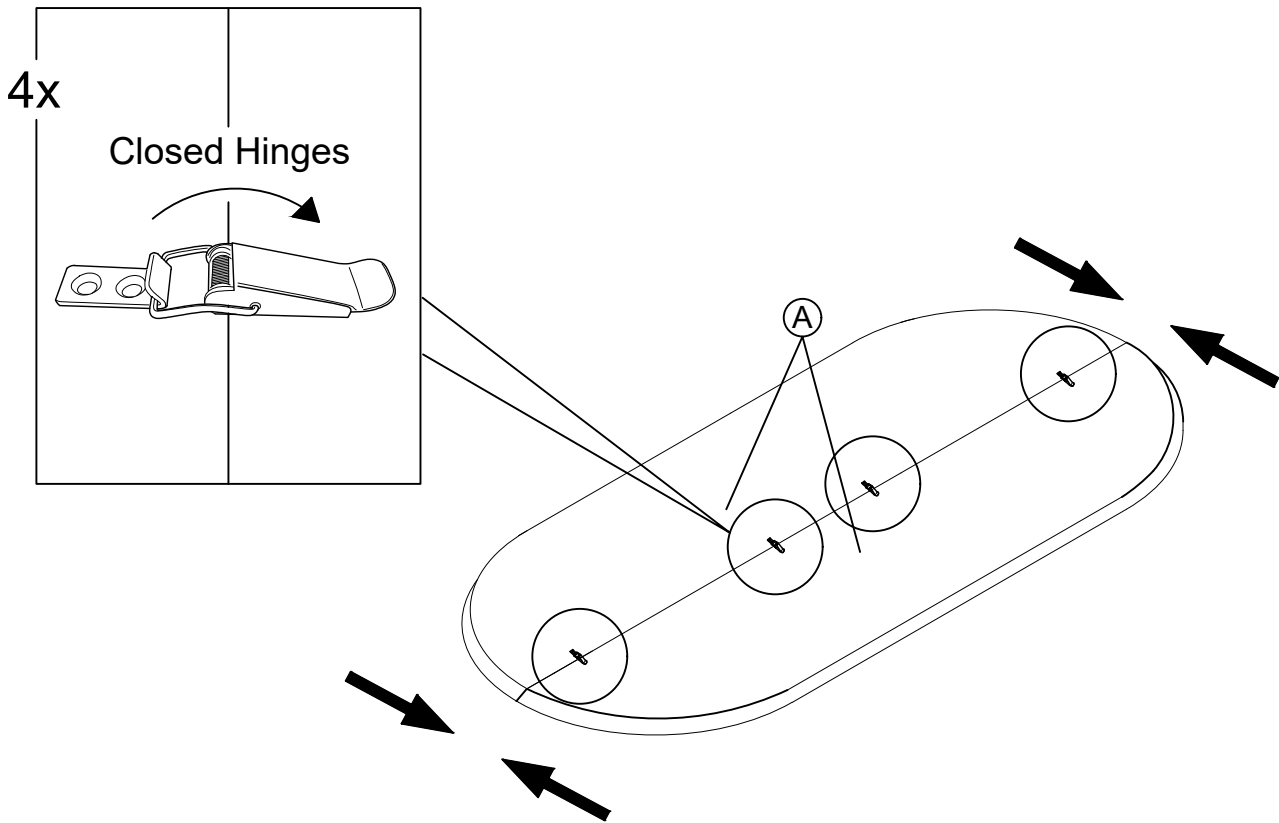

STEP 2 : Assemble the table top (A) with support block (D) by using the Allen Key (4) and the hardware Bolt 1/4" x 1 5/8" (1), Spring washer (2) & Flat washer (3).

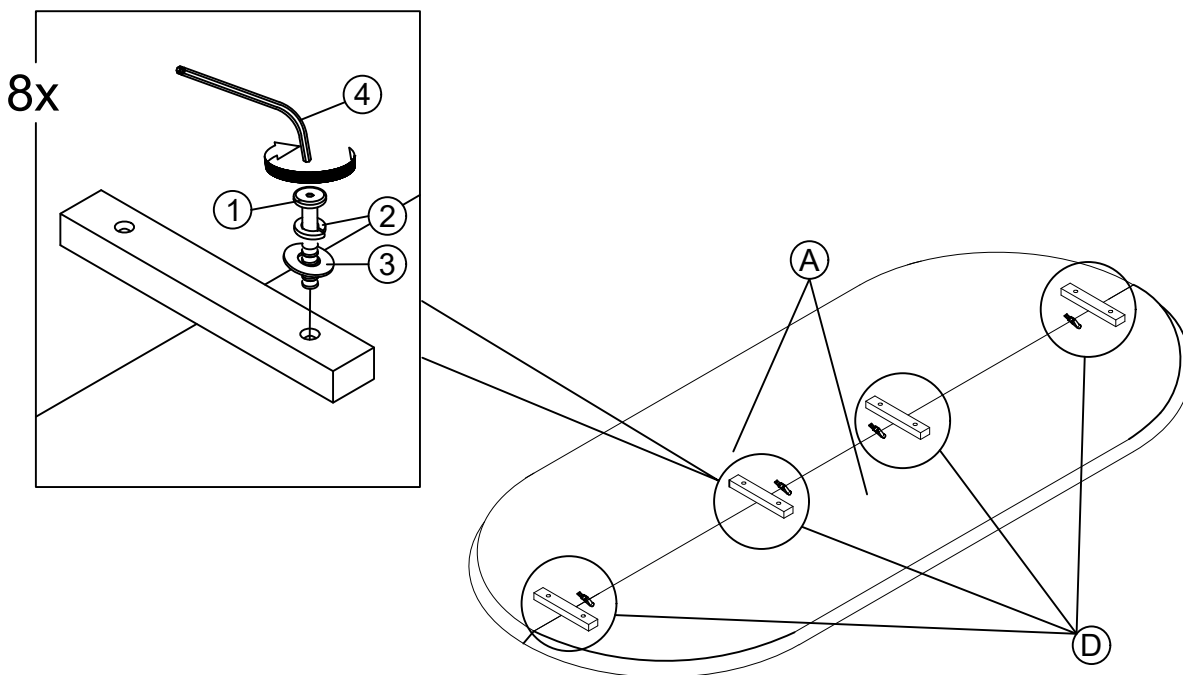

STEP 3 : Assemble the mounting plate (C) to the table leg (B) by using the Allen Key (4) and the hardware Bolt 1/4" x 1 5/8" (1), Spring washer (2) & Flat washer (3).

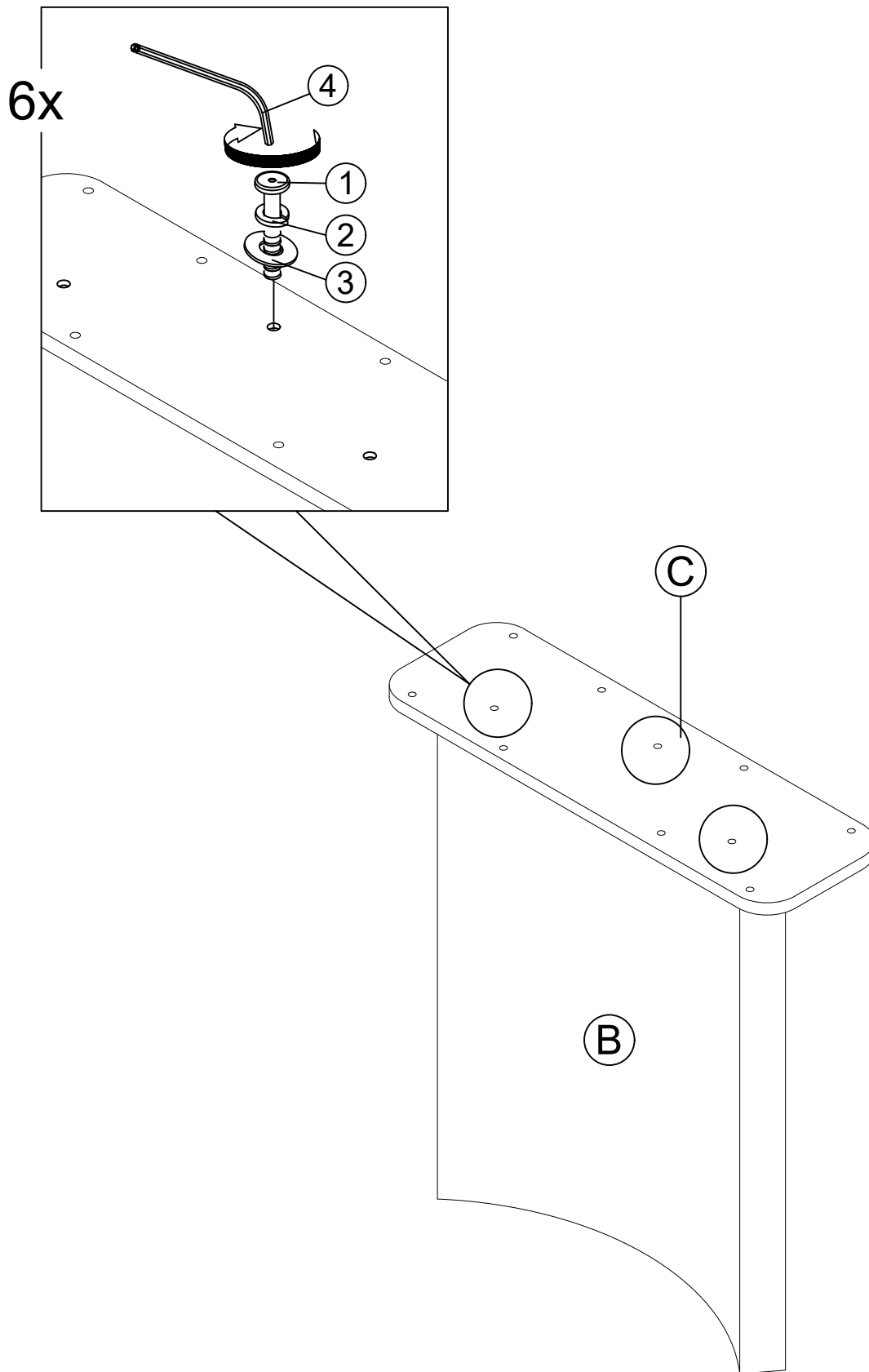

STEP 4 : Assemble the leg frames to the table top (A) by using the Allen Key (4) and the hardware Bolt 1/4" x 1 5/8" (1), Spring washer (2) & Flat washer (3).

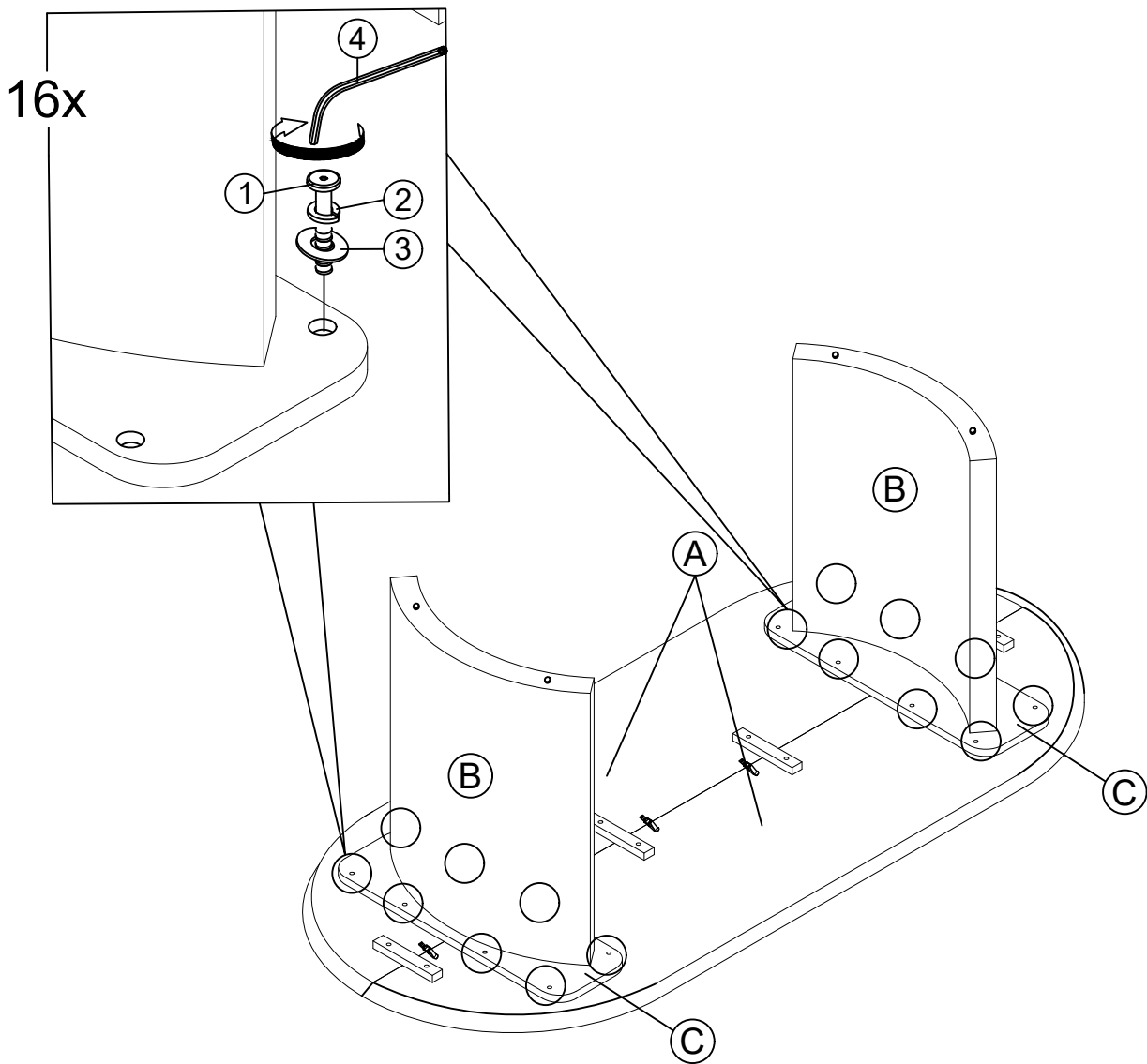

Completed Assembly.

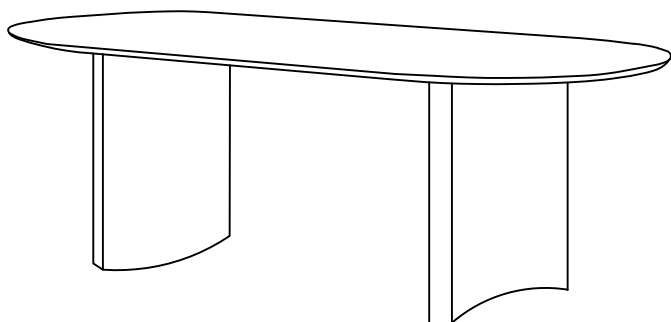

Curve In

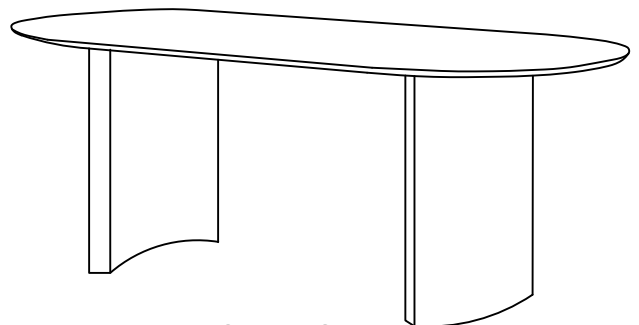

Curve Out