

- | | |
|----------------------------------|------------------------------|
| (D) Montageanleitung | (FR) Notice de montage |
| (NL) Handleiding voor de montage | (CZ) Montážní návod |
| (HU) Szerelési útmutató | (TR) Montaj talimatı |
| (GB) Assembly instructions | (IT) Istruzioni di montaggio |
| (PL) Instrukcja montażu | (SK) Návod na montáž |
| (RO) Instrucțiuni de montaj | (RU) Инструкция по монтажу |

**Service • Assistenza • Dienstverlening • Serwis
Servis • Szerviz • Сервисная служба**

Name • Nom • Nome • Naam •
Nazwa • Jméno • Název • Név •
Denumire • İsim • Название

Nr. • No. • N° • Номер • Č • Sz

Тур • Type • Тір • Tipus • Тиро •
Тип

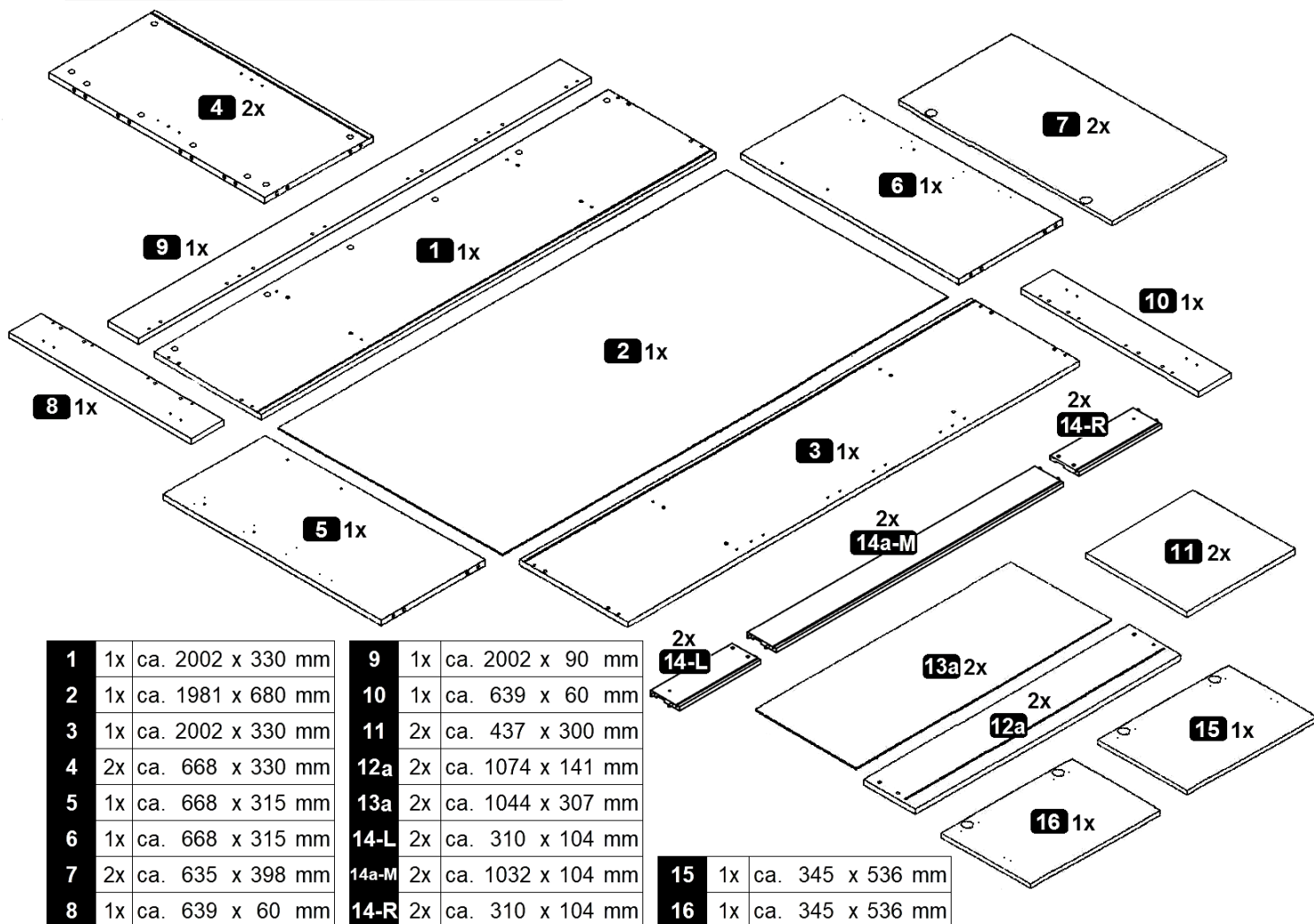
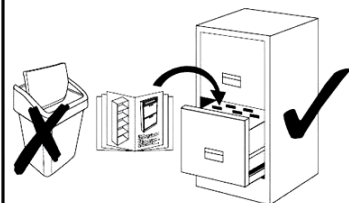
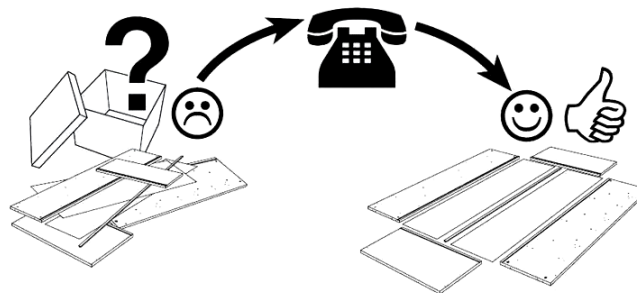

A	8,0 x 30 mm	B	30x	C	30x	D	8x	E	3,0 x 12 mm	F	8x	G	4x h=2
H	4x Ø26	I	9x	J	4,0 x 20 mm	K	2,7 x 20 mm	L	4x 27 x 310 mm	M	8x 6,3 x 13 mm		
N	M4,0 x 9 mm	O	1x	P	12x	Q	4x Ø35	R	2x 250 mm	S	12x 3,5 x 13 mm		



1

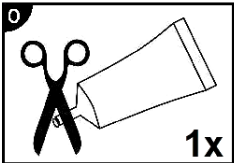
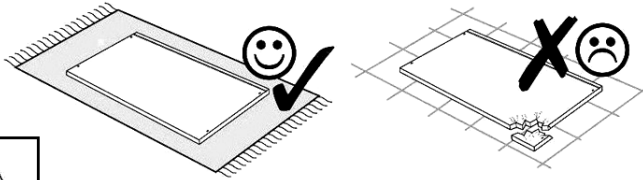

- D Leim
- GB Glue
- FR Colle
- IT Colla
- NL Lijm
- PL Klej
- CZ Lepidlo
- SK Glej
- HU Enyv
- RO Adeziv
- TR Tutkal
- RU Клей

2x

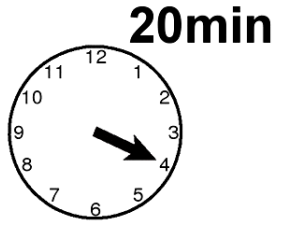
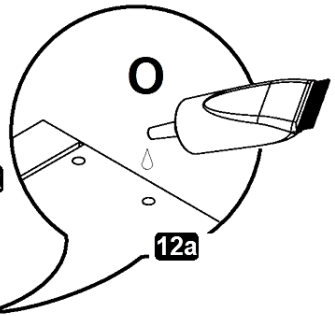
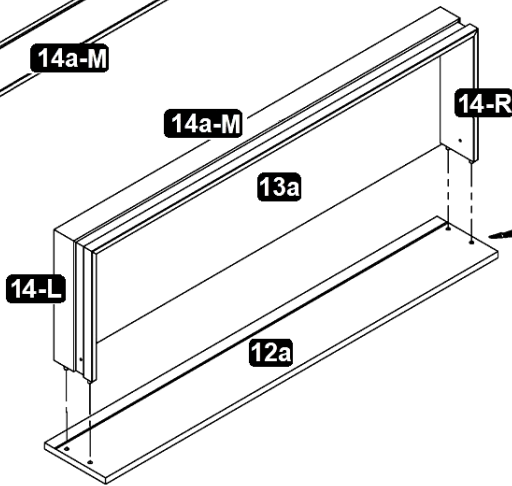
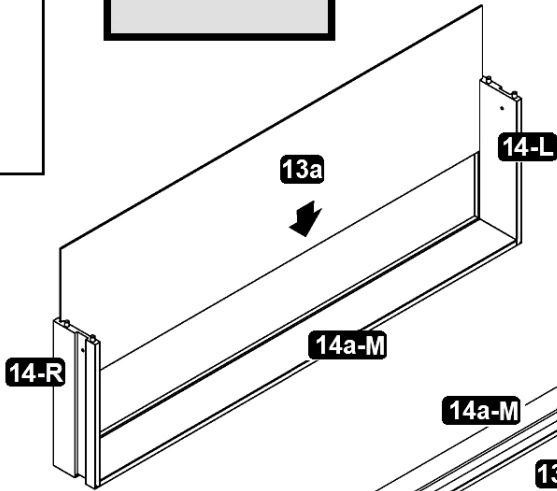
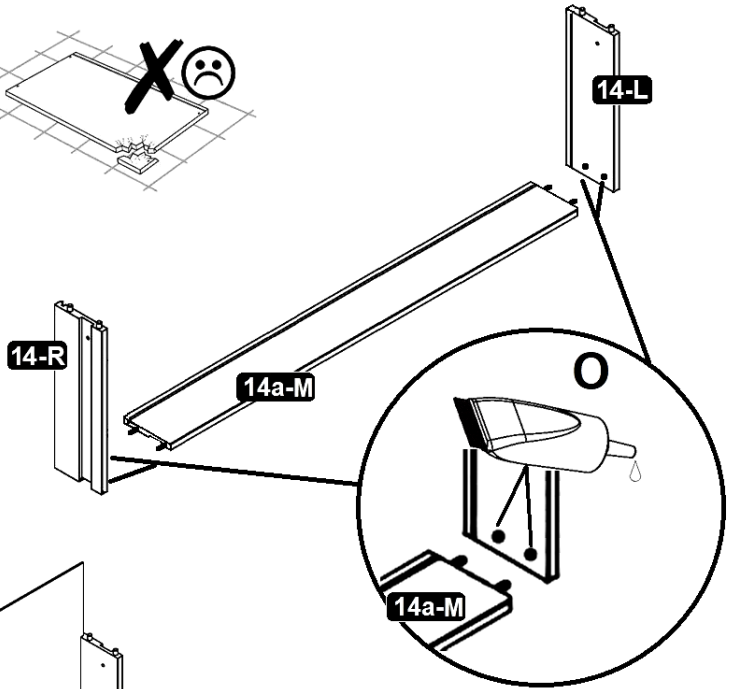



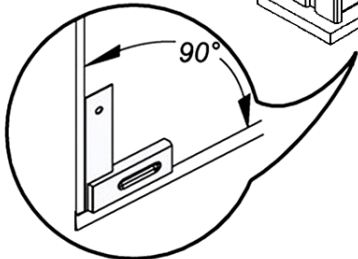
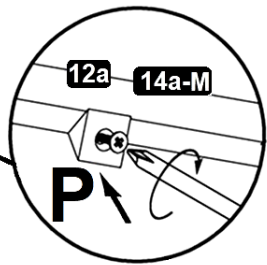
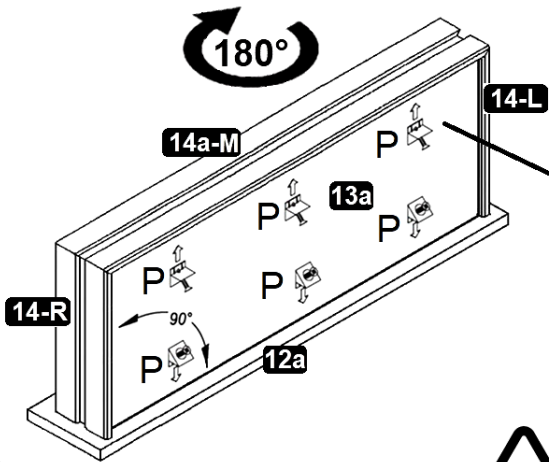
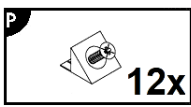

2

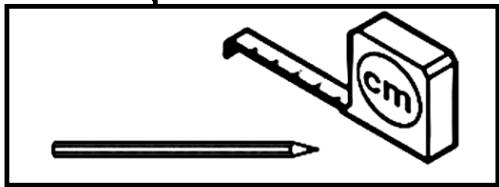
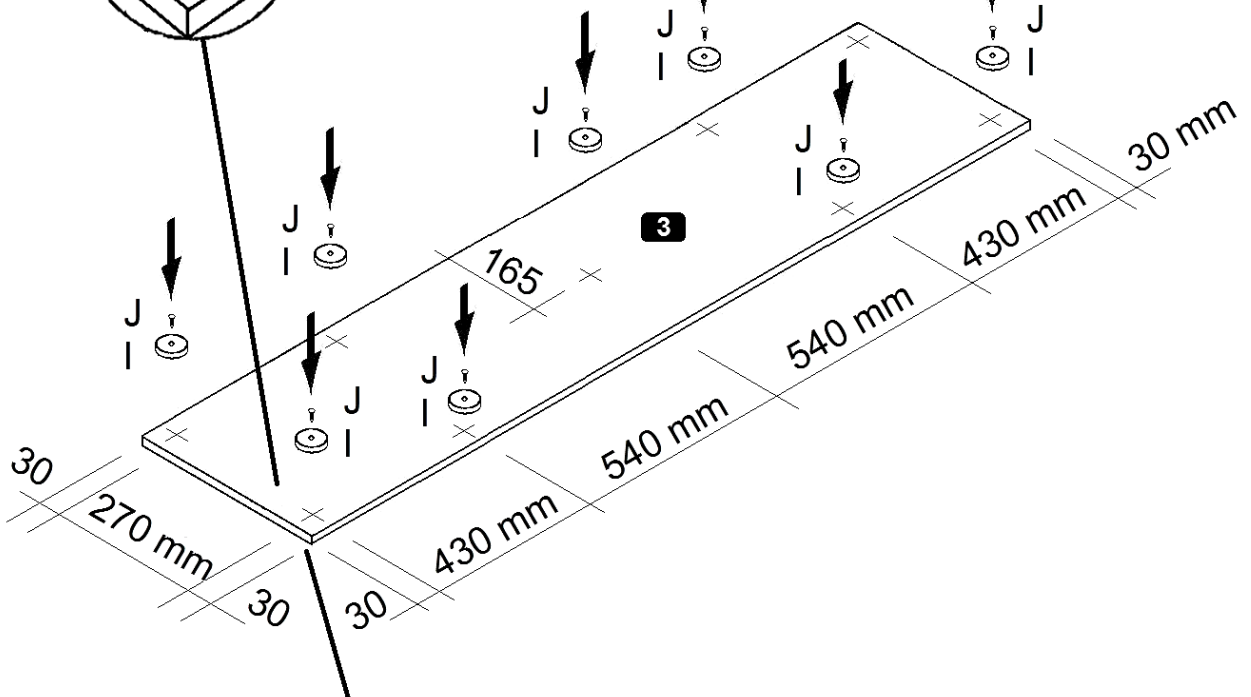
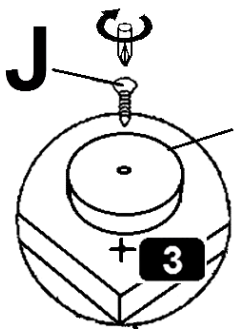
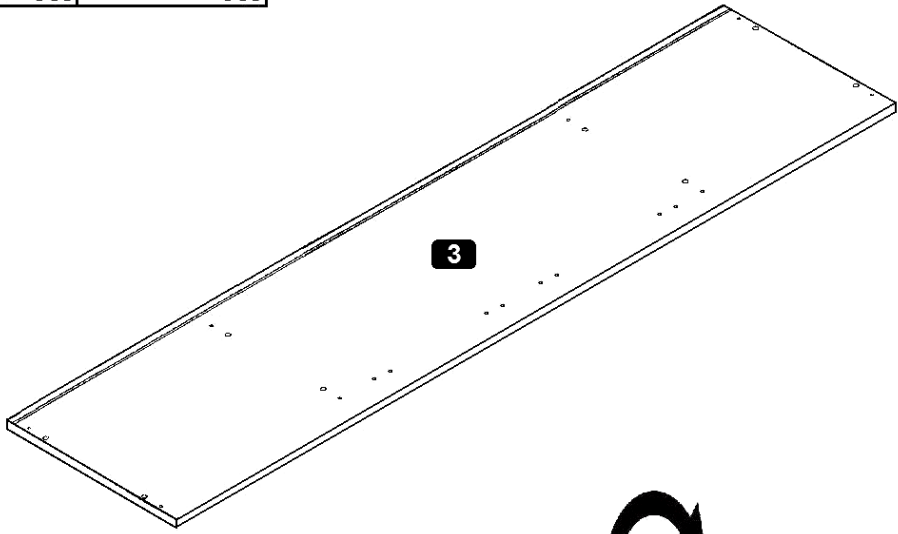
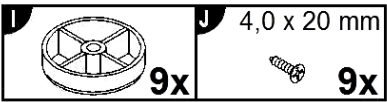

3



4

A	8,0 x 30 mm	B		C		G	h=2
	8x		22x		6x		4x

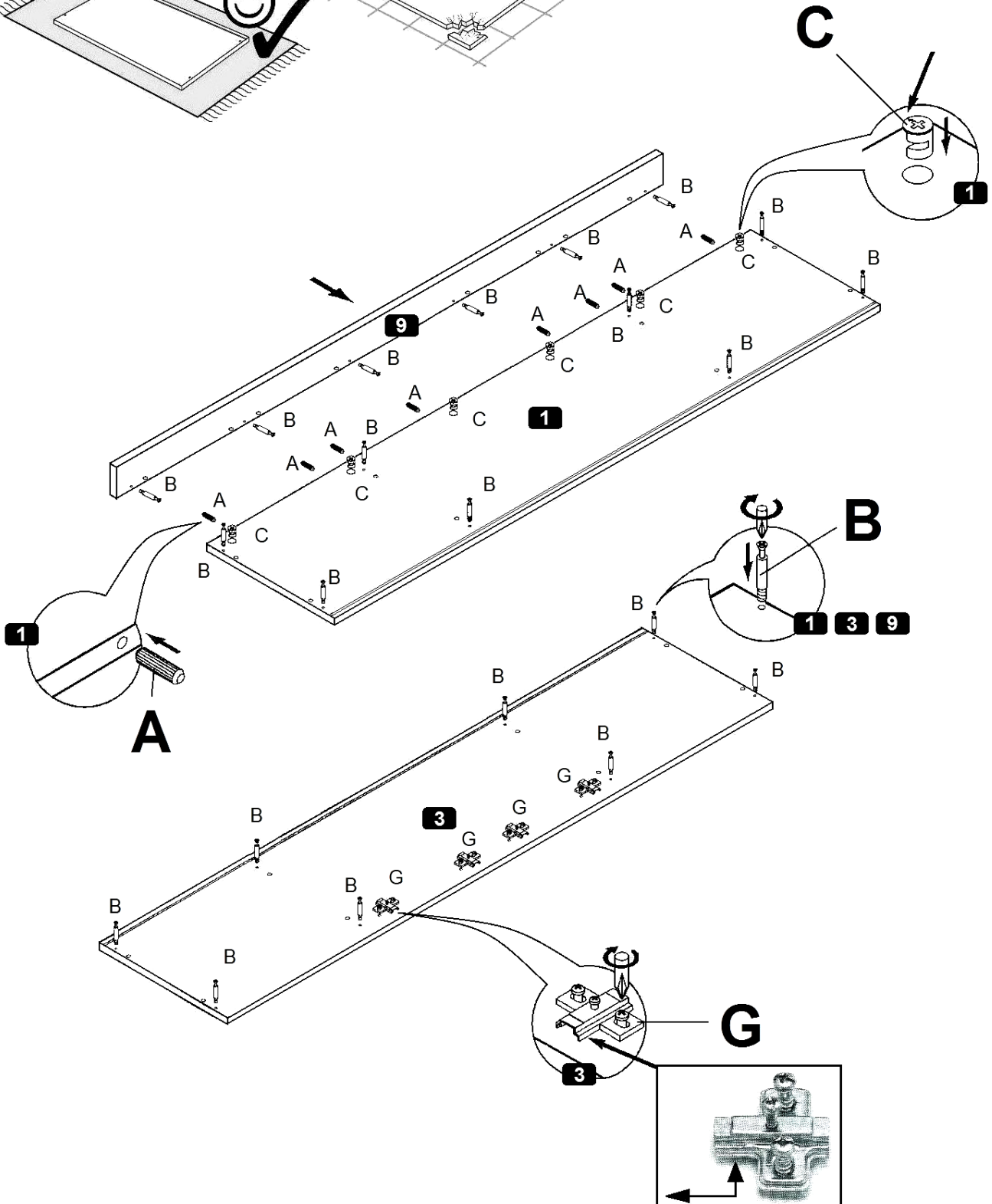
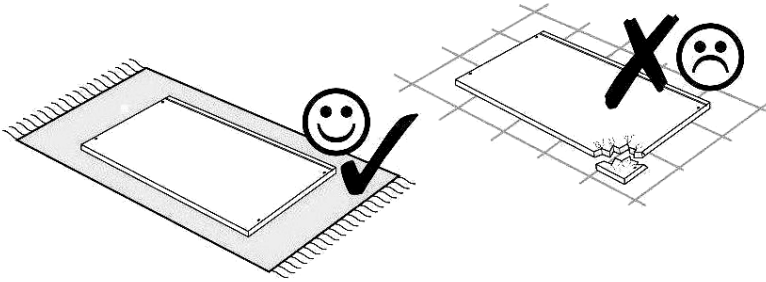
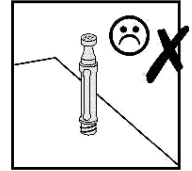
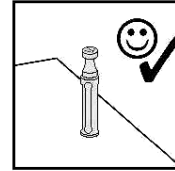

5

A 8,0 x 30 mm 24x	B 8x	C 24x	D 8x	E 3,0 x 12 mm 16x	27 x 310 mm 4x
M 6,3 x 13 mm 8x	R 250 mm 2x	S 3,5 x 13 mm 6x	Q Ø35 4x		

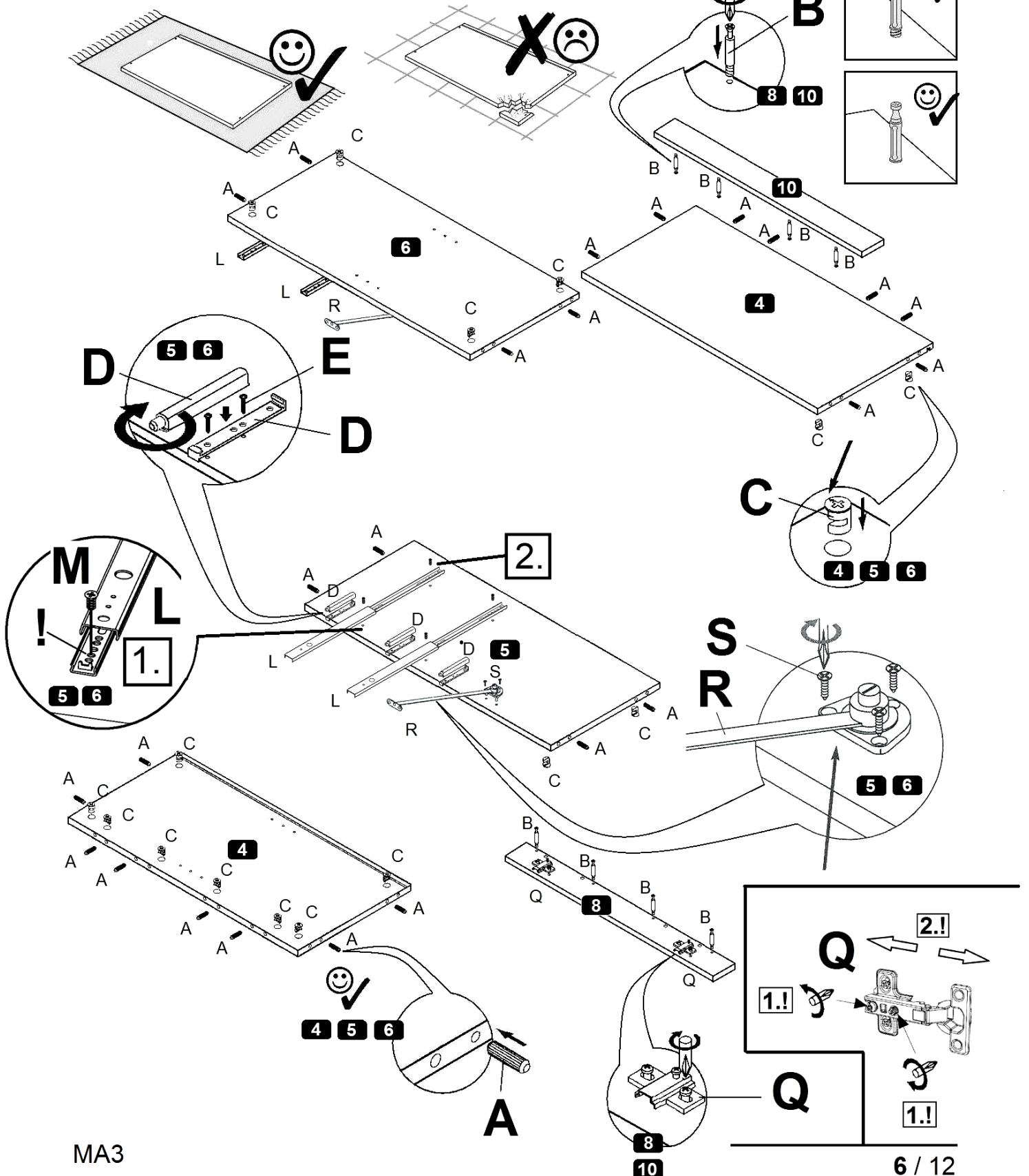

MA3

6

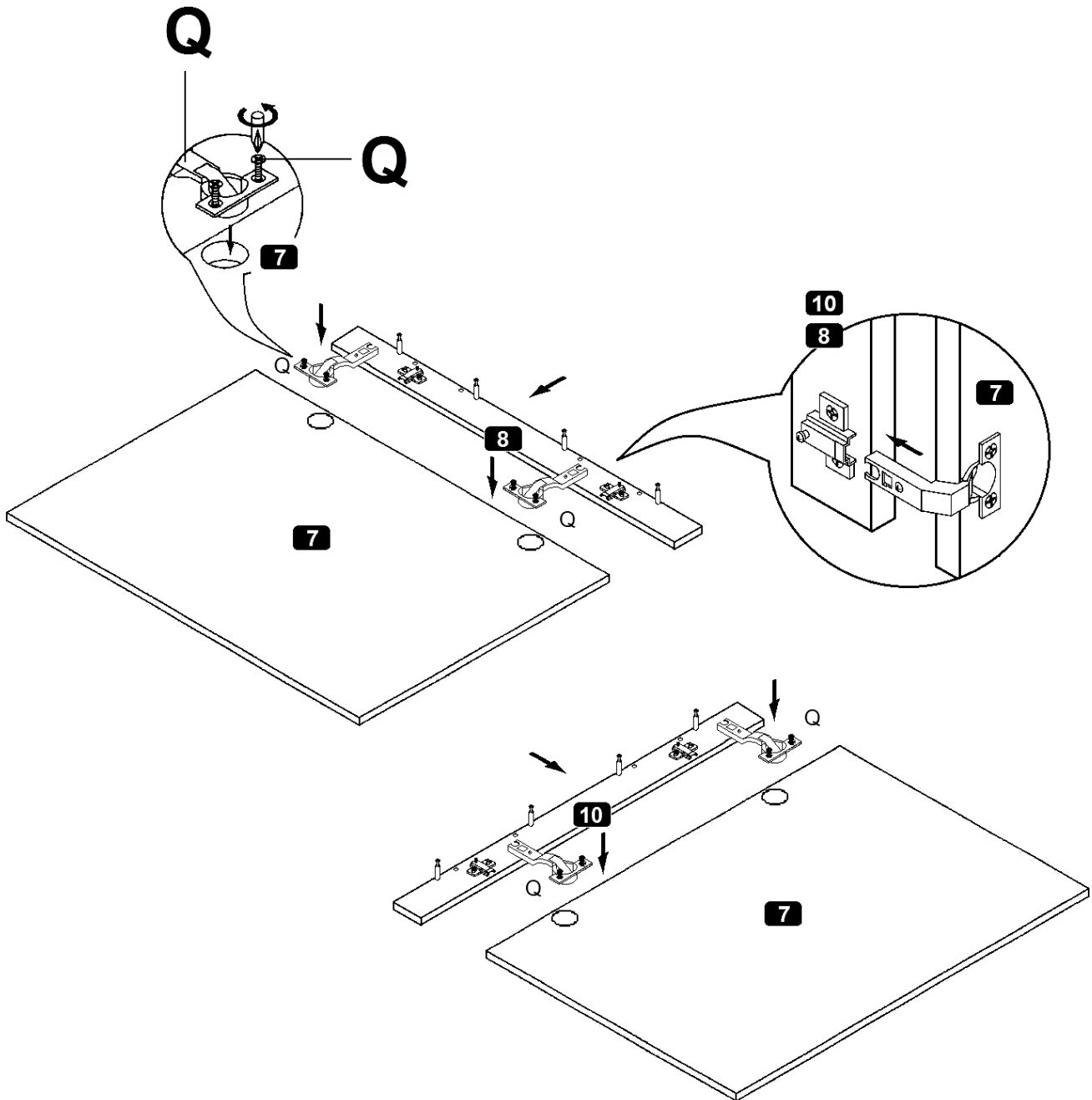
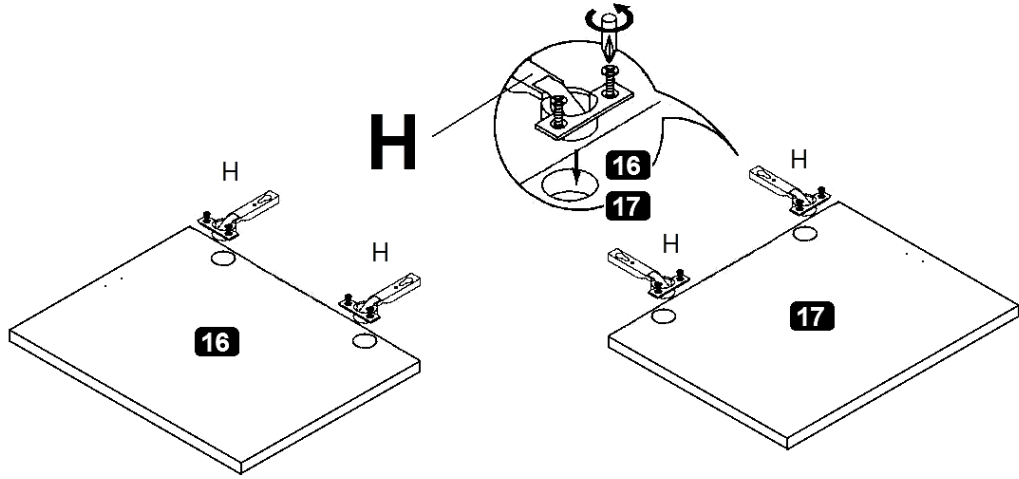
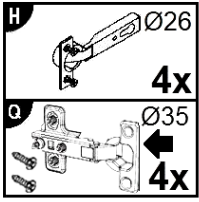

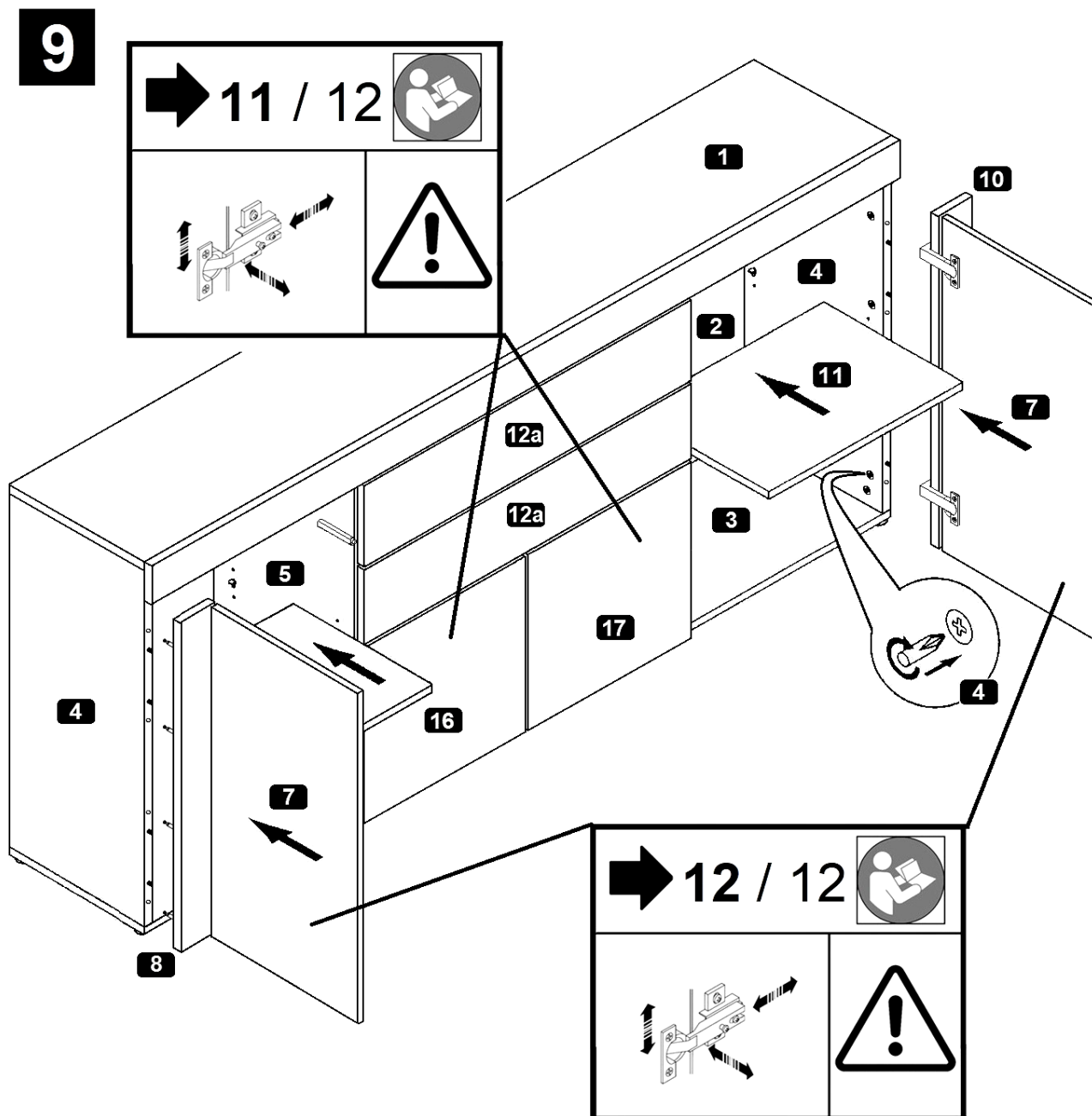

D Türen einstellen
(Scharniere justieren)

GB Adjusting the doors
(adjusting the hinges)

FR Régler les portes
(ajuster les charnières)

IT Sistemare le porte
(regolare le cerniere)

NL Deuren instellen
(scharnieren afstellen)

PL Nastawić drzwi
(wyregulować zawiasy)

CZ Vyrovnajte dvířka
(seřid'te závěsy)

RO Nastavenie dverí
(nastavenie závesov)

HU Állítsa be az ajtókat
(állítsa be a zsanérokat)

TR Reglare uşi
(ajustare balamale)

SK Kapílarín aýarlanması
(menteşelerin seviye ayarı)

RU Регулировка дверей
(регулировка шарнира)

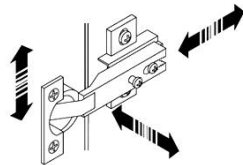

(D) Türen einstellen
(Scharniere justieren)

(GB) Adjusting the doors
(adjusting the hinges)

(FR) Régler les portes
(ajuster les charnières)

(IT) Sistemare le porte
(regolare le cerniere)

(NL) Deuren instellen
(scharnieren afstellen)

(PL) Nastawić drzwi
(wyregulować zawiasy)

(CZ) Vyrovnajte dvířka
(seřid'ťe závěsy)

(RO) Nastavenie dverí
(nastavenie závesov)

(HU) Állítsa be az ajtókat
(állítsa be a zsanérokat)

(SK) Reglare uši
(ajustare balamale)

(TR) Kapıların ayarlanması
(menteşelerin seviye ayarı)

(RU) Регулировка дверей
(регулировка шарнира)

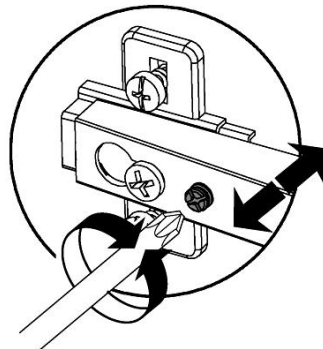
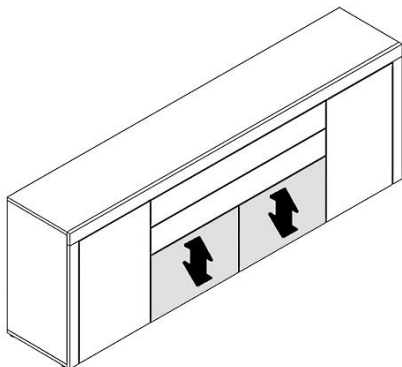
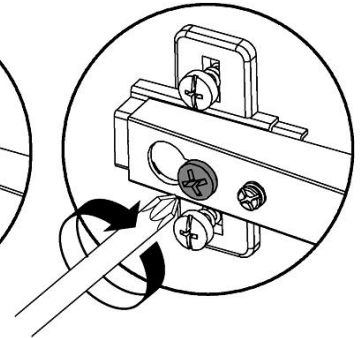
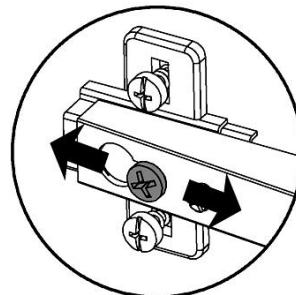
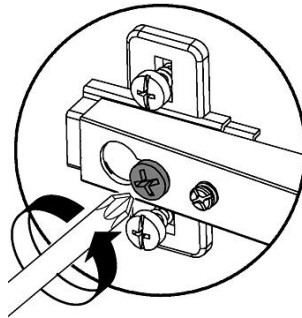
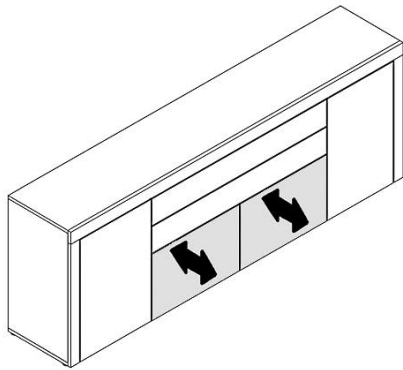
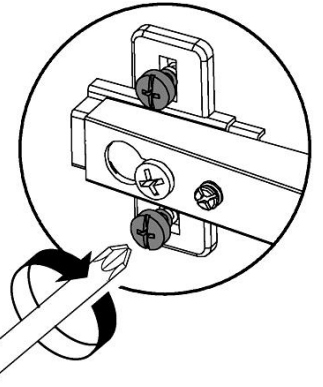
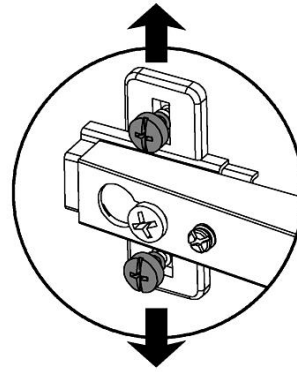
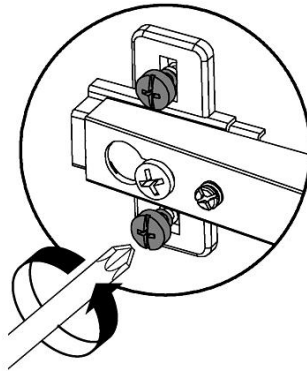
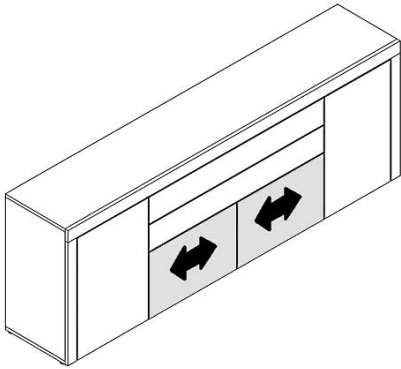

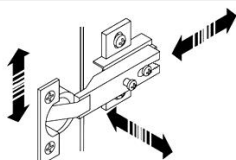
11

- (D) **Türen einstellen**
(Scharniere justieren)
- (GB) **Adjusting the doors**
(adjusting the hinges)
- (FR) **Régler les portes**
(ajuster les charnières)
- (IT) **Sistemare le porte**
(regolare le cerniere)
- (NL) **Deuren instellen**
(scharnieren afstellen)
- (PL) **Nastawić drzwi**
(wyregulować zawiasy)

- (CZ) **Vyrovnejte dvířka**
(seřid'te závěsy)
- (RO) **Nastavenie dverí**
(nastavenie závesov)
- (HU) **Állítsa be az ajtókat**
(állítsa be a zsanérokát)
- (SK) **Reglare uși**
(ajustare balamale)
- (TR) **Kapıların ayarlanması**
(mentşelerin seviye ayarı)
- (RU) **Регулировка дверей**
(регулировка шарнира)

