

Operating Instructions

Portable concrete mixer



content

Description	3
Specifications	4
Safety instructions	4
Unpacking	7
Assembly	7
Operation	11
Maintenance of equipment	12
The service life of	12
Warranty liability	12

⋮ |

Dear Customer!

The company expresses its deep gratitude for the purchase of cement mixers.

Attention! The Professional Series: Running time 42 hours per week.

Do not overload the mixer motor.

Read these instructions for use and maintenance. Keep it in a secure place.

Read these instructions for use and maintenance. Keep it in a secure place.

Description

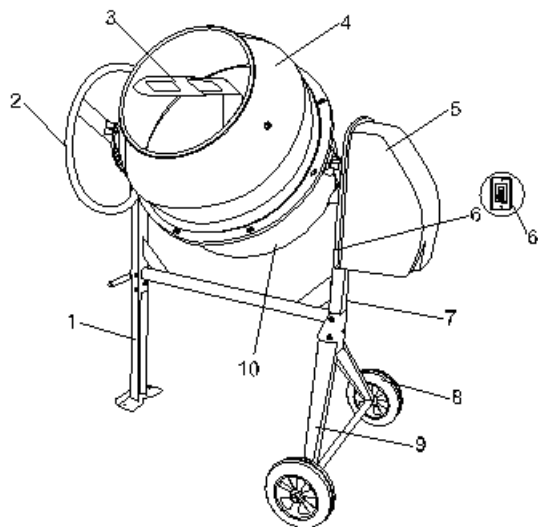

- | | |
|----------------------|------------------------|
| 1. front bracket | 6. switch |
| 2. rotary handle | 7. crossbeam |
| 3. blades for mixing | 8. wheel |
| 4. upper forecastle | 9. maintenance support |
| 5. engine block | 10. lower forecastle |

Safety notes

General safety rules with a concrete mixer

Attention! Concrete, is a product of high risk. By using a concrete mixer, not to be at risk of electrical shock, injury or fire, you should strictly follow the following basic safety rules. Read and remember these instructions before attempting any work on the concrete mixer. Keep safety instructions in a safe place.

Do not overload the mixer.

Do not use a mixer if the key does not work, "On / Off» («ON / OFF»). Concrete mixer in which faulty on / off button, posing an increased risk and should be repaired before use.

Disconnect the plug from the power source before making any adjustments, replacing accessories or supplies, or storing cement mixer. Such preventive safety measures reduce the risk of accidental activation of the mixer.

Keep out of reach of the mixer to outsiders who do not have skills to work with the concrete mixer. Concrete mixers are dangerous in the hands of people who do not have skills.

Spend the time necessary maintenance mixers. Duly served mixers allow a more easily and efficiently perform the work and improve safety. Any change or modification is prohibited because it may cause damage to the mixer and / or injury.

Regularly check the adjustment of the mixer, as well as the absence of deformations of the working parts, breakage of parts, and the condition of the concrete mixer, which can affect the malfunction. If there is any damage, and repair the mixer before starting work. Many accidents are caused by poorly maintained concrete mixers. Make a schedule of periodic servicing of your mixer.

Use only accessories recommended by the manufacturer for your model.

Workstation

The workplace should be clean and well lit.
Cluttered poorly lit workplaces cause injuries.



Do not use a mixer in hazardous environments such subject to: flammable liquids, gases or dust.



Keep bystanders a safe distance from the mixer running.

Do not be distracted - it can cause loss of control at work and cause injury.

Electrical

Before switching on, check that the voltage of your AC line mixers, check that all cables, plugs and sockets, in case of failure of these parts further use is prohibited.

Concrete mixers with double insulation does not require you to connect a plug with a third grounding wire. For the mixer without double-insulated connecting a plug to the grounded conductor necessarily

Avoid body contact with grounded surfaces such as pipes, radiators, stoves and refrigerators. Risk of electric shock increases dramatically if your body is in contact with a grounded object. If using a mixer in wet areas is unavoidable, the current to the mixer must be fed through a special device-breaker, disconnect the mixer leakage current. Rubber gloves and safety shoes electrician further increase your personal safety.

Do not expose the cement mixer to rain or wet conditions. Water trapped in the concrete mixer, significantly increases the risk of electric shock.

Handle with cord set. Never use the cord to pull the plug out of the socket. Keep the cord away from heat, oil liquids, sharp edges or moving parts. Replace damaged cords immediately. Damaged cords increase the risk of electric shock.

Under the action of the mixer outdoors, use Electroextension specifically designed for outdoor applications.

Personal security

Do not use a mixer while you are tired or under the influence of drugs or devices slow response, and alcohol or drugs. This can lead to serious injury. Wear appropriate clothing. Too loose clothing, jewelry or long flowing hair can be caught in moving parts working concrete mixer. Keep your hair, clothing,

and gloves away from moving parts. Hands should be dry, clean and free from traces of oily substances.

Avoid sudden turn. Make sure that the on / off switch is in the "OFF" («OFF») before turning on the mixer outlet.

Remove adjusting and / or installation keys before turning the mixer. Left key, hitting the moving parts of the mixer, can cause damage to the mixer or serious injury.

Use equipment that provides



your safety. Always wear safety glasses. Respirator, non-slip safety shoes, hard hat, or headphones must be used for appropriate conditions.

Note: The performance of this device may vary depending on local voltage supply line. The efficiency of the tool can also be used to influence an extension cord.

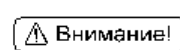

warnings, precautions and instructions in this manual do not apply to absolutely all situations that may arise. The operator should be aware that the practical control of the operation and compliance with all the precautions included in its immediate obligations.

Unpacking

Unpacking the product, make sure that all the parts in place. Refer to the figure on the back of the unit.

Assembly

Note: the numbers in the right corner of each figure correspond to the numbers on plastic bags with fasteners, appropriate for the assembly of the node.

Assembling the lower forecastle with reference arc.

Put on a flat and Spring washer on the bolt. Tighten the screw to secure the bottom M14X30 forecastle (10).

Note: the lower forecastle to be fixed before is removed from the carton.

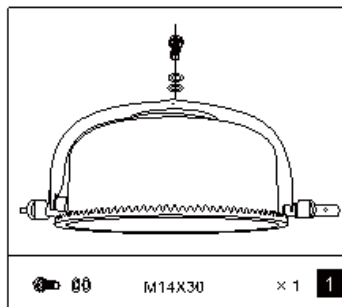

The assembly supported by the support.

Install the stand vertically as shown in the figure.

Place the flat washer to maintenance support (9), then slide the wheel (8) and another flat washer.

Insert the pin into the holes of the supporting feet (9).

Fold each on both sides, the pins from falling out the holes.

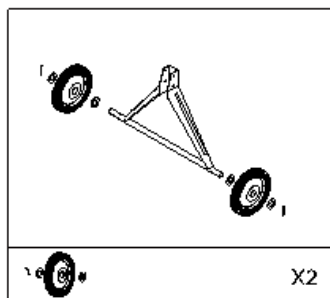

Assembling the frame.

Connect to the cross beam (7) front bracket (1) as shown in the figure. Plug the holes in the two M8x65 bolts with washers and screw the nut on the other side. Also tighten the bolt M8x55 with washer into the nut in the frame. Tighten firmly with a wrench.

Turn the frame and attach the support to the wheels (9) as shown in the figure. Insert and tighten the screws.

Make sure all nuts and bolts are tight.

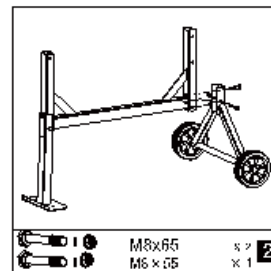
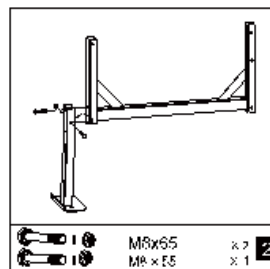

Assembling the lower forecastle.

Be careful with the help of two people set the lower forecastle (10) with reference to the arc frame as shown in the figure.

On each side of the holes align with bearing and insert the bolts, nuts and washers. Tighten the bolts with a wrench.

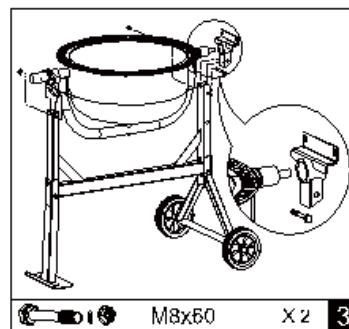

Rotary handle

1. Gently slide the lock plate on the axis of a large diameter as shown in the figure. Secure with two screws M8x25 and washers.

2. Screw the bolt into the pipe M8H50 rotary handle. Insert the spring washer and then the tube. Hold the spring finger, put the handle on the shaft. Press the

handle down until the holes in the shaft and tube rotary handle not match. Insert the bolt M10x70, washers and lock the two nuts. The spring rate adjustable bolt M8x 50.

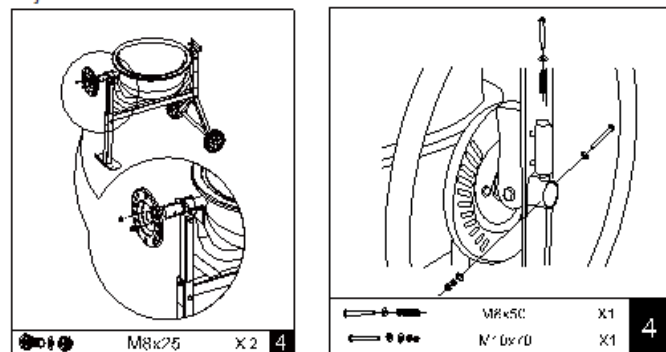

The blades for mixing

1. Set the mixer blades inside the lower forecastle, as shown in the figure.
2. At the bottom of the forecastle has two openings. Use the mounting screws M8x16 and bolts M8x20, which are inserted from the outside of the forecastle. Nuts and washers are installed from the inside.

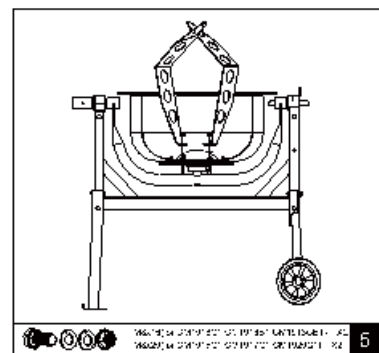

Note: Soft aluminum washers must be installed between the blades and the tank for leaks.

Upper forecastle

1. Place the rubber gasket in the groove of the lower forecastle. The holes in the gasket fit holes for bolts.

2. Install the upper rim of the lower forecastle on the forecastle, make sure that the holes are aligned and arrows came together.



3. Insert the six screws with a Phillips-head screws M6x16 (for SM1913V1) together with washers and eight screws and washers (for all others) into the holes on the crown. Put on each screw from the bottom washer, nut and tighten.
4. Attach the blade to the upper forecastle M8x16 screws through the holes on the outside.
5. Leather washers are installed in between the blades and the upper forecastle. Tighten the blade from the inside, using a nut.
6. Make sure that all the blades are securely fastened.

The engine block

Align the keyhole slots, shifting the engine block on the pinion shaft. Secure the unit to the frame with two bolts M8x25 and one M8H50 and washers.

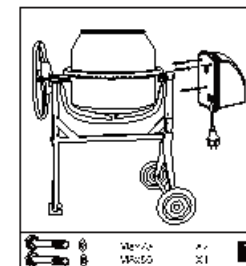

Operation

Turn on / off the mixer.

Press the green button switch (6) to turn the mixer. To turn off - press the red

button switch (6).

The slope of the tank

Spring actuated rotary handle provides a secure hold positions in the drum storage and unloading work.

Tank fixed in these positions by means of teeth on the rotary handle, which engage with the grooves on the locking disk. To tilt the tank should pull on a rotation handle to disengage the engagement. This allows you to turn the handle and the tank in one direction.

The provisions of the mixer tank during loading and mixing of materials.

Lime solution Unloading Concrete Storage

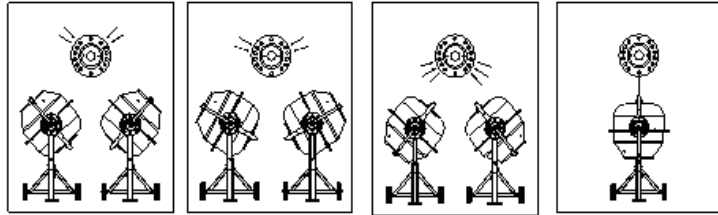

Download

Connect the cable to the mixer. Then connect the mixer to the network. Start the mixer before loading. Always load only the rotating drum. Do not throw stuff in a concrete mixer to avoid bounce back from the drum. Ship over the edge.

Note: The engine is equipped with a mixer thermal protection to prevent overheating. Thermal protection is automatically activated when overheated and shut off automatically when the engine cooling.

To get the best results when working:

1. Add the required amount of gravel in the drum.
2. Add the cement.
3. Add the required amount of sand.
4. Pour the water into the drum.

Unloading

Do not turn off the mixer when it is complete. Unloading should be done only when the rotating drum.

Maintenance of equipment

Thoroughly clean the mixer at the end of the working day. Keep it clean. Once cured, the cement must be removed from the drum. Do not attempt to clean the accumulated stale concrete trowel, hammer and other tools, as this may cause damage to the concrete mixer. The drum is cleaned for approximately 2 minutes using a mixture of water and gravel size of about 25 mm. After cleaning unload a mixture of water and gravel and wash drum spray water inside and outside.

Do not pour water on the motor housing and especially the vents. Remove any foreign matter from the engine casing. Do not use harsh chemicals and liquids to clean the body parts

Life

The service life of products is 1 years.

The warranty period in accordance with warranty card