

NOTE:

This brochure contains IMPORTANT safety info. Please read and keep for future reference.

MAINTAINANCE AND WARNING



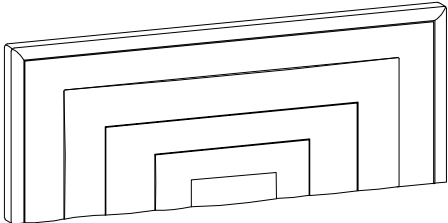
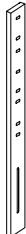

- 1.Keep furniture away from heat sources.
- 2.Do not clean furniture with harsh cleaner or polishes.Do not use detergents,solvents,abrasives,spray packs or leather cleaner. Use non-color mild soa with warm water to clean spills(Mix 1:10 soap to water).
- 3.Do not place furniture under direct sunlight,material will possibly fade over time.
- 4.Do not use on site dry cleaning machine.Children should not climb or jump on the furniture.
- 5.Do not write on furniture that is not protectedby a padded barrier.
- 6.Not for commercial use,only for residential use.

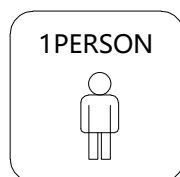

PARTS LIST

A		x1	B	x2
				



HARDWARE LIST





①	x6	②	x6	③	x6	④	x2	⑤	x2
									
Bolt		Flat washer		Spring washer		Nut		Adjust leg	
M8*55mm									

⑥	x4	⑦	x2
			
Square felt mat		Round felt mat	

TOOL LIST

⑧	x1
	
Allen key	
M8	

HARDWARE SPARE LIST

①	x1	②	x1	③	x1	⑥	x1	⑦	x1
									
Bolt		Flat washer		Spring washer		Square felt mat		Round felt mat	
M8*55mm									

ASSEMBLY INSTRUCTIONS

STEP-1

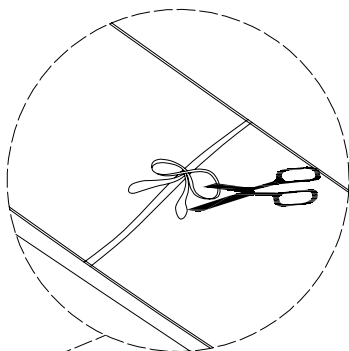

Use scissor to cut off the belt, and then take out the packing of legs.

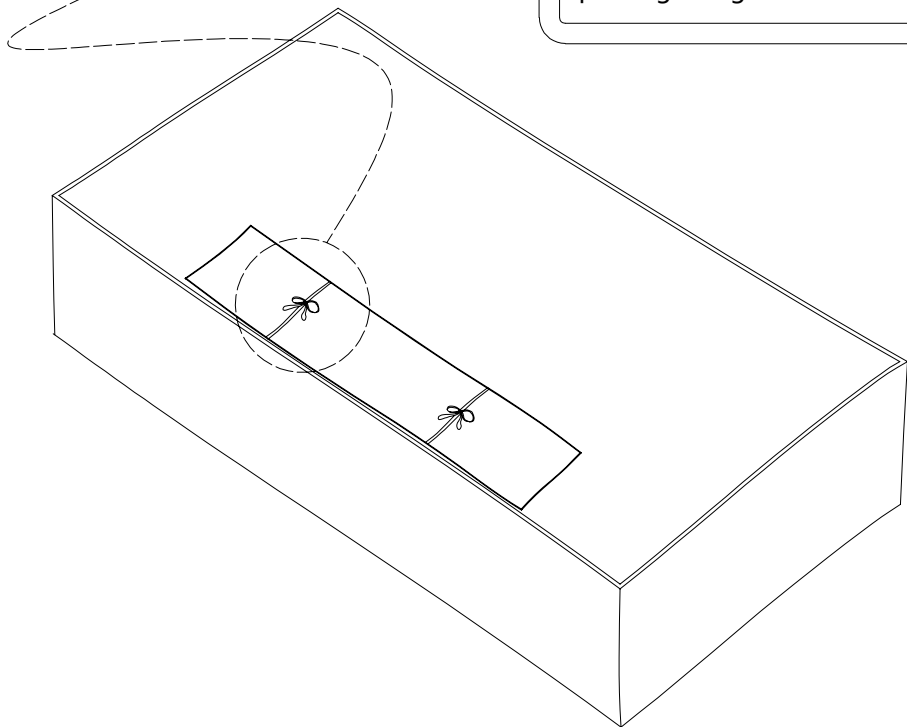





ASSEMBLY INSTRUCTIONS

STEP-2

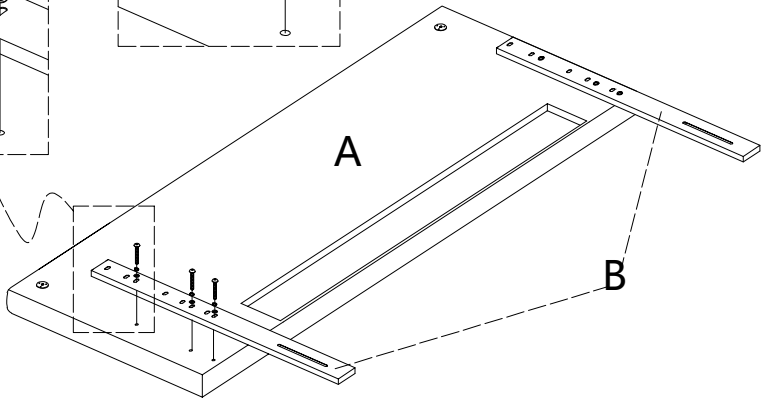
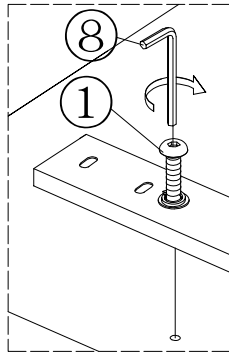
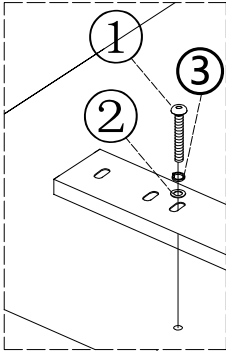
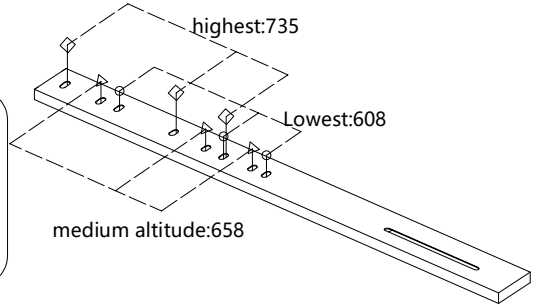

Install according to the screw hole position, the headboard height from the ground can be divided into three gears, as shown in the figure:



①	x6	②	x6	③	x6	⑧	x1
							
Bolt		Flat washer		Spring washer		Allen key	
M8*55mm						M8	

ASSEMBLY INSTRUCTIONS

STEP-3



Attention:
After installation, Adjust the headboard
distance from the wall with adjustable feet

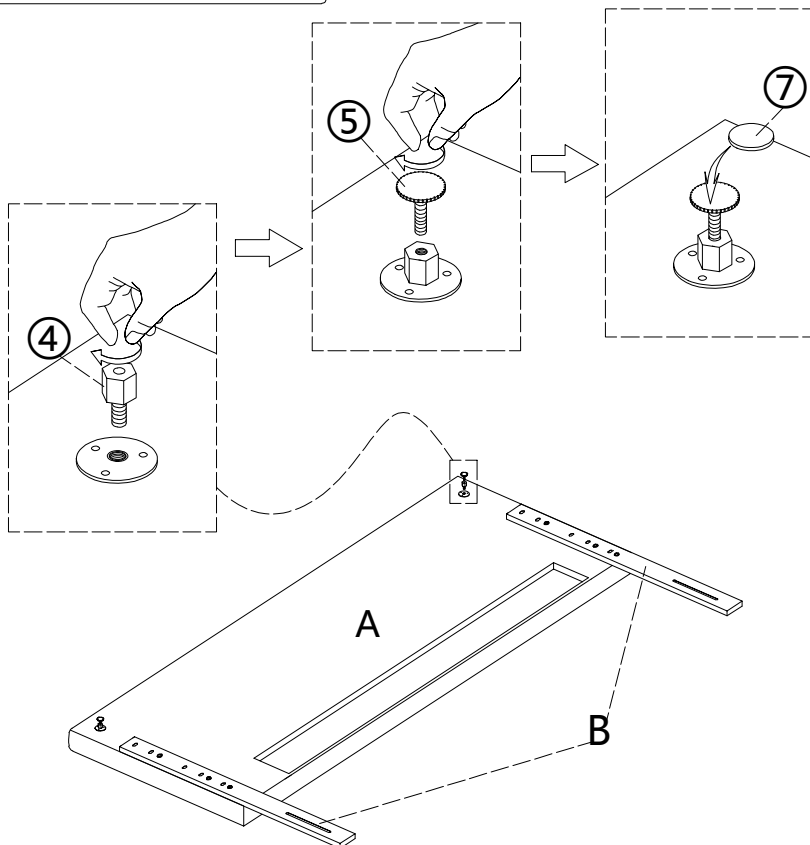

④	x2
	
Nut	

⑤	x2
	
Adjust leg	

⑦	x2
	
Round felt mat	

ASSEMBLY INSTRUCTIONS

STEP-4

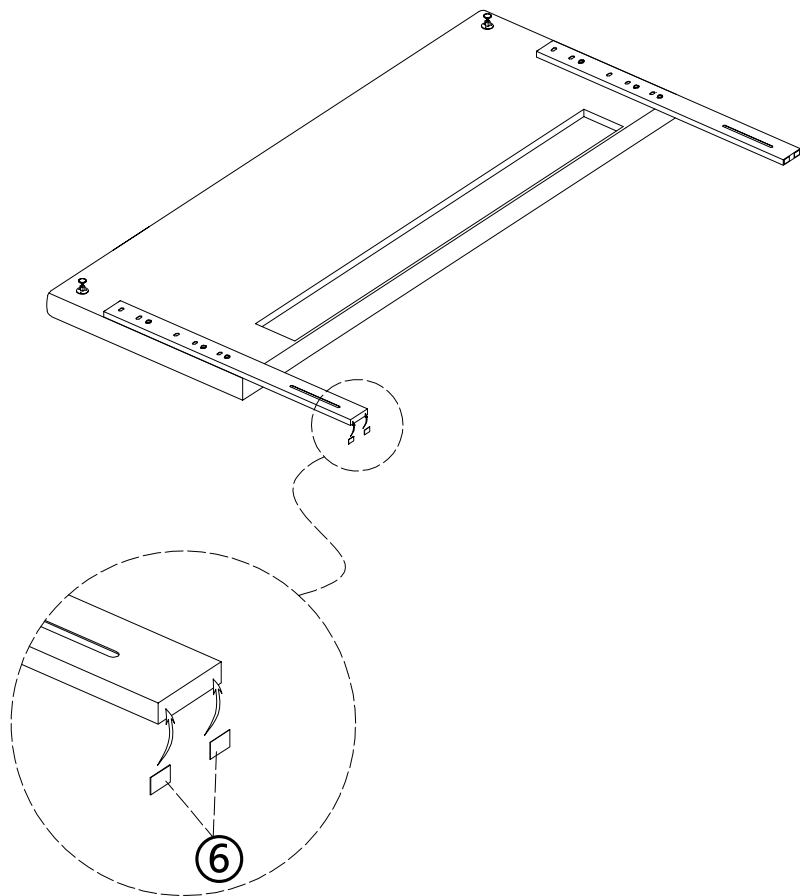

⑥	x4
Square felt mat	

WARRANTY

1. We strive to offer high-quality products, and we also try our best to satisfy each and every customer that orders from us with product or service as needed.
2. We provide 30 days warranty starting from the time you receive the item. Each customer must provide a record of their order such as the order number, or item receipt for any items that are out of the warranty period you may also still receive.
3. Replacement parts by purchasing them with our company if they are available.