

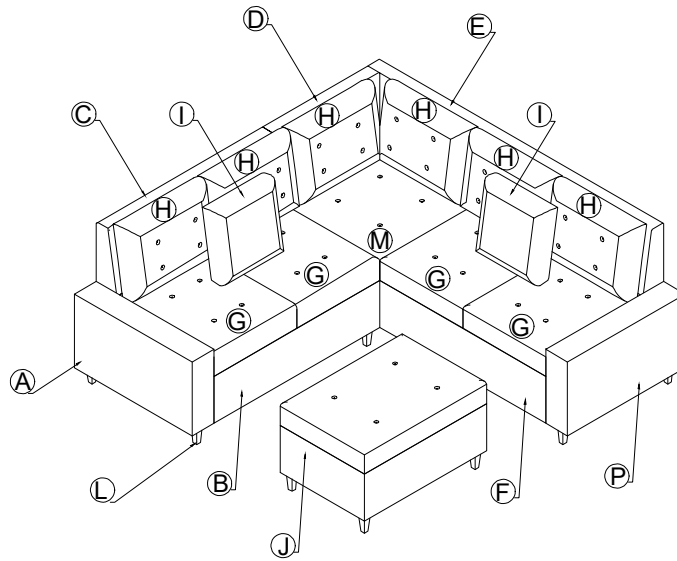

ASSEMBLY INSTRUCTION

U385/U386



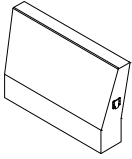
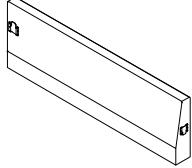
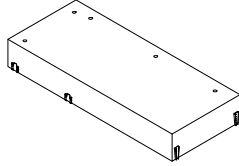
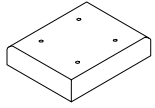
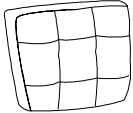
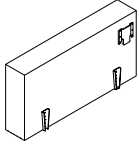
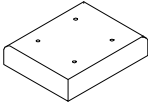
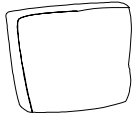

PARTS LIST

BOX 1:

			
(D): 1 PC	(E): 1 PC	(F): 1 PC	(M): 1 PC
			
(H): 4 PCS	(P): 1 PC	(G): 2 PCS	(I): 1 PC
			
(L): 4 PCS			

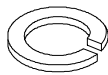
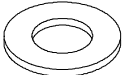
HARDWARE

				
5/16"*80mm (1): 5 PCS	Ø5/16"*12mm (2): 5 PCS	Ø5/16"*19mm (3): 5 PCS	5/16" (4): 5 PCS	(5): 1 PC

*Carefully unpack parts/hardware from the box and storage of seat body, place on a clean flat surface.
 *Attention: After remove the pillow from the boxes, please pat on the pillow, swipe gently on the fabric by using hand to reduce the wrinkle.

BOX 2:

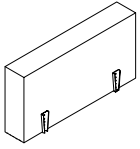

(A): 1 PC

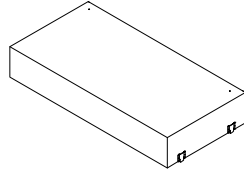

(B): 1 PC

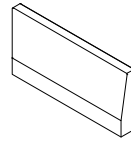

(C): 1 PC

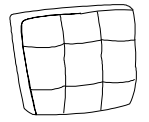

(H): 2 PCS

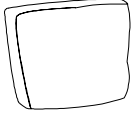

(I): 1 PC

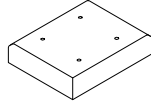

(G): 2 PCS



(L): 4 PCS

HARDWARE



5/16"*80mm

(1): 2 PCS

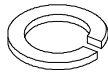

Ø5/16"*12mm

(2): 2 PCS

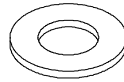

Ø5/16"*19mm

(3): 2 PCS

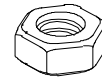

5/16"

(4): 2 PCS



(5): 1 PC

BOX 3:

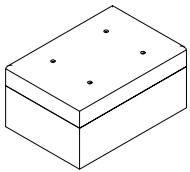



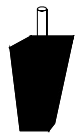

(J): 1 PC



(L): 4 PCS

**Carefully unpack parts/hardware from the box and storage of seat body, place on a clean flat surface.
Attention: After remove the pillow from the boxes, please pat on the pillow, swipe gently on the fabric by using hand to reduce the wrinkle.



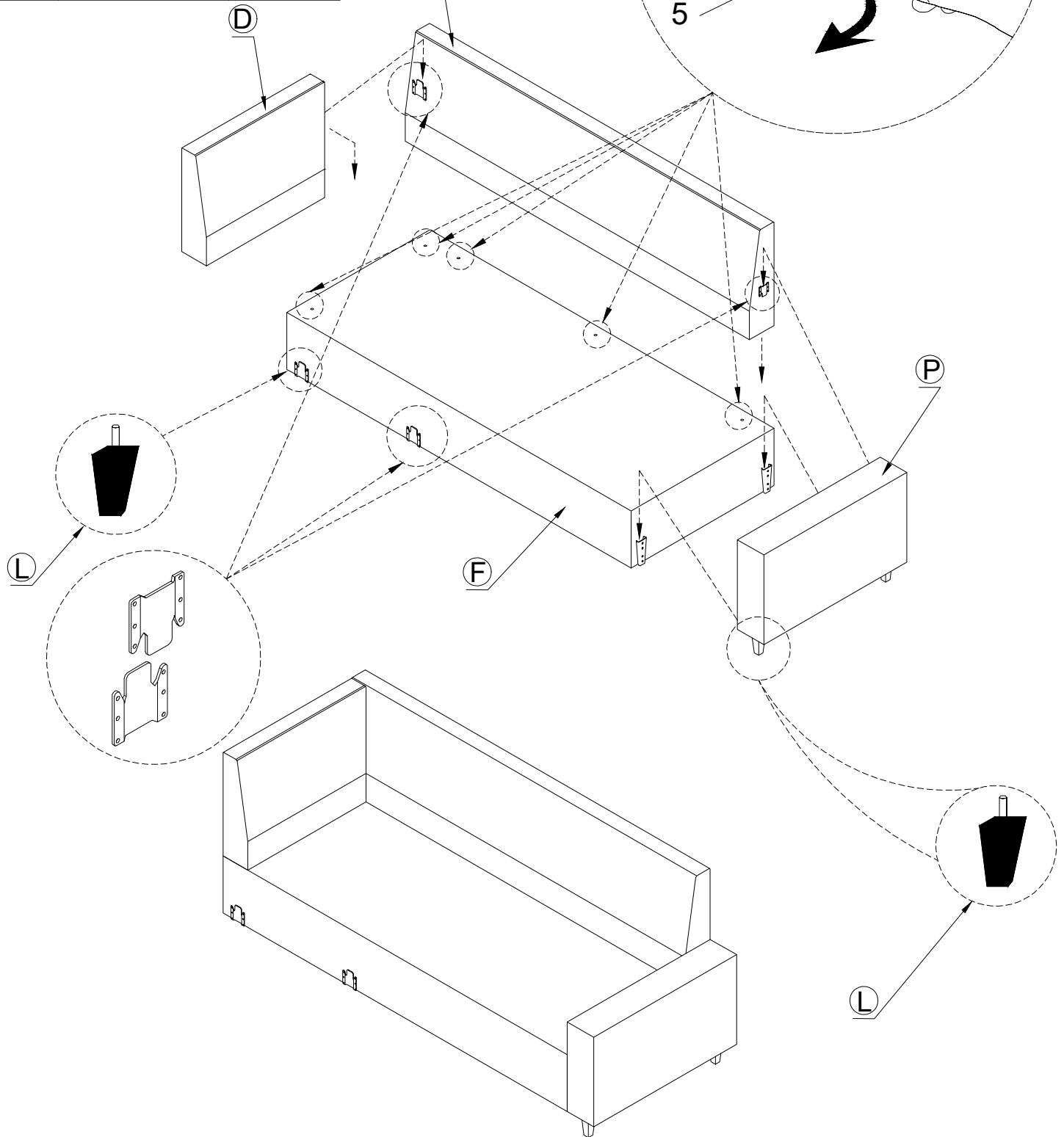
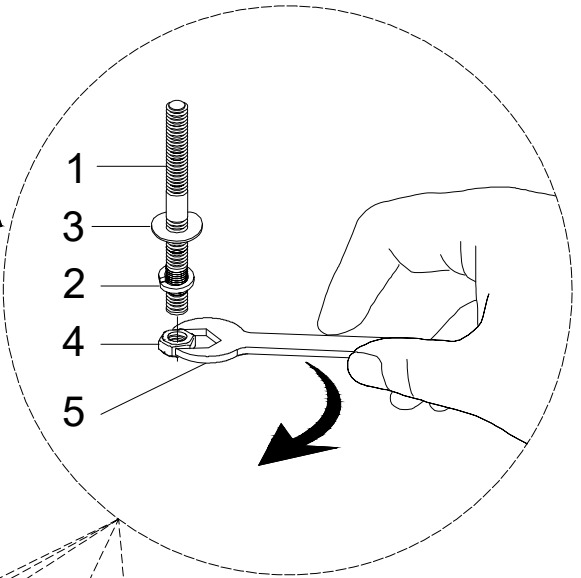
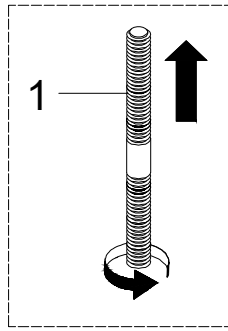

STEP 1

1		5 PCS
2		5 PCS
3		5 PCS
4		5 PCS
5		1 PC



*Carefully unpack parts/hardware from the box and storage of seat body, place on a clean flat surface.
 *Attention: After remove the pillow from the boxes, please pat on the pillow, swipe gently on the fabric by using hand to reduce the wrinkle.

STEP 2

1		2 PCS
2		2 PCS
3		2 PCS
4		2 PCS
5		1 PC

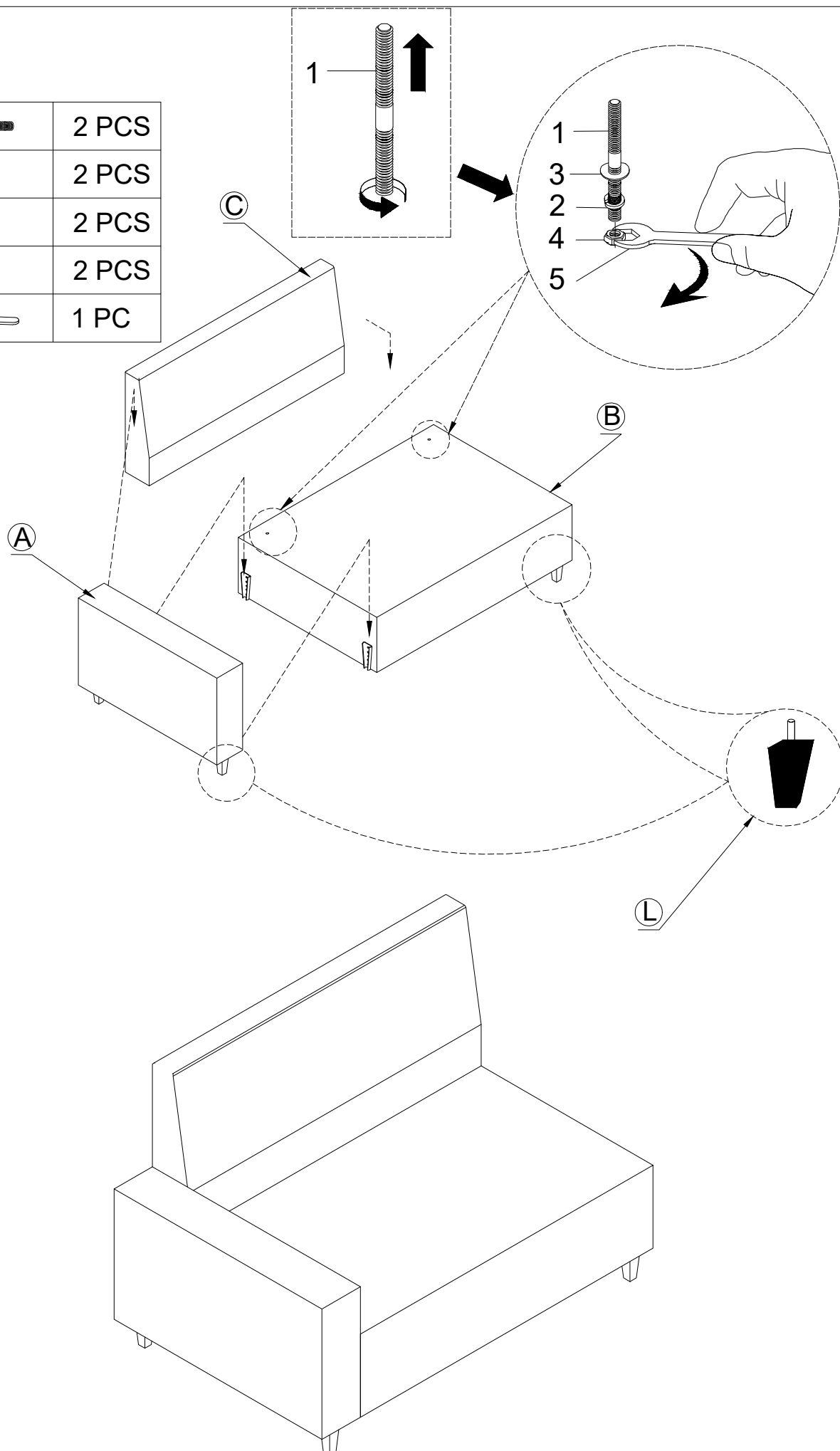

*Carefully unpack parts/hardware from the box and storage of seat body, place on a clean flat surface.
 *Attention: After remove the pillow from the boxes, please pat on the pillow, swipe gently on the fabric by using hand to reduce the wrinkle.

STEP 3

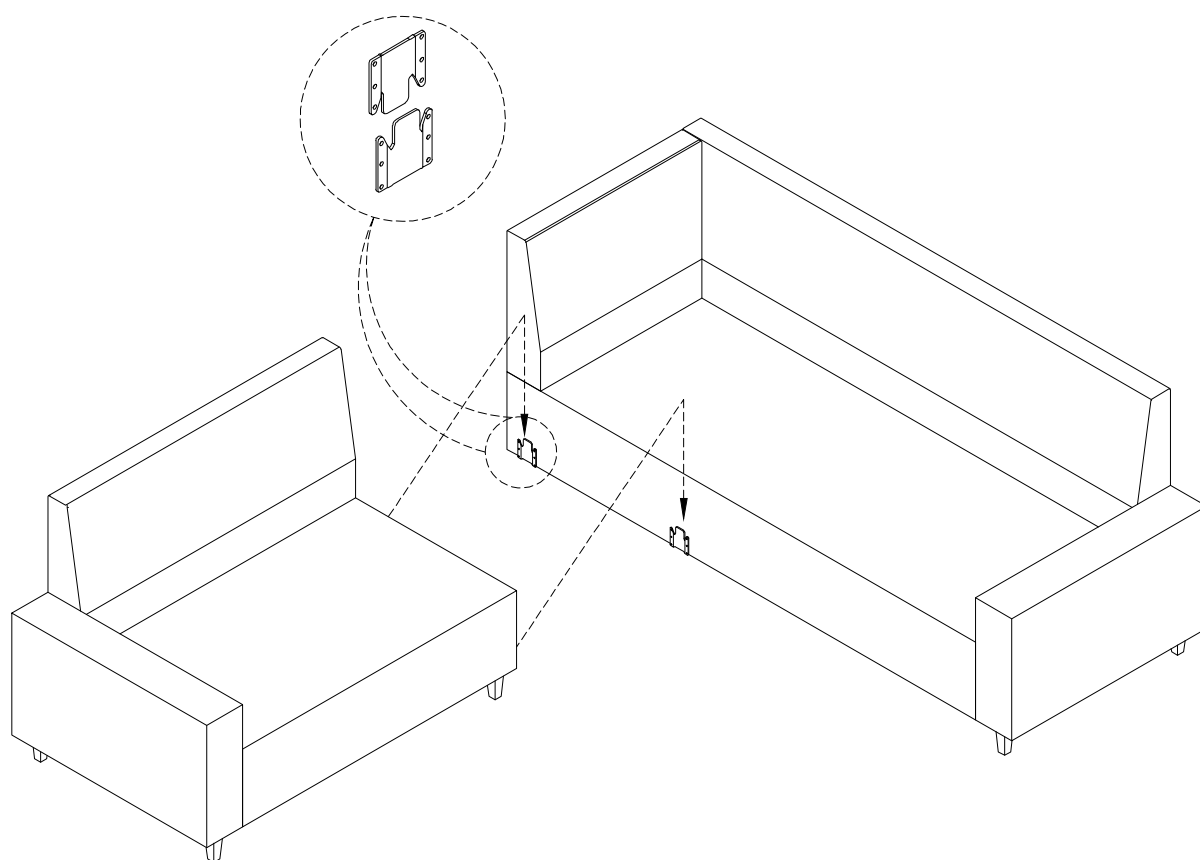

**Carefully unpack parts/hardware from the box and storage of seat body, place on a clean flat surface.
Attention: After remove the pillow from the boxes, please pat on the pillow, swipe gently on the fabric by using hand to reduce the wrinkle.

STEP 4

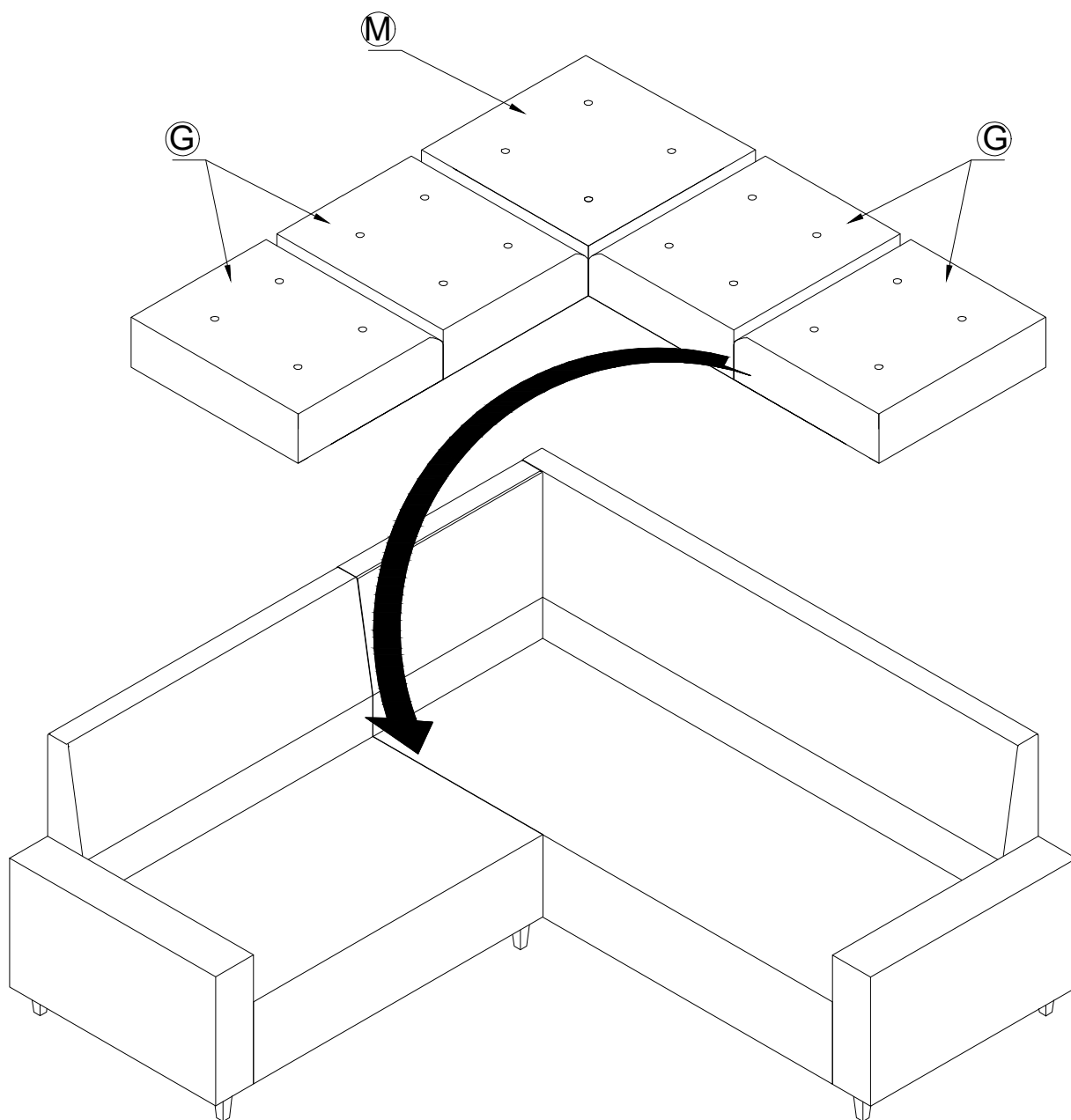

**Carefully unpack parts/hardware from the box and storage of seat body, place on a clean flat surface.
Attention: After remove the pillow from the boxes, please pat on the pillow, swipe gently on the fabric by using hand to reduce the wrinkle.

STEP 5

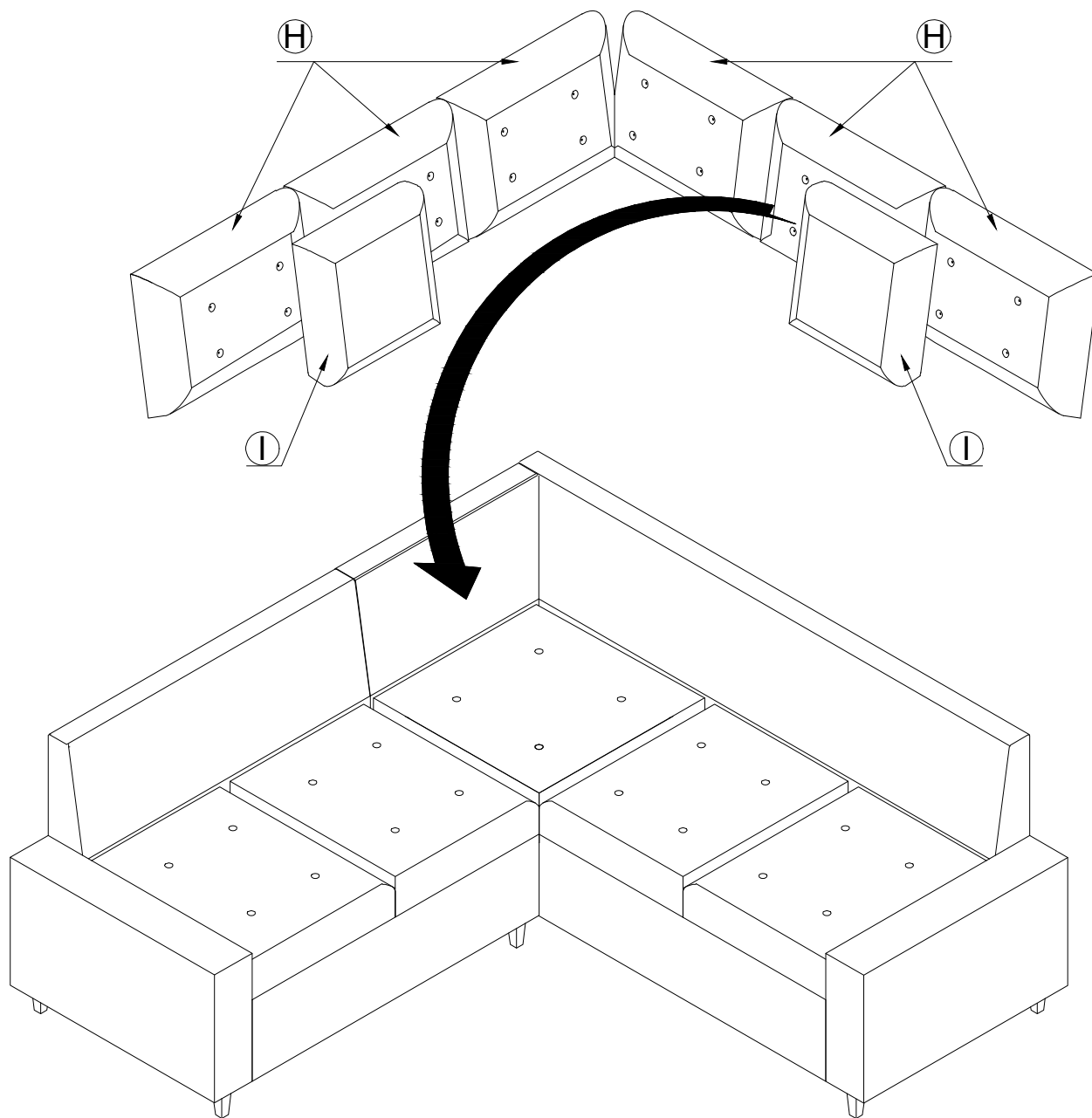

**Carefully unpack parts/hardware from the box and storage of seat body, place on a clean flat surface.
Attention: After remove the pillow from the boxes, please pat on the pillow, swipe gently on the fabric by using hand to reduce the wrinkle.

STEP 6

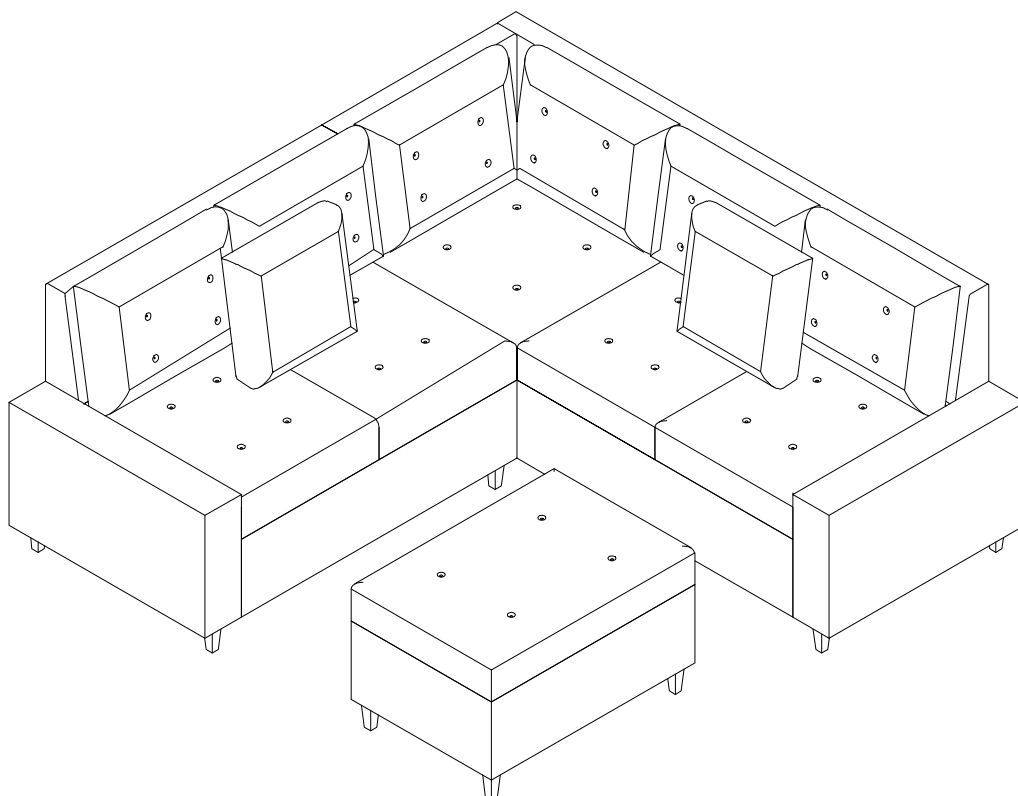
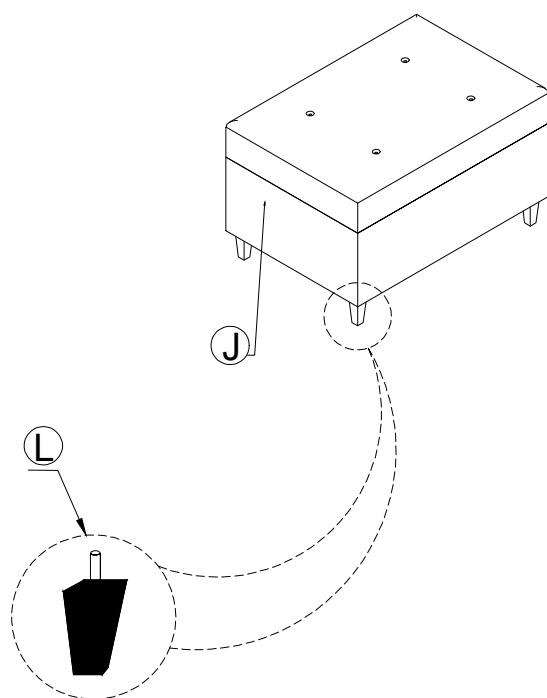

**Carefully unpack parts/hardware from the box and storage of seat body, place on a clean flat surface.
Attention: After remove the pillow from the boxes, please pat on the pillow, swipe gently on the fabric by using hand to reduce the wrinkle.