

W L Desk

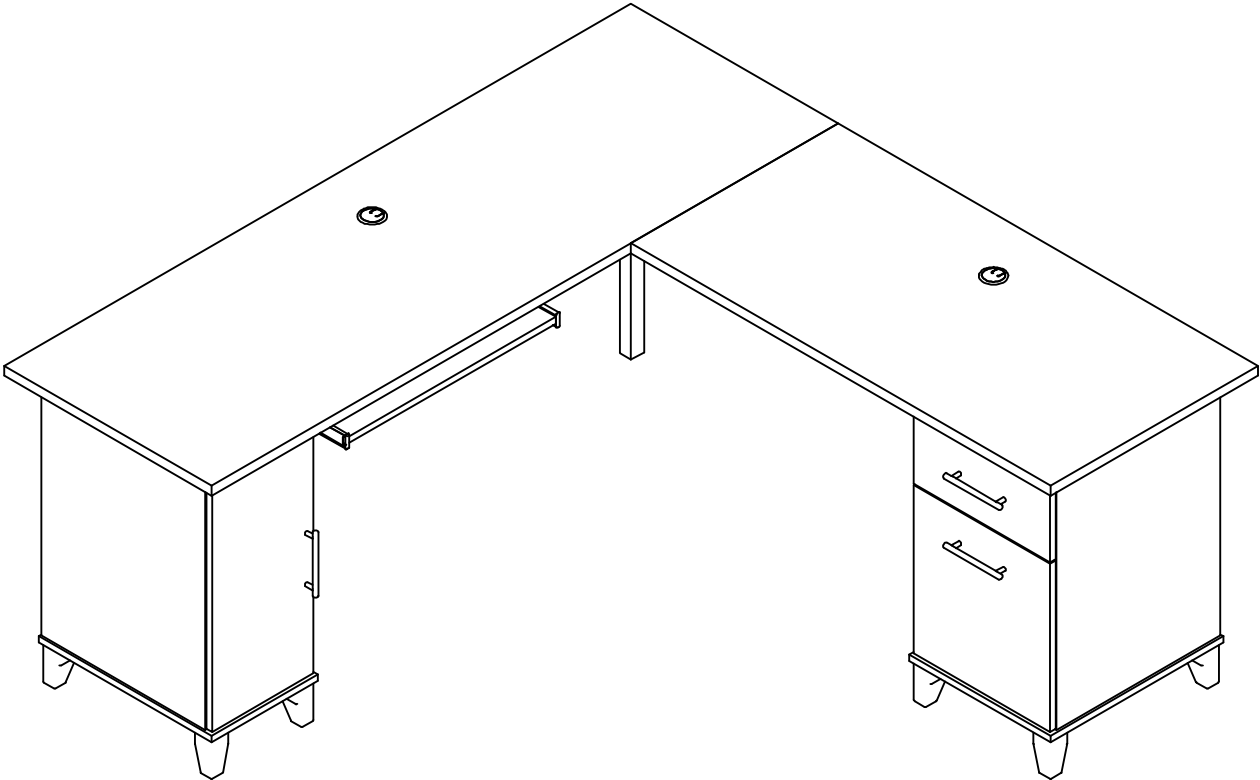

Get Ready to Assemble

For best results, keep these tips in mind:

- ① We know you want to finish this assembly as quickly as possible, but trust us: you'll have a better experience if you take it one step at a time.
- ② Give yourself some room to work near where you want the fully assembled product.
- ③ If your floor isn't carpeted, assemble this product on the empty carton to avoid scratching.
- ④ Do you have a friend who owes you a favor? Some steps may go a little easier with a second set of hands.

DOs

- ✔ Use a #2 Phillips head screwdriver (or other handheld tools as indicated)
- ✔ Wear safety glasses at all times during assembly
- ✔ Carefully follow the instructions in this guide and complete all steps in order
- ✔ Give us a call if you're having trouble with a particularly tricky step

DON'Ts

- ✘ We know power tools are quick and easy, but you shouldn't use them when assembling this product (unless otherwise specified)
- ✘ Never move your furniture with items inside or resting on the surface
- ✘ Do not attempt to use this product before all steps have been completed

Assembly Option 1

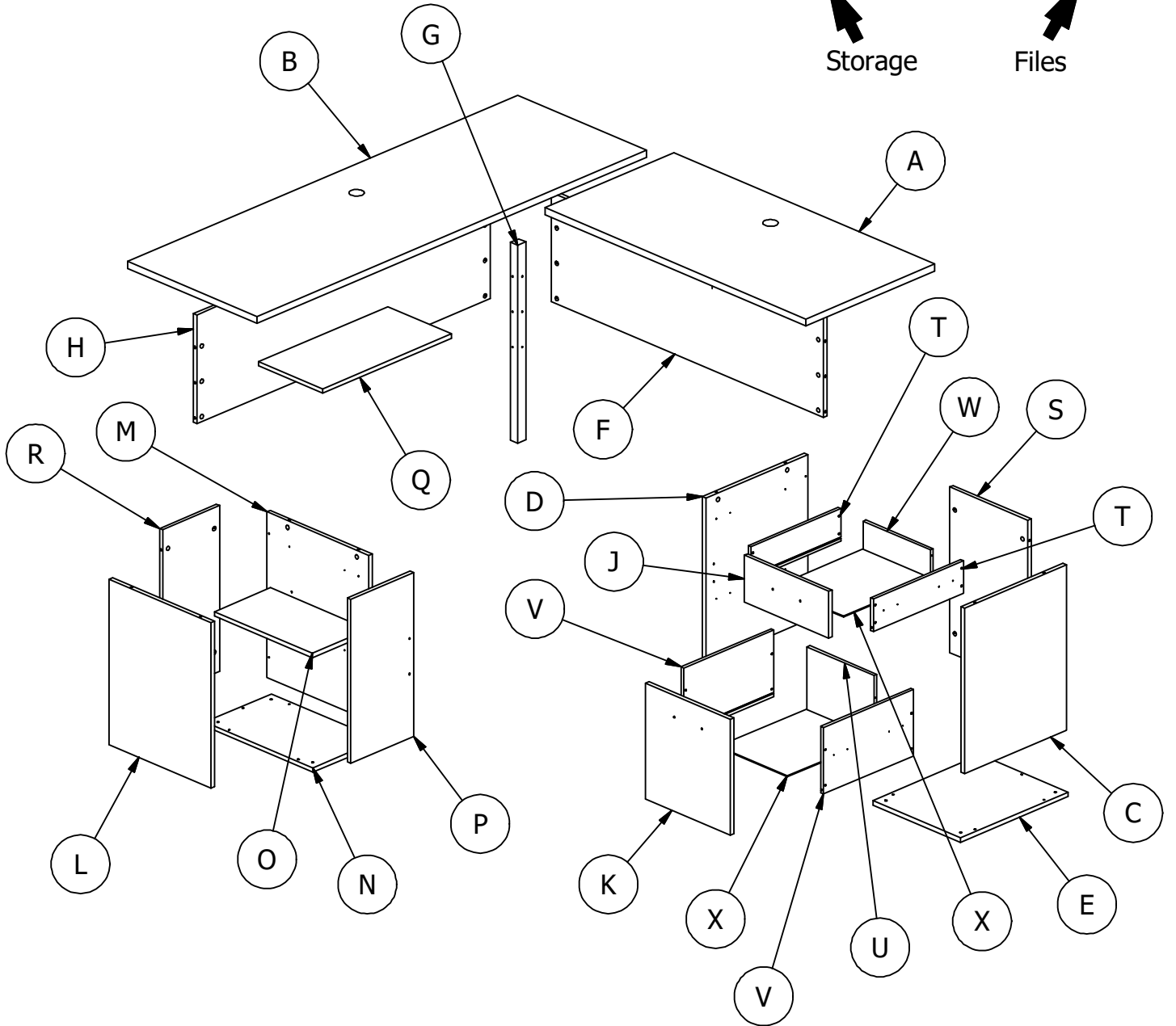
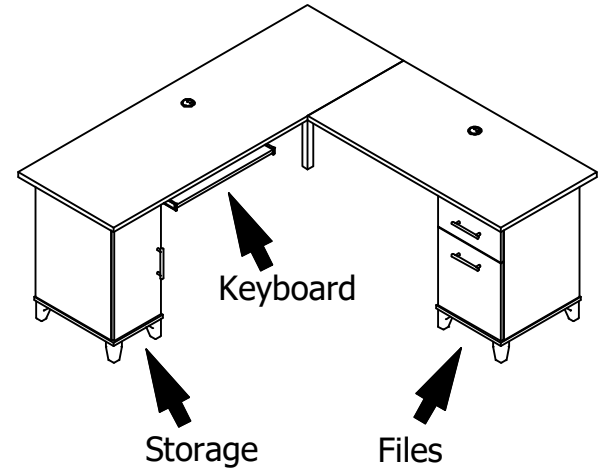

Assembly Option 2

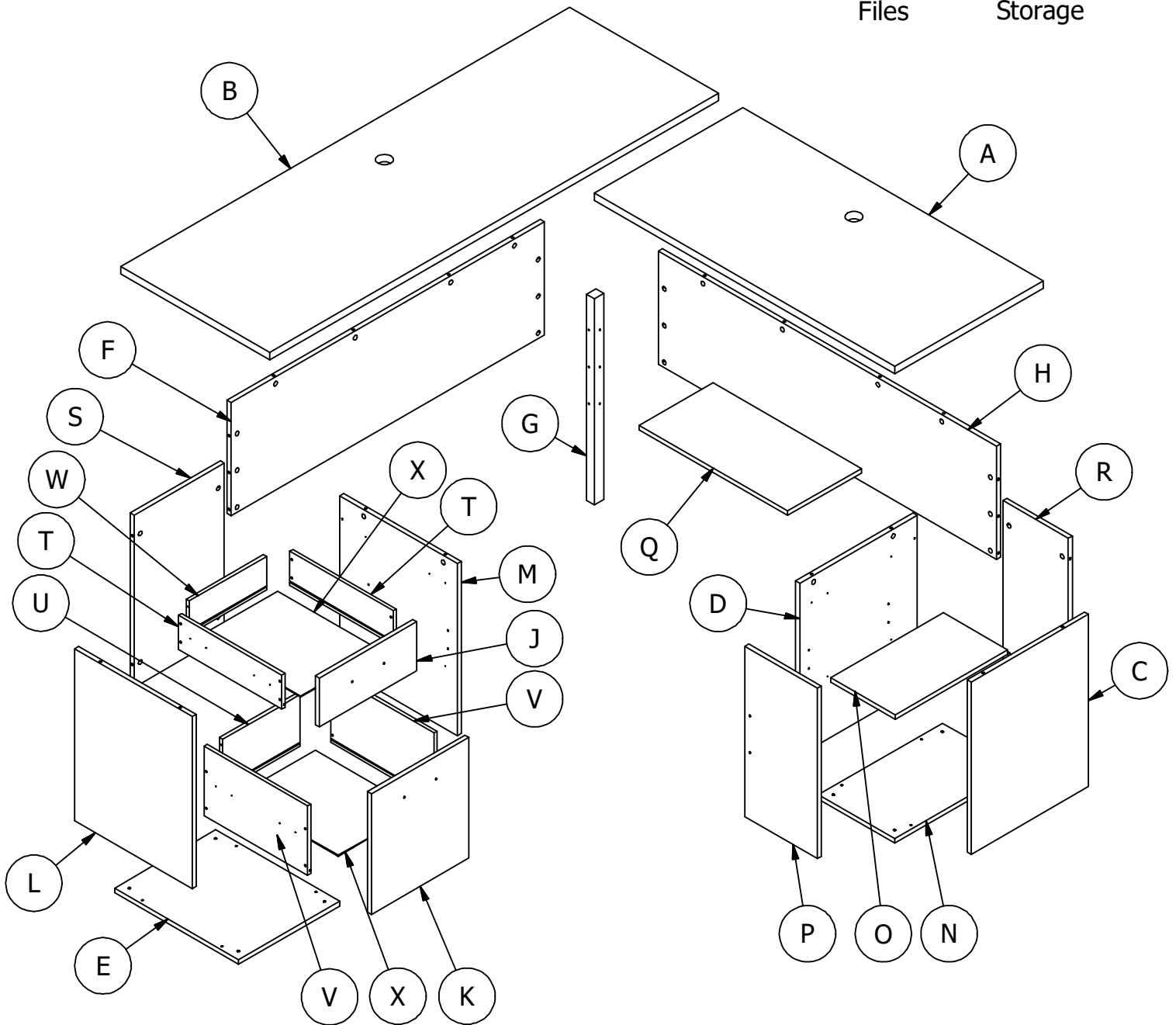
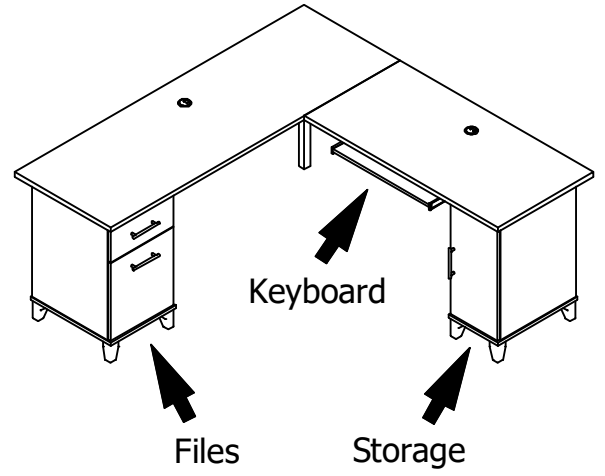

Get to know your Fasteners

Fasteners are shown actual size.

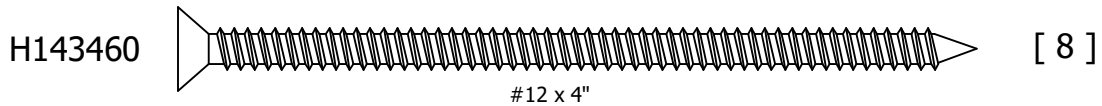
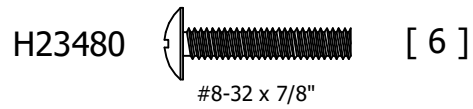
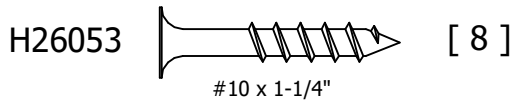
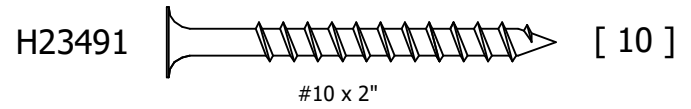
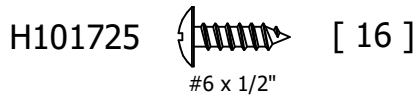
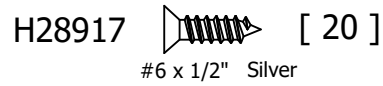
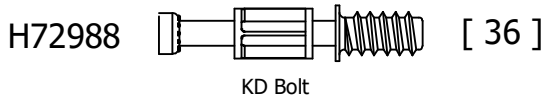
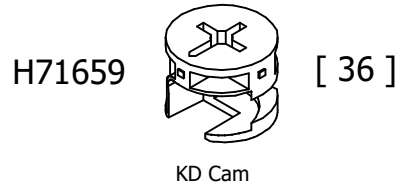
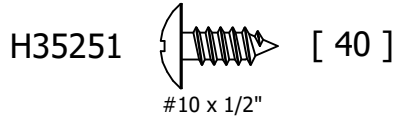

Get to know your Hardware

Hardware not to scale.

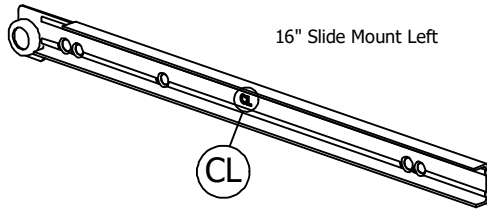

16" Slide Mount Left

[1]

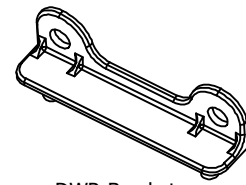

DWR Bracket

[2]

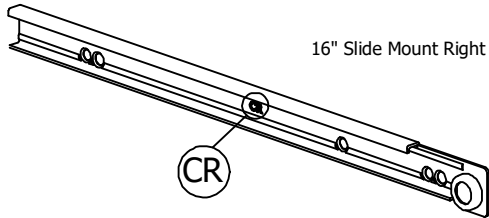

16" Slide Mount Right

[1]

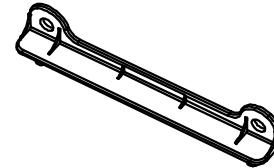

Drawer Bracket

[2]

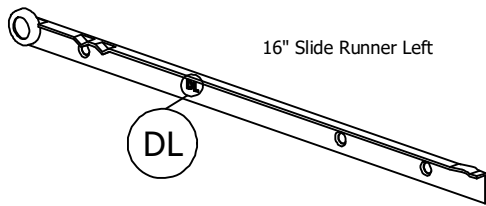

16" Slide Runner Left

[1]

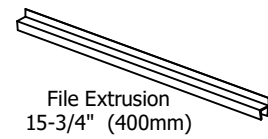

File Extrusion
15-3/4" (400mm)

[2]

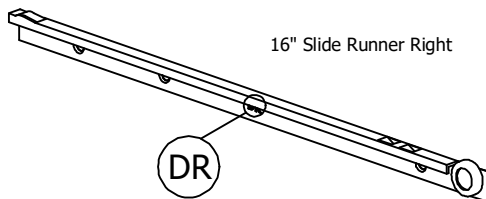

16" Slide Runner Right

[1]

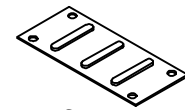

Strap

[2]

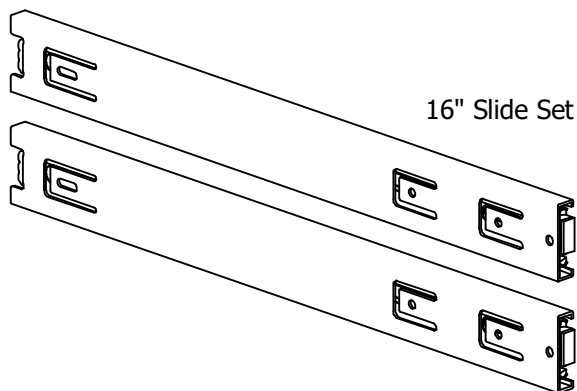

16" Slide Set

[1]

Get to know your Hardware

Hardware not to scale.

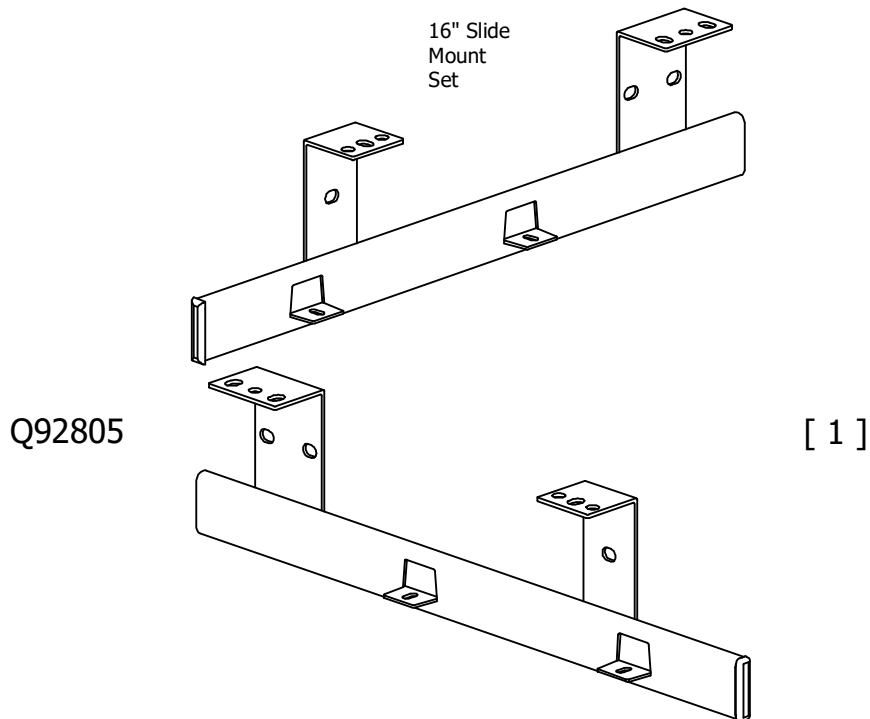
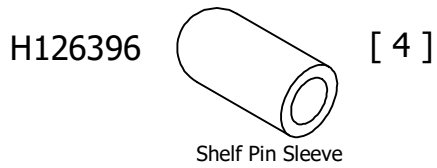
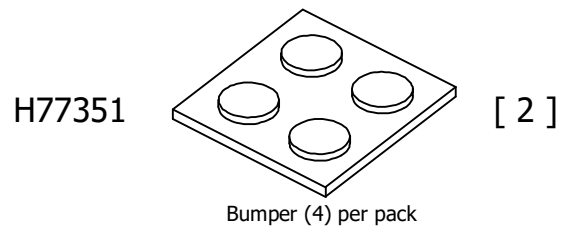
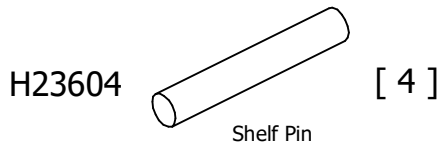
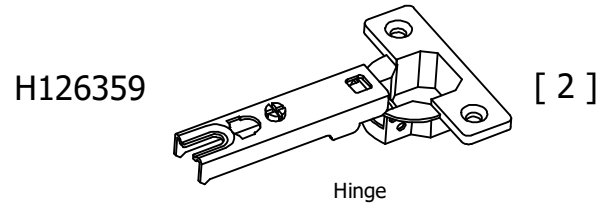
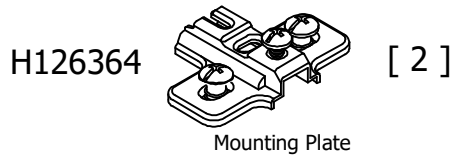

Get to know your Hardware

Hardware not to scale.

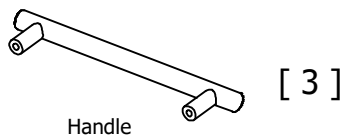
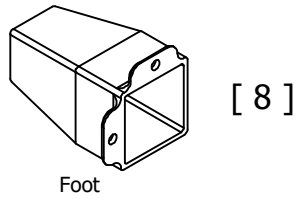
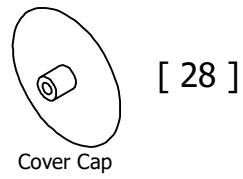
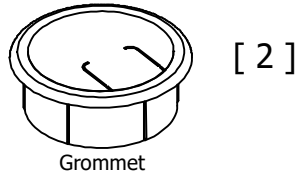

STEP 1

Prepare Drawer Fronts

H100446

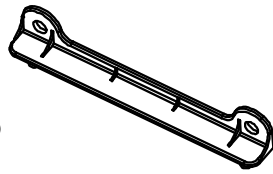

[2]

Drawer Bracket

H100445

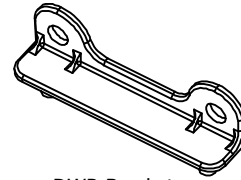

[2]

DWR Bracket

H35251

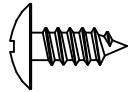

[8]

#10 x 1/2"

H100445

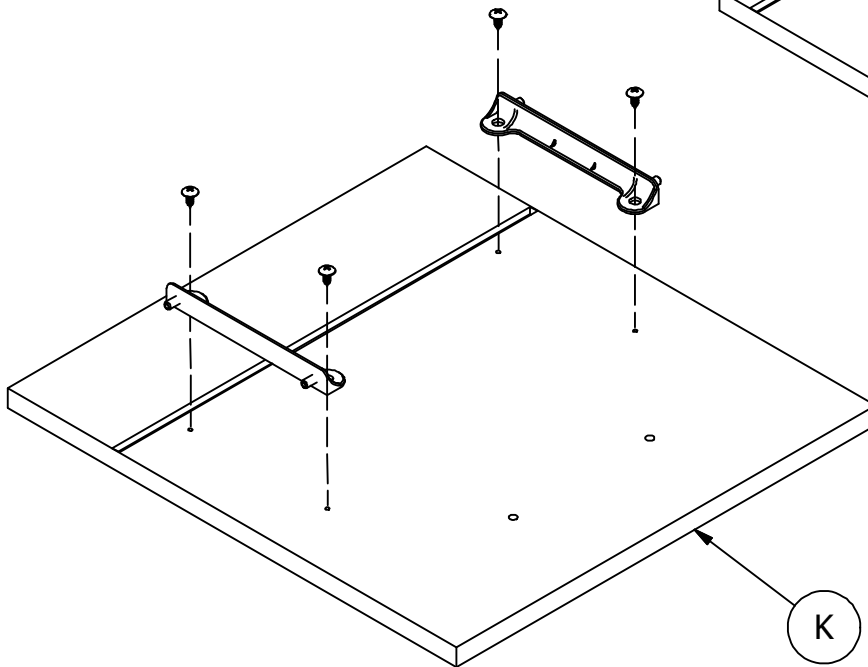
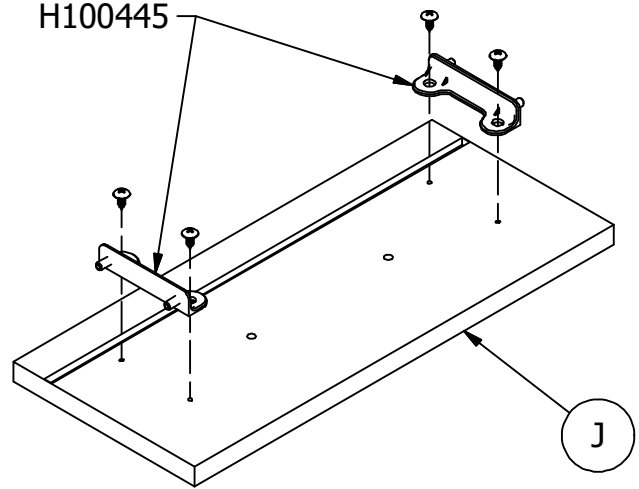

STEP 2

Build Drawer

H101725  [4]
#6 x 1/2"

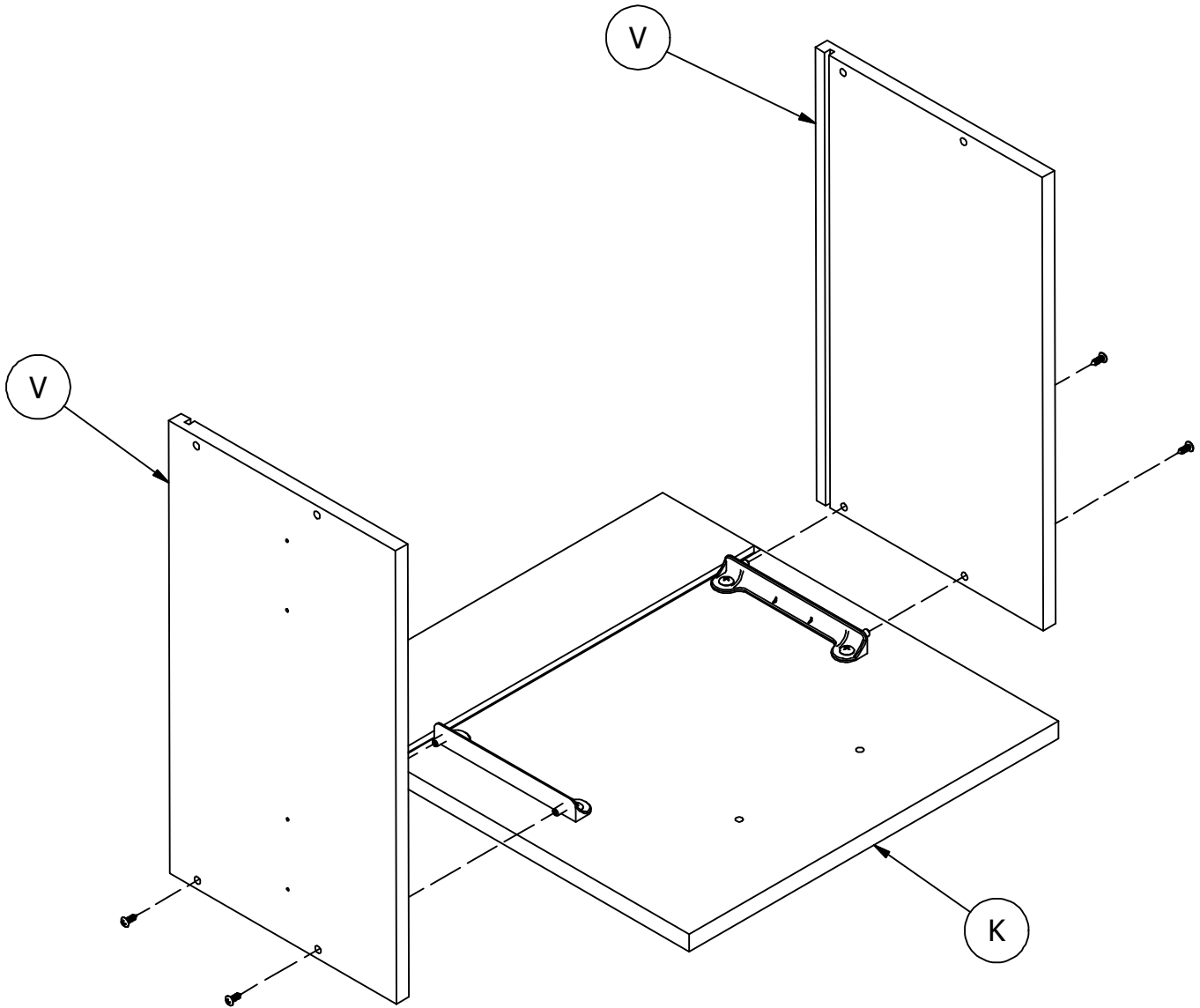

STEP 3

Build Drawer

H26053

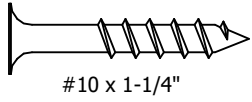

[4]

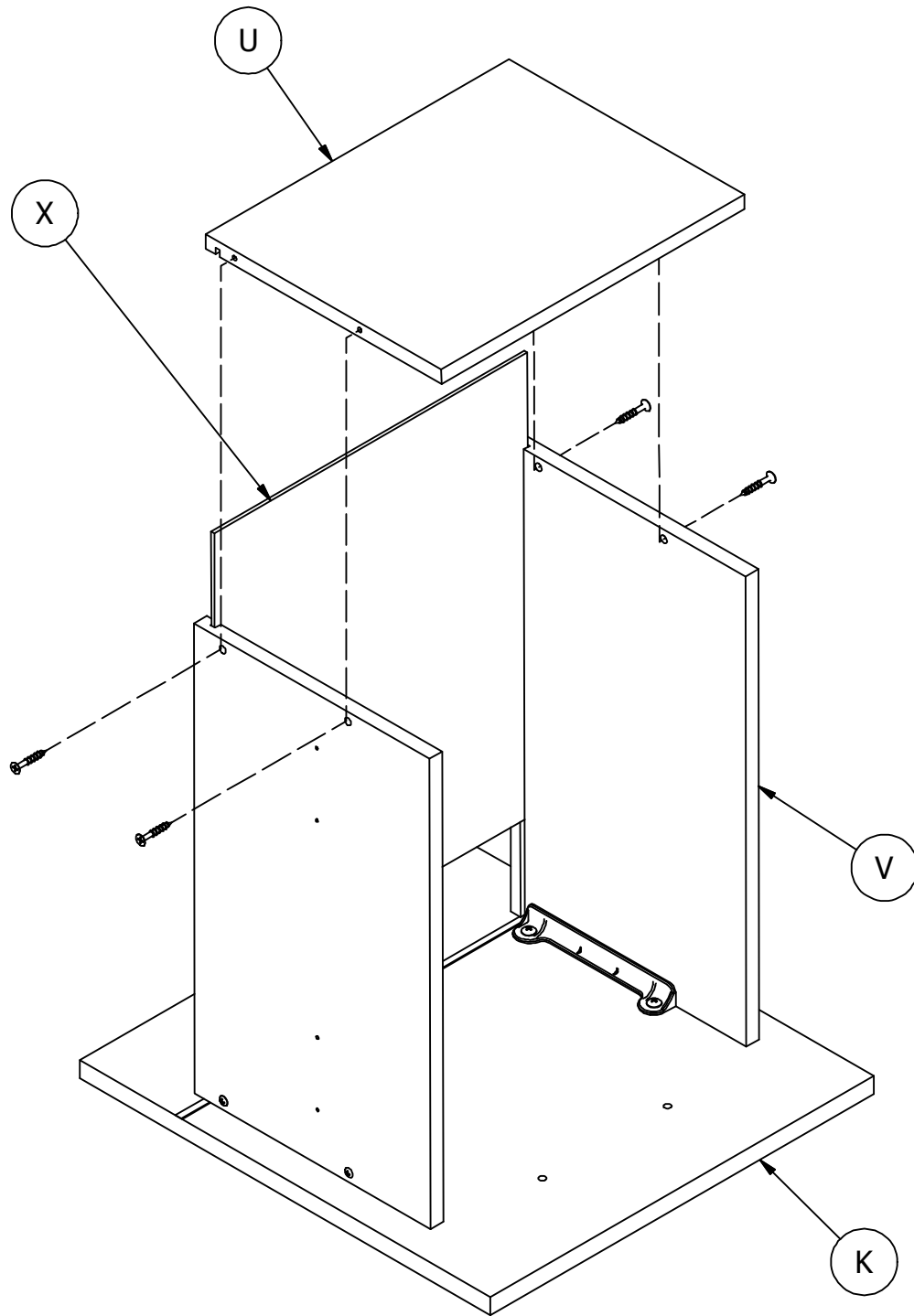

STEP 4

Separate Slides

**Slides Must Be Separated Before Assembly.
After Separated, Set Aside Until Needed for Assembly.**

Las diapositivas deben separarse antes del montaje.
Después de la separación, déjelo a un lado hasta que sea necesario.

Les glissières doivent être séparées avant l'assemblage.
Après la séparation, mettez de côté jusqu'au moment de l'assemblage.

How to Separate
and Install Drawer
Slides

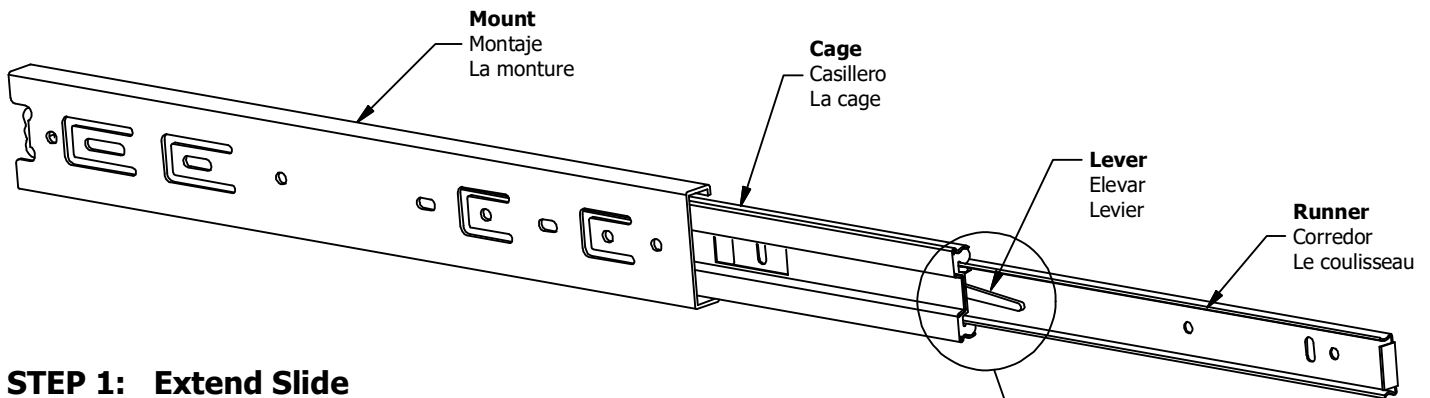

STEP 1: Extend Slide
Extender la diapositiva
Extendre la diapositive

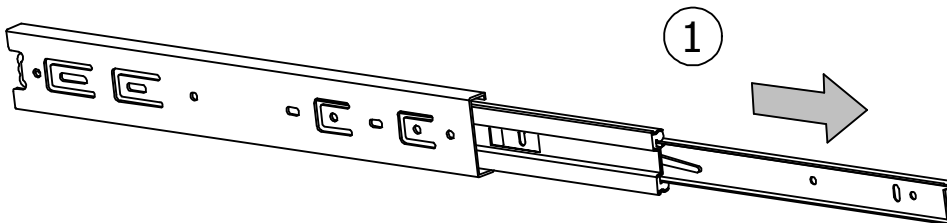

STEP 2: Push Lever UP
Empujar hacia arriba
Lever le levier

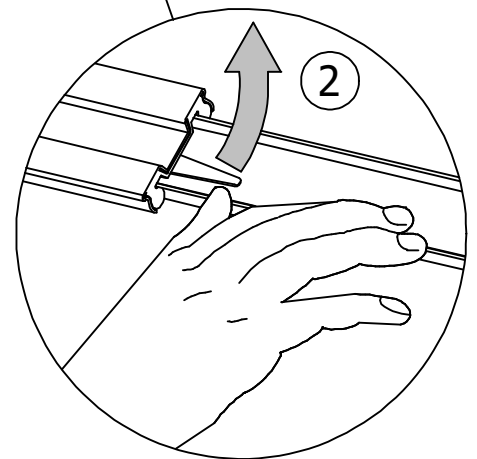

STEP 3: Remove Runner
Quitar el corredor
Enlever le coureur

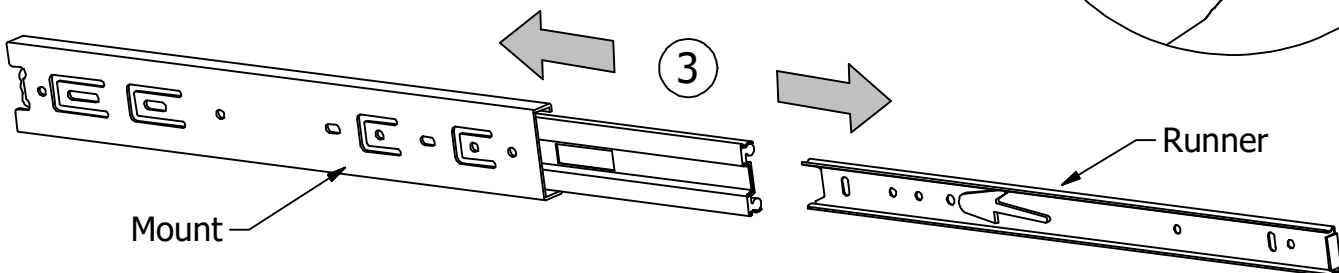

STEP 5

Build Drawer

How to Separate
and Install Drawer
Slides

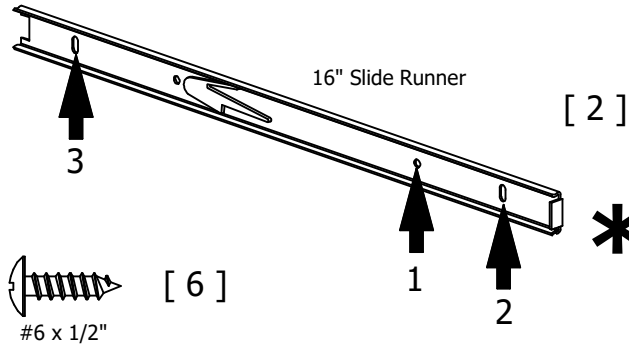

* Orientation
Orientación
L'orientation

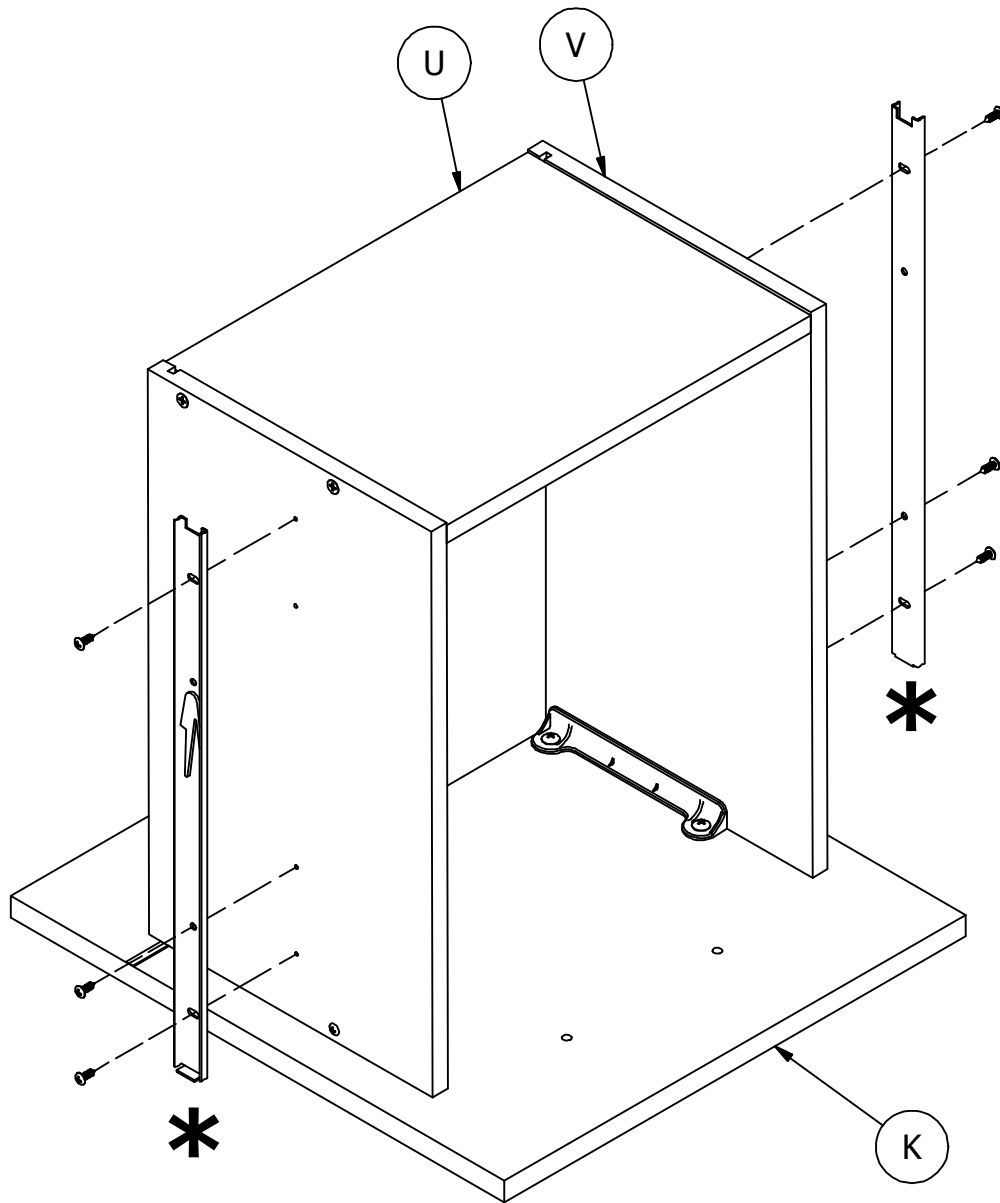

STEP 6

Build Drawer

H28917  [4]
#6 x 1/2" Silver

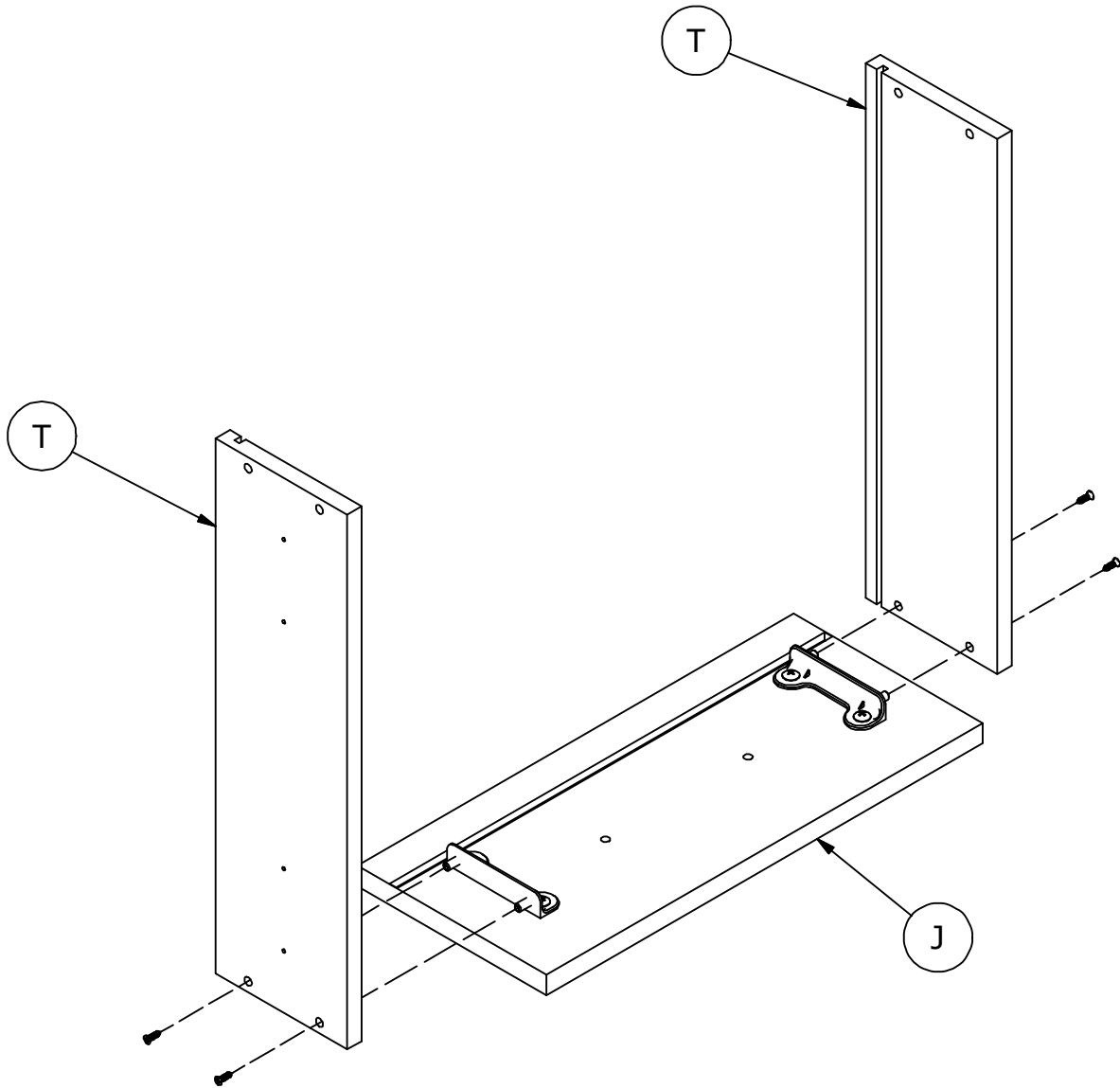

STEP 7

Build Drawer

H26053

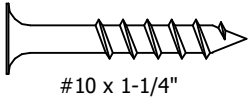

[4]

#10 x 1-1/4"

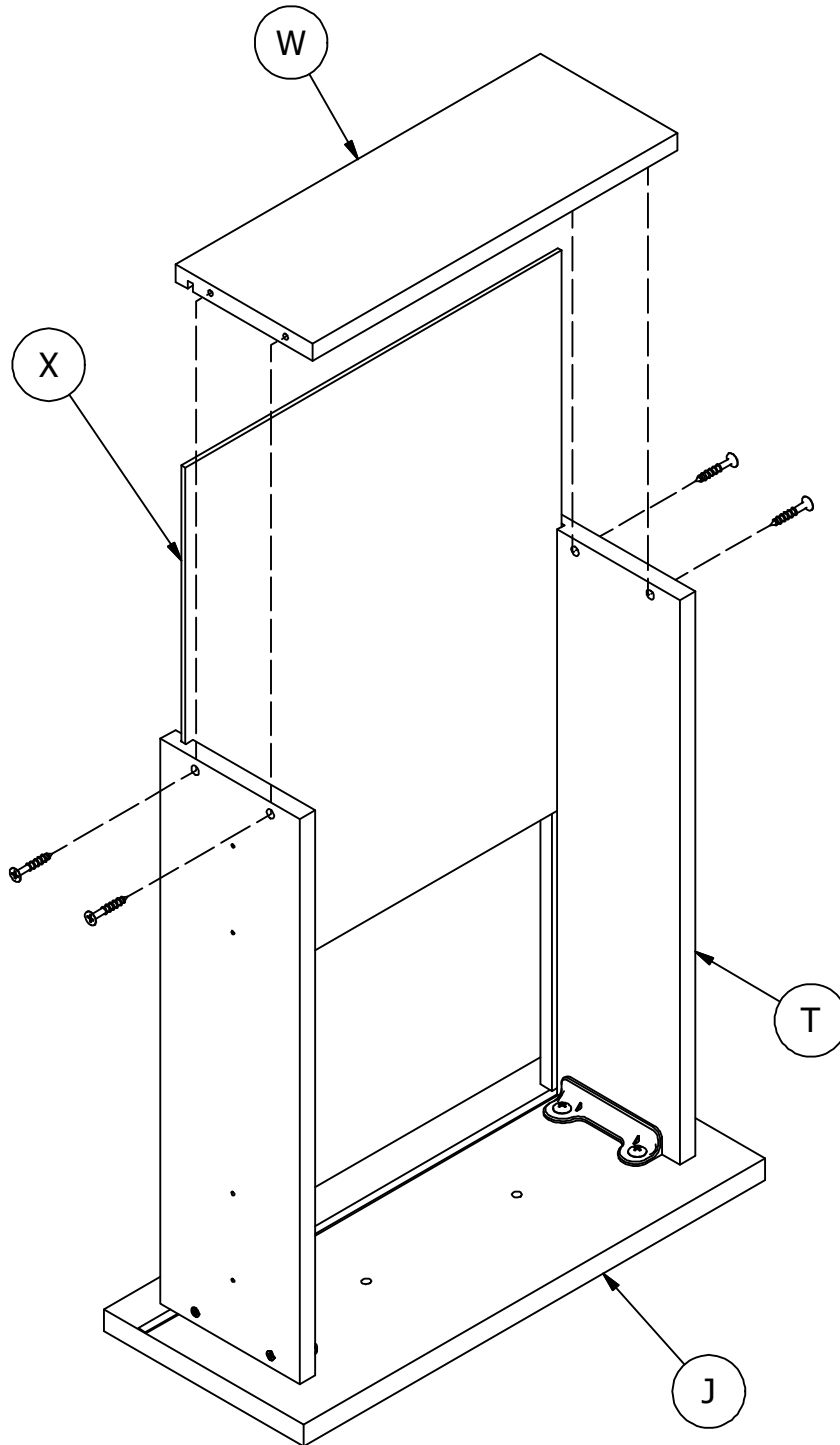

STEP 8

Build Drawer

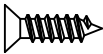
28917  [6]
#6 x 1/2" Silver

Q89897

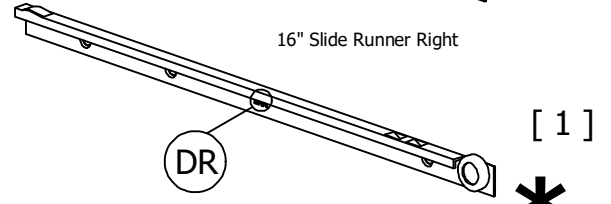
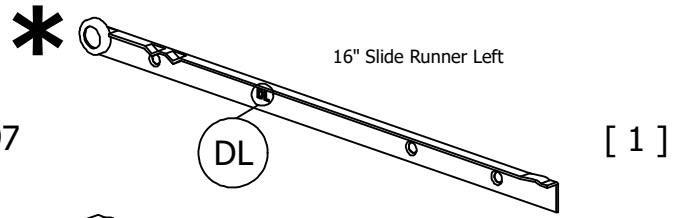

How to Separate
and Install Drawer
Slides

*
Orientation
Orientación
L'orientation

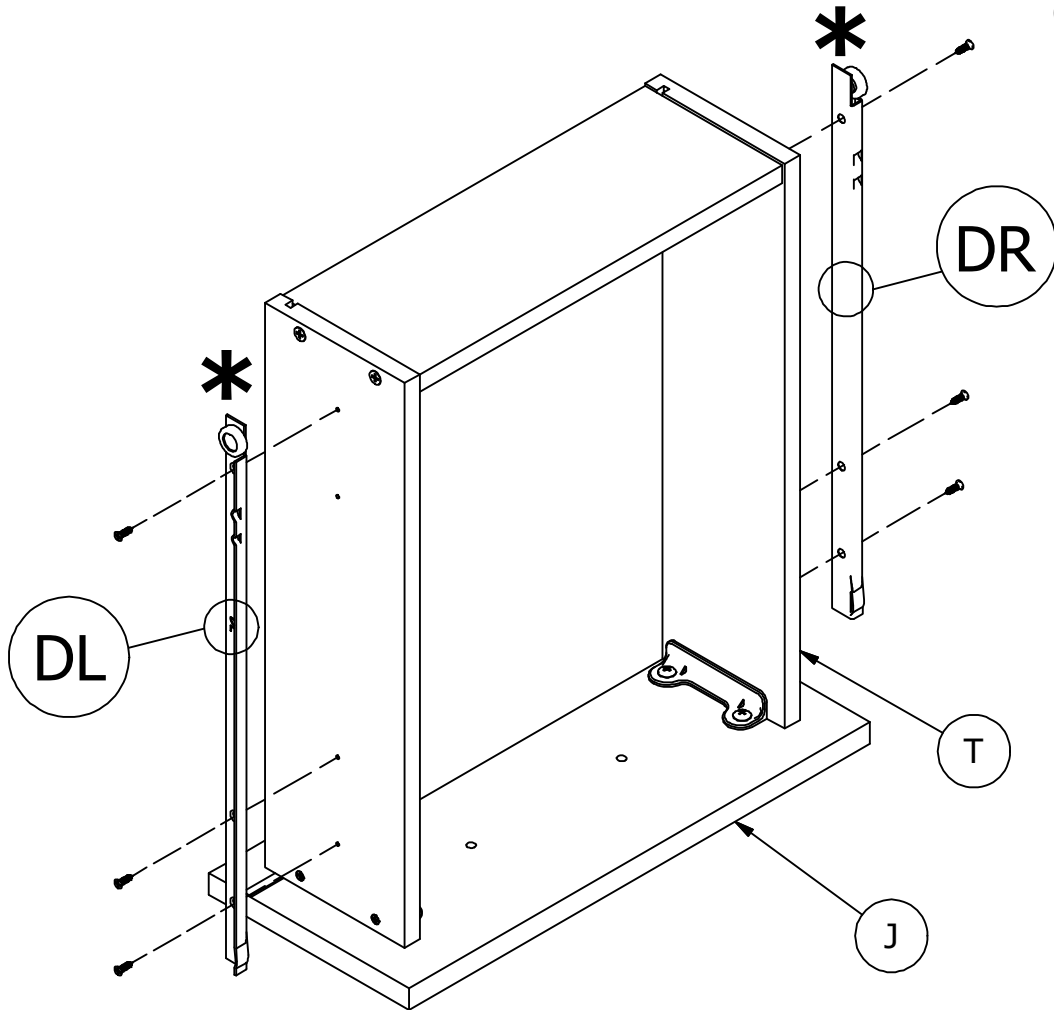

STEP 9

Build Drawers

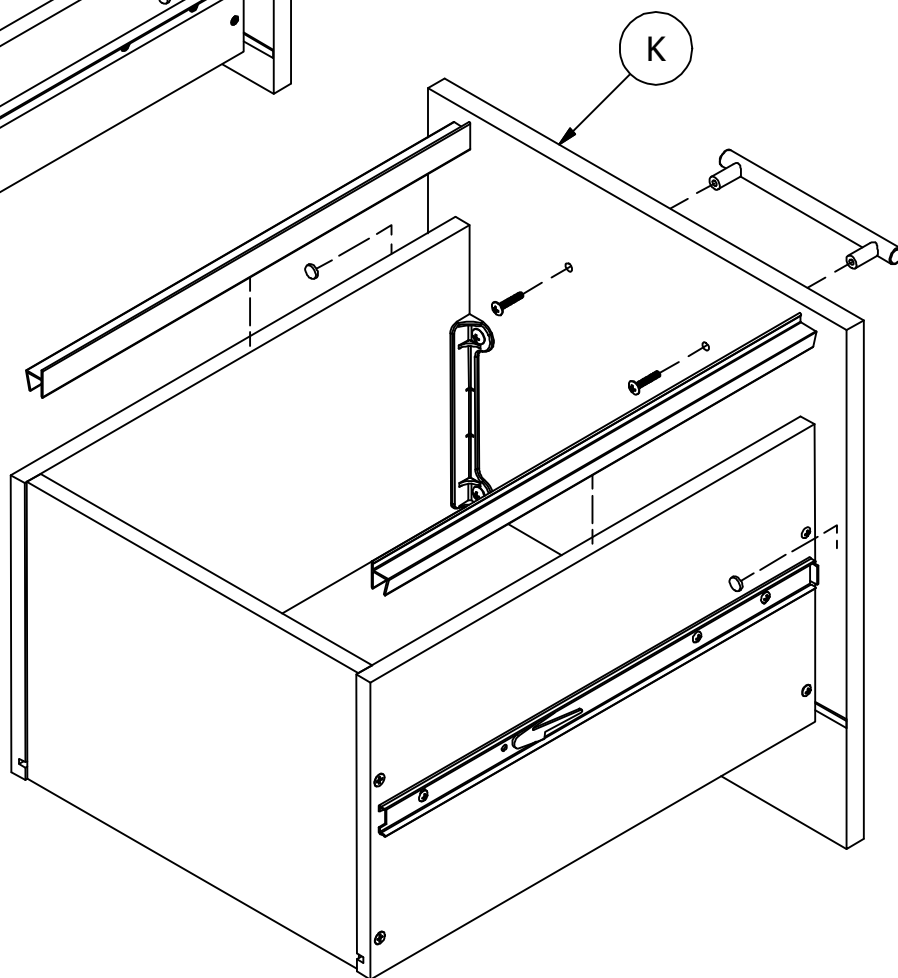
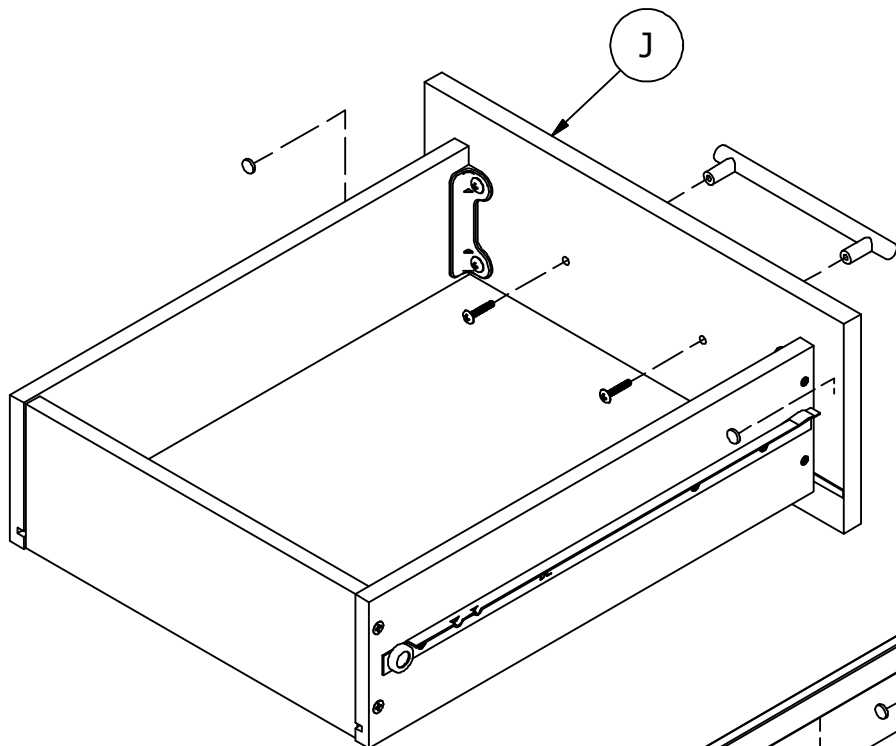
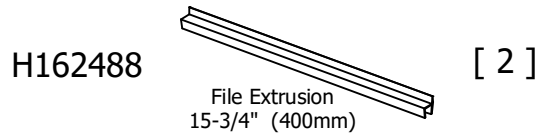
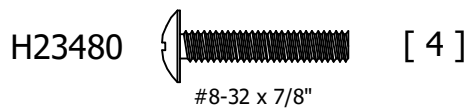
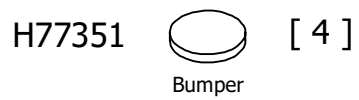
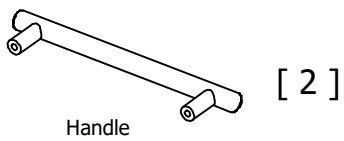

STEP 10

Prepare Door

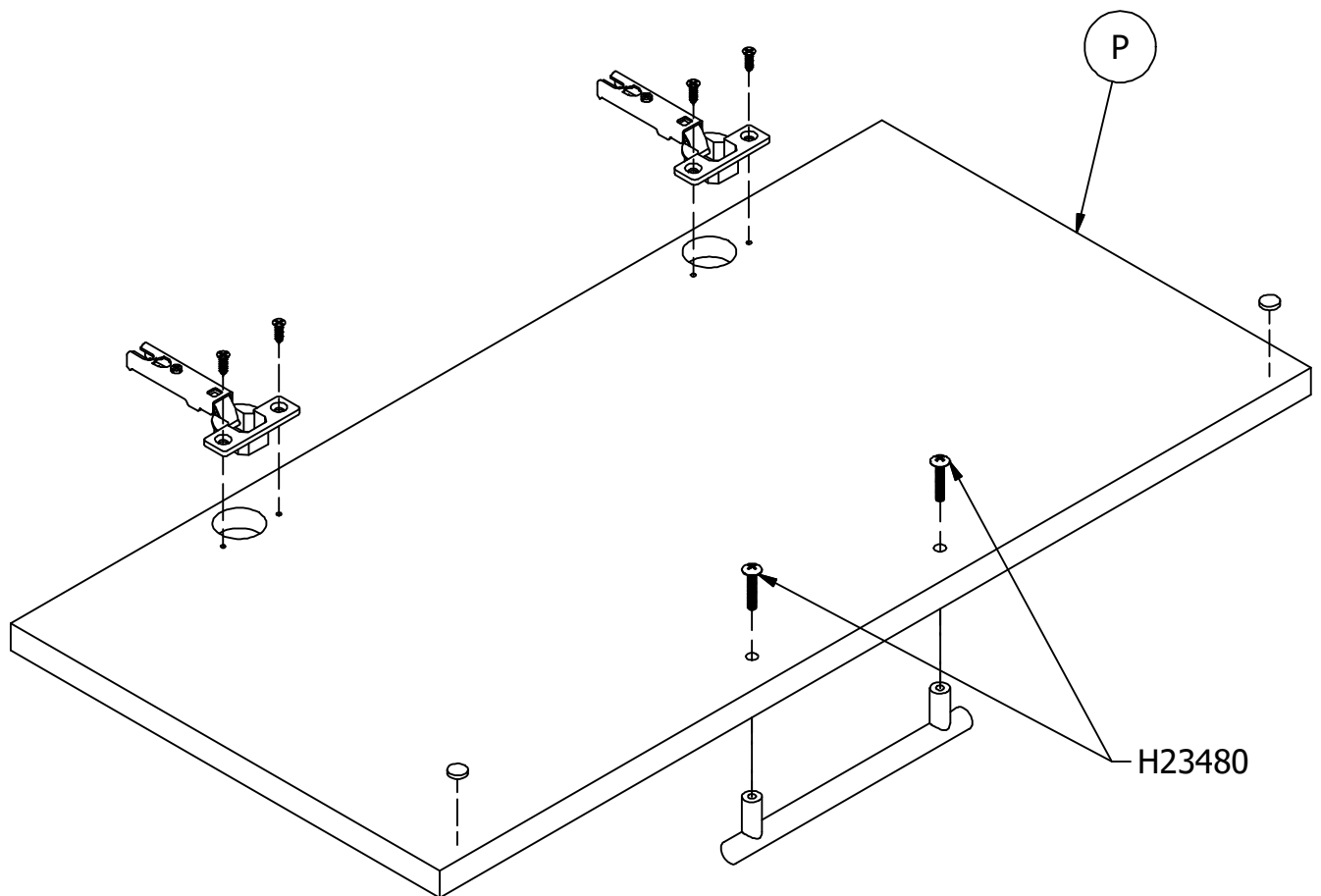
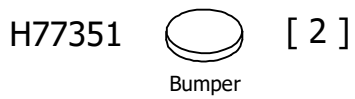
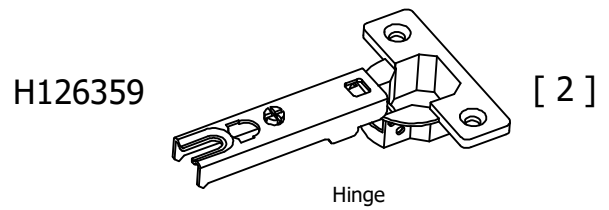
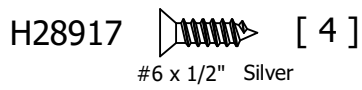
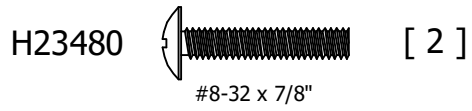
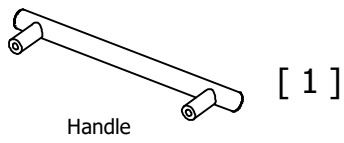

Option 1

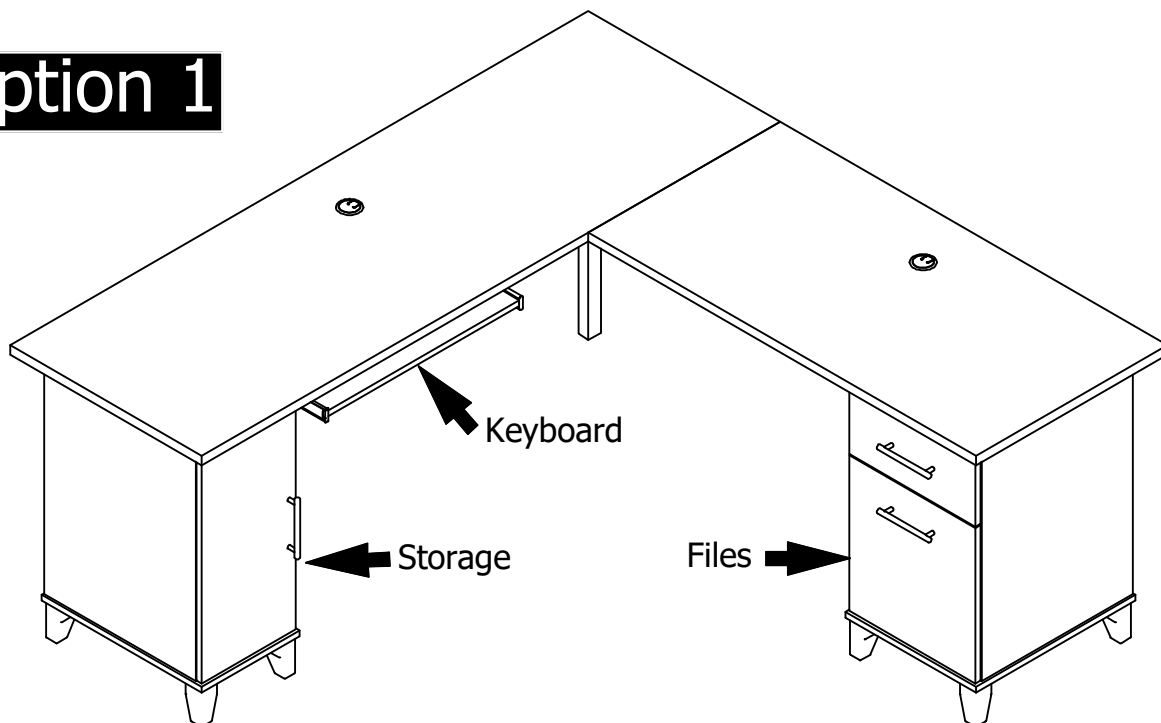

GO TO STEP 12

Option 2

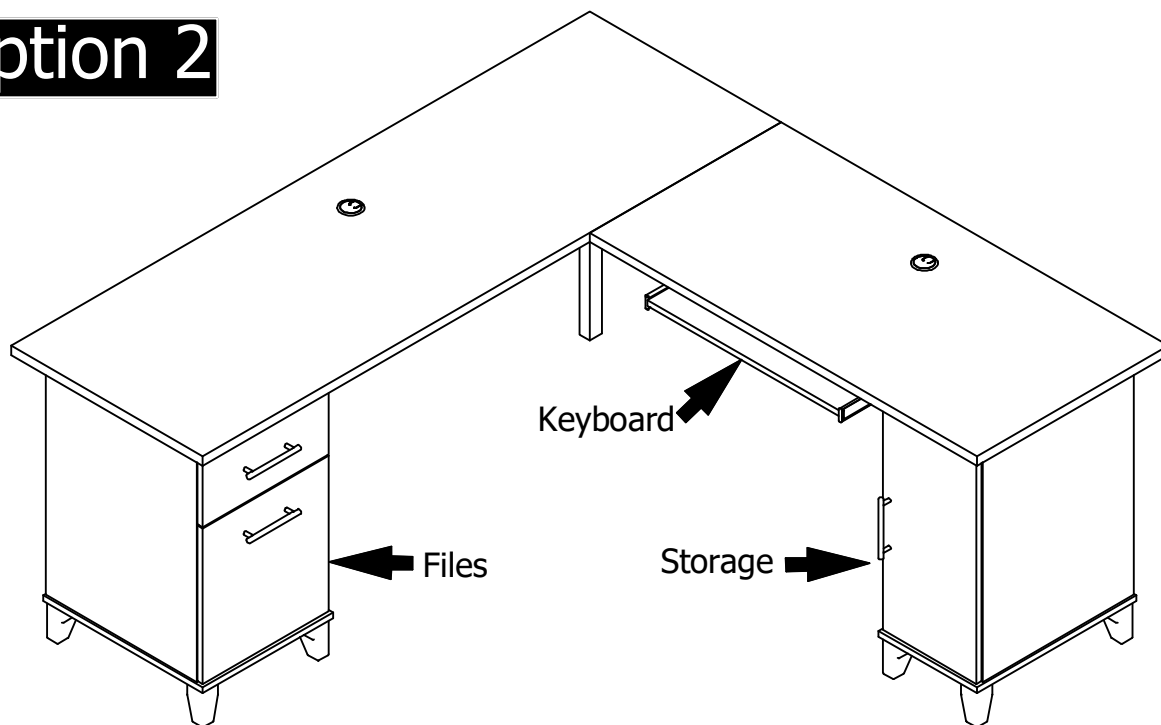

GO TO STEP 31

STEP 12

Prepare Panels

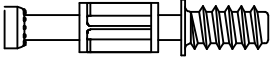
H72988  [7]
KD Bolt

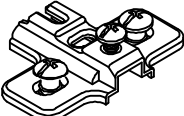
H126364  [2]
Mounting Plate

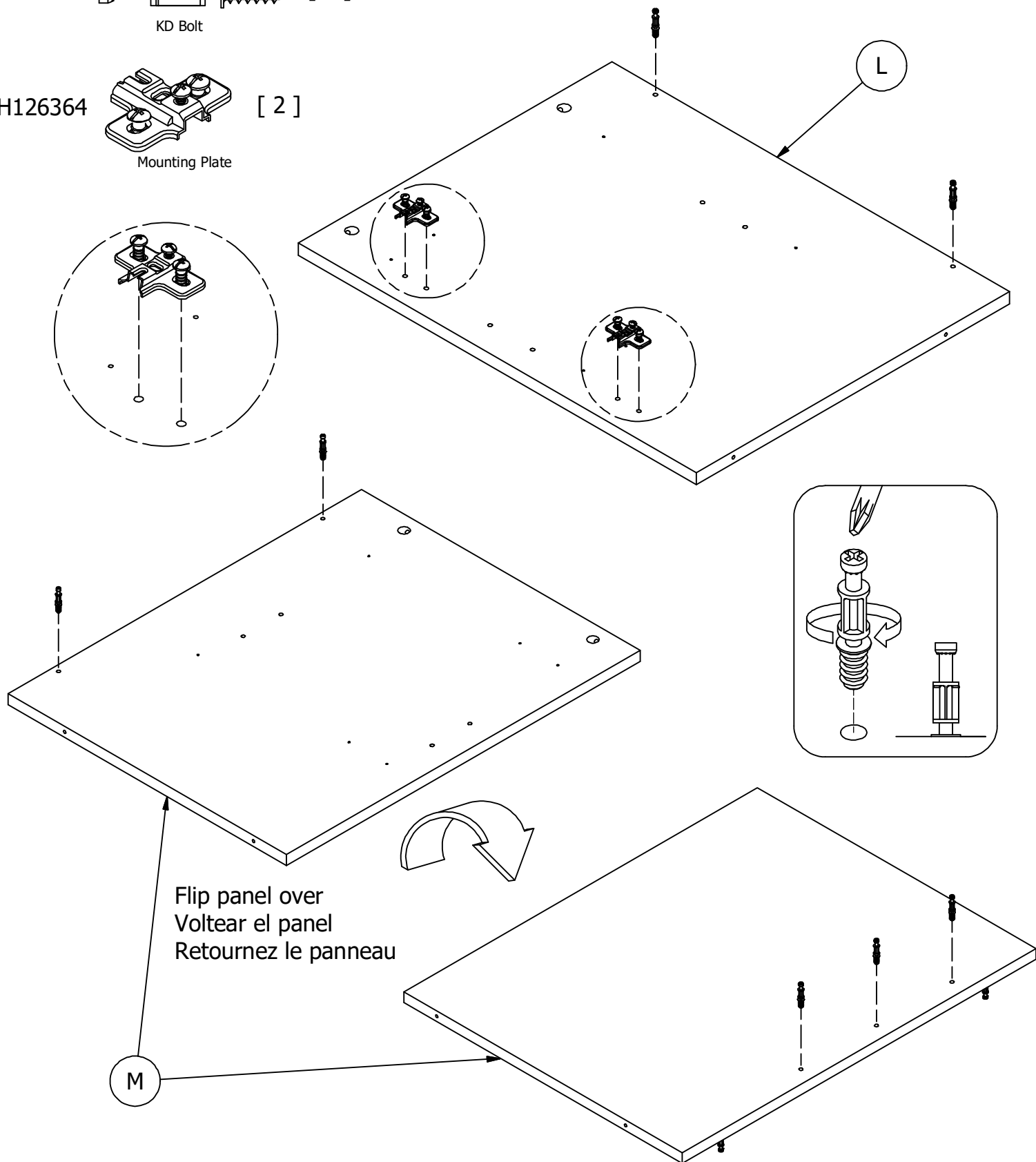

STEP 13

Assemble Panels

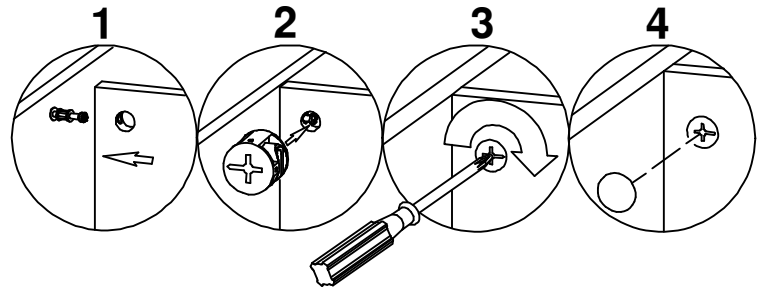
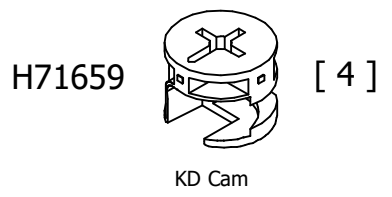

How to Tighten
KD Cams

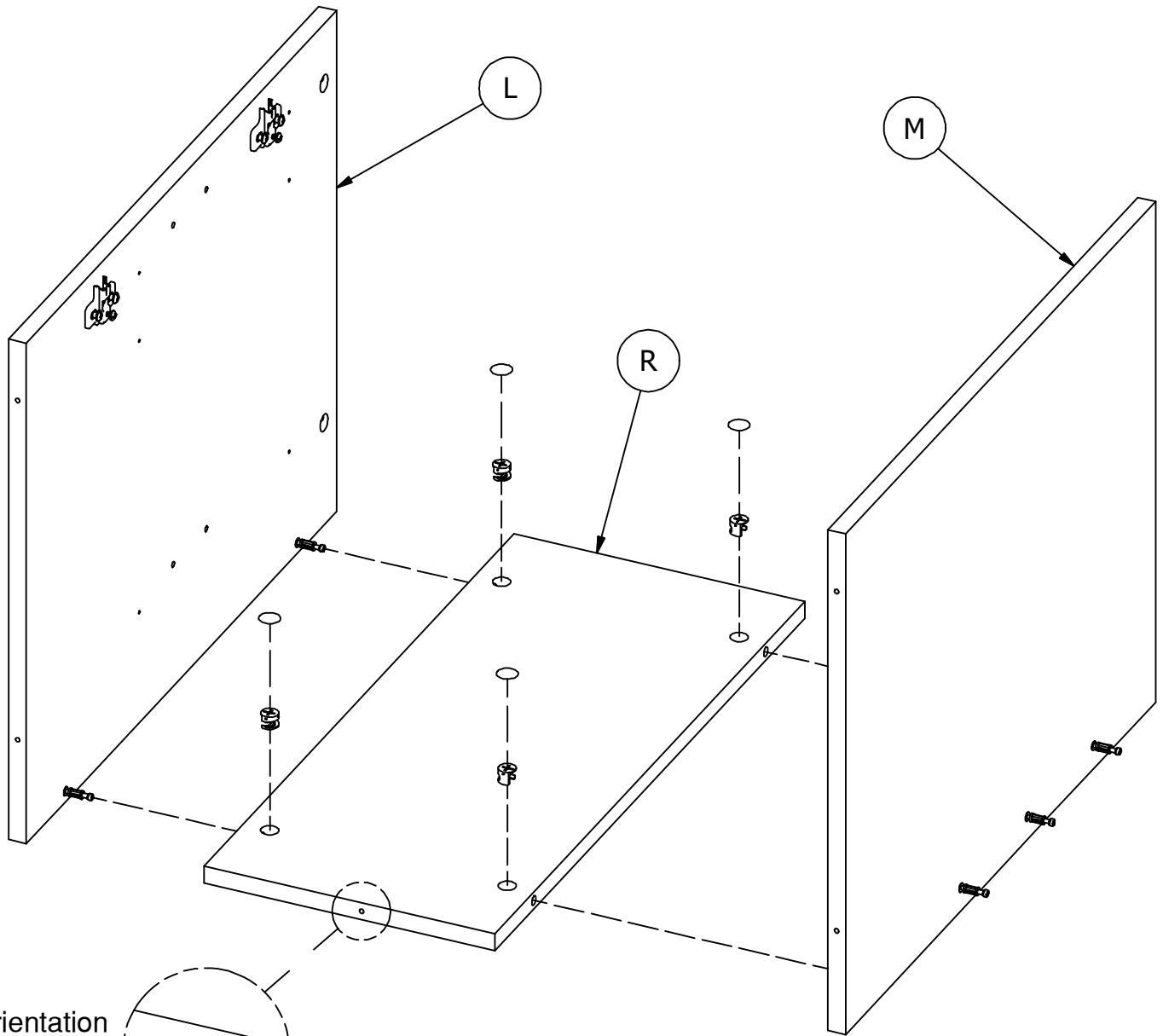
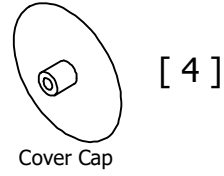

Orientation
Orientación
L'orientation

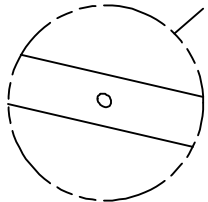

STEP 14

Prepare Panel

H143460

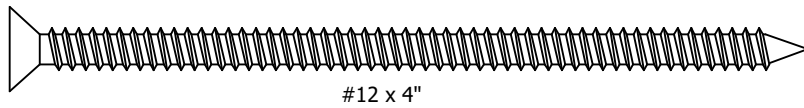

[4]

#12 x 4"

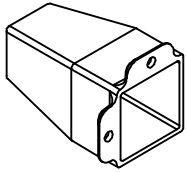

[4]

Foot

H35251

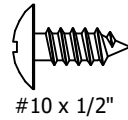

[8]

#10 x 1/2"

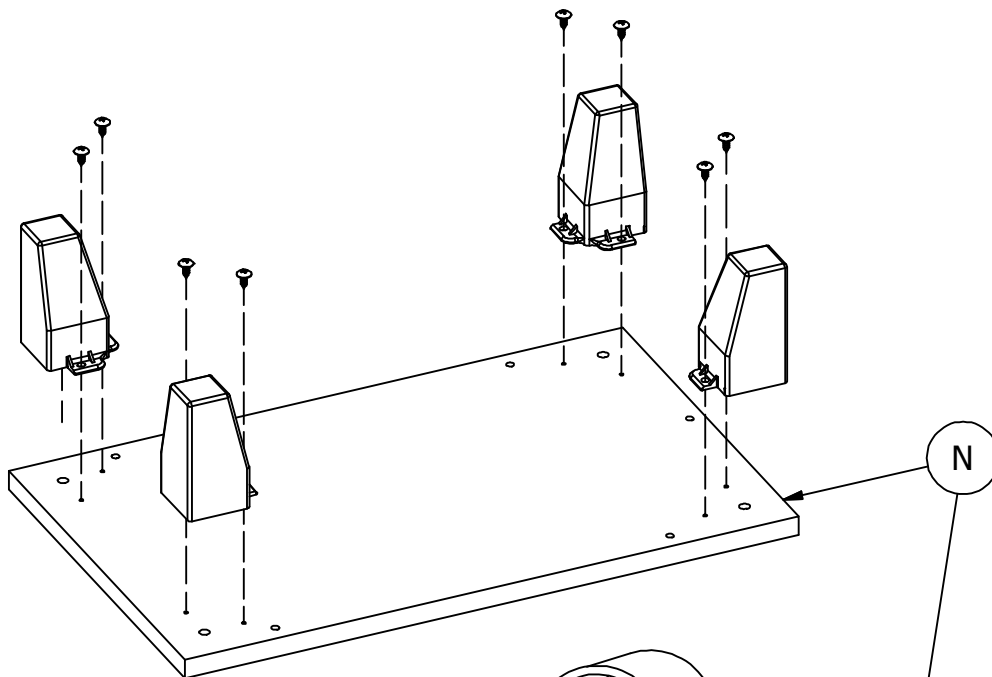

Flip panel over
Voltear el panel
Retournez le panneau

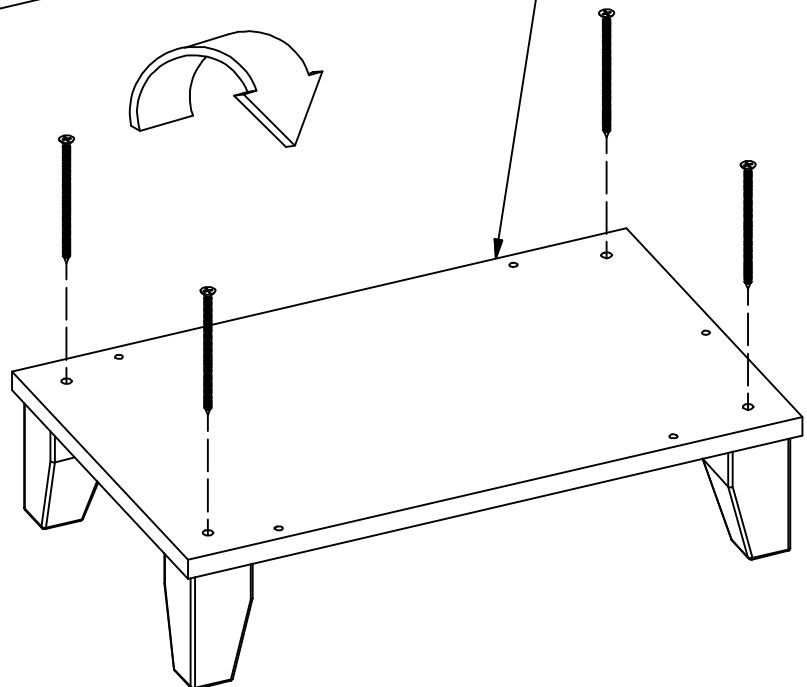

STEP 15

Assemble Panels

H23491

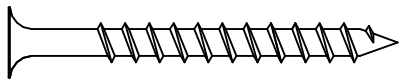

[5]

#10 x 2"

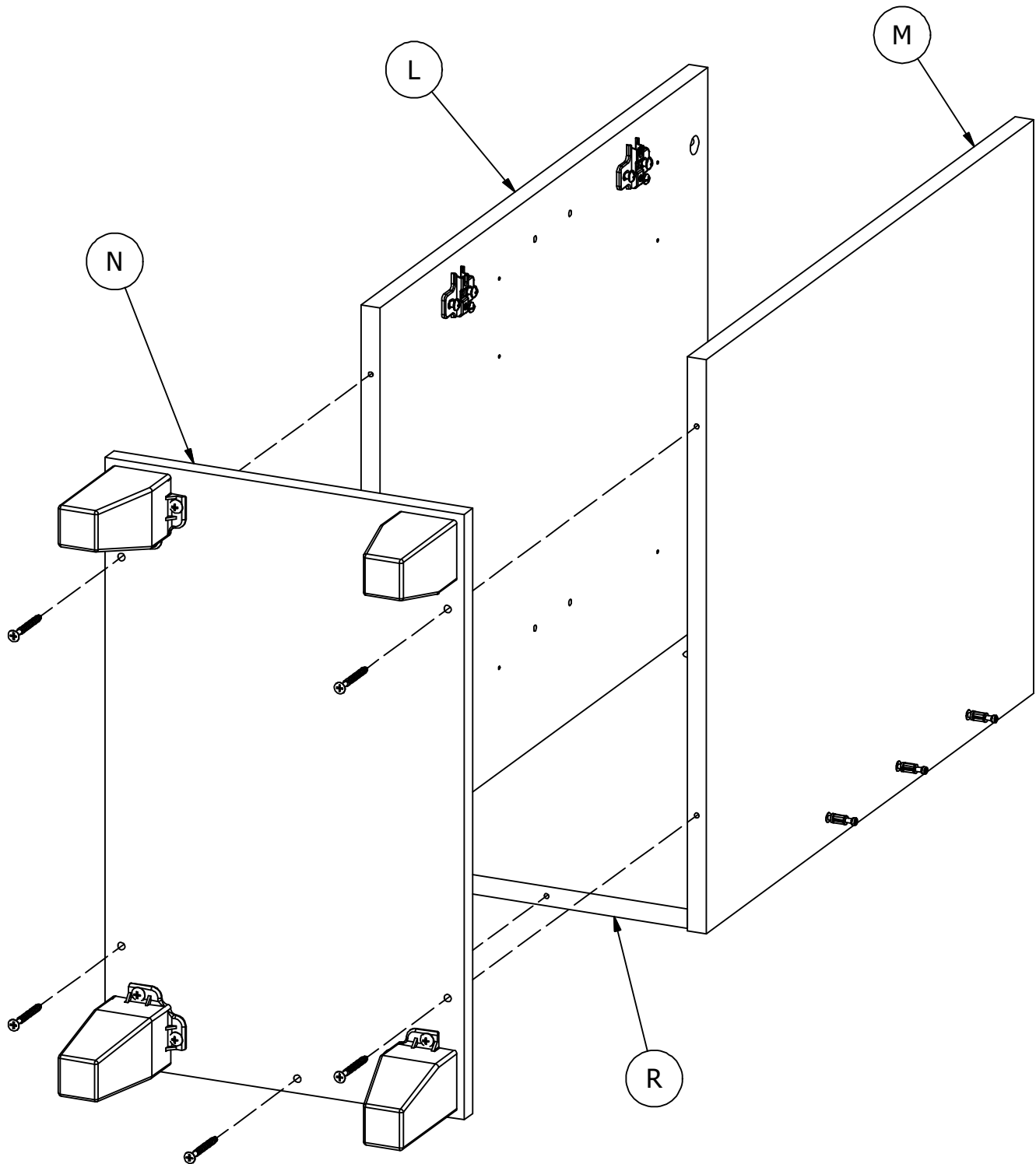

STEP 16

Prepare Panel

H28917  [3]
#6 x 1/2" Silver

H101725  [3]
#6 x 1/2"

How to Separate
and Install Drawer
Slides

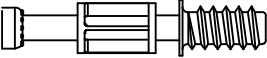
H72988  [2]
KD Bolt

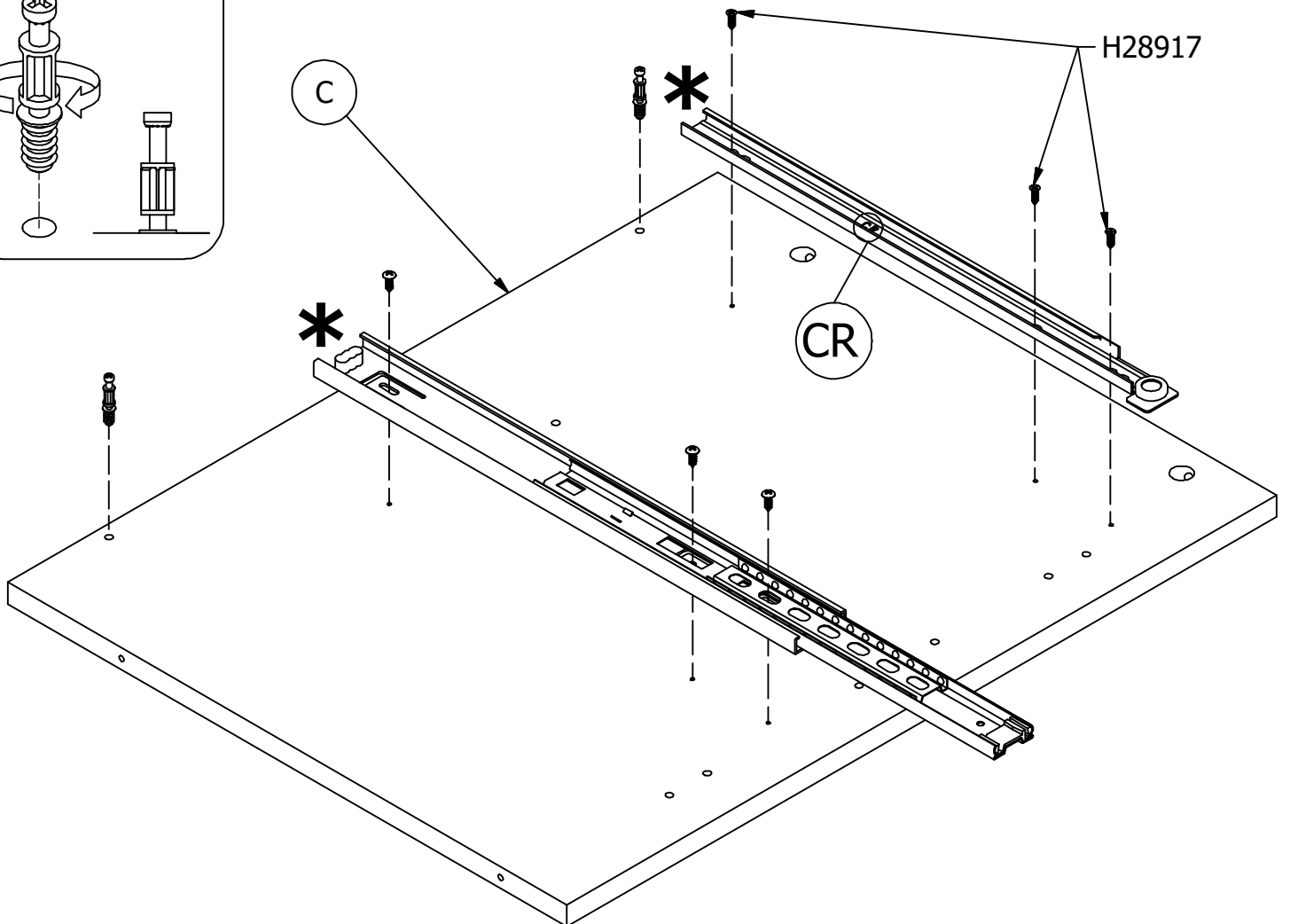
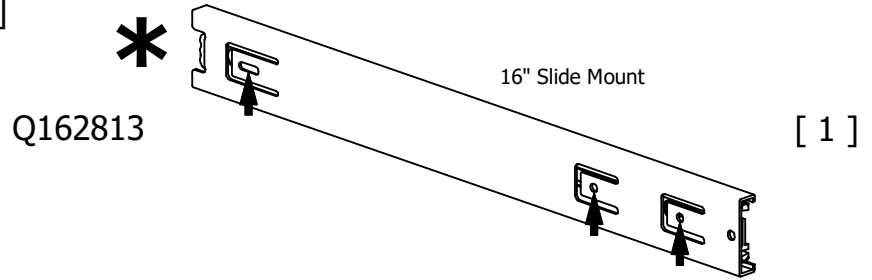
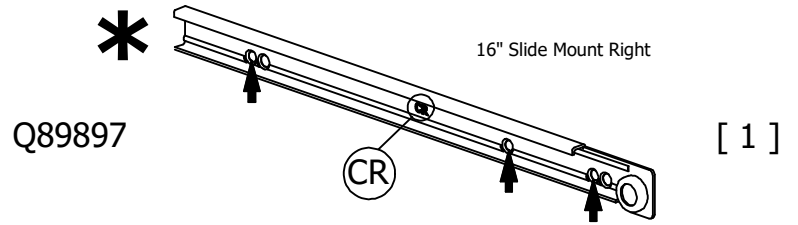
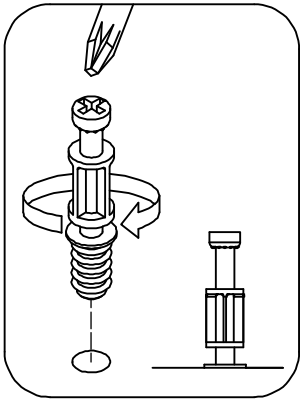

STEP 17

Prepare Panel

H28917  [3]
#6 x 1/2" Silver

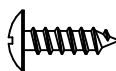
H101725  [3]
#6 x 1/2"

How to separate
and install Drawer
Slides

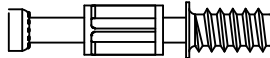
H72988  [2]
KD Bolt

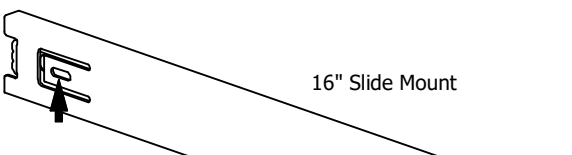
*****  16" Slide Mount [1]
Q162813

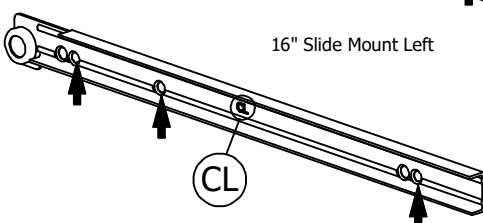
 16" Slide Mount Left [1]
Q89897 *****

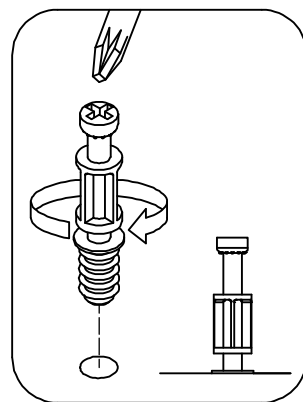
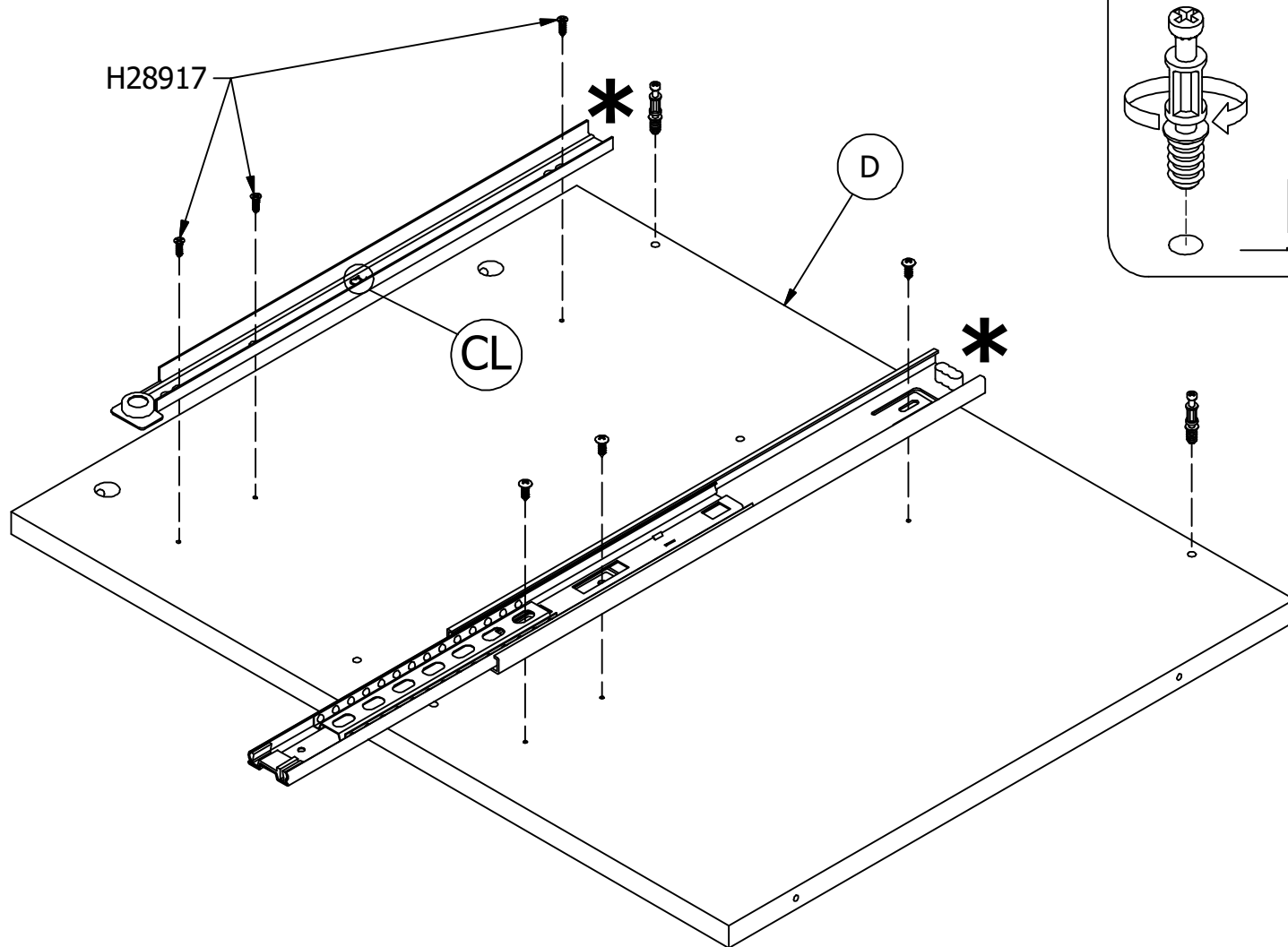

STEP 18

Prepare Panel

H72988 [3]
KD Bolt

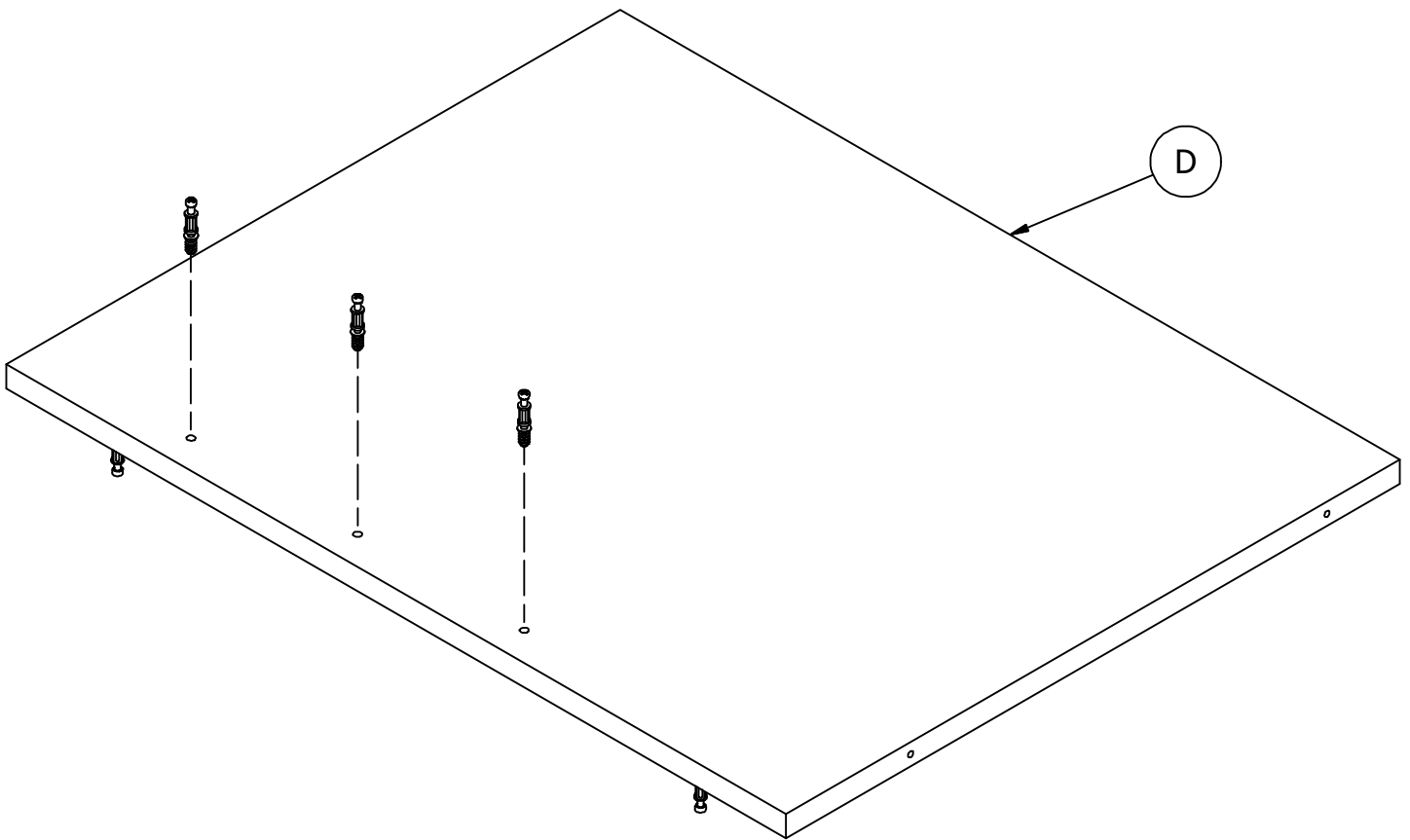
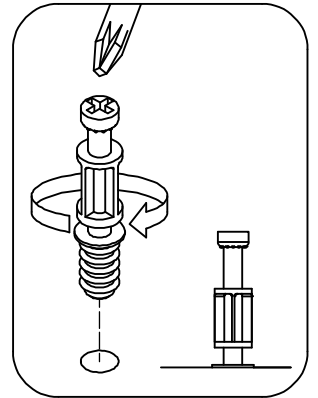

STEP 19

Assemble Panels

H71659

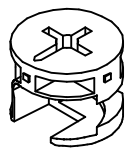

[4]

KD Cam

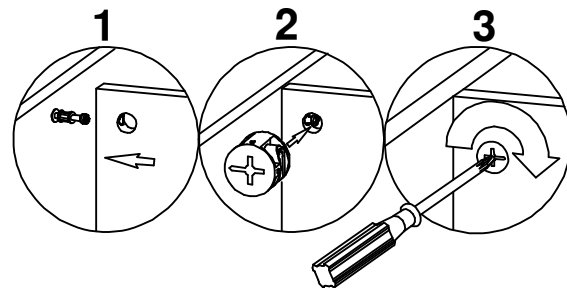

How to tighten
KD Cams

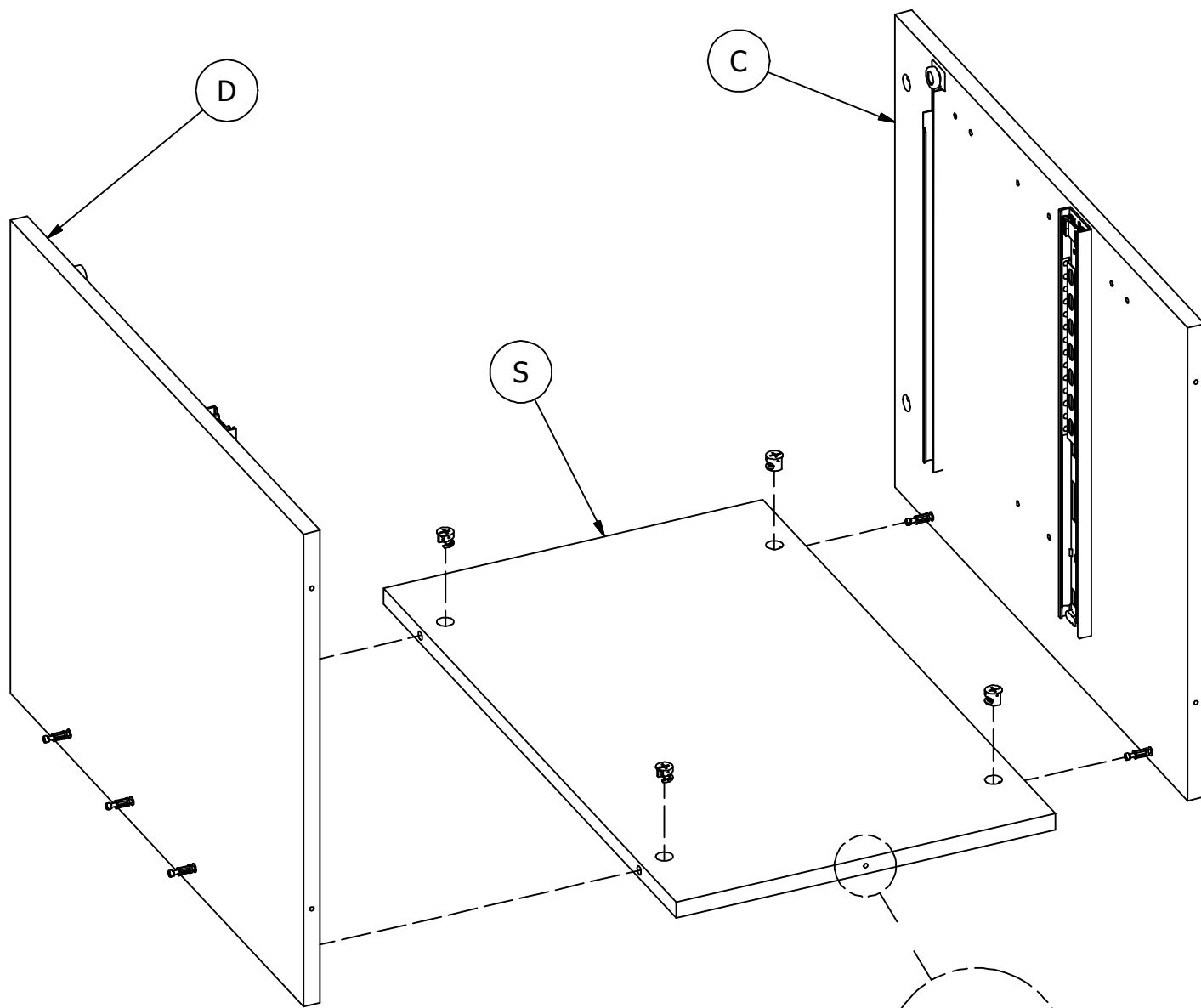

Orientation
Orientación
L'orientation

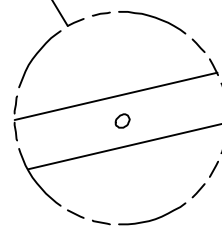

STEP 20

Prepare Panel

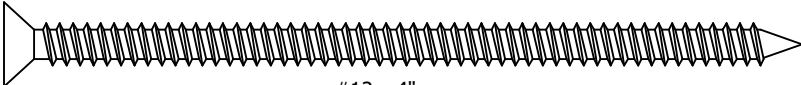
H143460  [4]
#12 x 4"

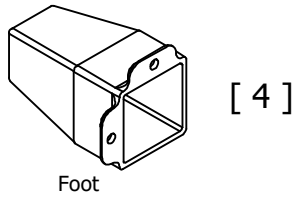

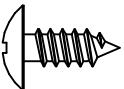
H35251  [8]
#10 x 1/2"

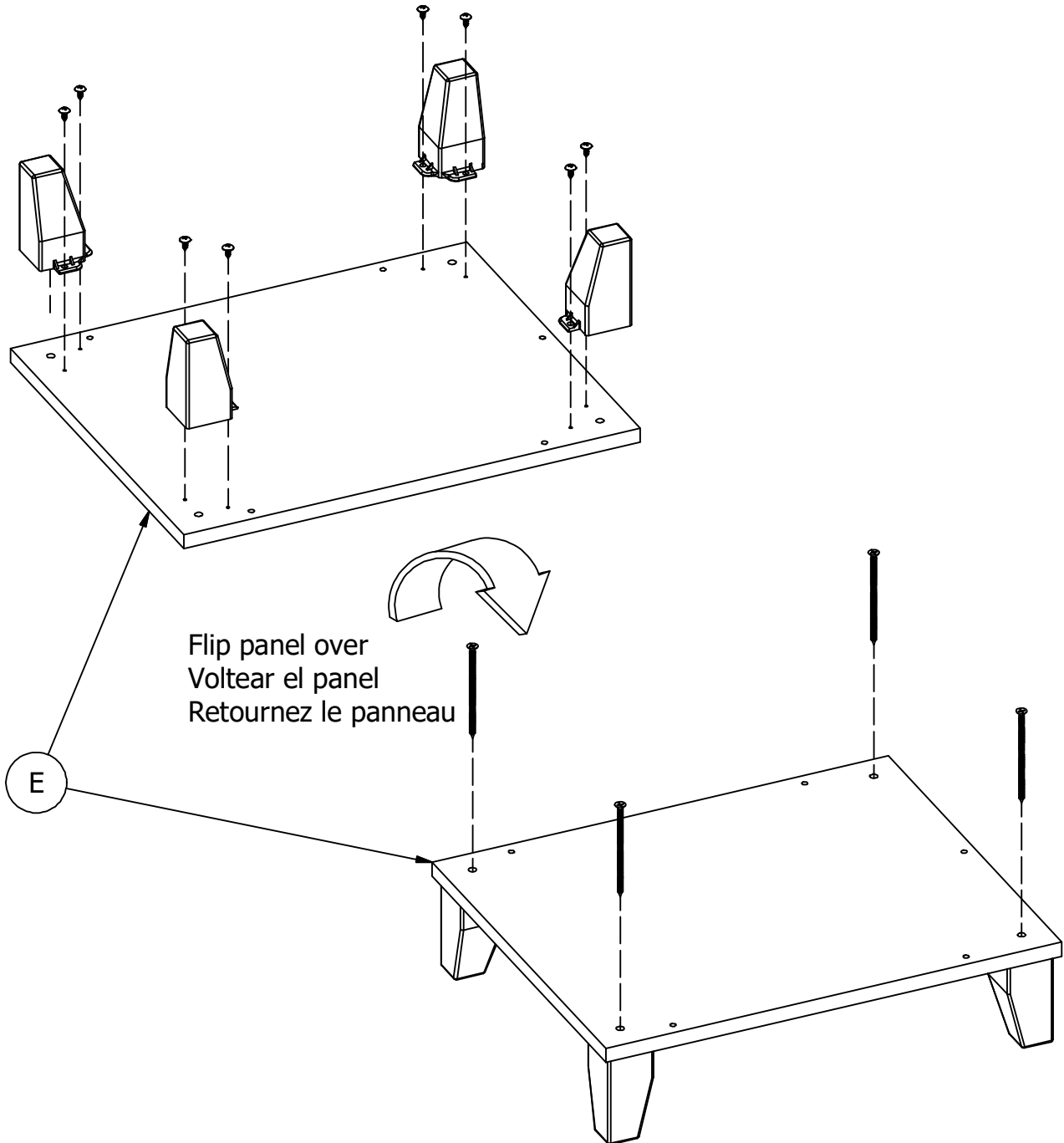

STEP 21

Assemble Panels

H23491

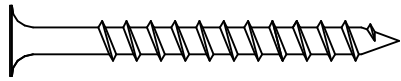

[5]

#10 x 2"

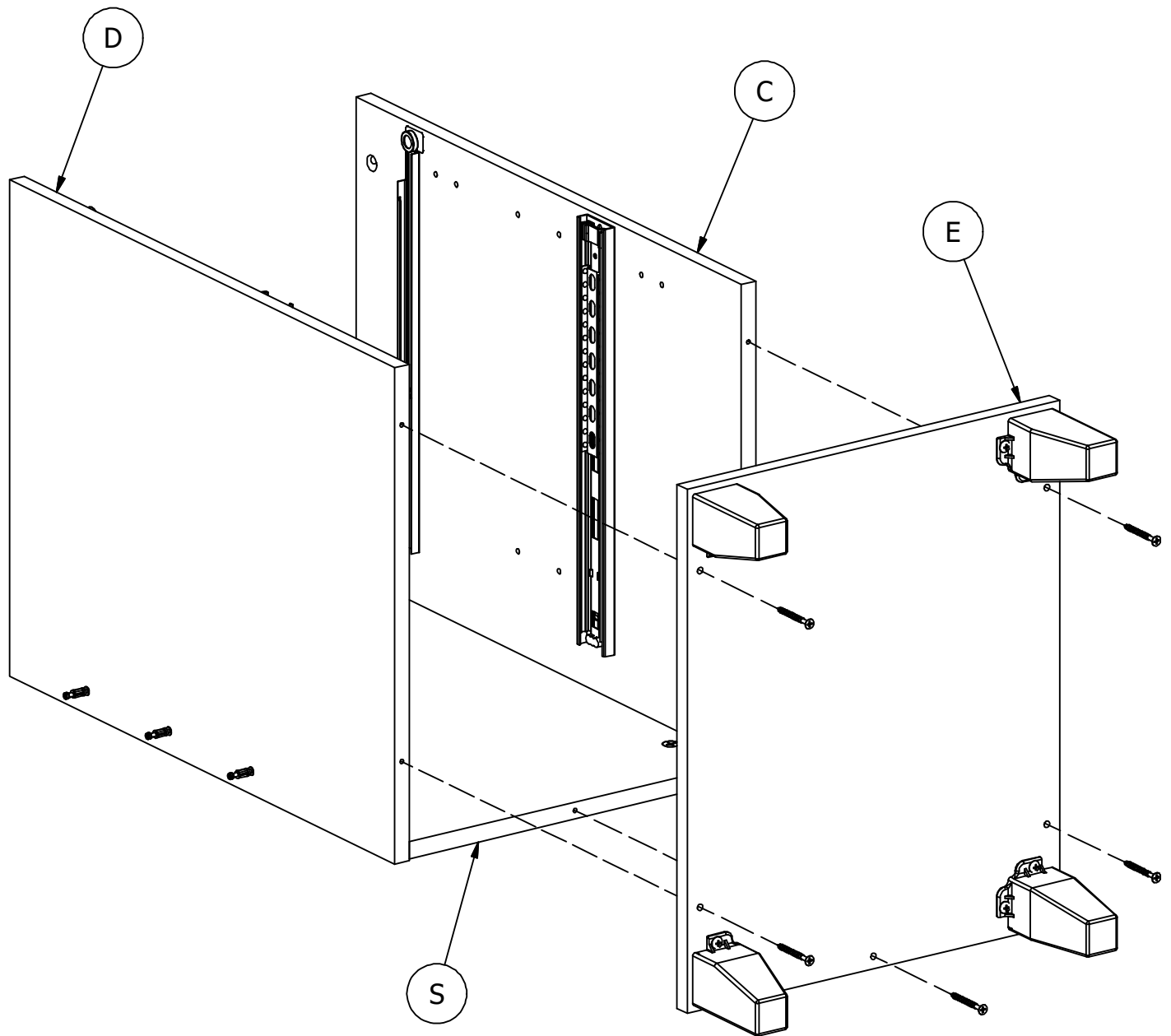

STEP 22

Prepare Rear Leg

H72988 [6]
KD Bolt

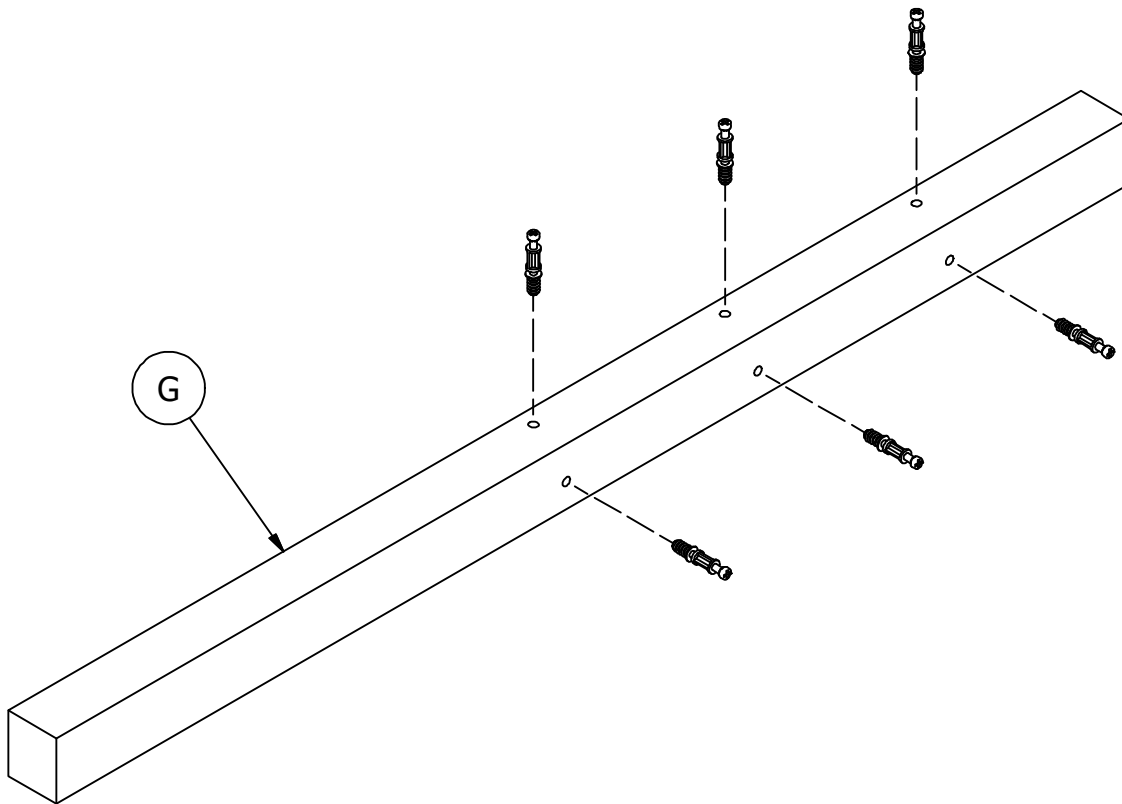
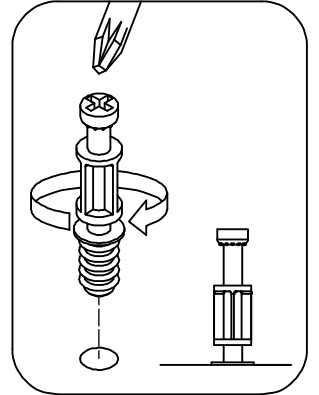

STEP 23

Assemble Panels

71659

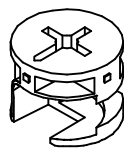

[3]

KD Cam

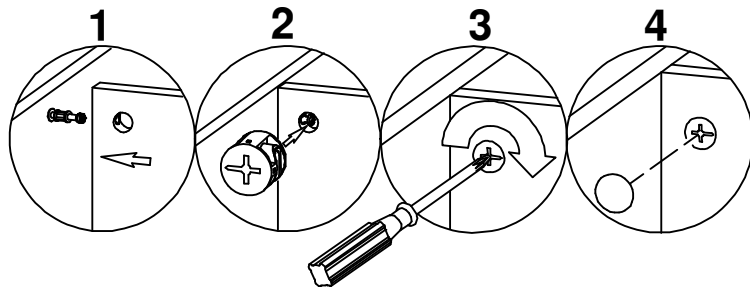

How to Tighten
KD Cams

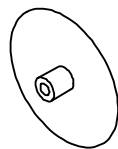

[3]

Cover Cap

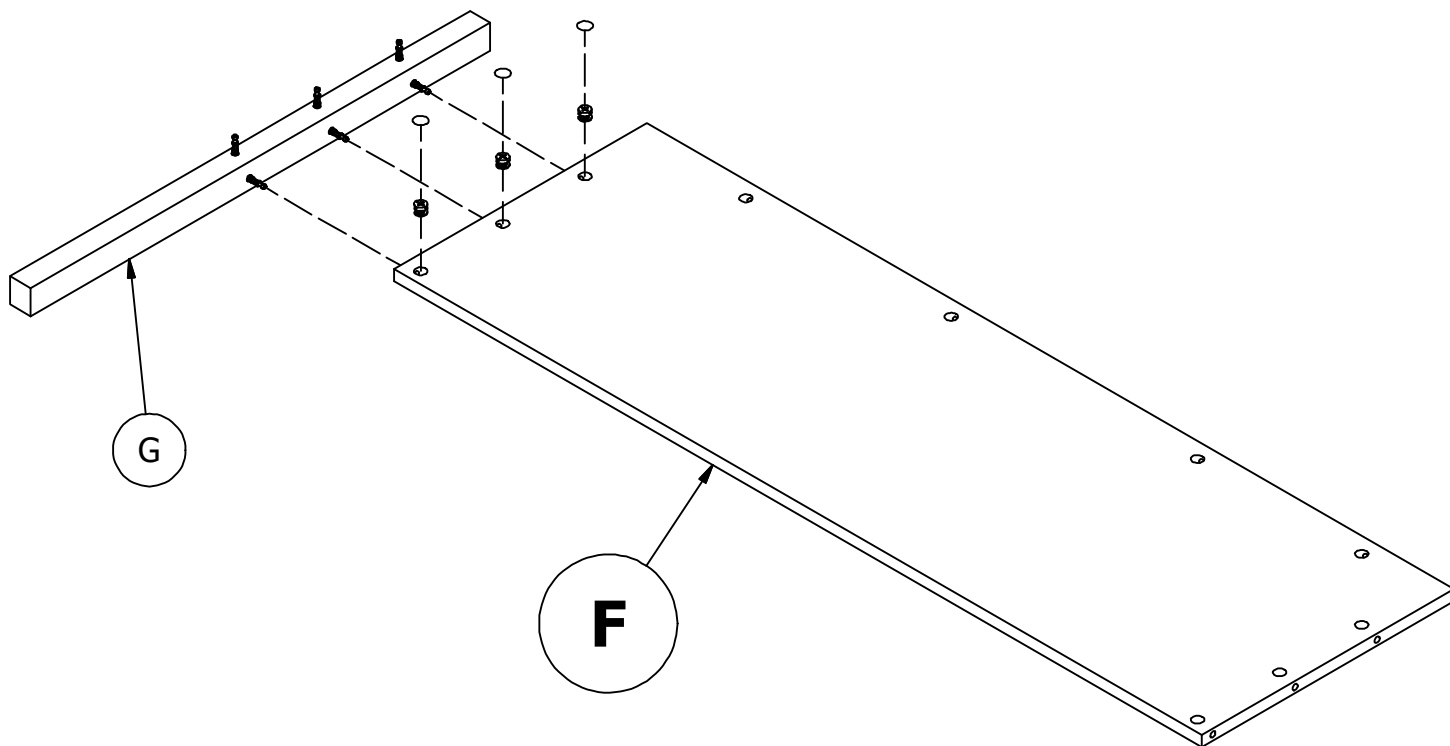

STEP 24

Assemble Panel to File Cabinet

H71659 [3]
KD Cam

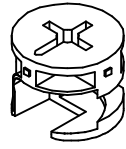

KD Cam

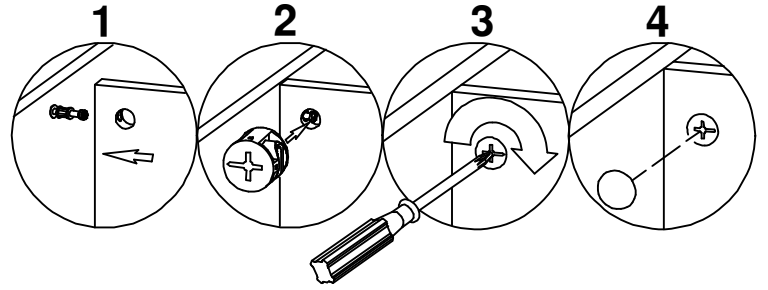

How to Tighten
KD Cams

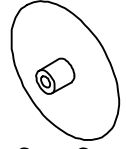

Cover Cap

[3]

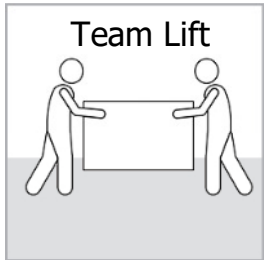

Team Lift

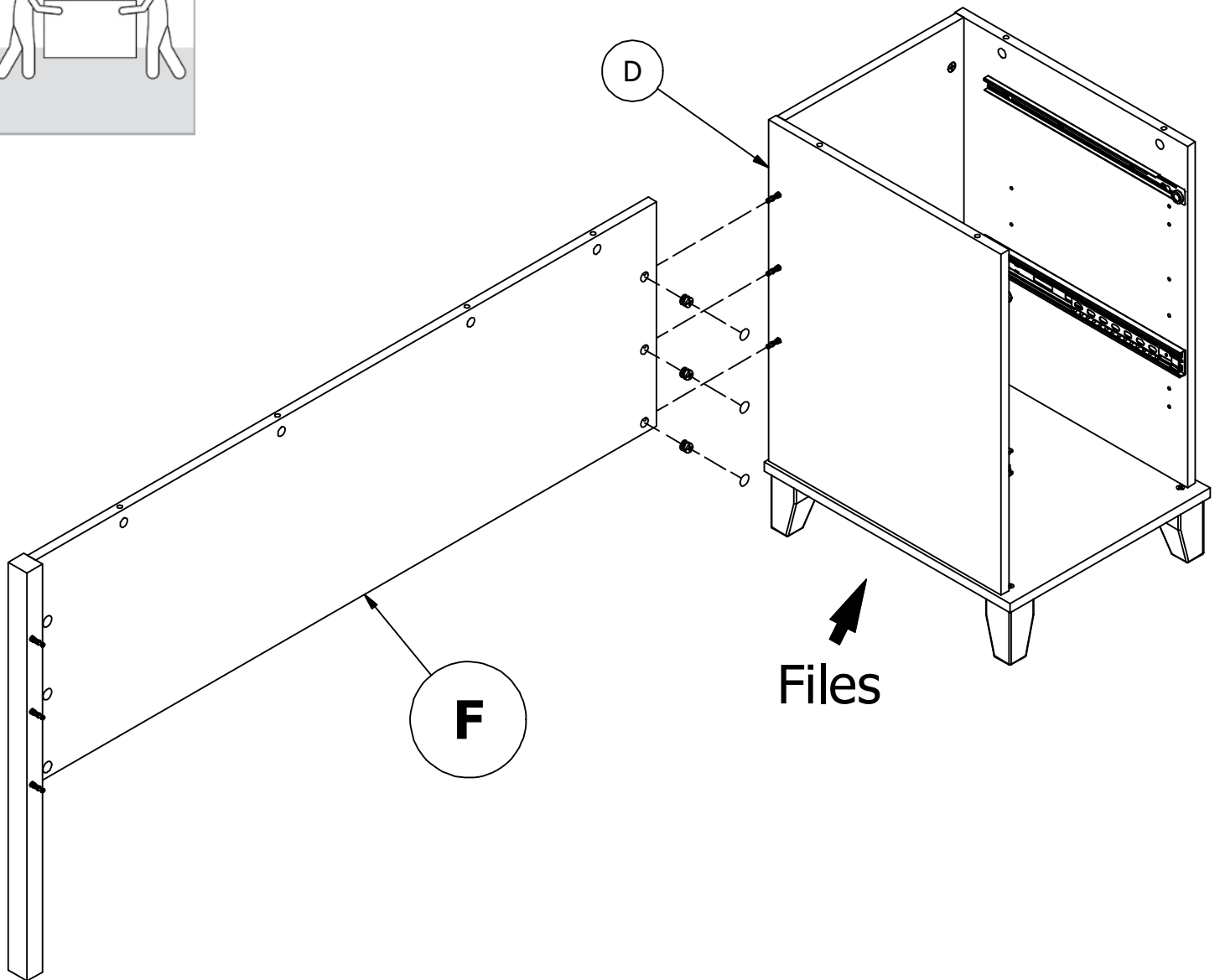

STEP 25

Assemble Panel to Storage Cabinet

H71659

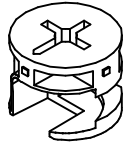

[6]

KD Cam

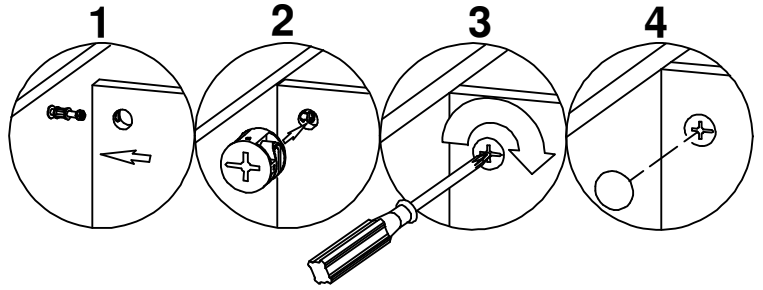

How to Tighten
KD Cams

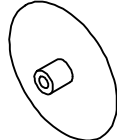

[6]

Cover Cap

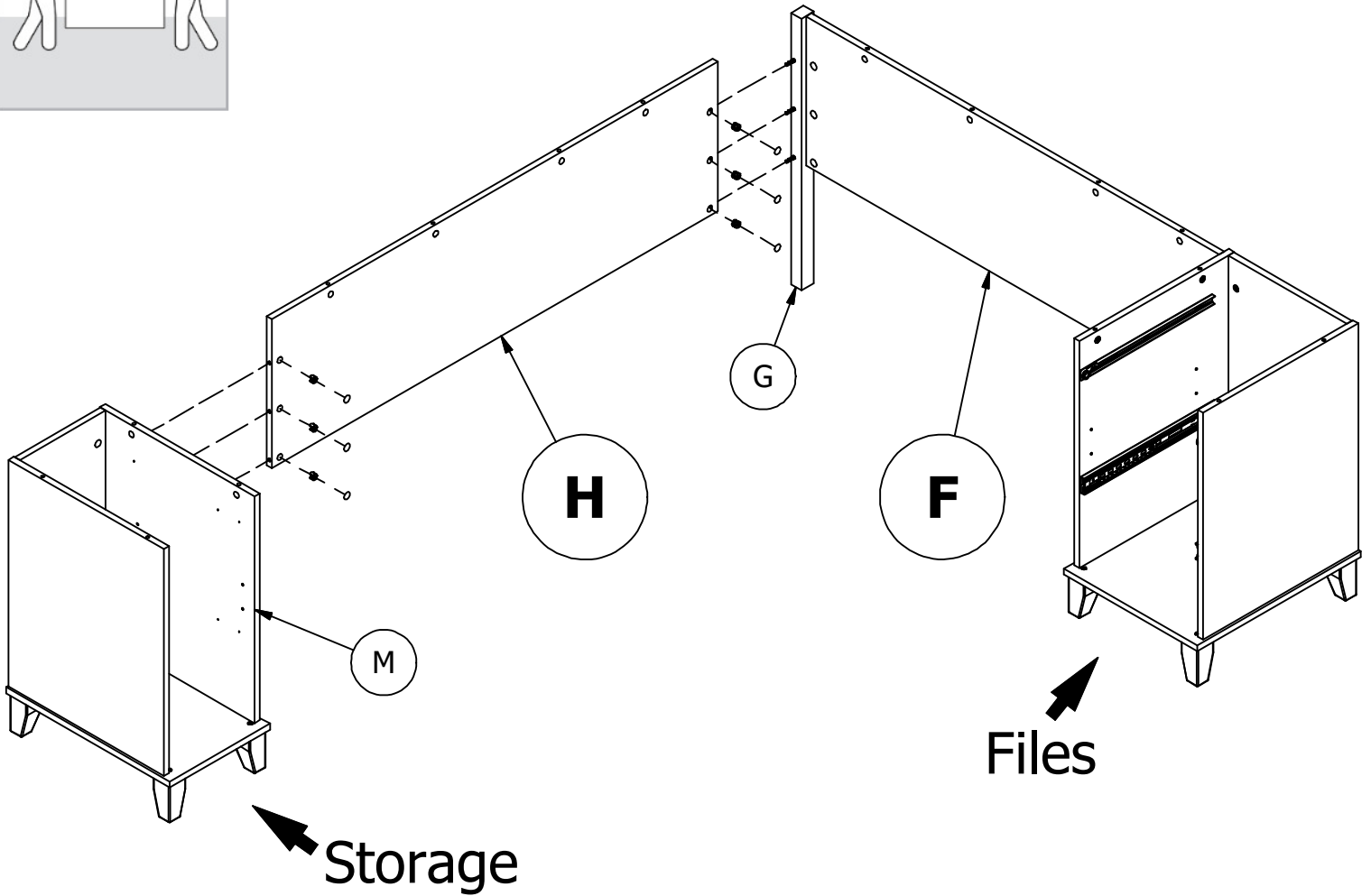
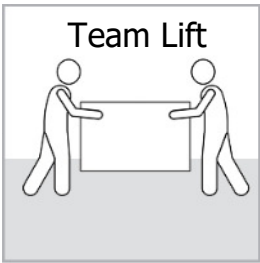

STEP 26

Prepare Panel

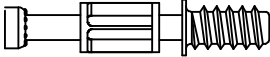
H72988  [9]
KD Bolt

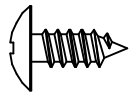
H35251  [4]
#10 x 1/2"

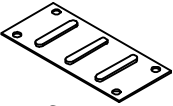
H39922  [2]
Strap

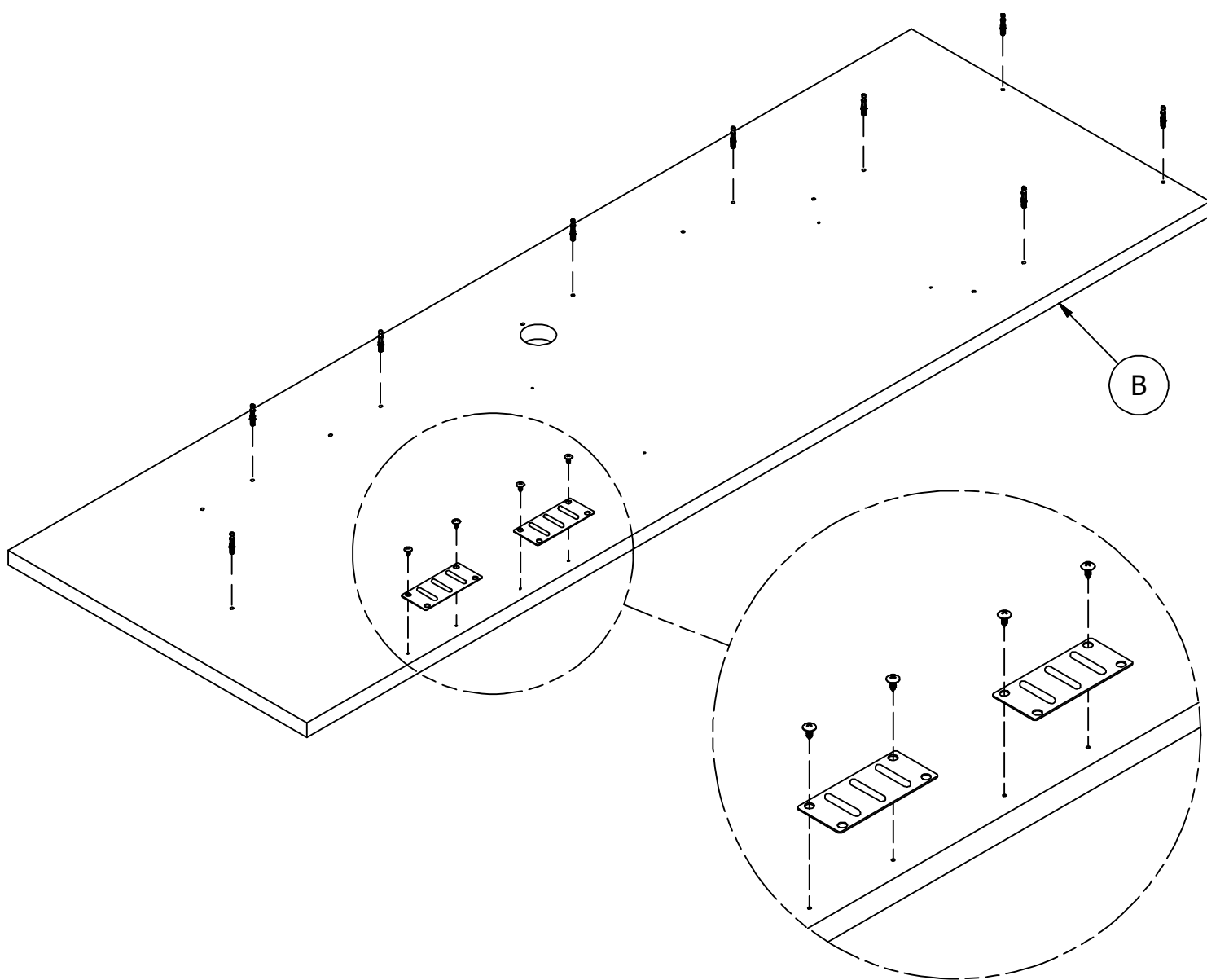
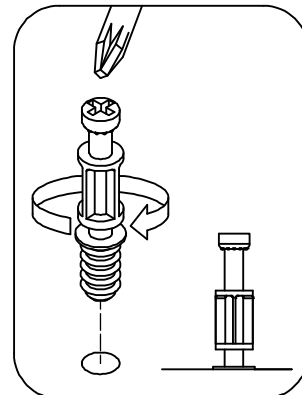

STEP 27

Attach Keyboard Hardware

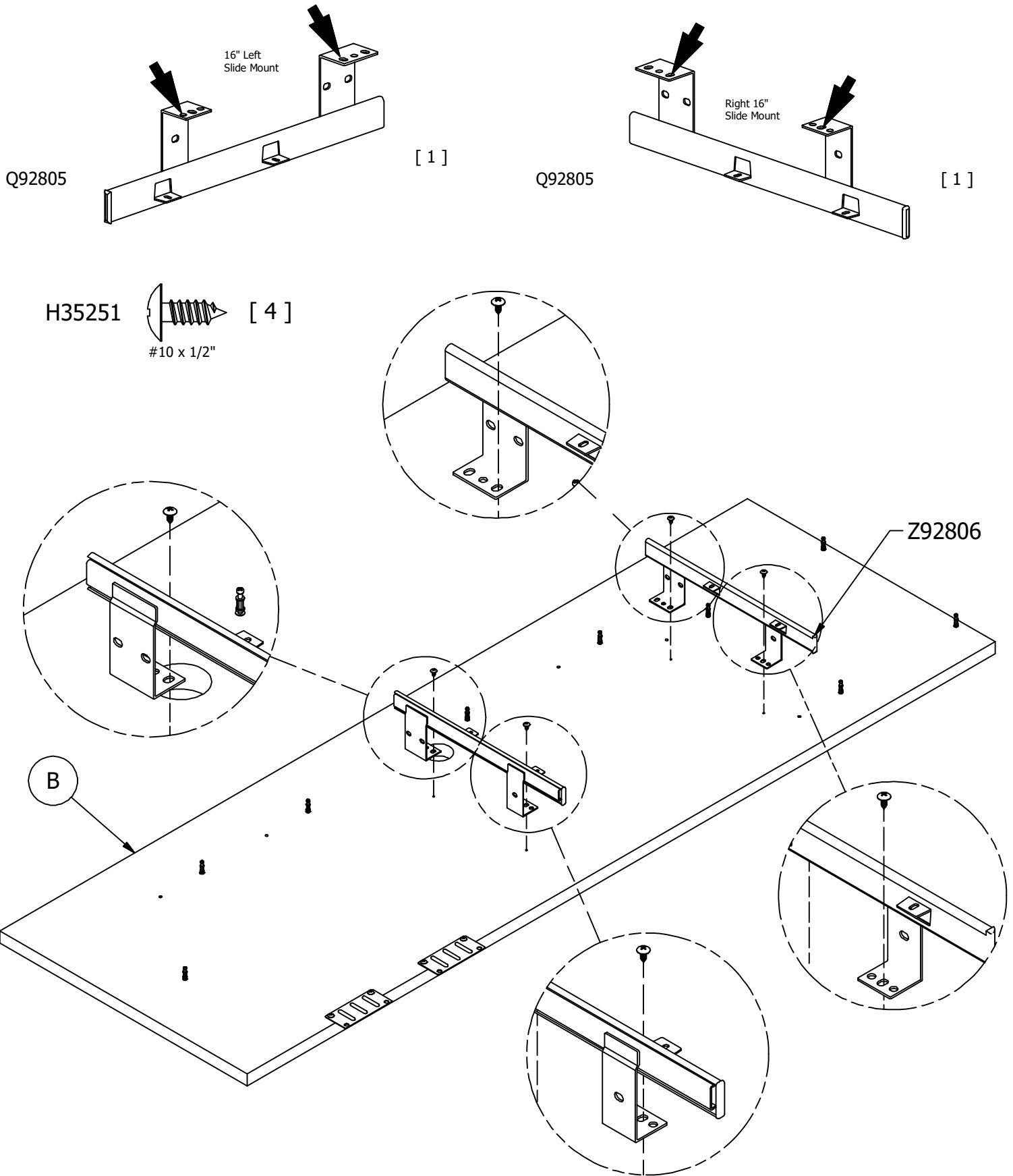

STEP 28

Assemble Panels

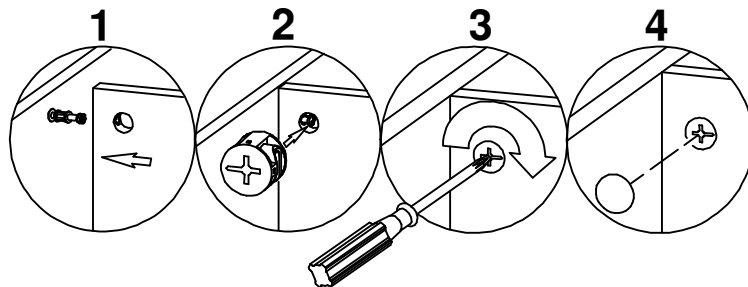
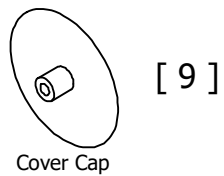
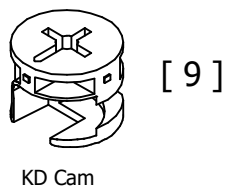

How to Tighten
KD Cams

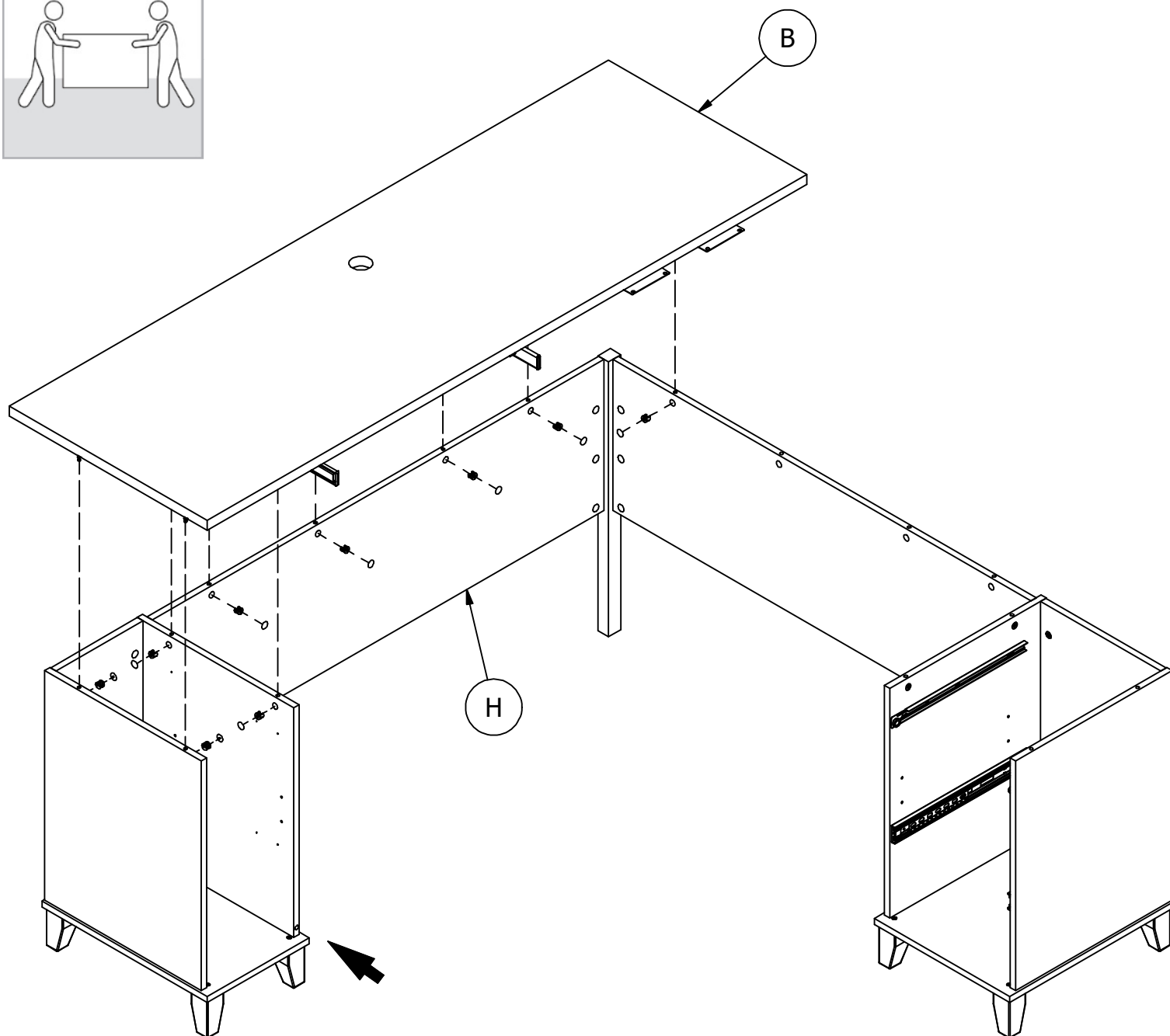
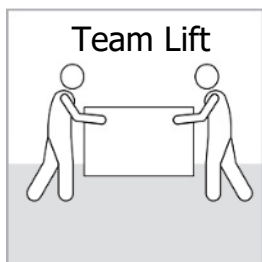

STEP 29

Prepare Panel

H72988 [7]
KD Bolt

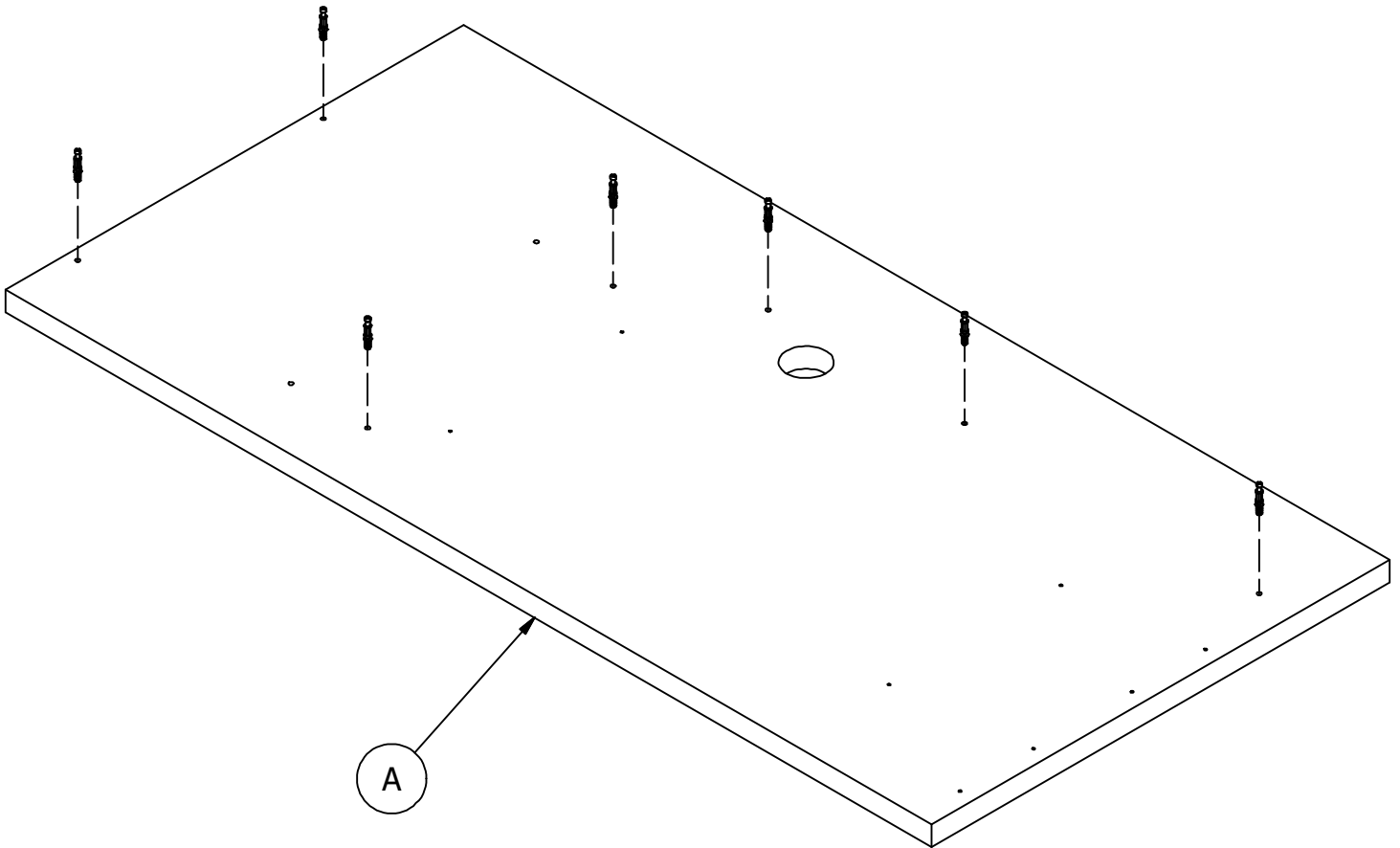
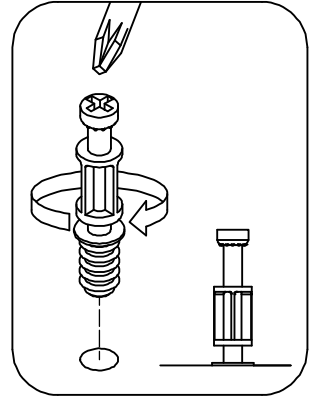

STEP 30

Assemble Panels

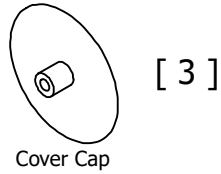
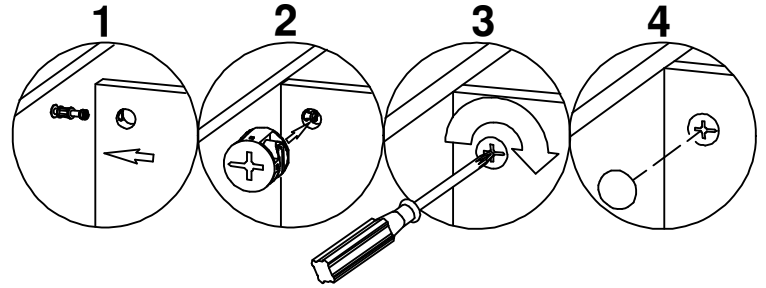
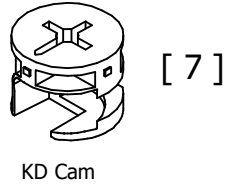

How to Tighten
KD Cams

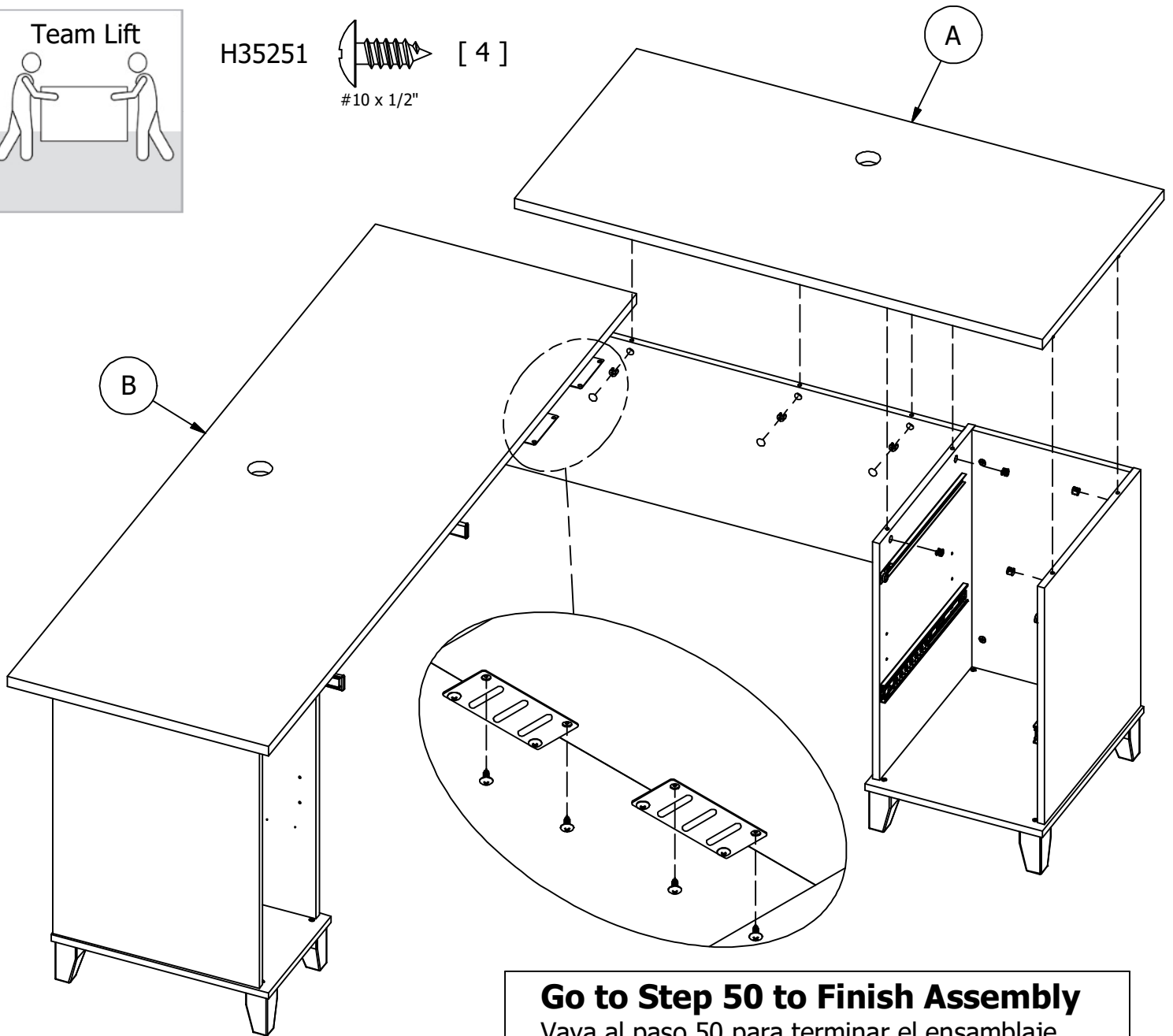
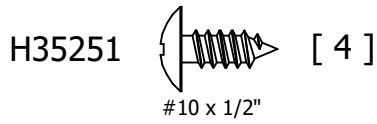
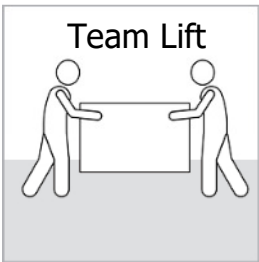

Go to Step 50 to Finish Assembly
Vaya al paso 50 para terminar el ensamblaje
Passez à l'étape 50 pour terminer l'assemblage

STEP 31

Prepare Panels

Begin Option 2 Assembly
Comenzar el ensamblaje de la opción 2
Commencer l'assemblage de l'option 2

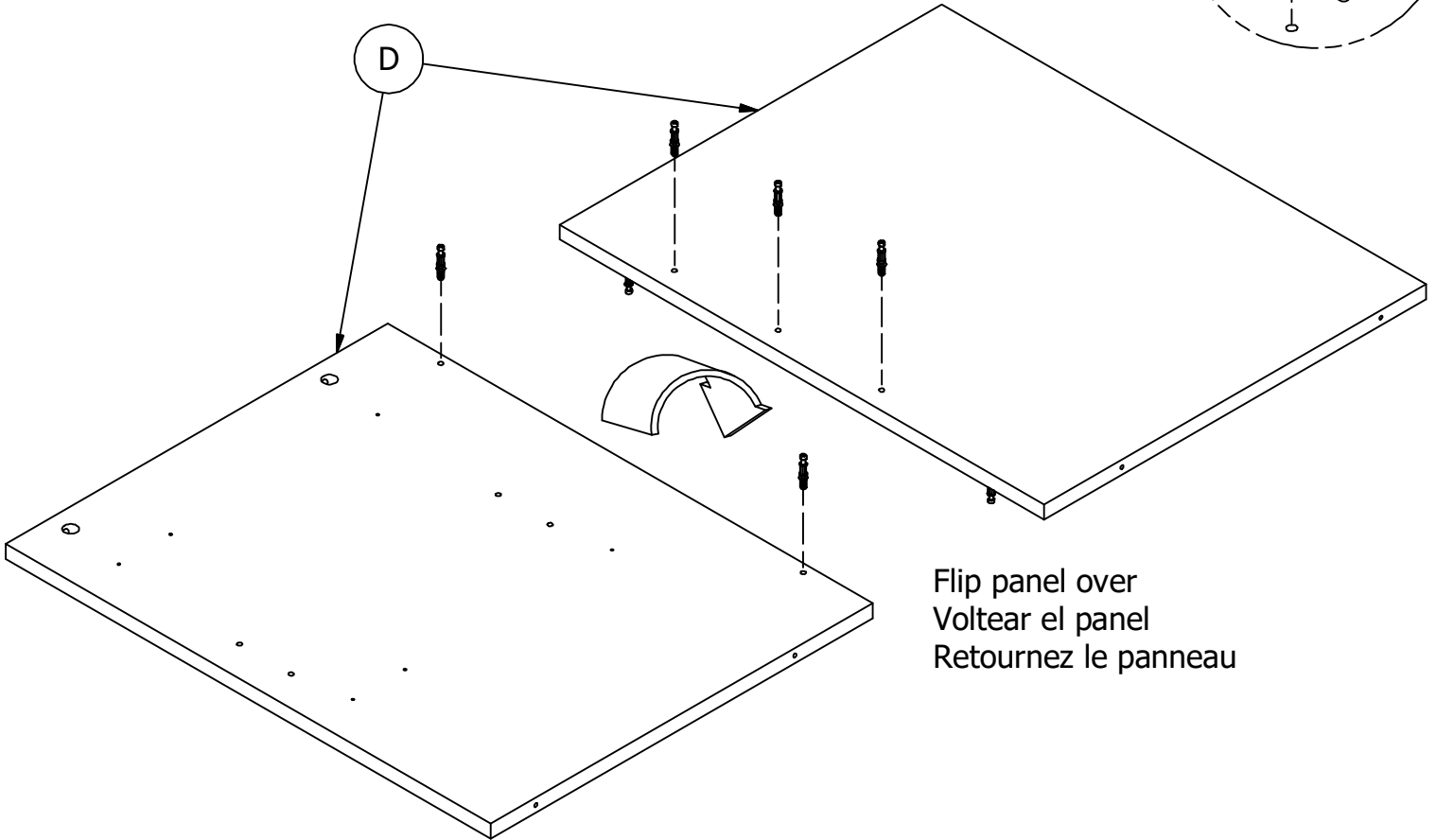
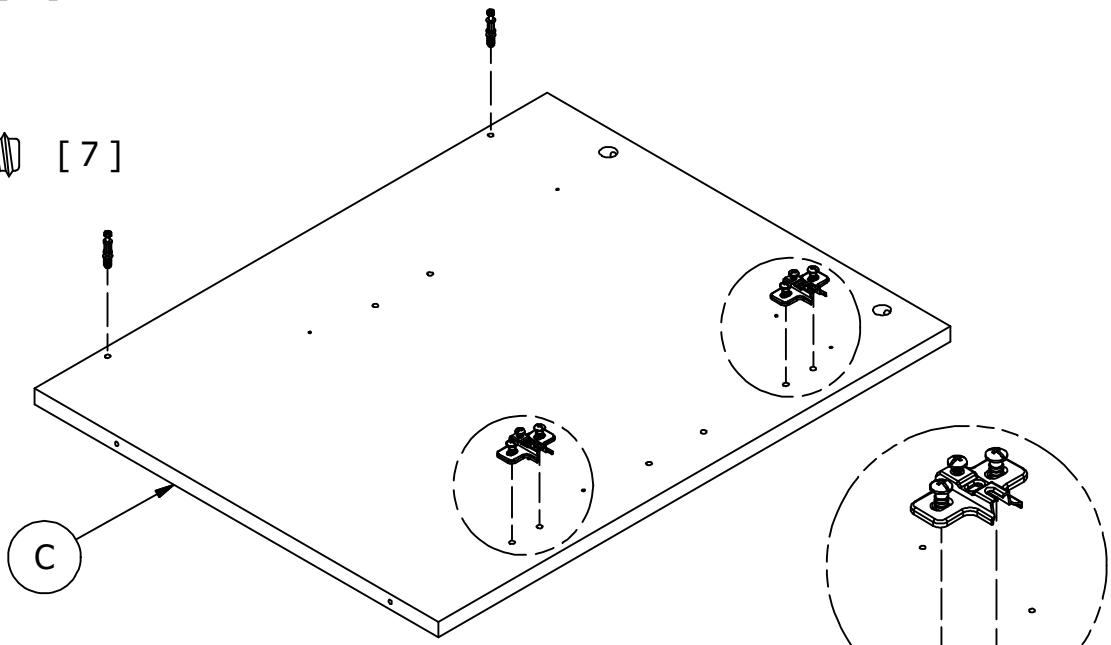
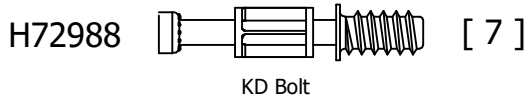
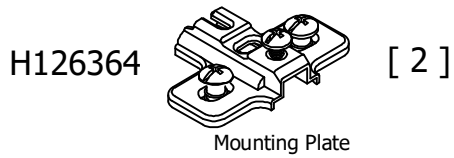

Flip panel over
Voltrear el panel
Retournez le panneau

STEP 31

Assemble Panels

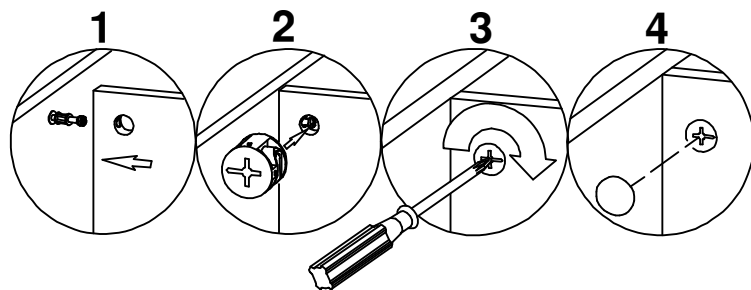
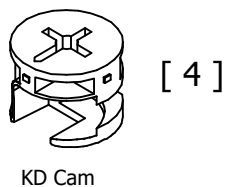

How to Tighten
KD Cams

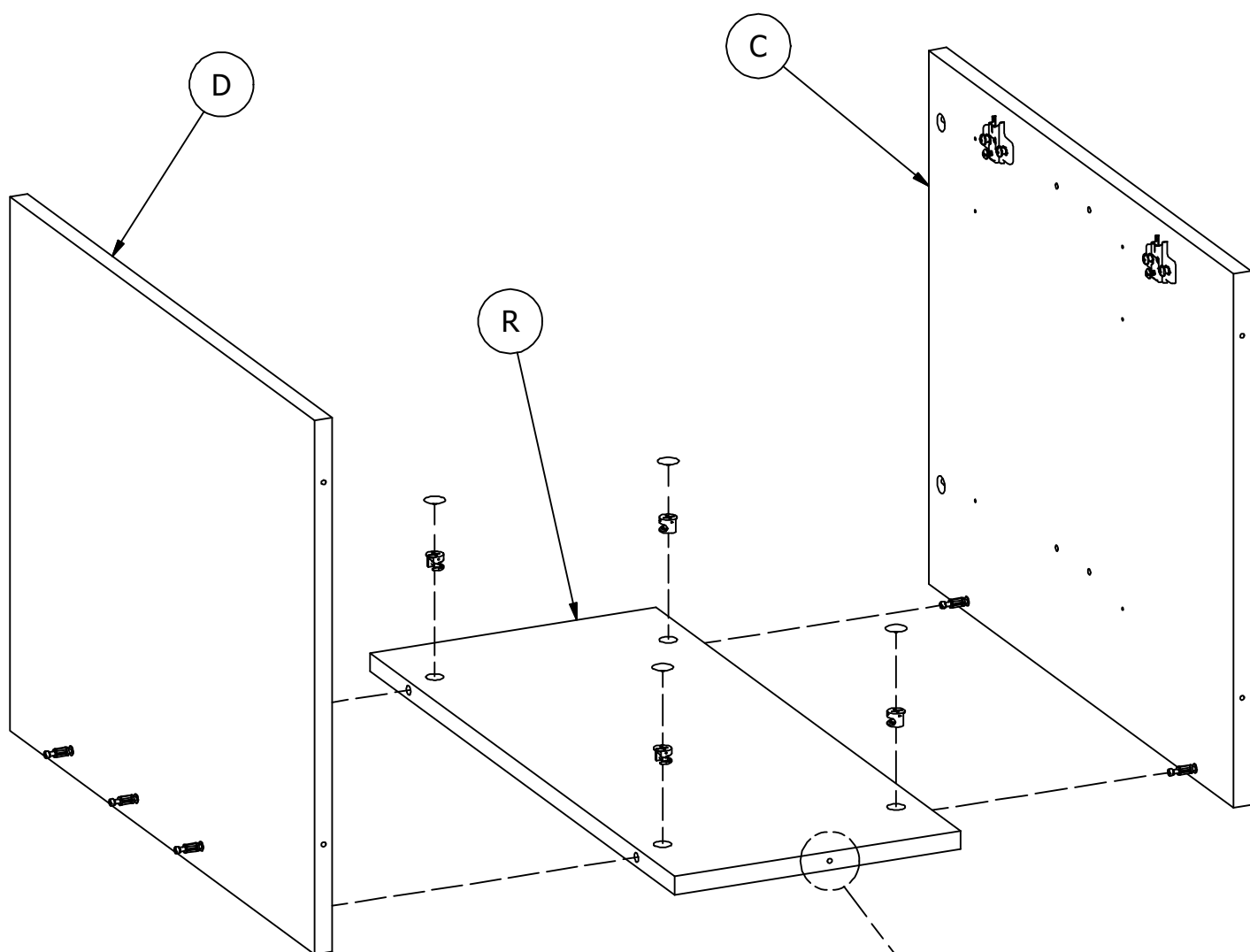
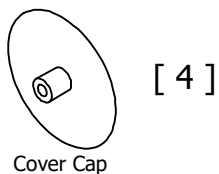

Orientation
Orientación
L'orientation

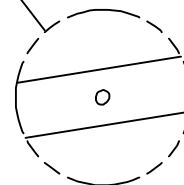

STEP 33

Assemble Panels

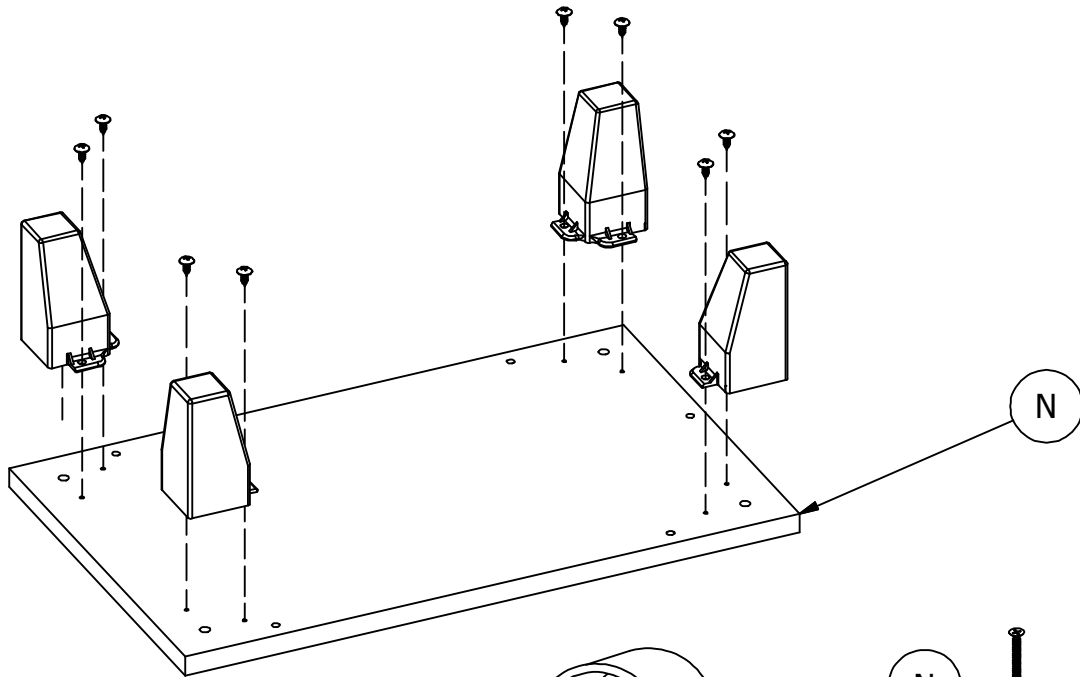
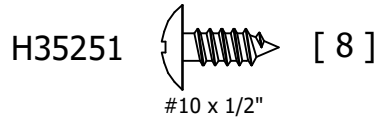
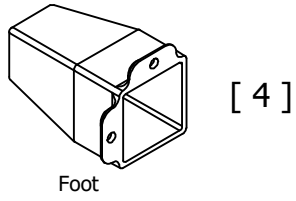
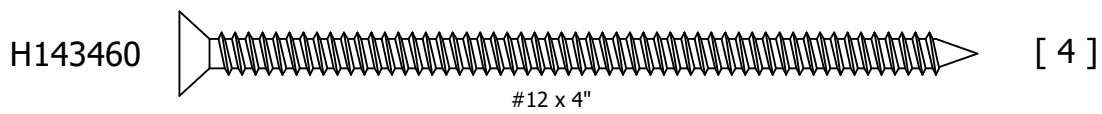

Flip panel over
Voltear el panel
Retournez le panneau

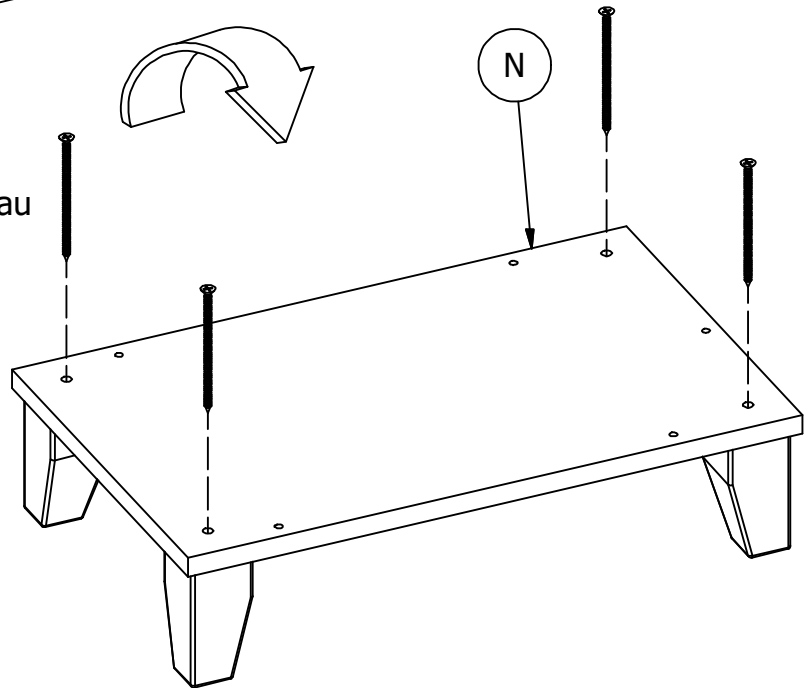

STEP 34

Assemble Panels

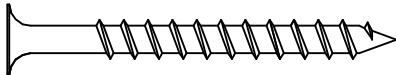
H23491  [5]
#10 x 2"

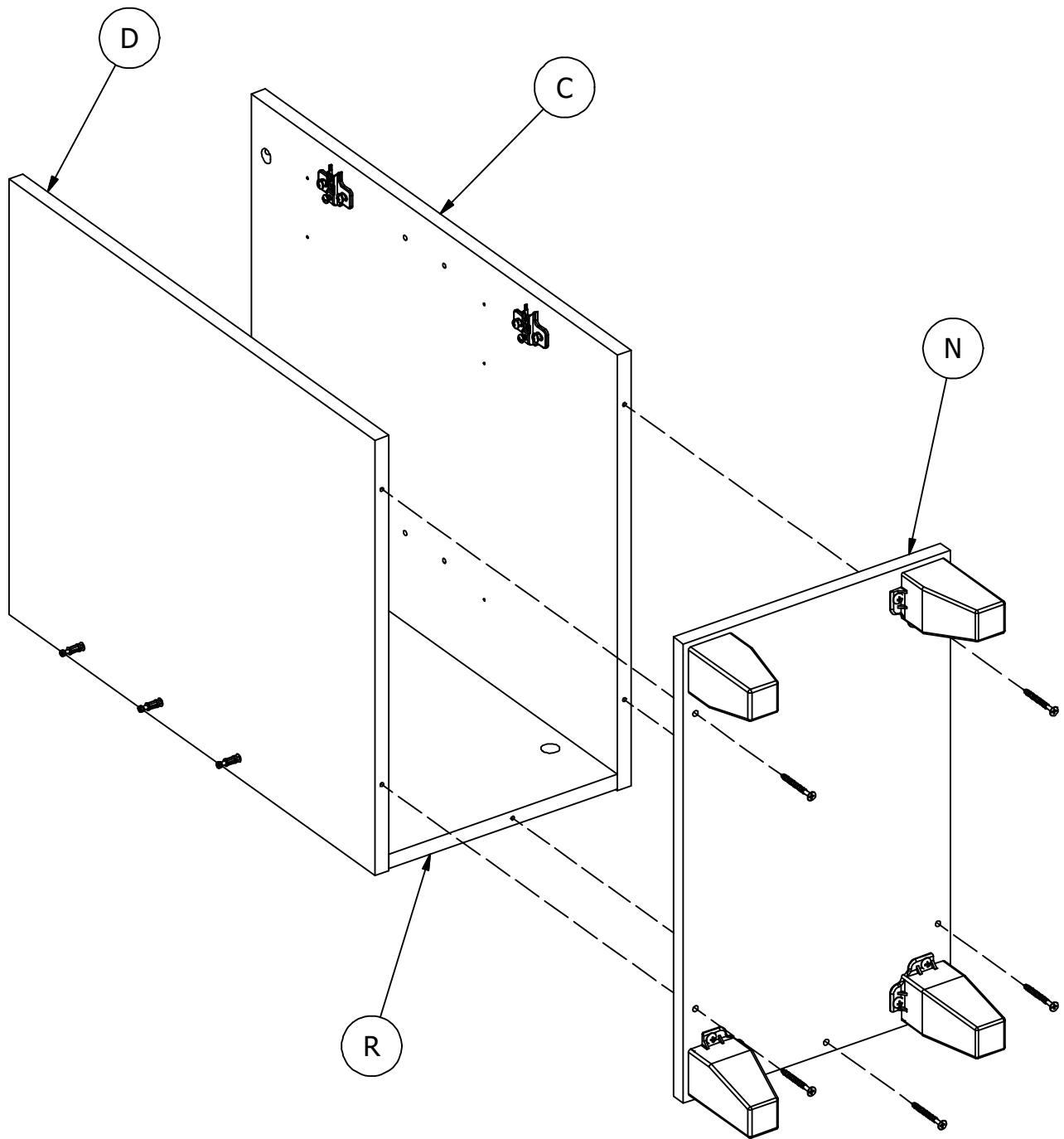

STEP 35

Prepare Panel

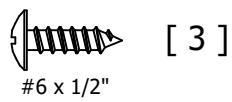
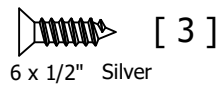

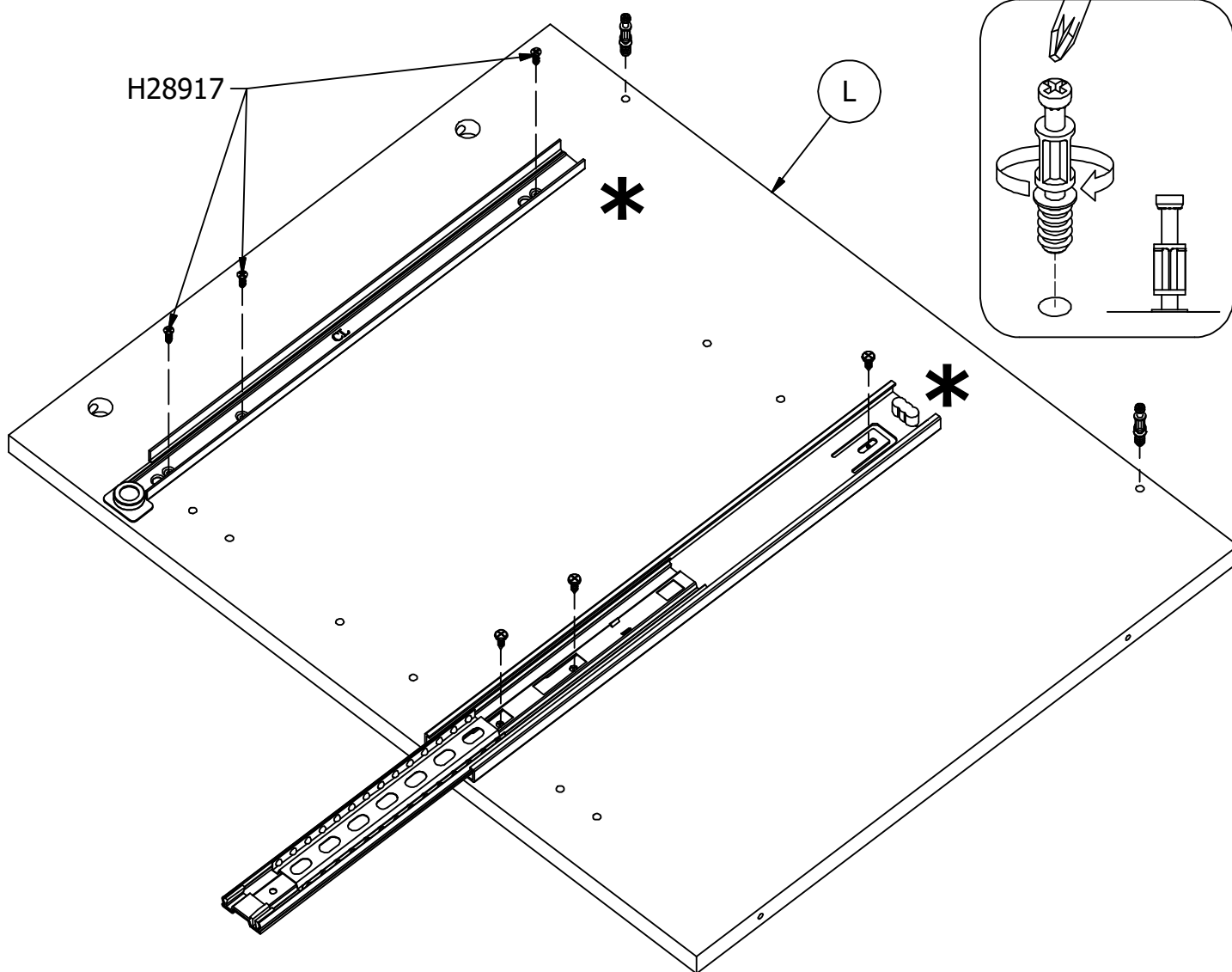
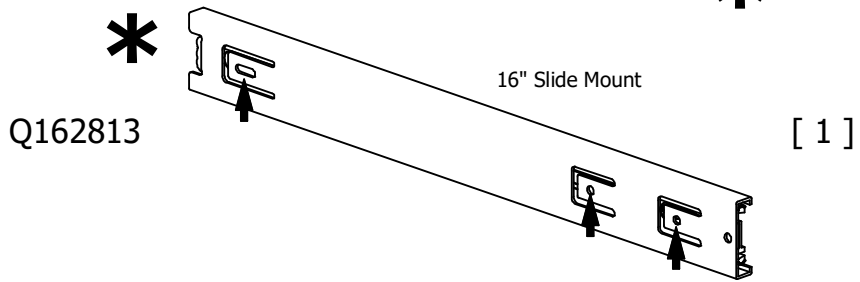
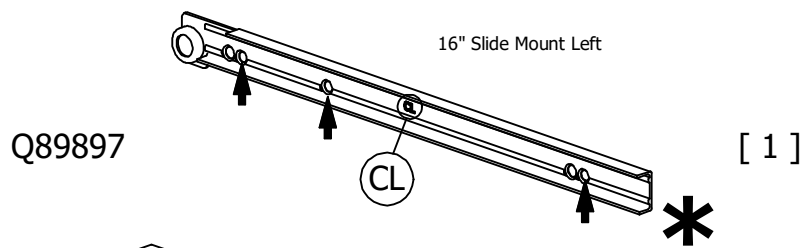
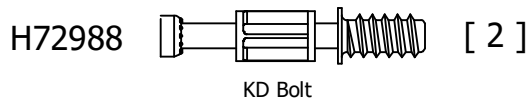

and Install Drawer Slides

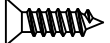

STEP 36

Prepare Panel

28917  [3]
#6 x 1/2" Silver

101725  [3]
#6 x 1/2"

How to Separate
and Install Drawer
Slides

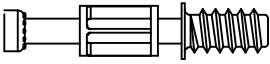
H72988  [2]
KD Bolt

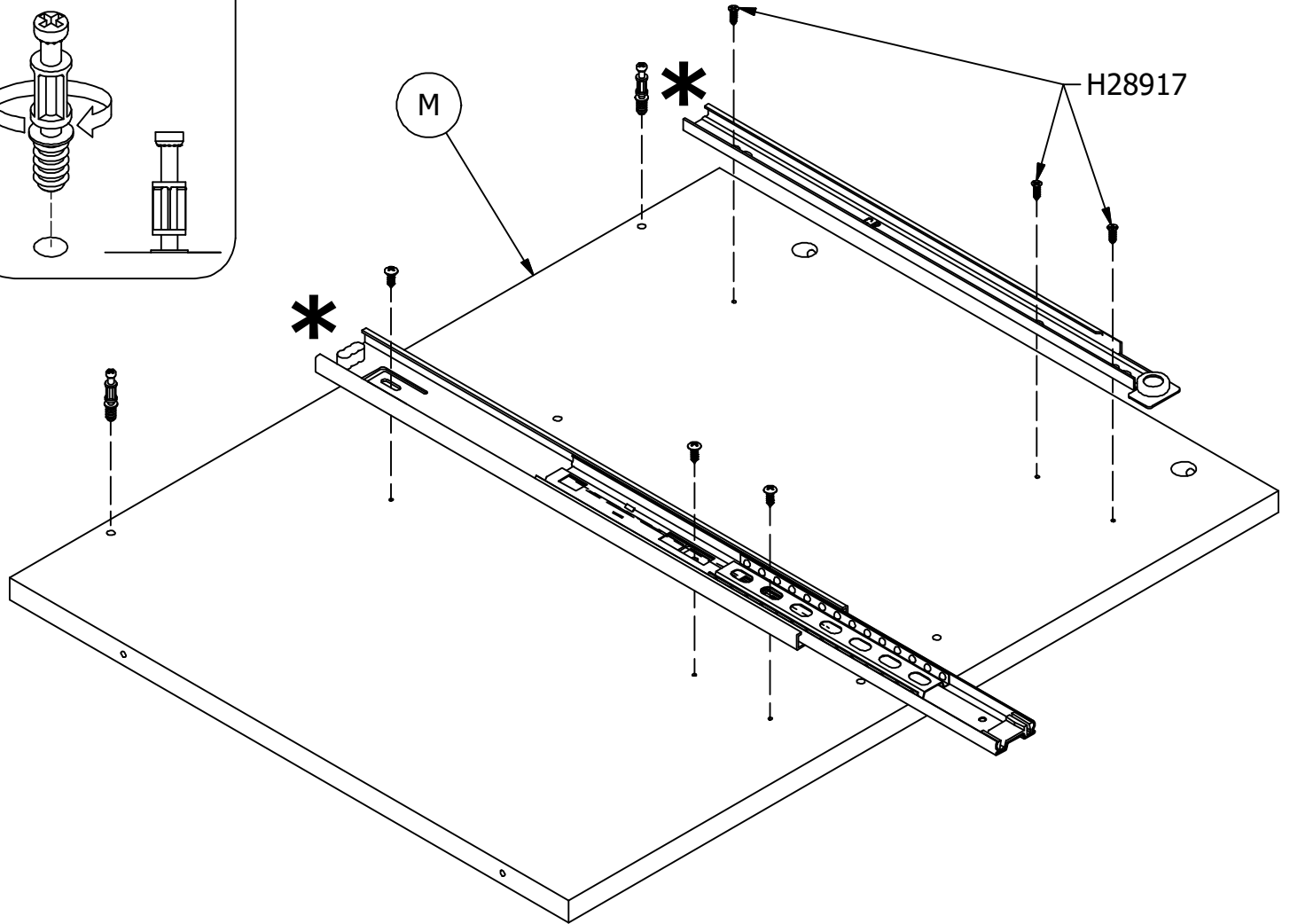
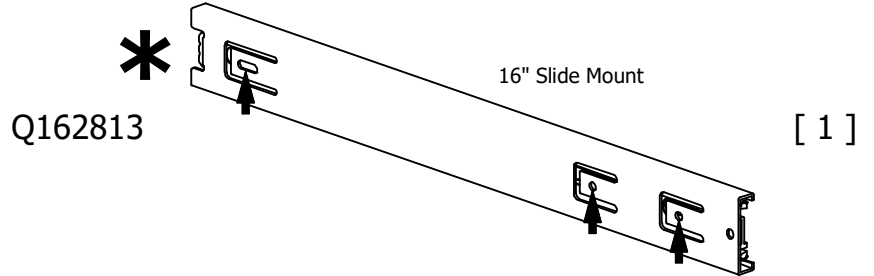
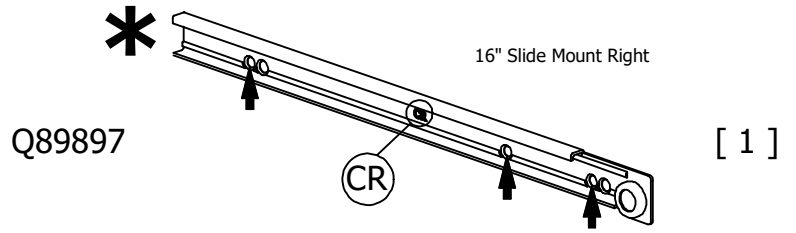
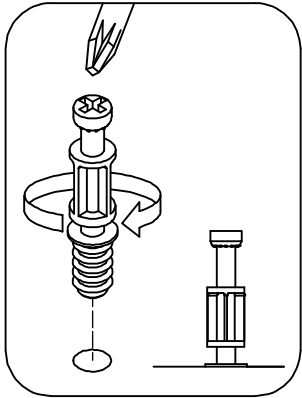

STEP 37

Prepare Panel

H72988 [3]
KD Bolt

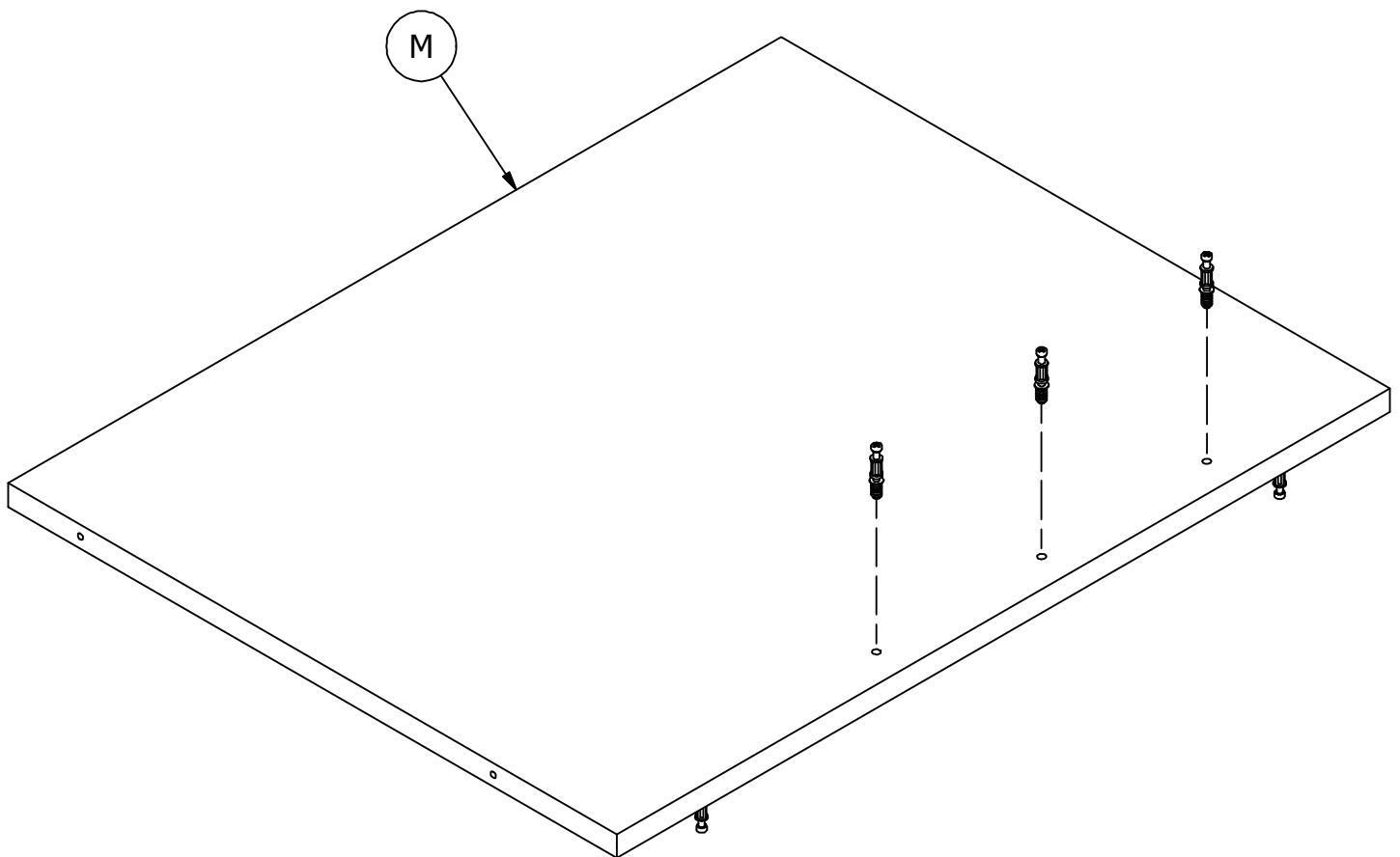
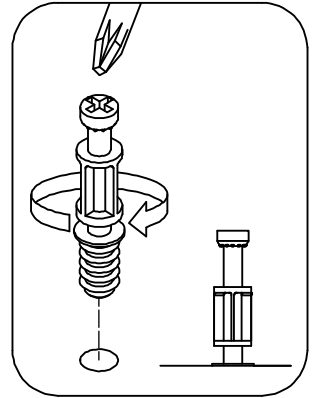

STEP 38

Assemble Panels

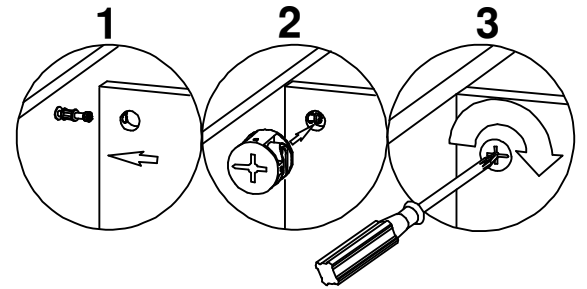
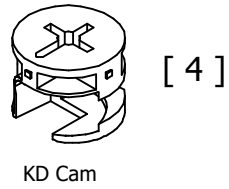

How to Tighten
KD Cams

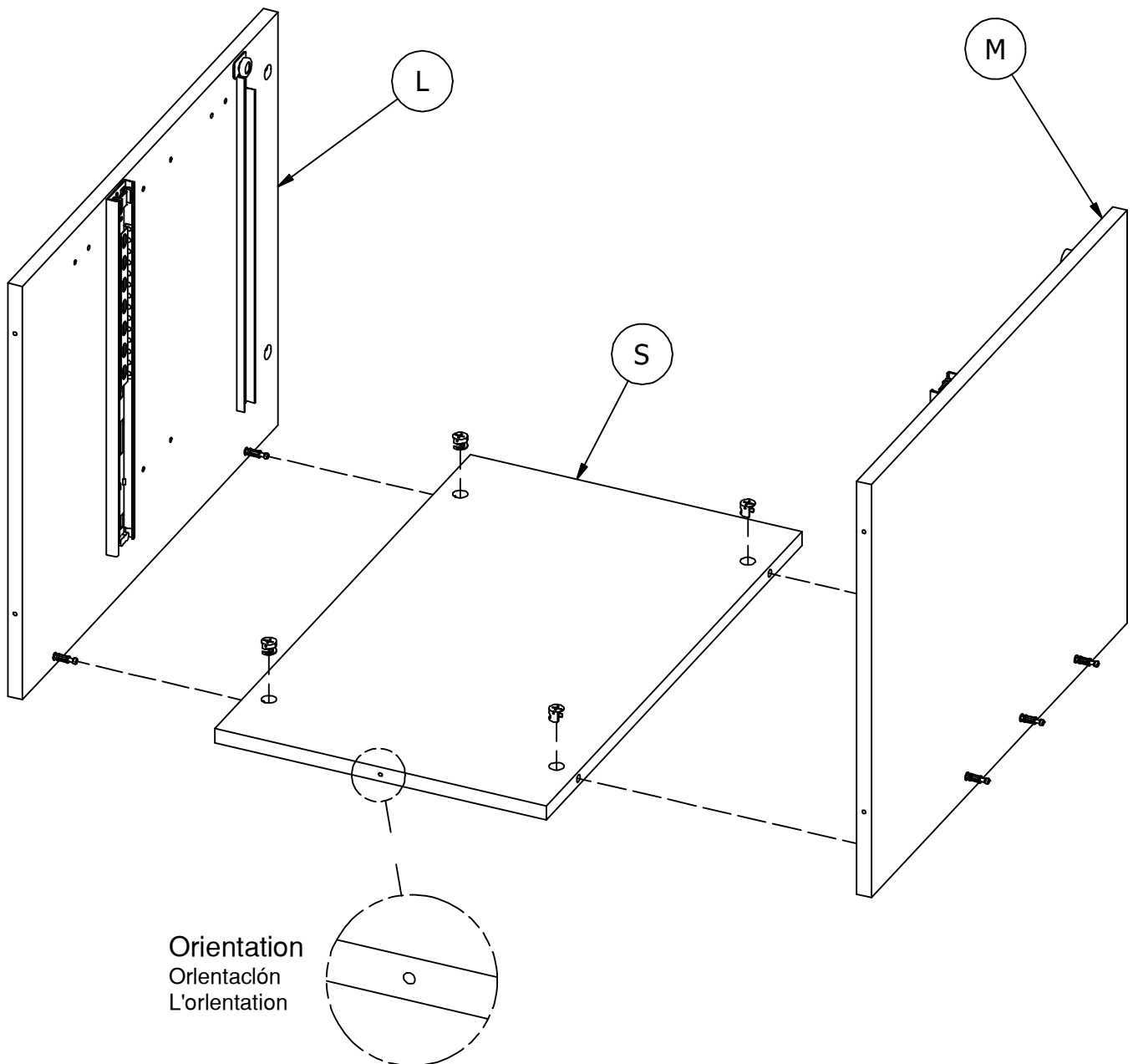

STEP 39

Prepare Panel

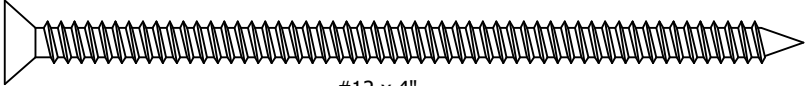
H143460  [4]
#12 x 4"

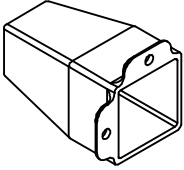
 [4]
Foot

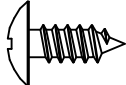
H35251  [8]
#10 x 1/2"

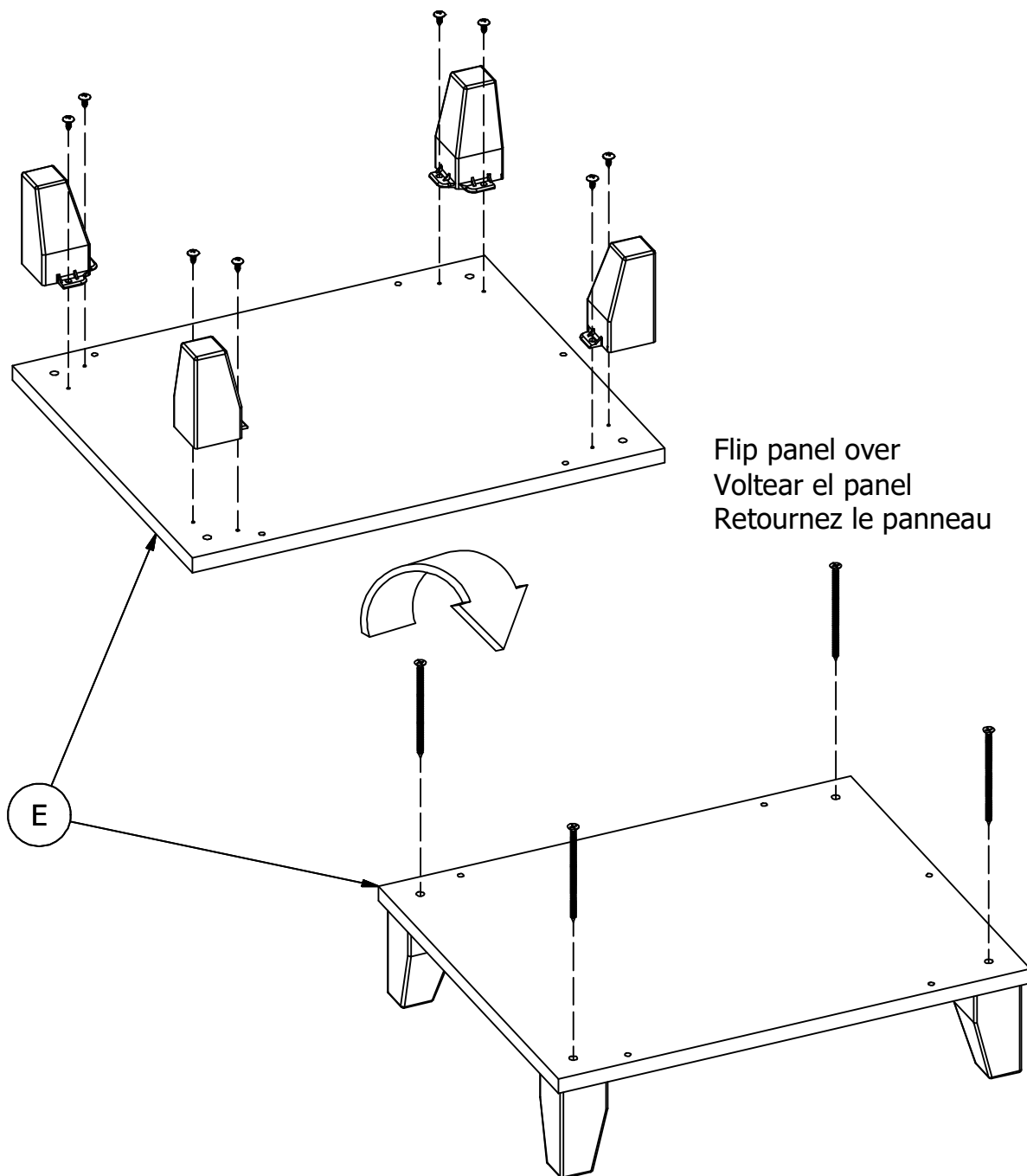

Flip panel over
Voltear el panel
Retournez le panneau

STEP 40

Assemble Panels

H23491

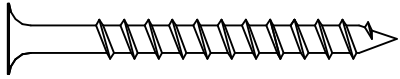

[5]

#10 x 2"

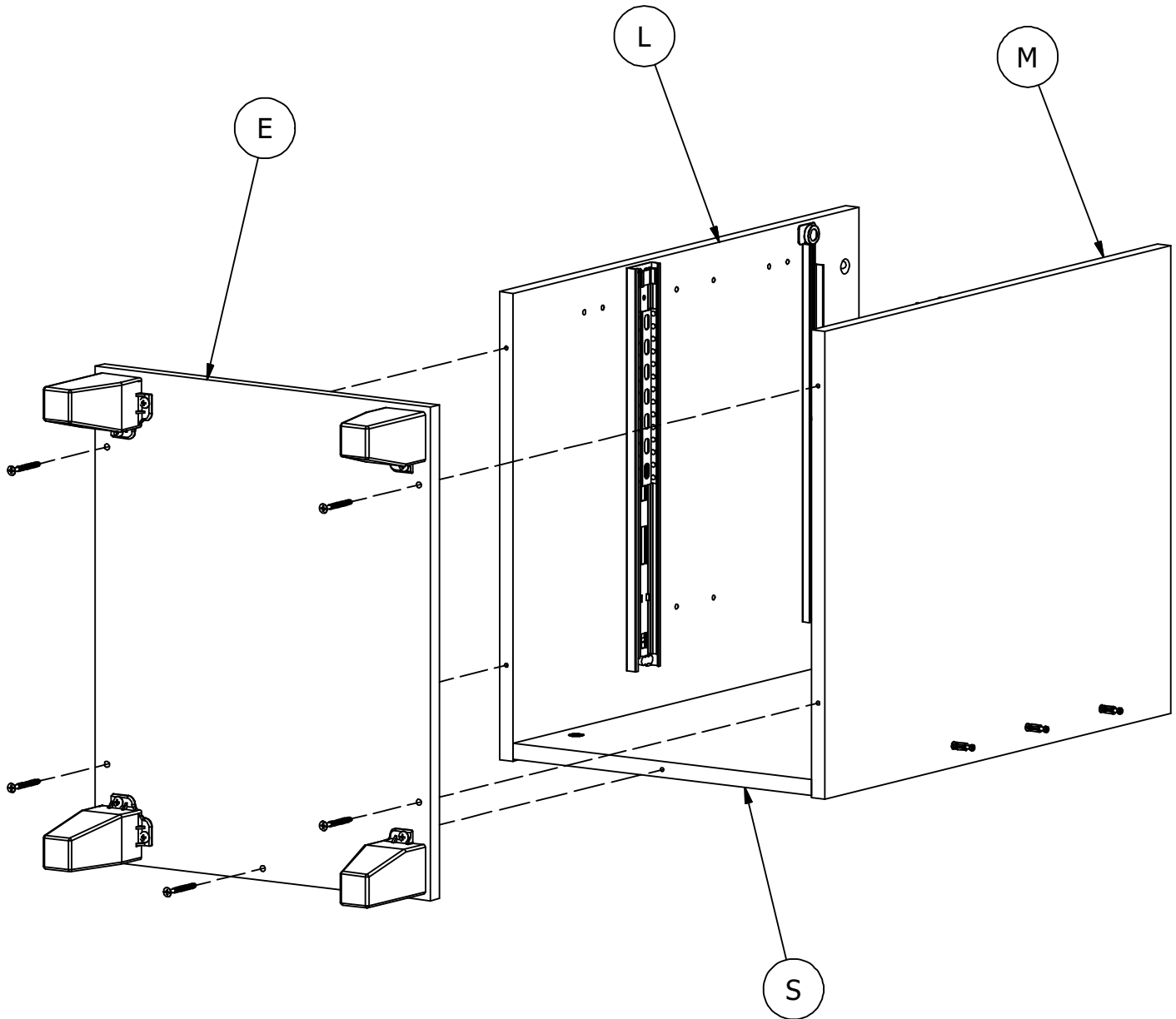

STEP 41

Prepare Rear Leg

H72988 [6]
KD Bolt

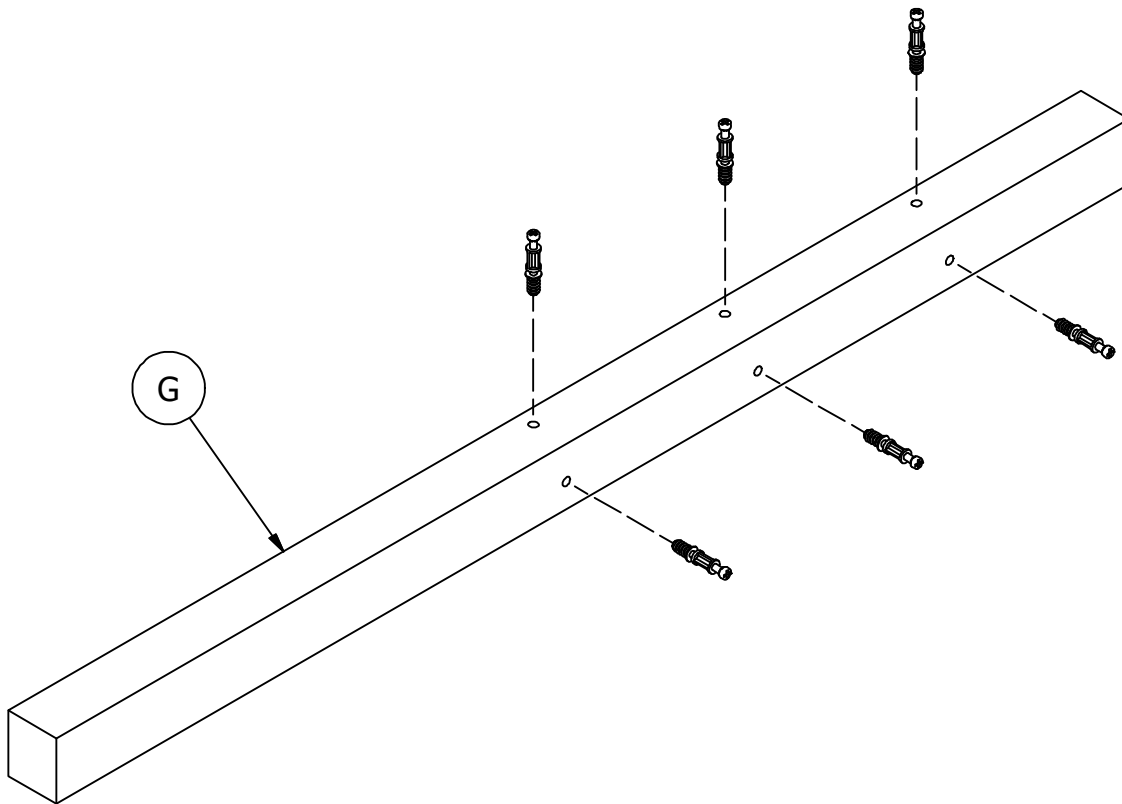
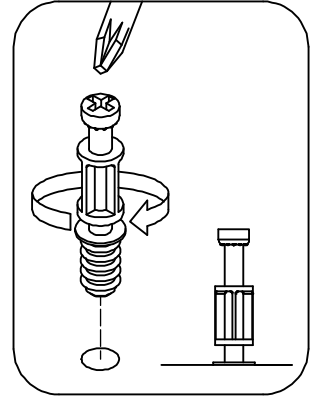

STEP 42

Assemble Panels

H71659

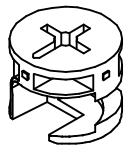

[3]

KD Cam

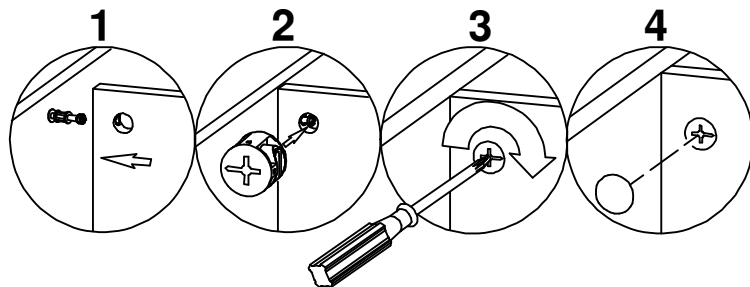

How to Tighten
KD Cams



[3]

Cover Cap

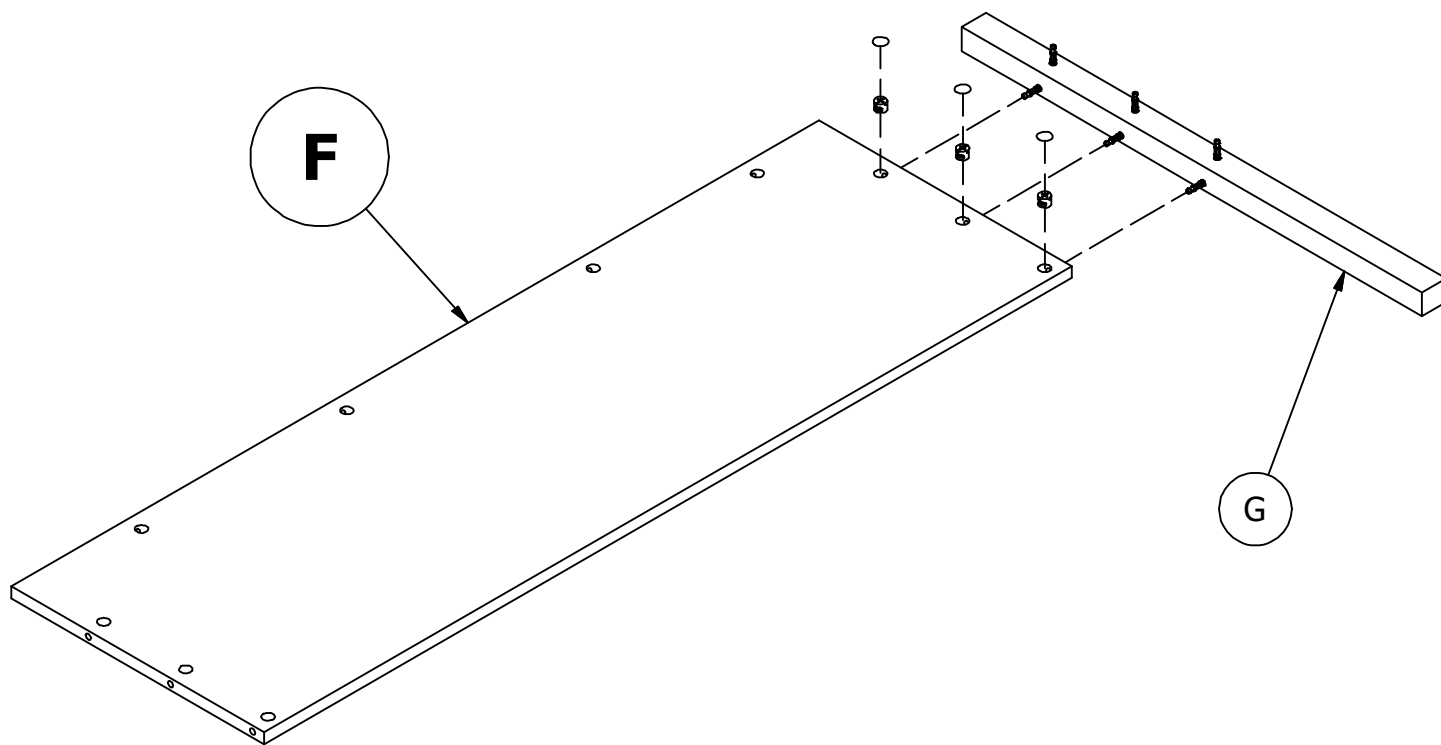

STEP 43

Assemble Panel to File Cabinet

- H71659 [3]
KD Cam
- [3]
Cover Cap

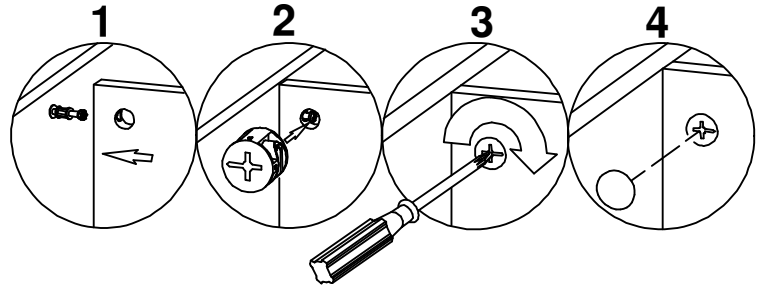

How to Tighten
KD Cams

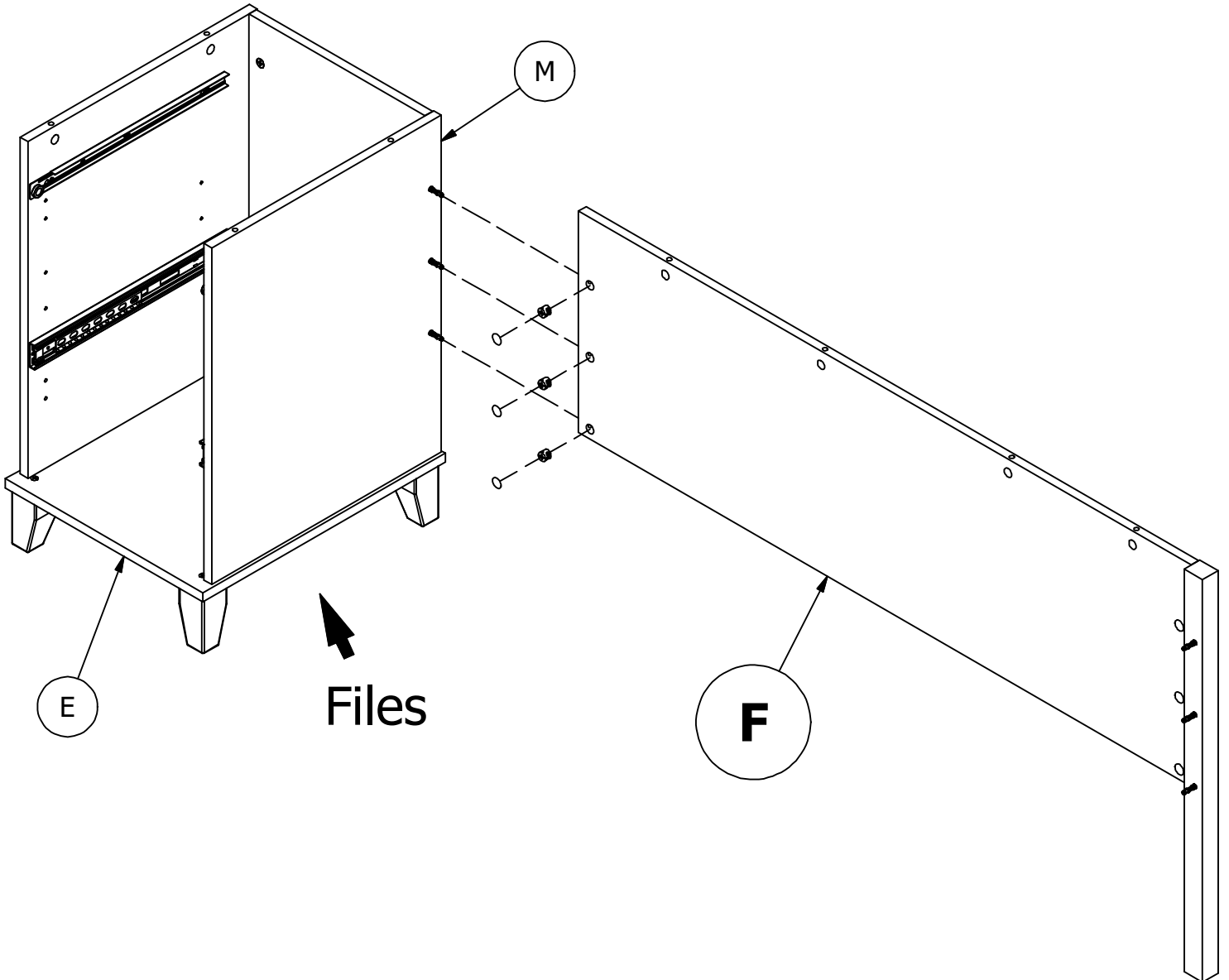
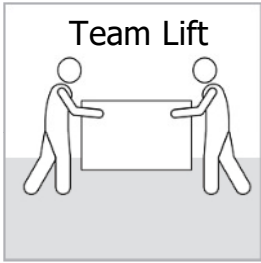

STEP 44

Assemble Panel to Storage Cabinet

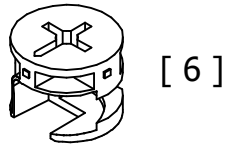

KD Cam

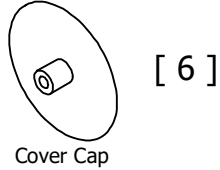

Cover Cap

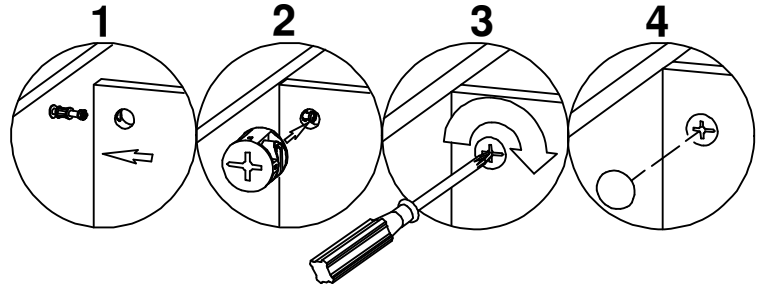

How to Tighten
KD Cams

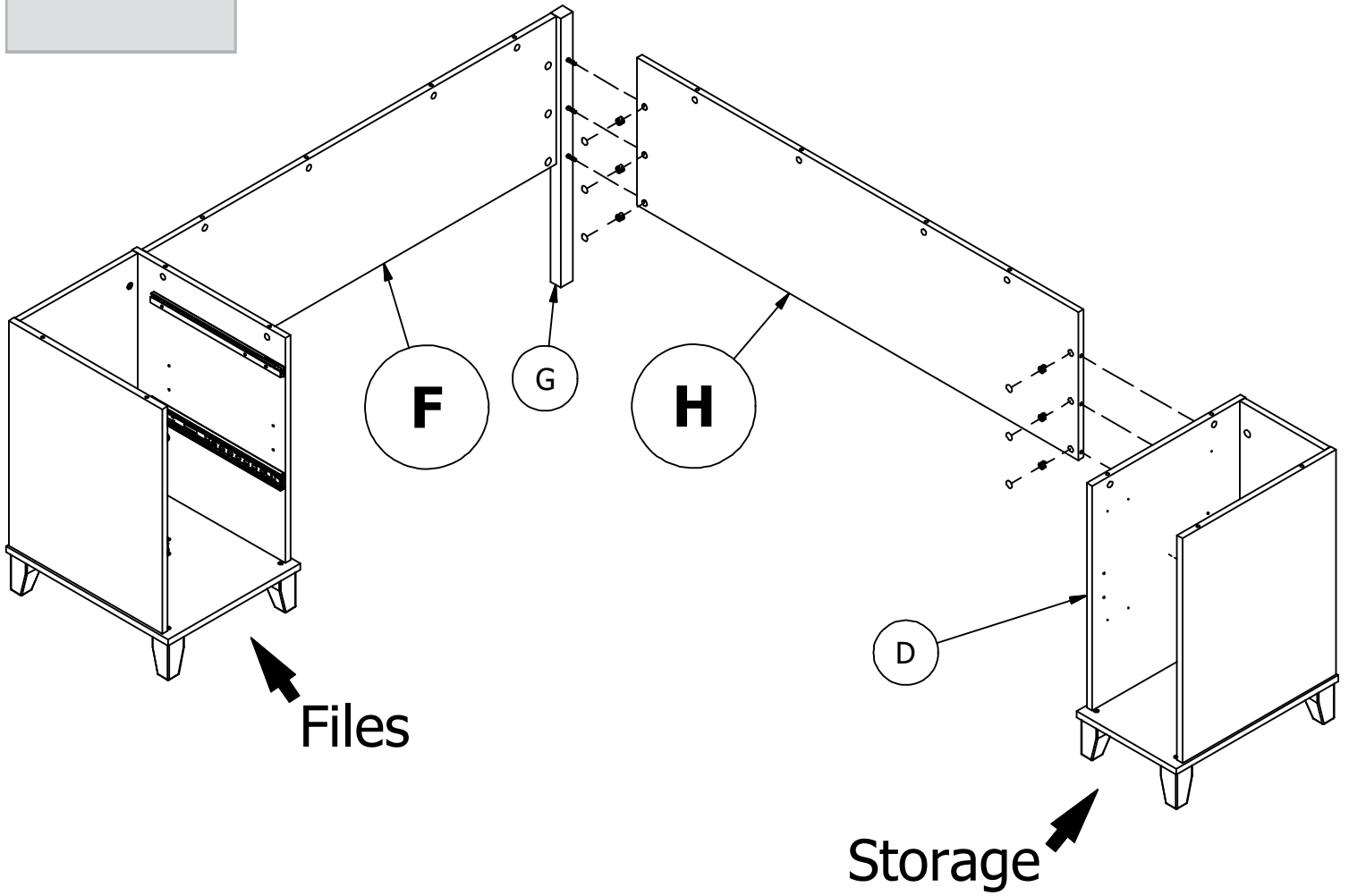
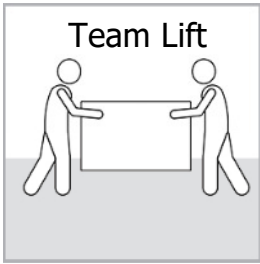

STEP 45

Prepare Panel

H72988 [9]
KD Bolt

H35251 [4]
#10 x 1/2"

H39922 [2]
Strap

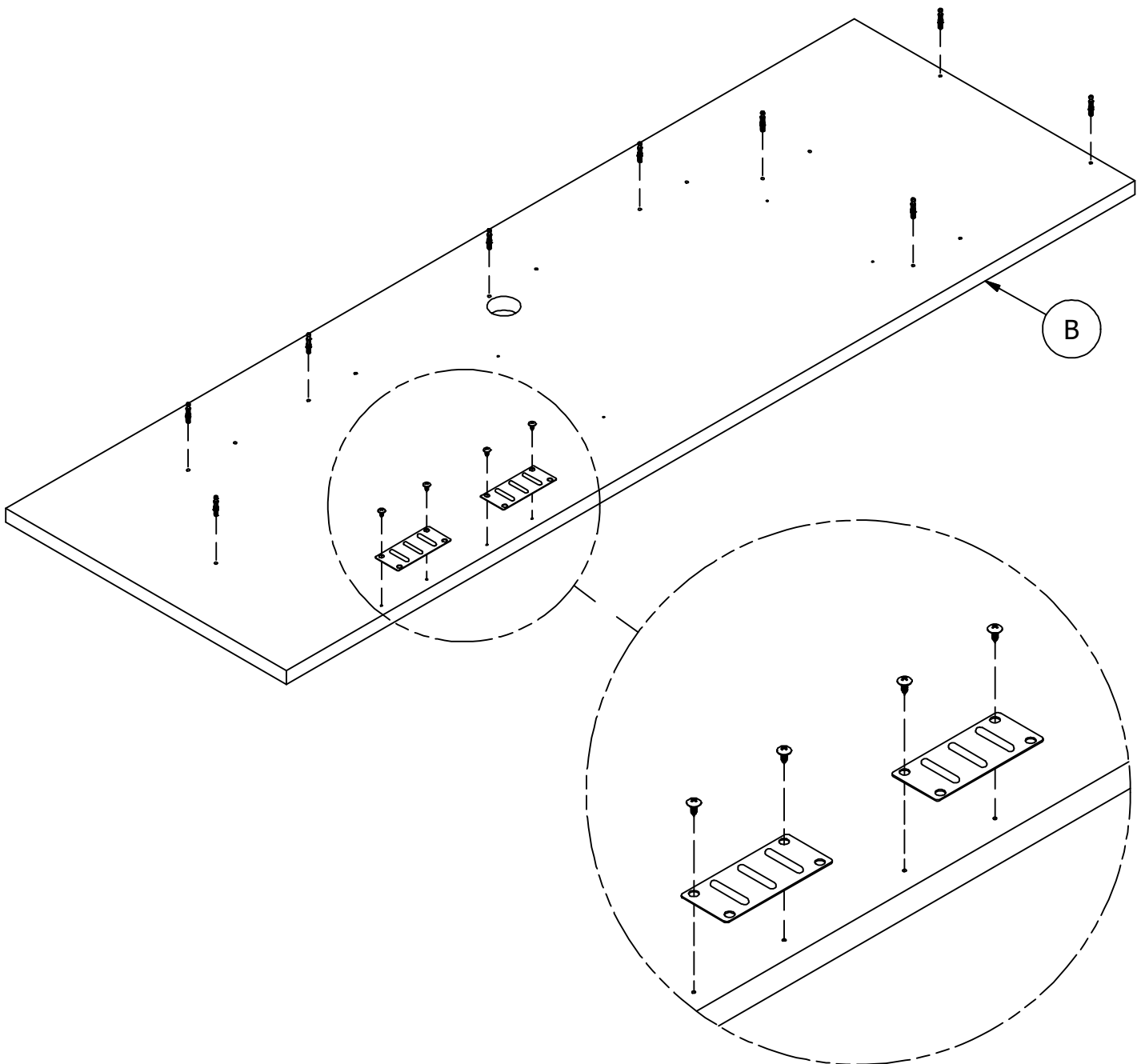
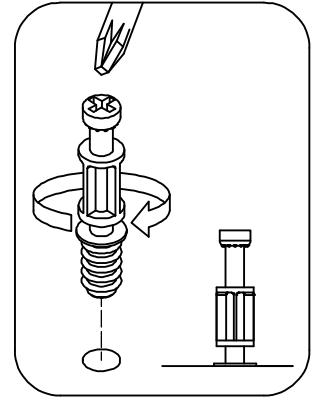

STEP 46

Assemble Panels

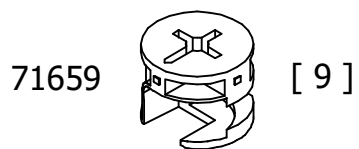

KD Cam



Cover Cap

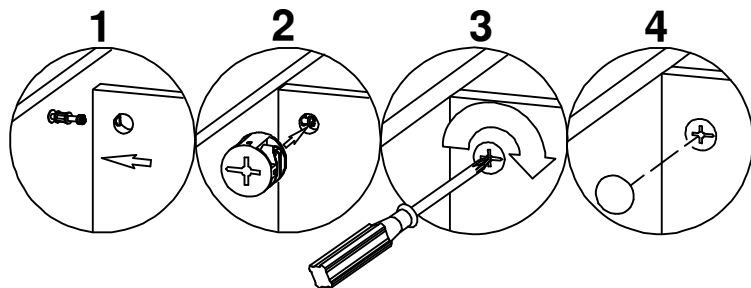

How to Tighten
KD Cams

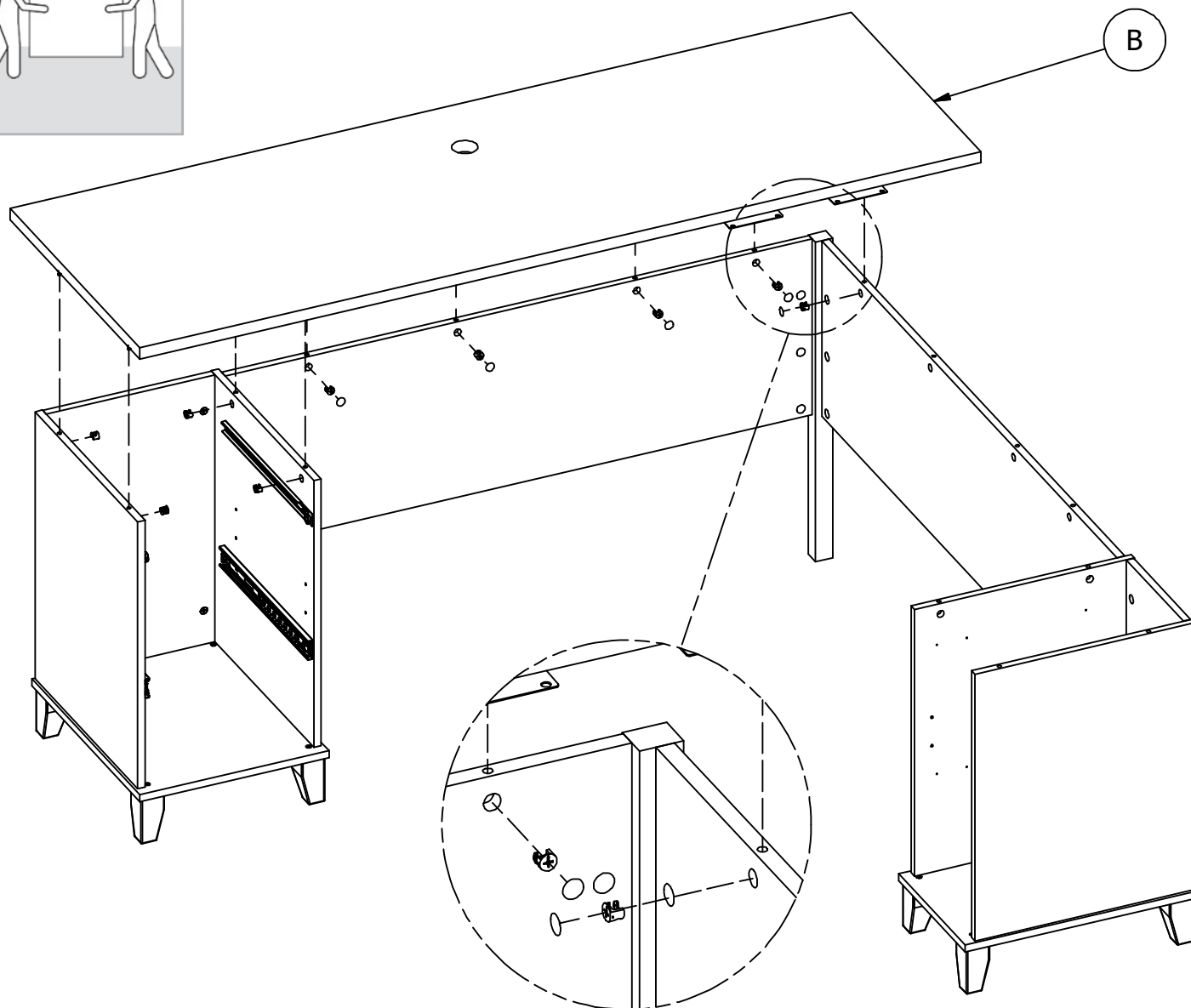
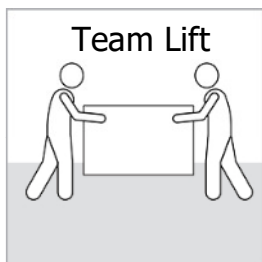

STEP 47

Prepare Panel

H72988

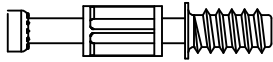

KD Bolt

[7]

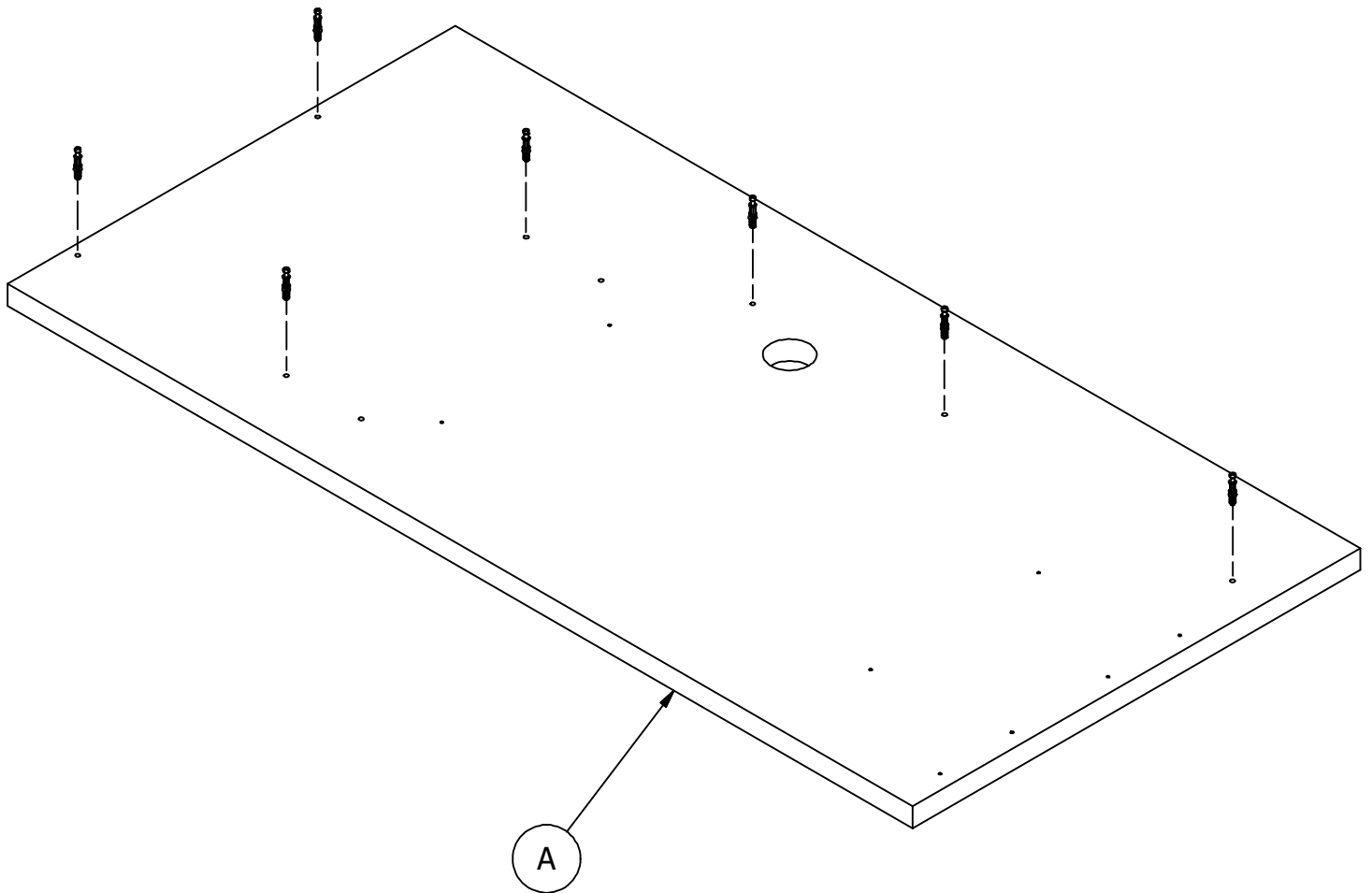
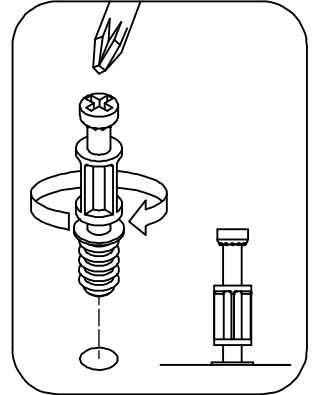

STEP 48

Attach Keyboard Hardware

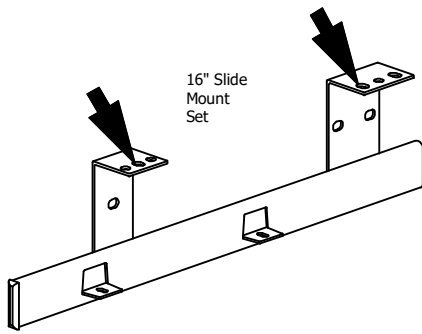

Q92805

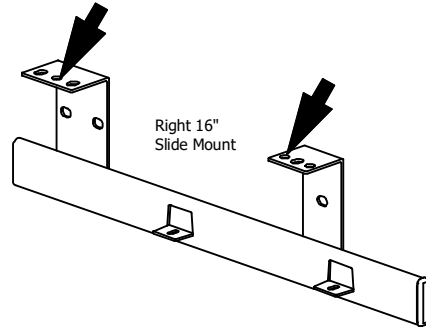

[1]

Q92805

[1]

H35251

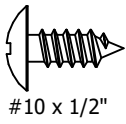

[4]

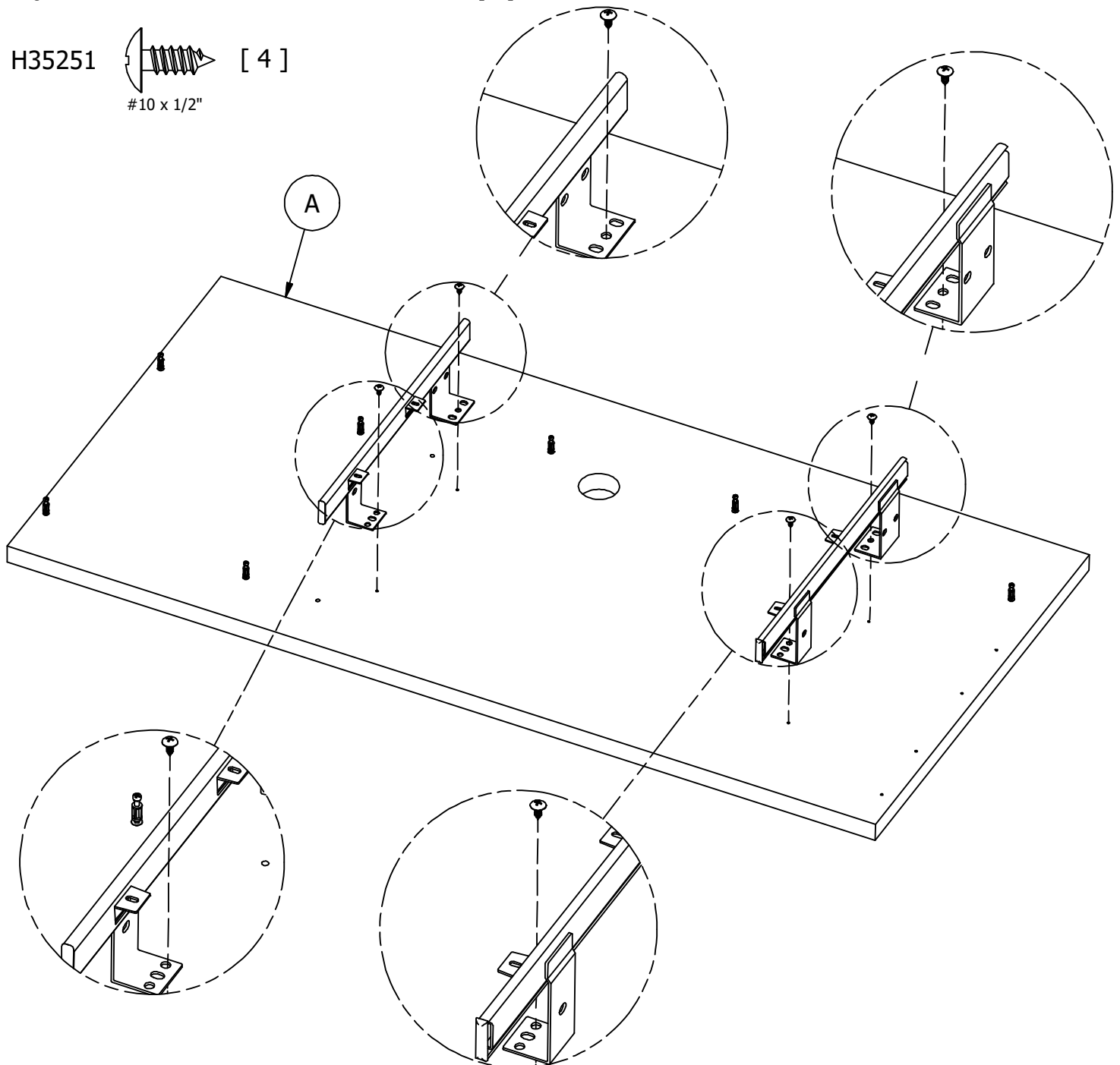

STEP 49

Assemble Panels

H71659 [7]
KD Cam

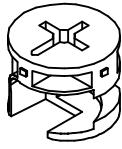

KD Cam

[7]
Cover Cap

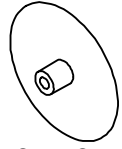

Cover Cap

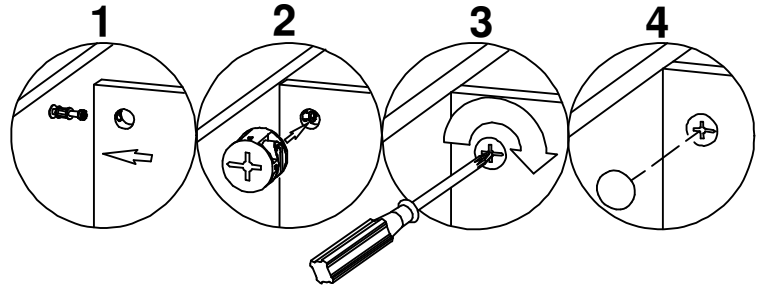

How to Tighten
KD Cams



H35251 [4]
#10 x 1/2"

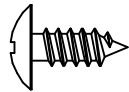

#10 x 1/2"

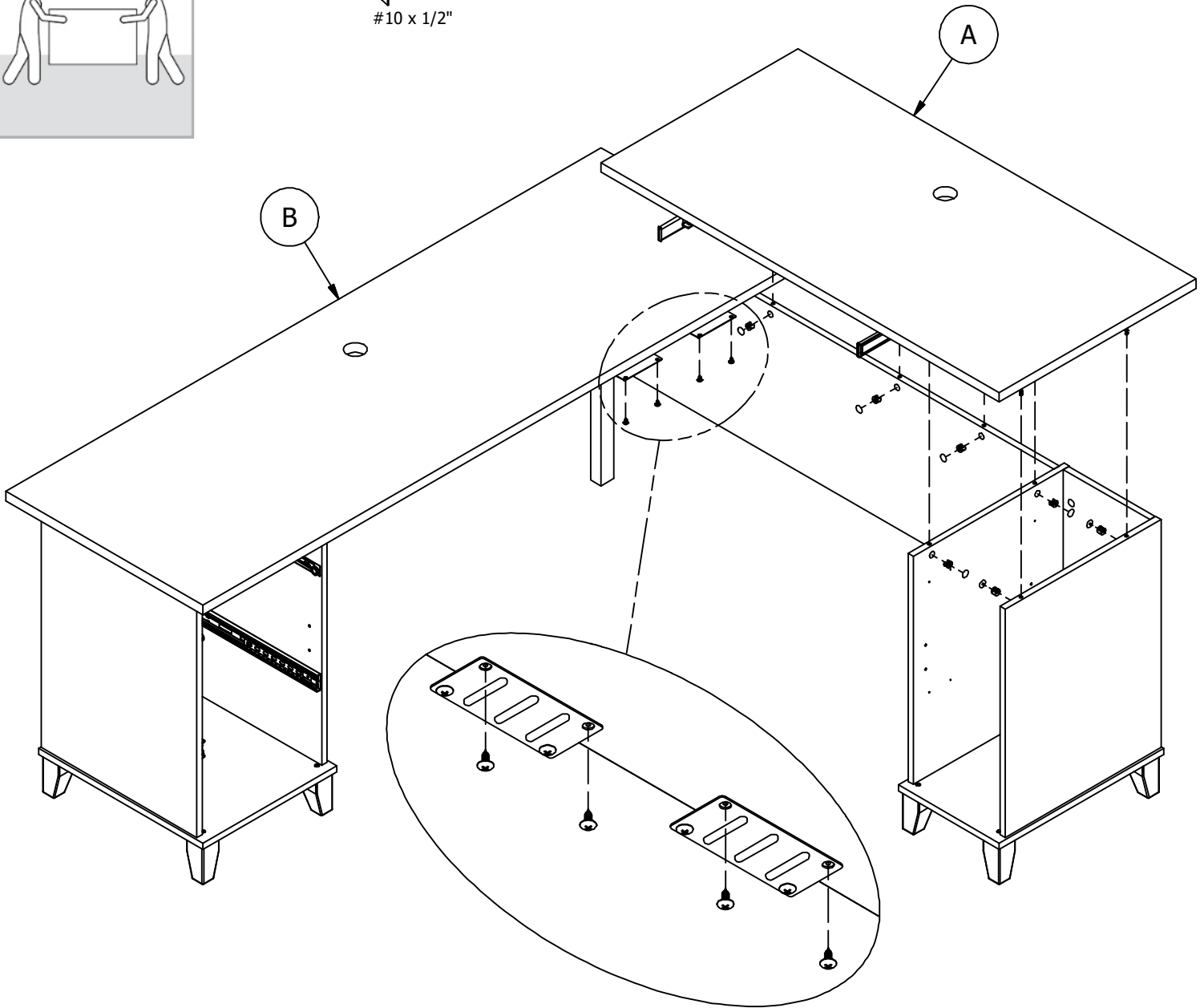

STEP 50

Assemble Adjustable Shelf

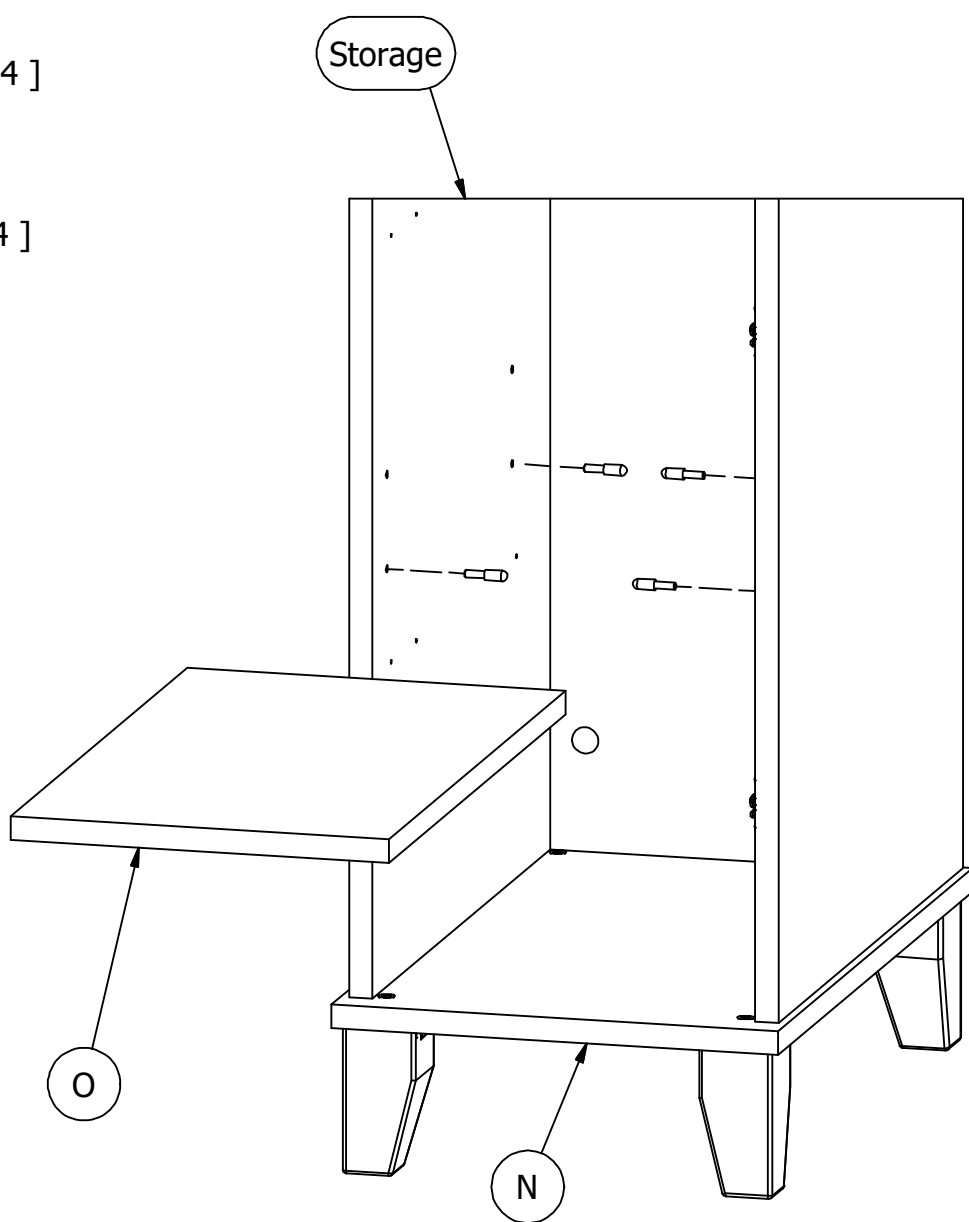
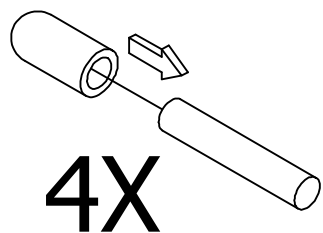
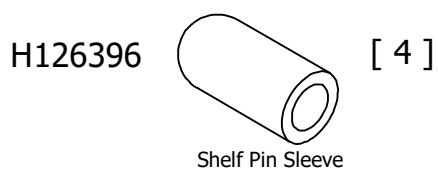
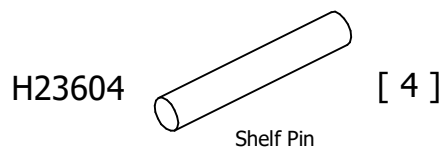
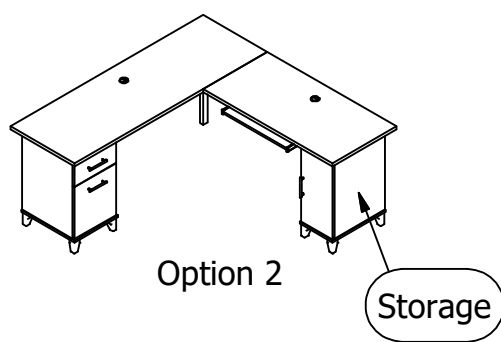
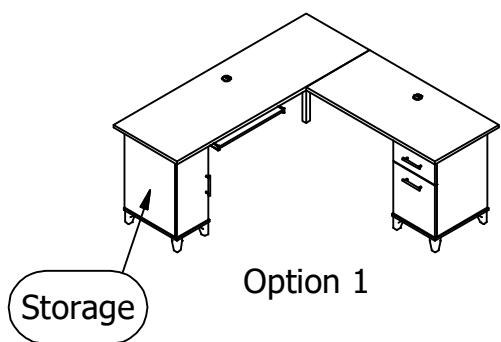

STEP 51

Assemble and Adjust Door

How to Adjust
Door Hinges

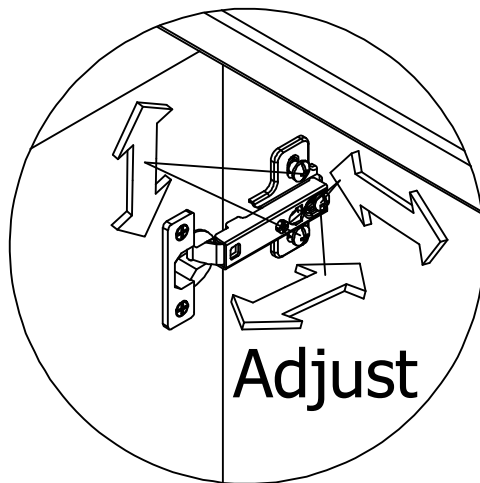
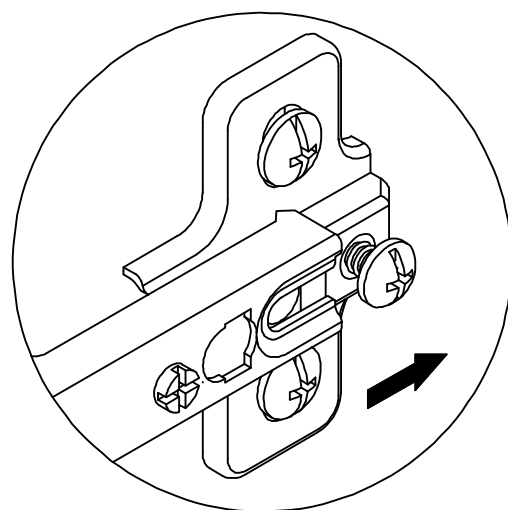
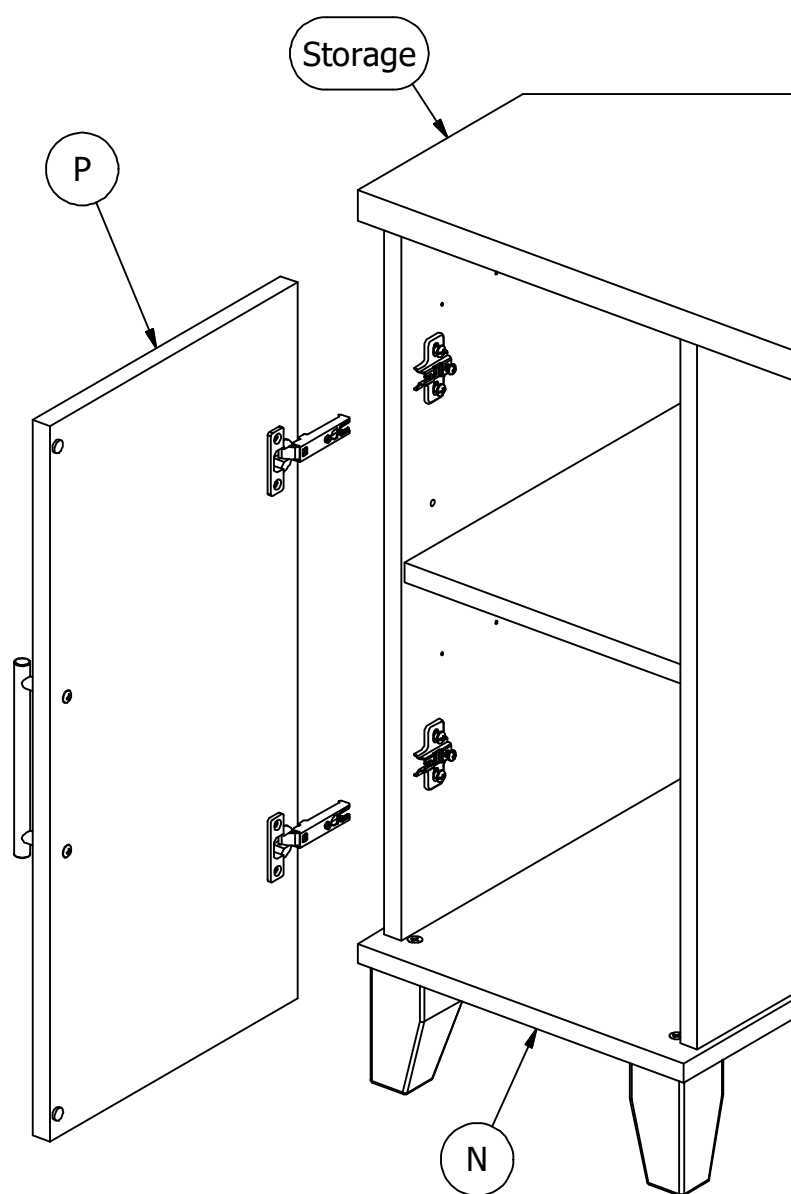
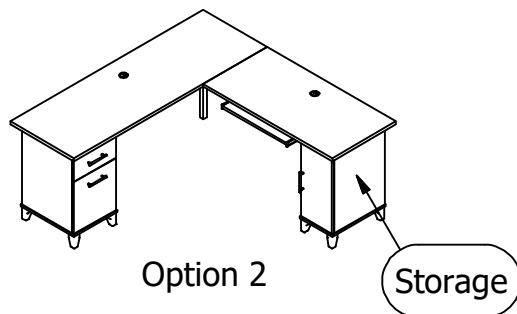
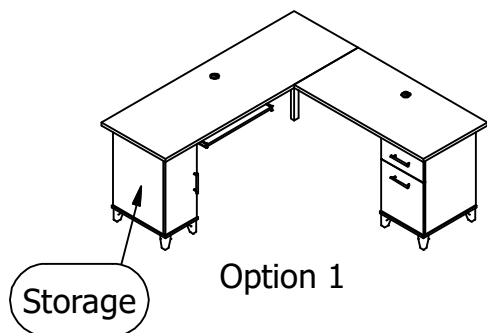

STEP 52

Assemble Keyboard Shelf

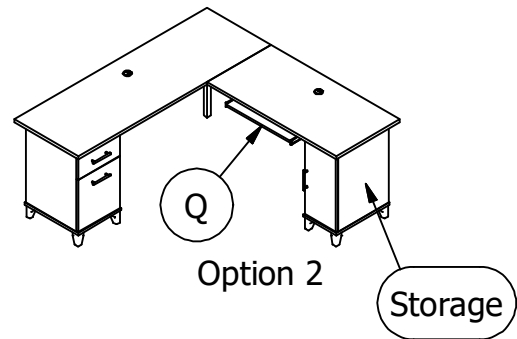
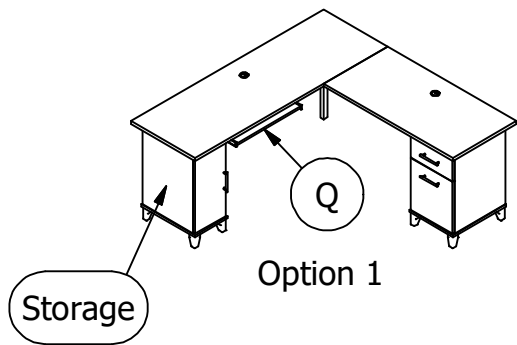

H35251 [4]
#10 x 1/2"

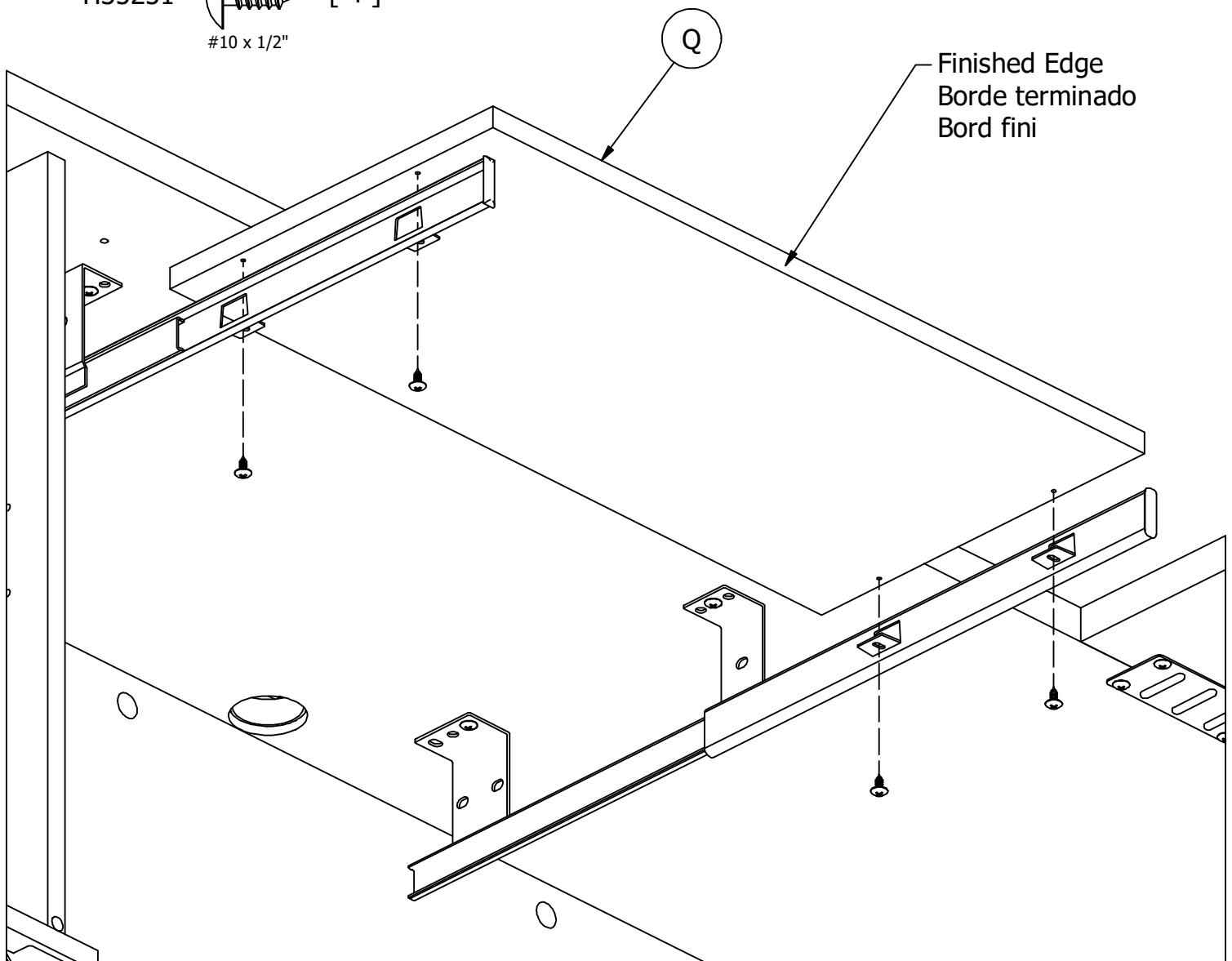

STEP 53

Insert Drawers

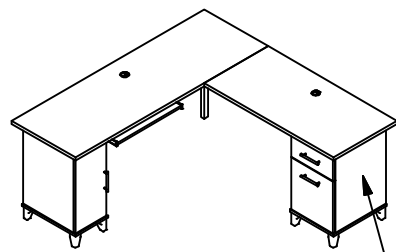

Option 1

Files

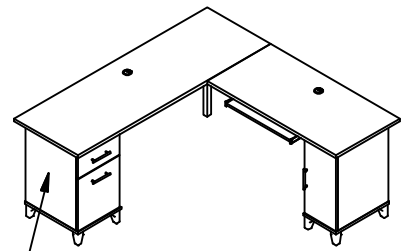

Option 2

Files

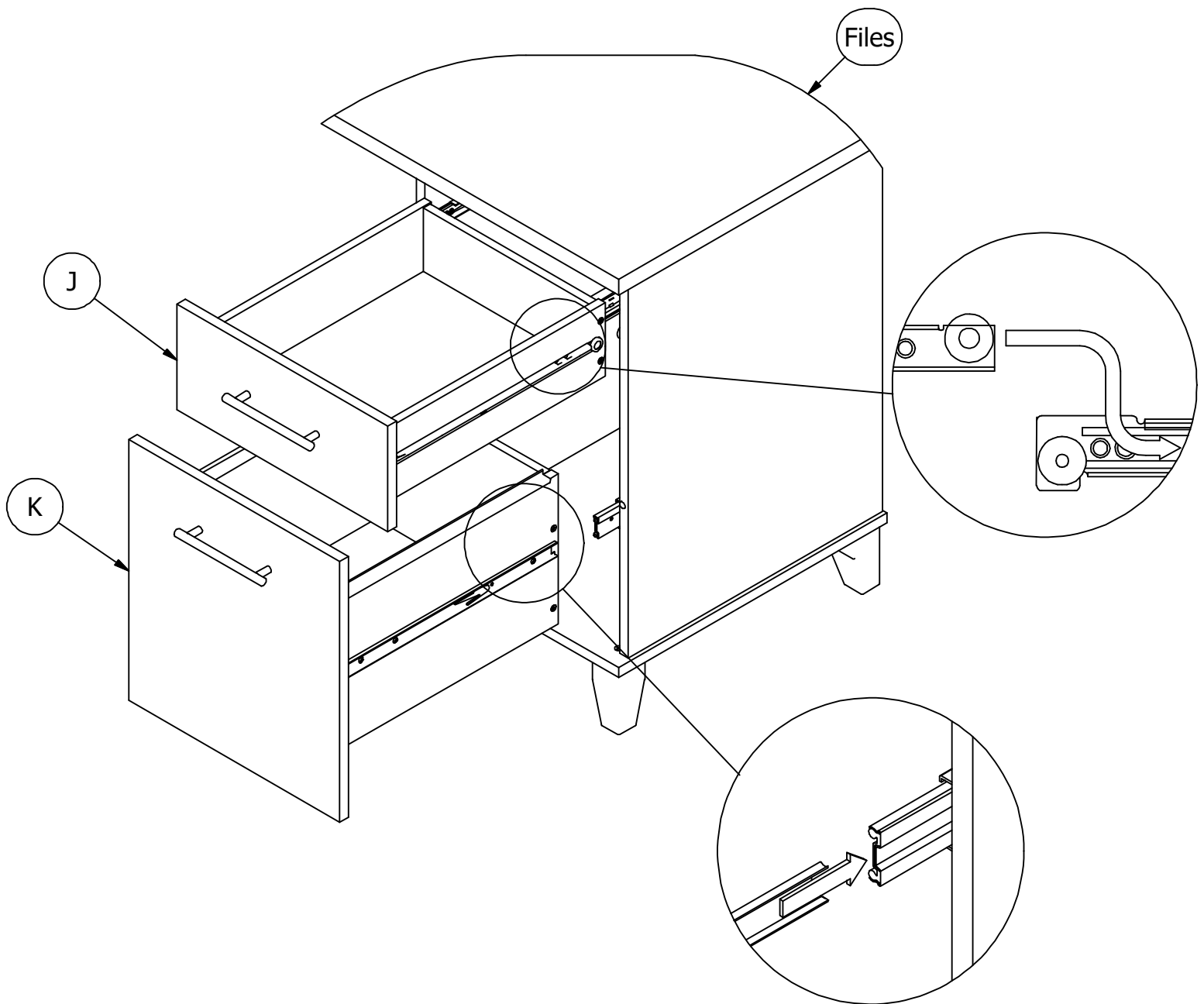

DRAWER FRONT VIEW

How to Adjust
Drawer Fronts

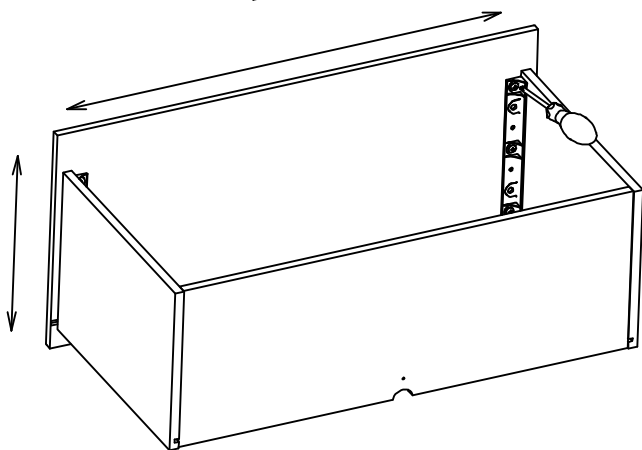
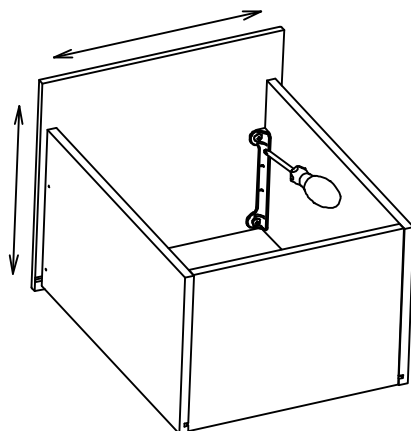
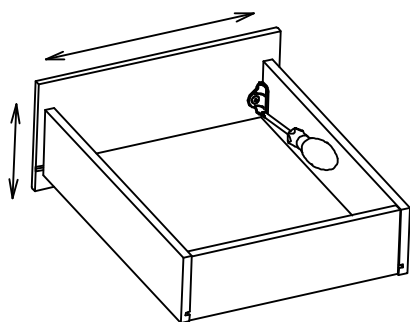
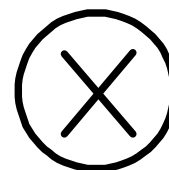
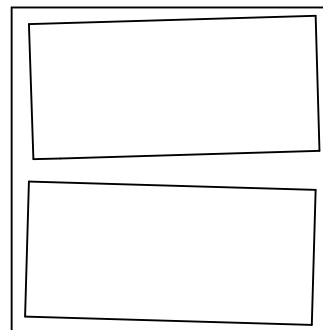
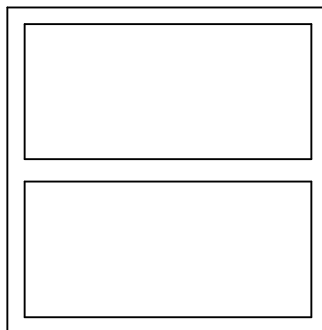

REQUIRED TOOL: PHILLIPS SCREWDRIVER

HERRAMIENTA REQUERIDA: DESTORNILLADOR PHILLIPS
OUTIL REQUIS: TOURNEVIS CRUCIFORME



1. LOOSEN SCREWS.
2. ADJUST DRAWER FRONTS.
3. TIGHTEN SCREWS.

1. Afloje los tornillos
2. Ajustar frentes de cajón
3. Apriete los tornillos

1. Desserrer les vis
2. Ajuster les façades des tiroirs
3. Serrer les vis

STEP 55

Grommet Insert and Loading

Gently clean surfaces with a damp sponge eraser.

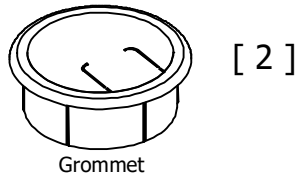

How to Clean
the Surface

Maximum Weight: 15 Lbs.
Peso Máximo: 15 Libras
Poids Maximum: 6.8 kilogramme

Maximum Weight: 200 Lbs.
Peso Máximo: 200 Libras
Poids Maximum: 90 kilogramme

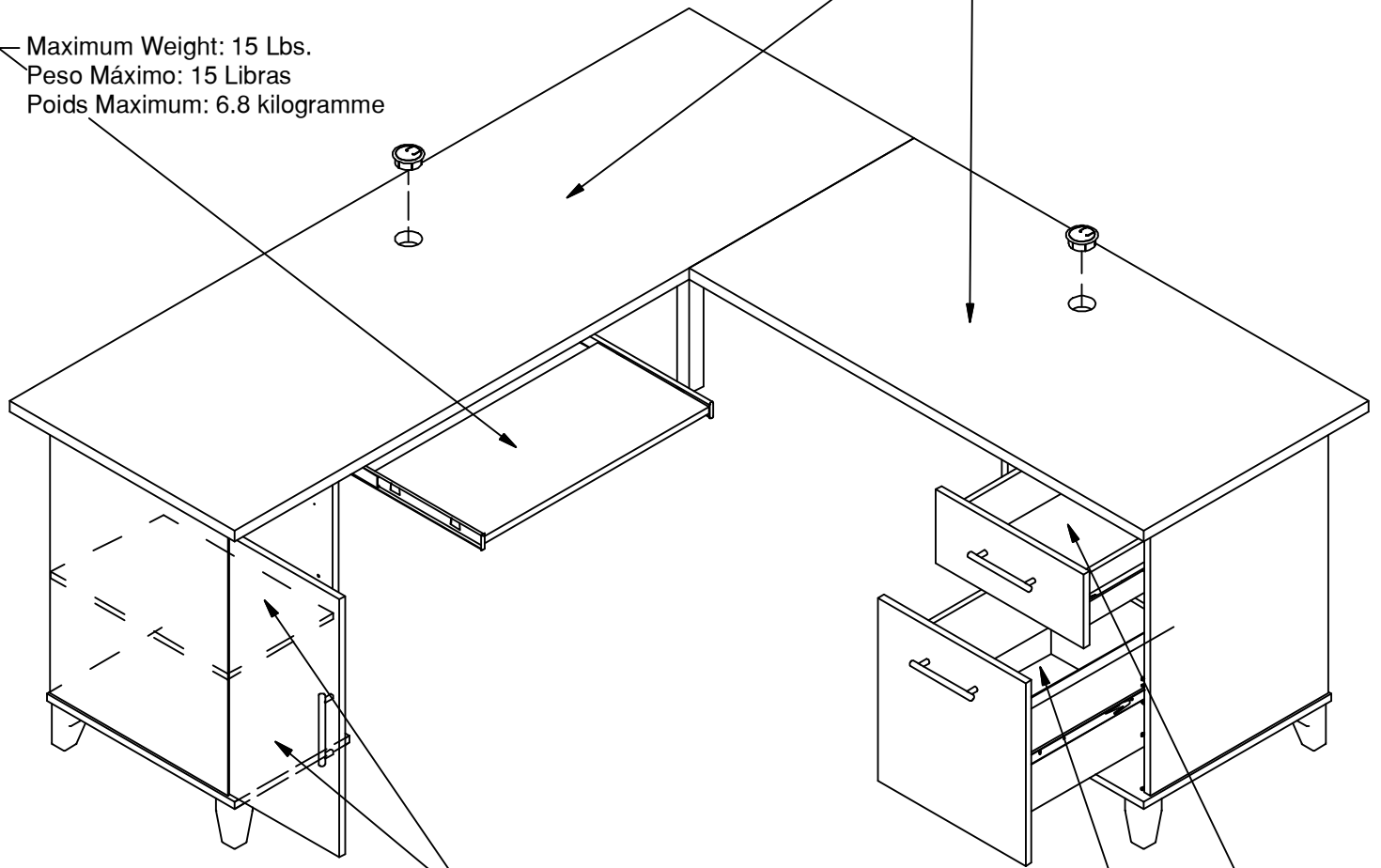

Maximum Weight: 30 Lbs.
Peso Máximo: 30 Libras
Poids Maximum: 13.5 kilogramme

Maximum Weight: 30 Lbs.
Peso Máximo: 30 Libras
Poids Maximum: 13.5 kilogramme

Maximum Weight: 15 Lbs.
Peso Máximo: 15 Libras
Poids Maximum: 6.8 kilogramme

Congratulations! You are all done. If you have any questions or concerns, please call.

PARTS LIST

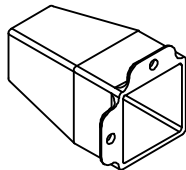
193807  [8]
Foot

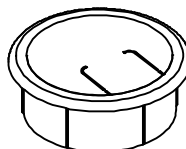
95624  [2]
Grommet

M [1]

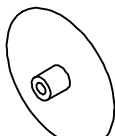
H73619  [28]
Cover Cap

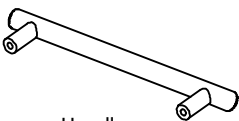
H196000  [3]
Handle

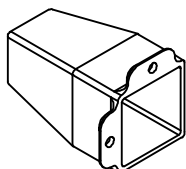
H195789  [8]
Foot

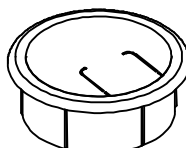
H151407  [2]
Grommet

H193368  [28]
Cover Cap

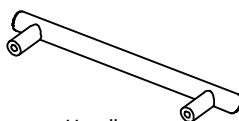
H150001  [3]
Handle

PARTS LIST

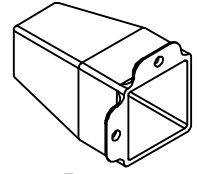

[8]

Foot

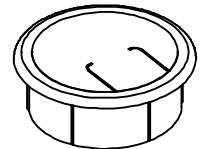

[2]

Grommet

H83021

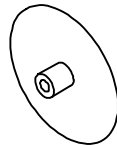

[28]

Cover Cap

H196000

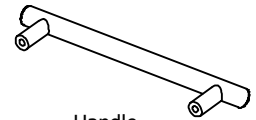

[3]

Handle

H200227

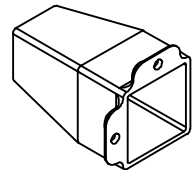

[8]

Foot

H118700

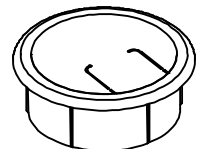

[2]

Grommet

H73620

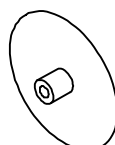

[28]

Cover Cap

H200226

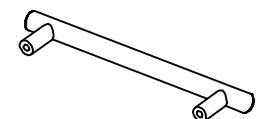

[3]

Handle

PARTS LIST

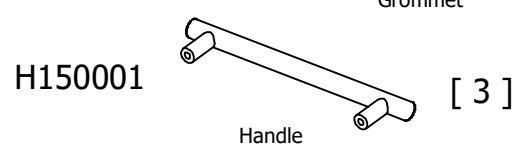
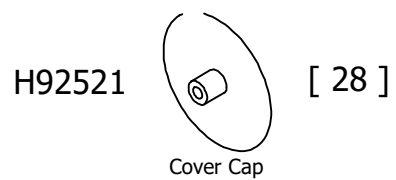
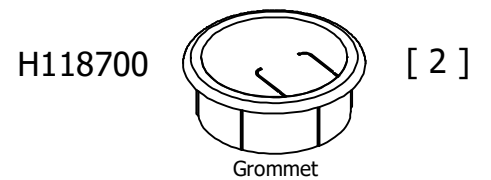
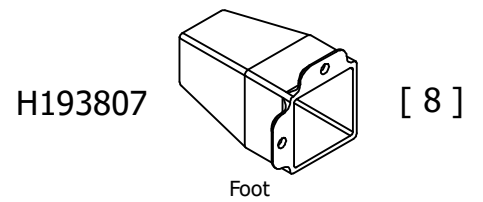
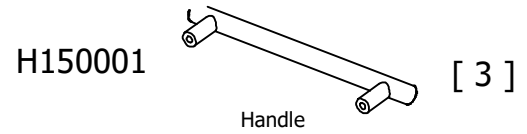
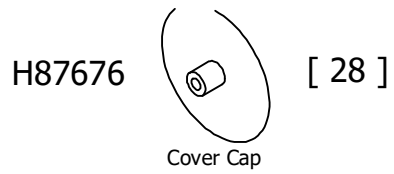
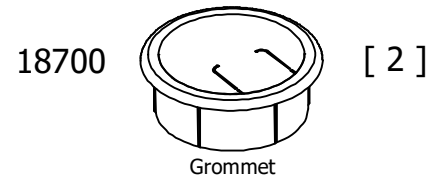
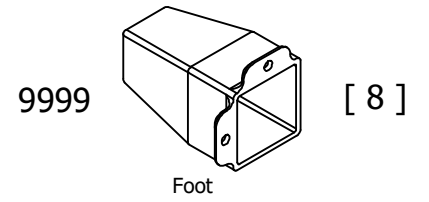

PARTS LIST

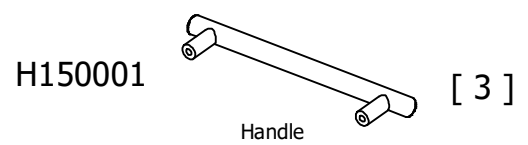
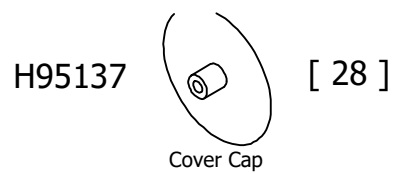
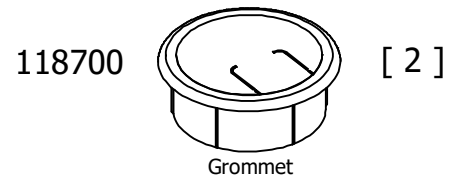
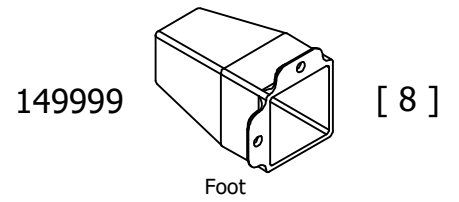
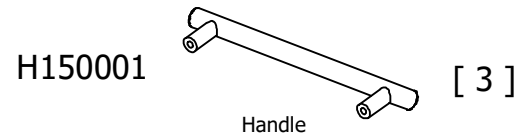
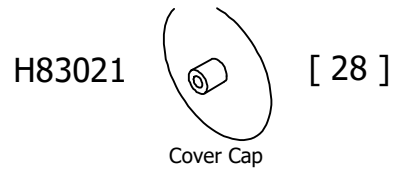
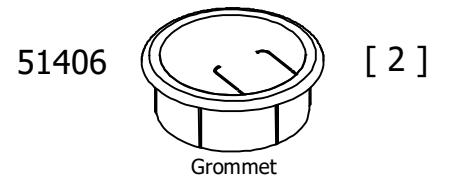
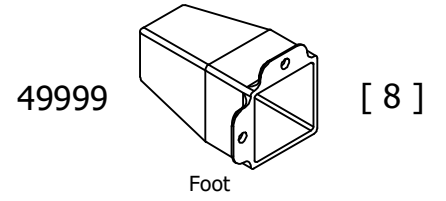

PARTS LIST

