

# Installation Instruction

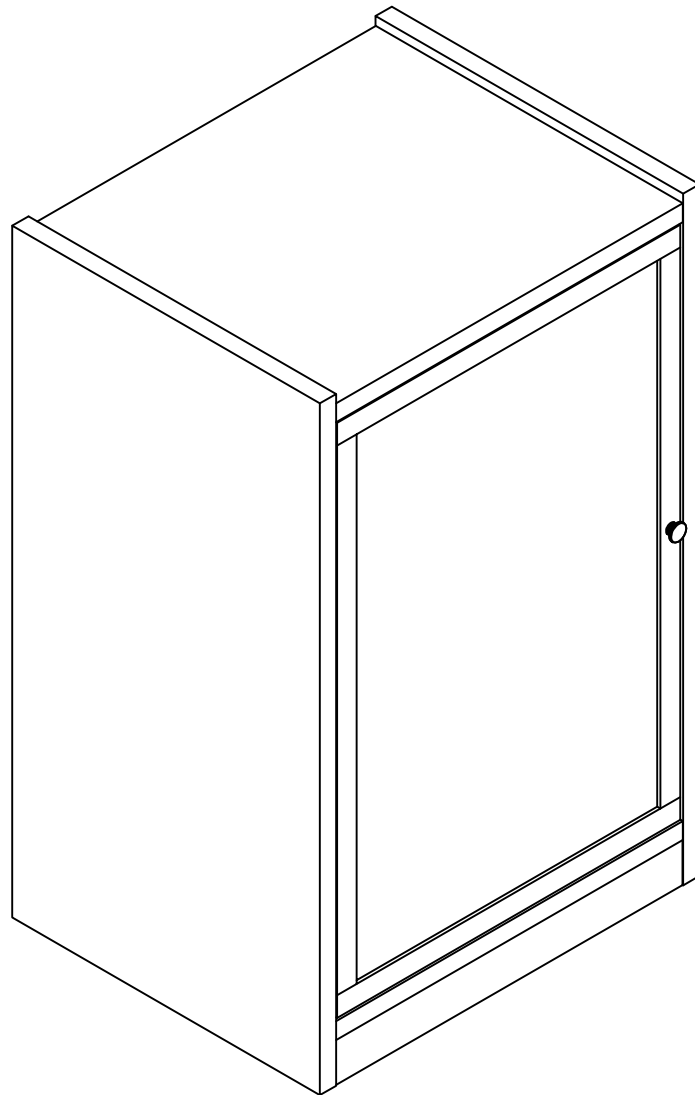

# Assembling

Estimated time for assembly



**45 : 00**

## What you need

- Use the packaging carton as a working surface to prevent product damage during assembly
- Phillips head screwdriver

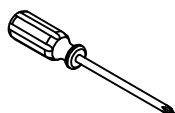

## Weight Limitation



**100**

lbs table top

**| 35**

lbs per

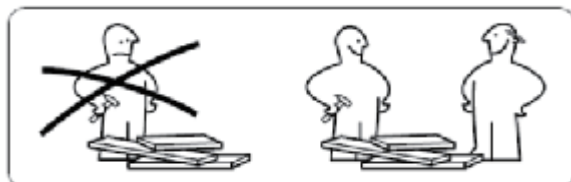

# What' included

Code	Description	Qty
A	Cam Bolt M6X35MM	16
B	Cam Lock 15X9MM	16
C	Wooden Dowel M8X30MM	12
D	Screw M4X40MM	2
E	Screw M3.5X14MM	2
F	Metal shake handhandle	1
G	Nylon Strap	2
H	Screw M3.0X14MM	14
I	Foot nail	8
J	The back button	6
K	Anchor	2
L	The bolt	2
M	Ron absorption	2
N	Metal handle	2
O	Shelf Holder	12
P	Cam Bolt M4X18MM	1

# The Hardwares

A

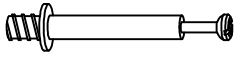

B

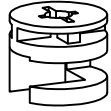

C

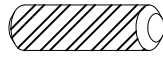

D

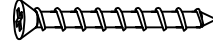

E



F



G

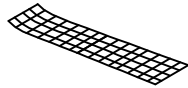

H



I



J

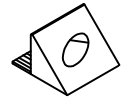

K



L



M

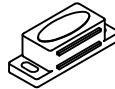

N



O



P



## IMPORTANT:

1. Do not tighten bolts / screws completely until all bolts / screws are lined up and inserted into holes.
2. Do not over tighten screws and bolts to avoid stripping
3. Please use hand tools to assemble this product. Do not use power tools.

# Included Accessories

---

Code	Description	Qty
1	Cabinet Top	1
2	Bottom Panel	1
3	Left Side Panel	1
4	Right Side Panel	1
5	Metal Door	1
6	Movable laminate	3
7	Decorative plate	2
8	Backboard	1

# The Accessoriess

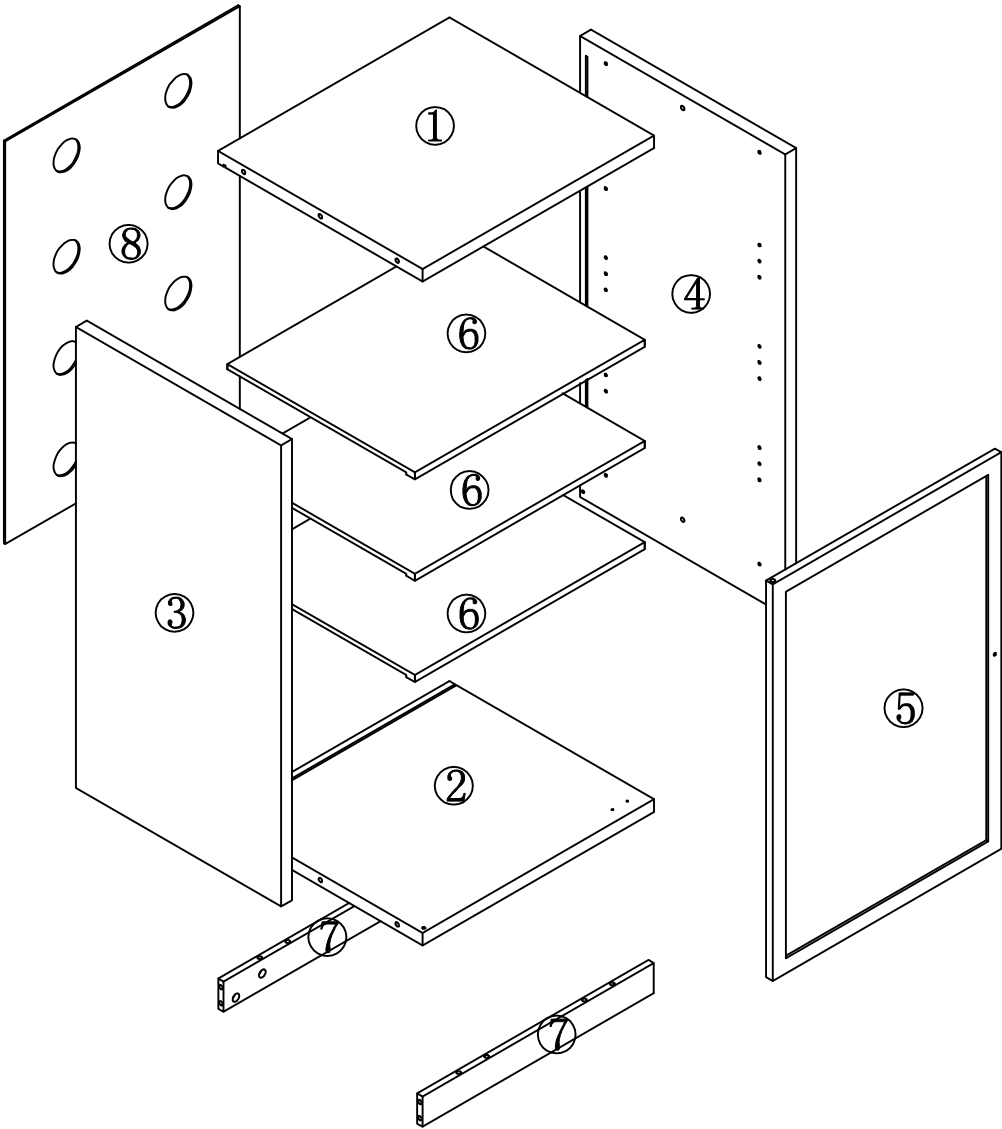

# Step 1

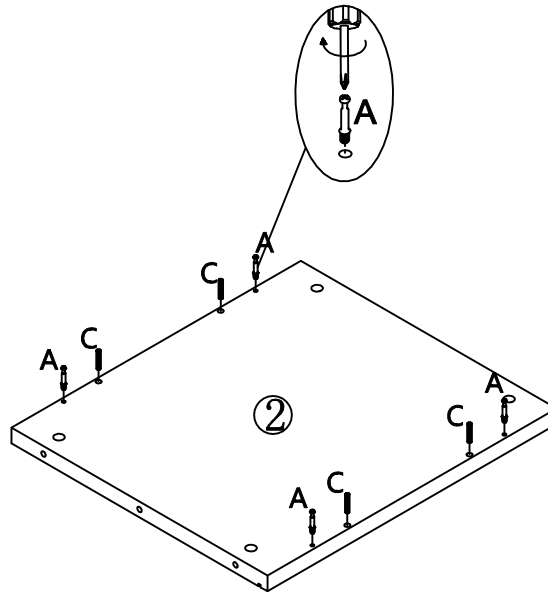
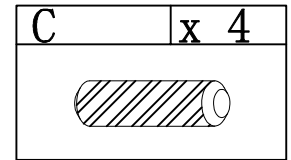
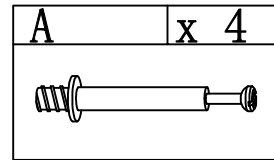

# Step 2

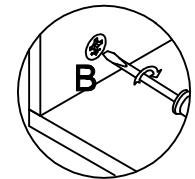
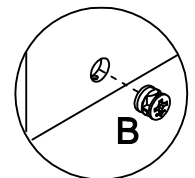
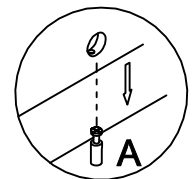
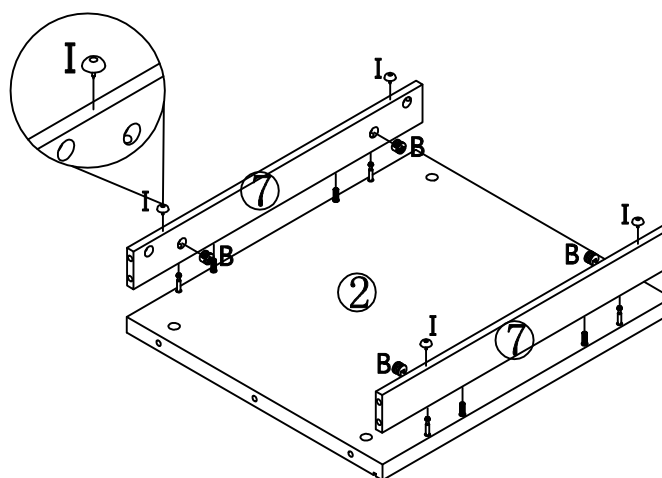
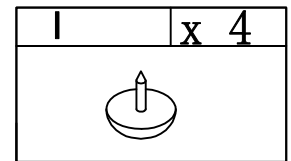
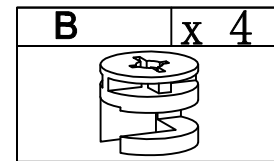

# Step 3

H	x 4
	

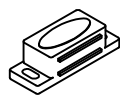
M	x 2
	

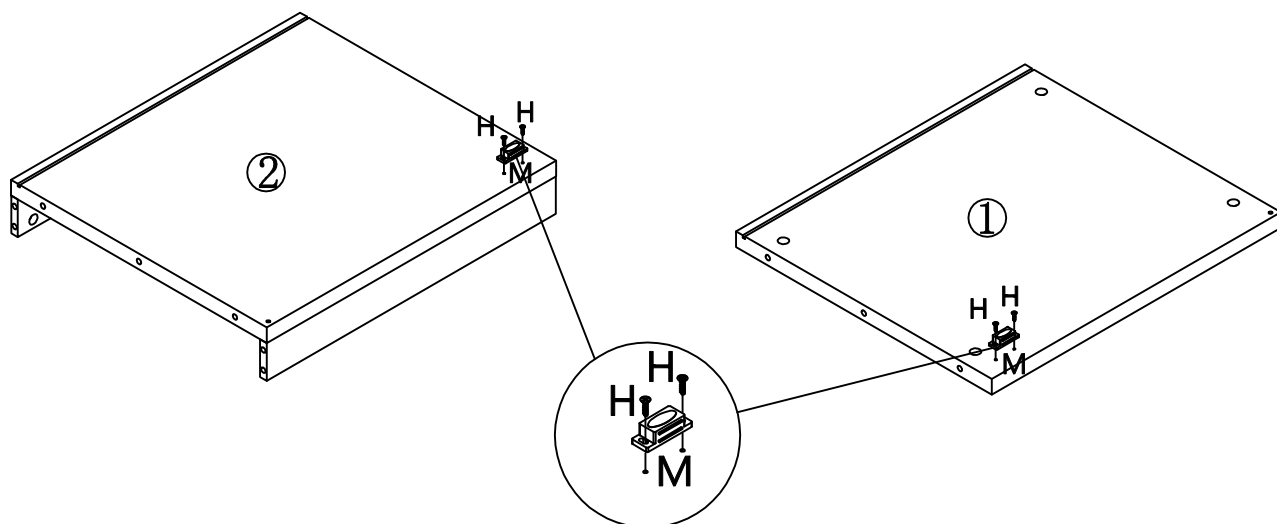

# Step 4

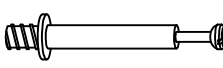
A	x 12
	

I	x 4
	

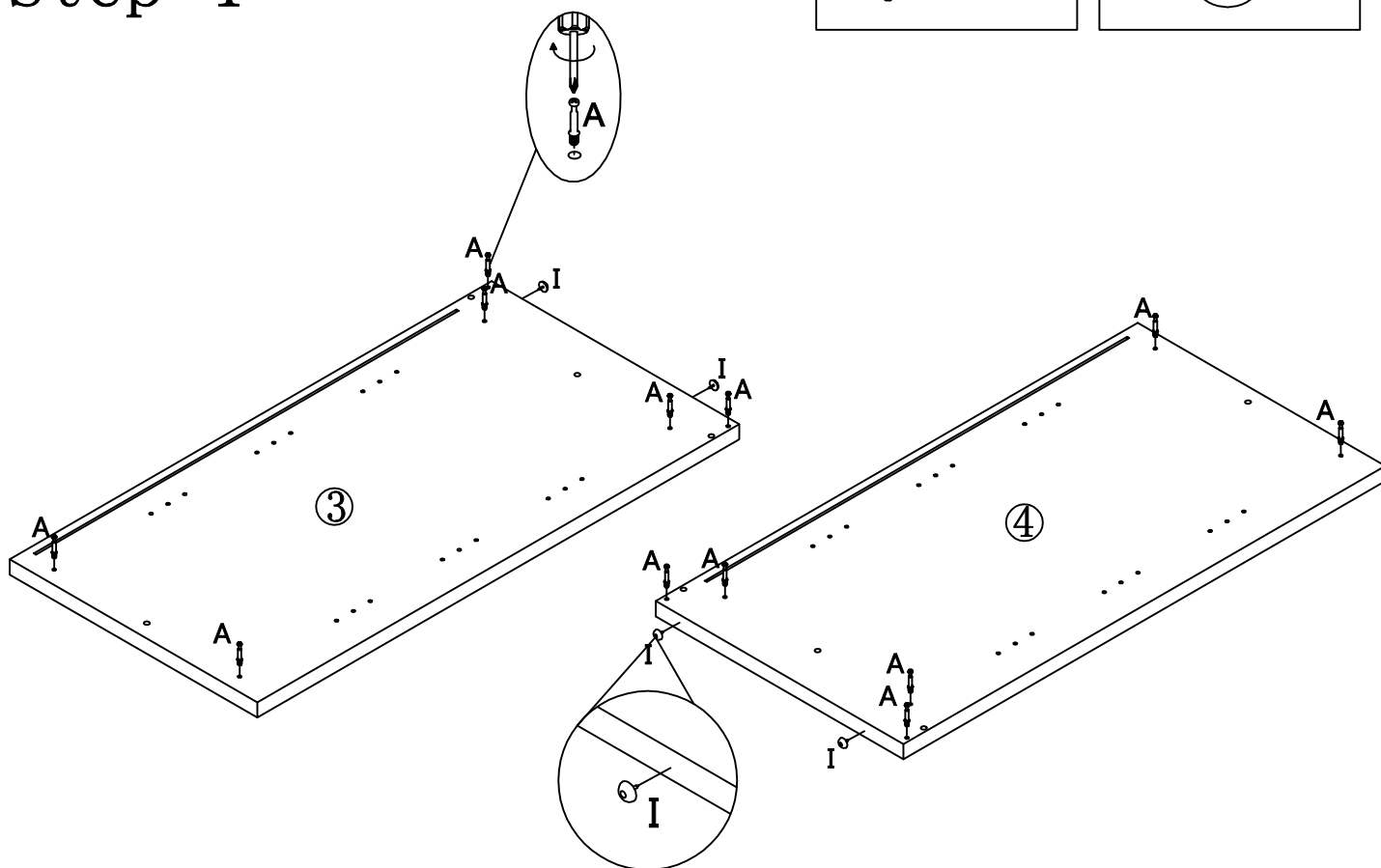

# Step 5

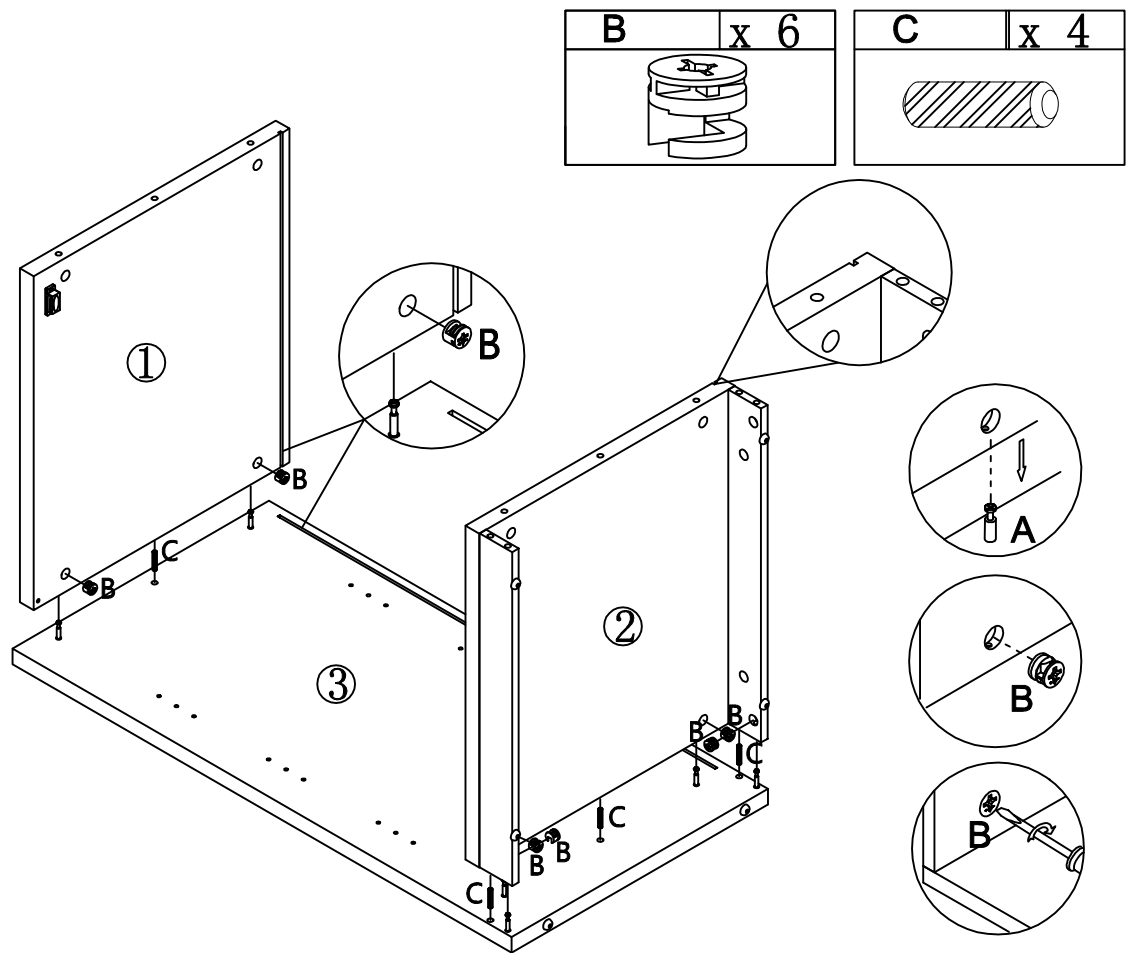

# Step 6

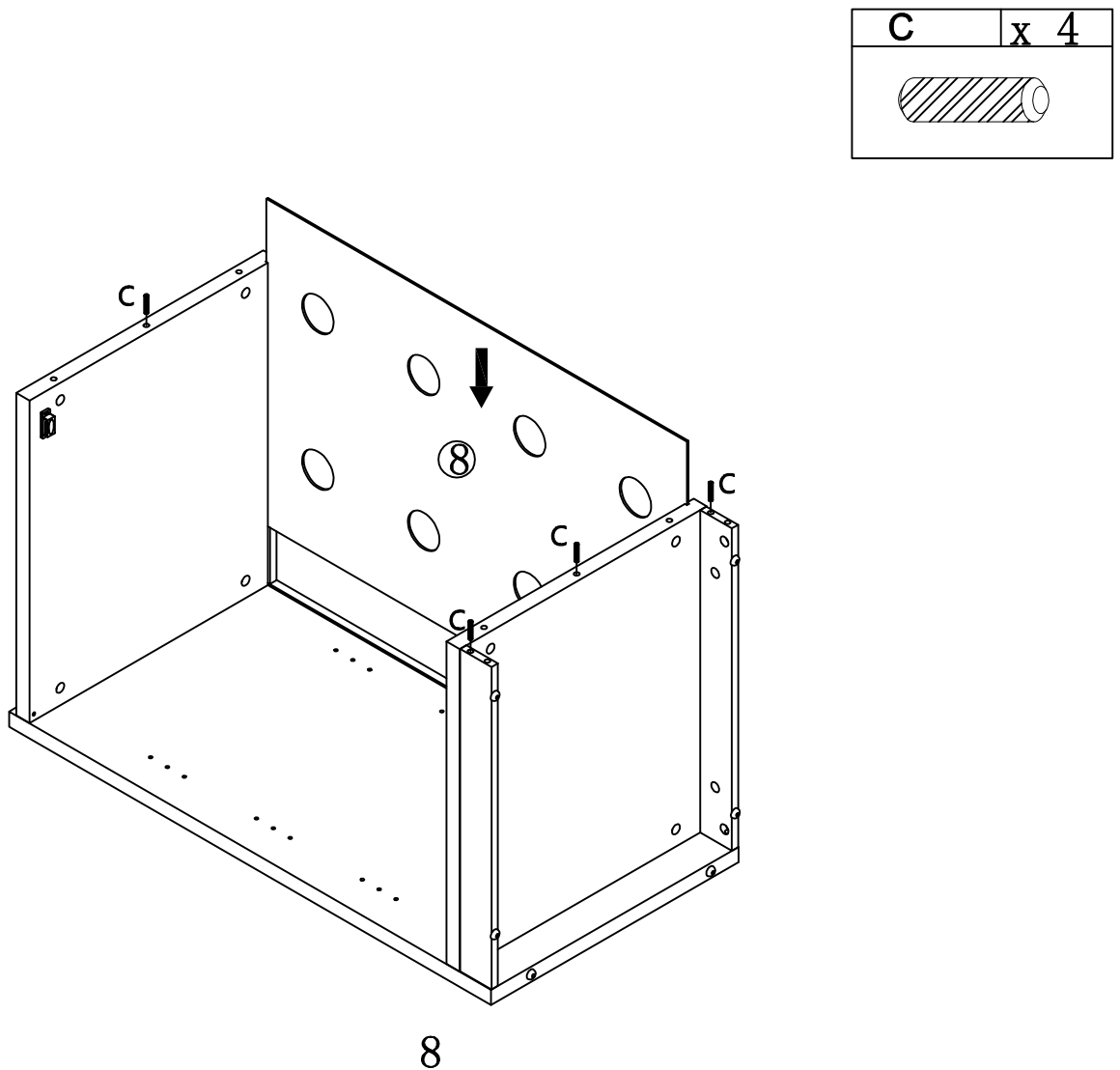

# Step 7

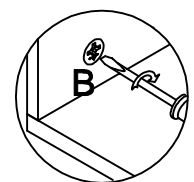
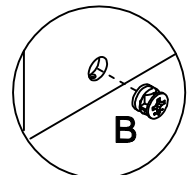
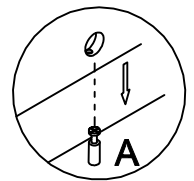
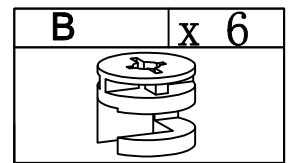
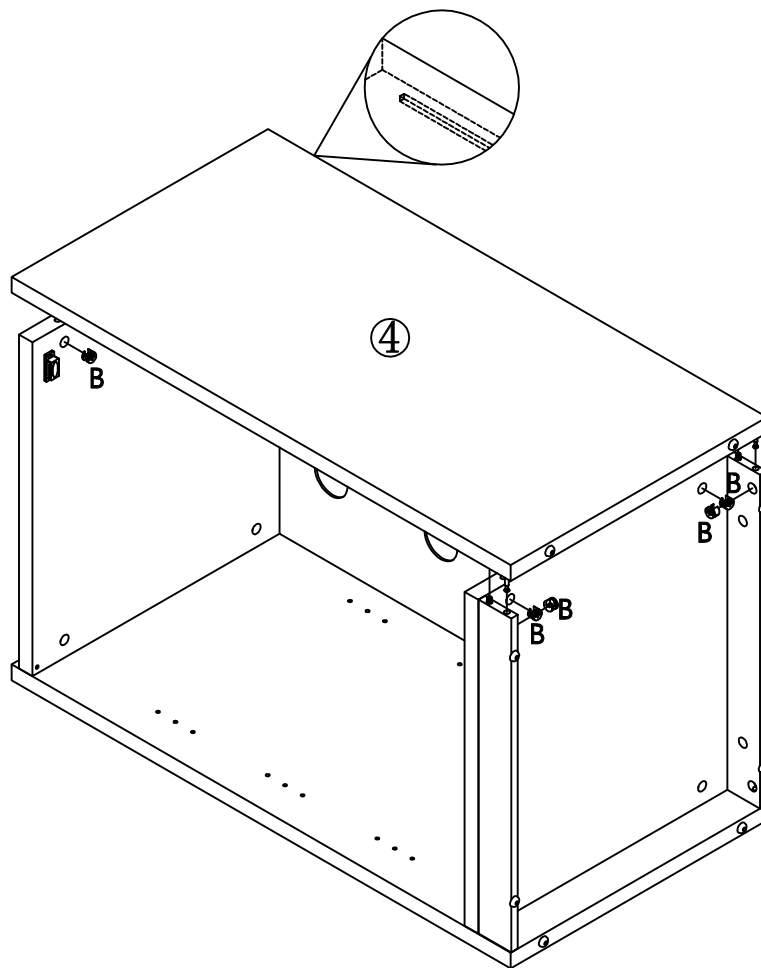

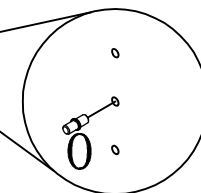
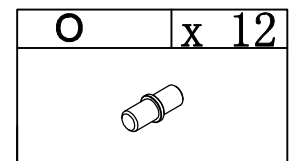
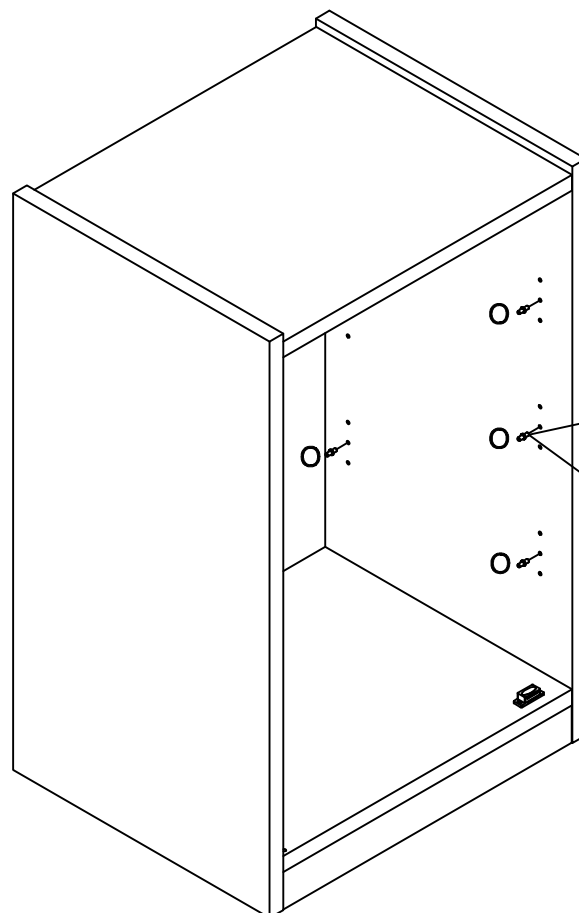

# Step 8

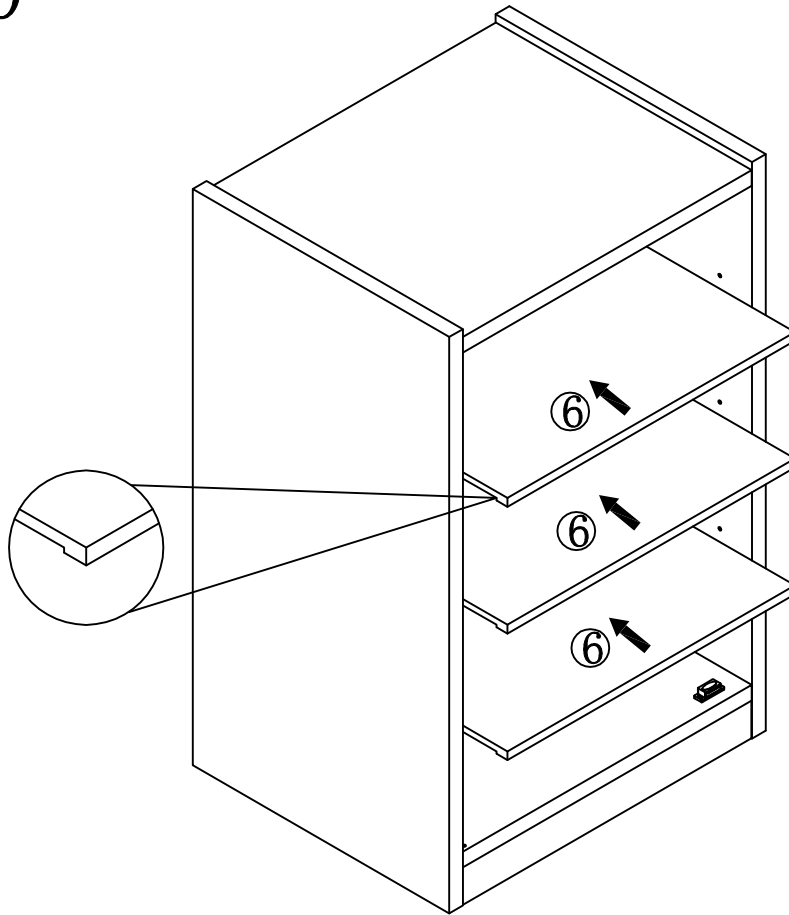

# Step 9



H	x 4	L	x 2	N	x 2
					

# Step 10

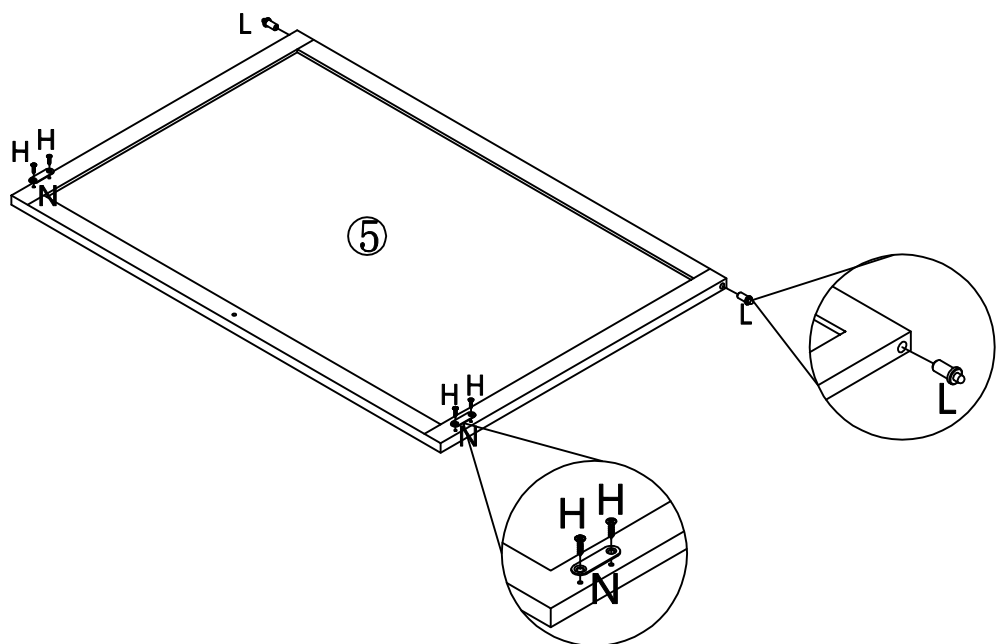

# Step 11

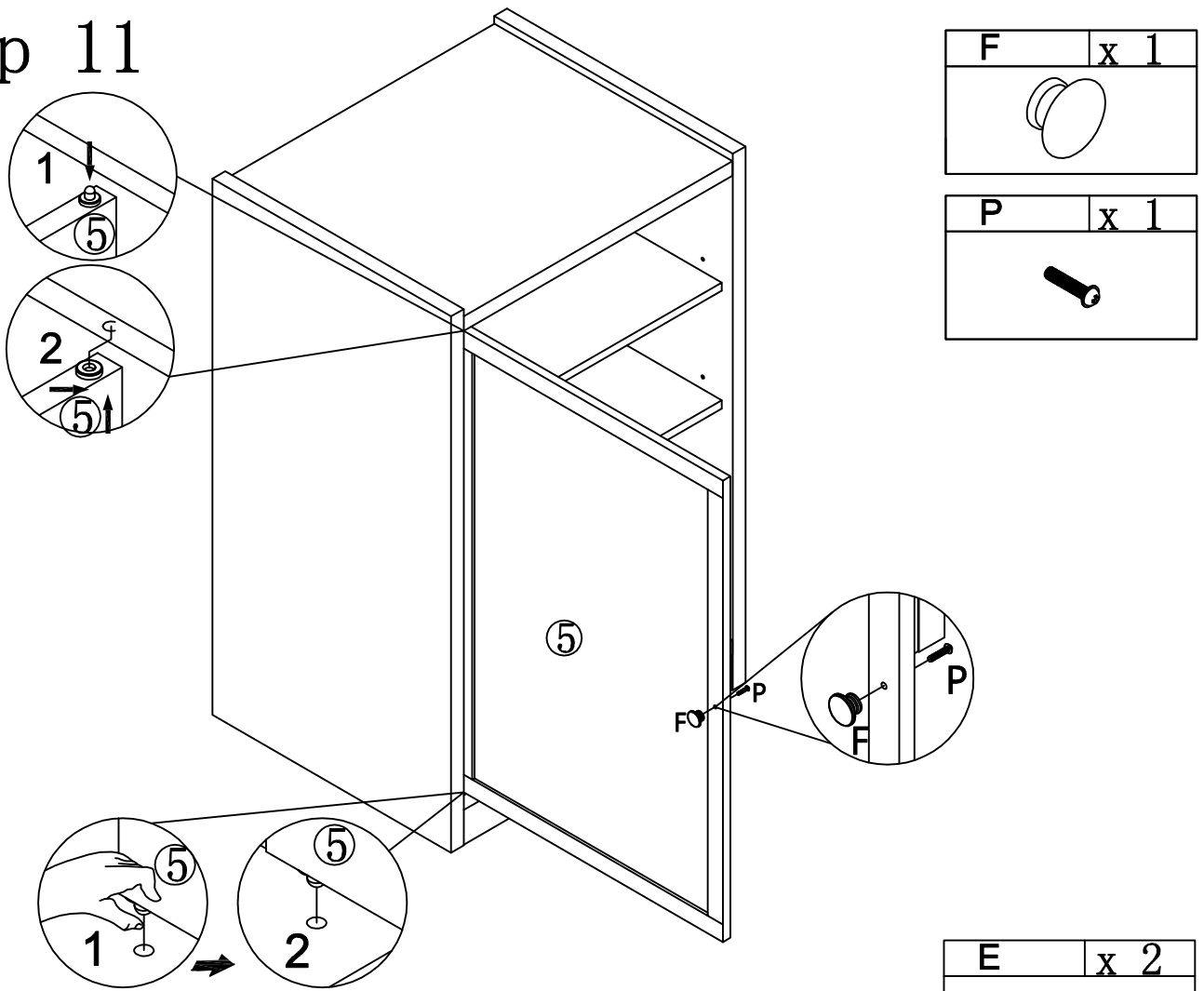

# Step 12

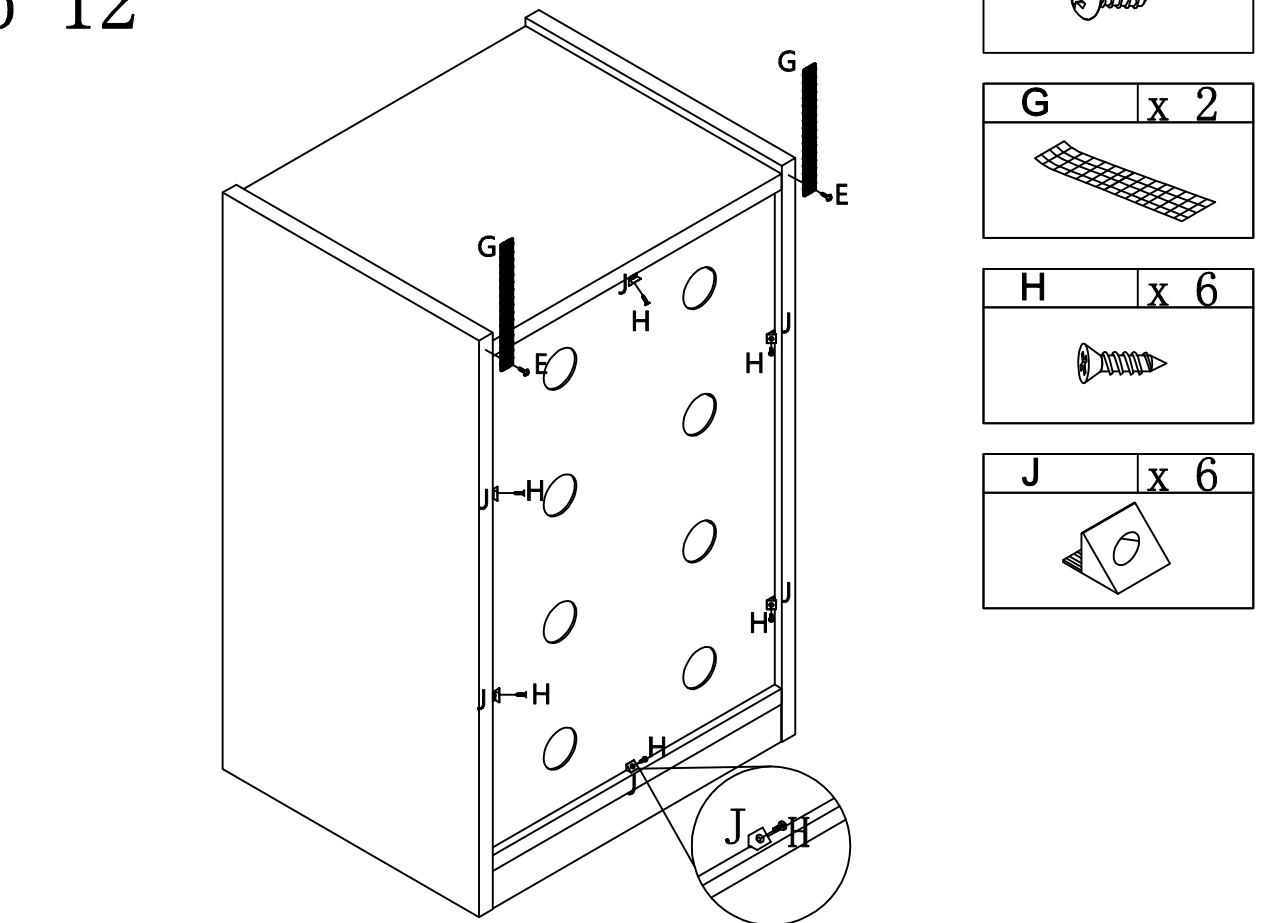

# Step 13

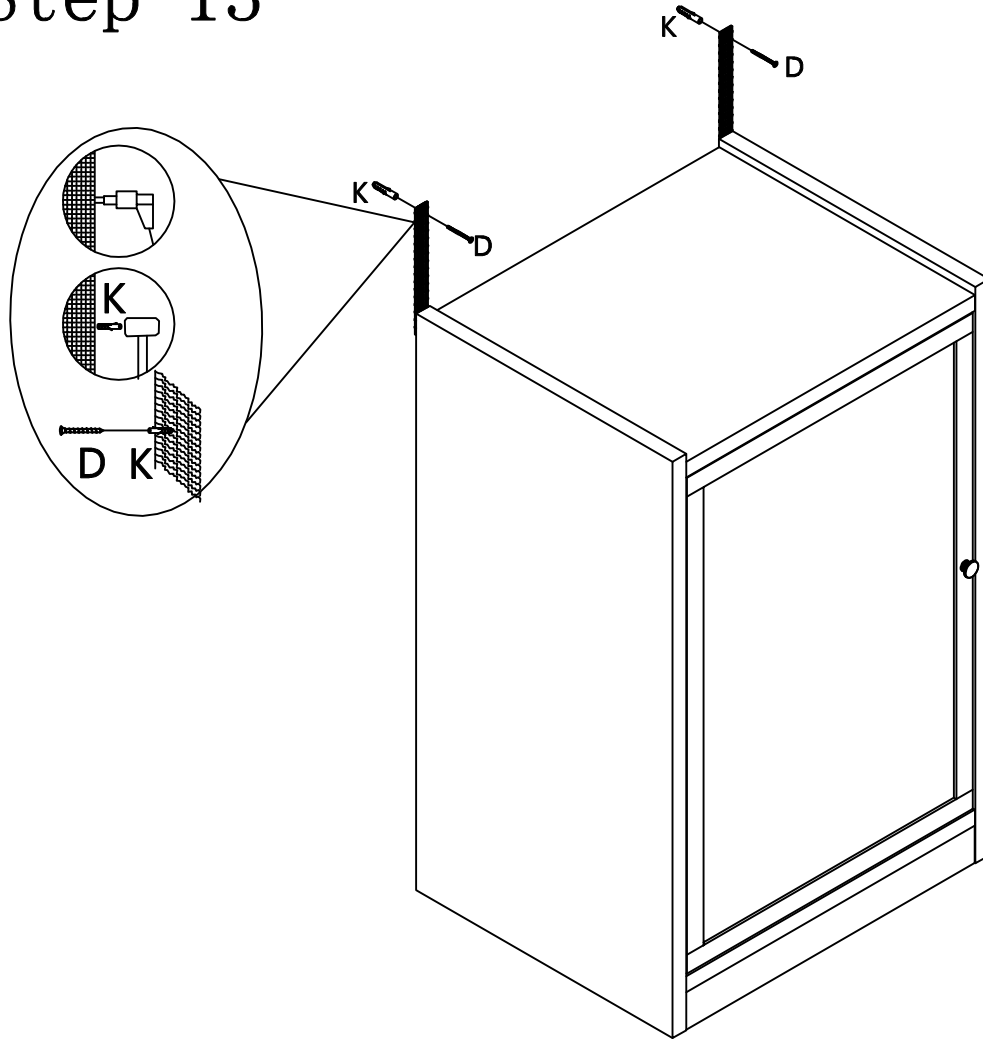

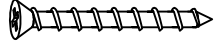
D	x 2
	

K	x 2
