

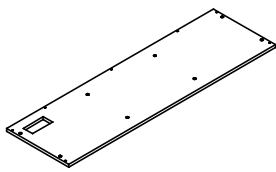

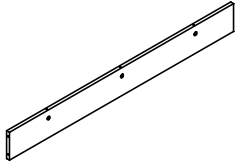

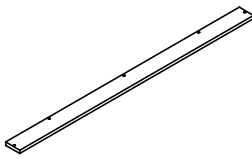

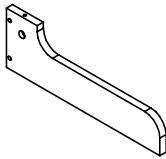

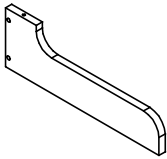

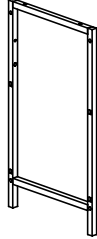
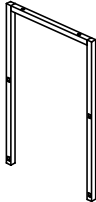
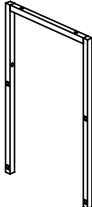
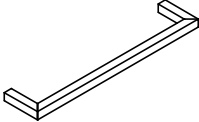
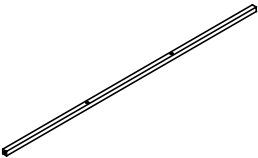
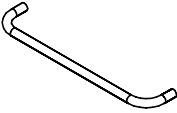
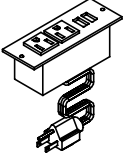
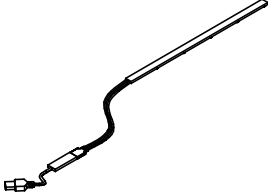

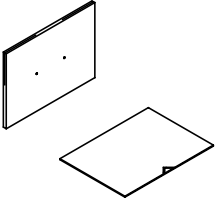
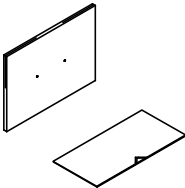



# Assembling Instruction

Attention: Do not tighten the screws until all of them are in right positions

1  X1	2  X1	3  X1	4  X1	5  X1
6  X1	7  X1	8  X1	9  X1	10  X1
11  X2	12  X1	13  X1	14  X1	15  X3
16  X5	17  X1			
A  X5	B  X5	C  M6X23 X20	D  M5X40 X11	E  M4X10 X12
F  M4X12 X2	G  M6 X4	H  X6	J  M6X30 X2  M4X50 X2 X1	L  X6
R  X6	 M4	 M3		

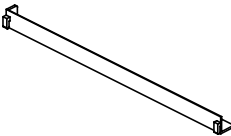
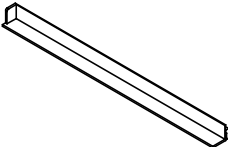
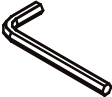
1

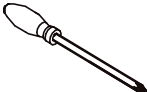
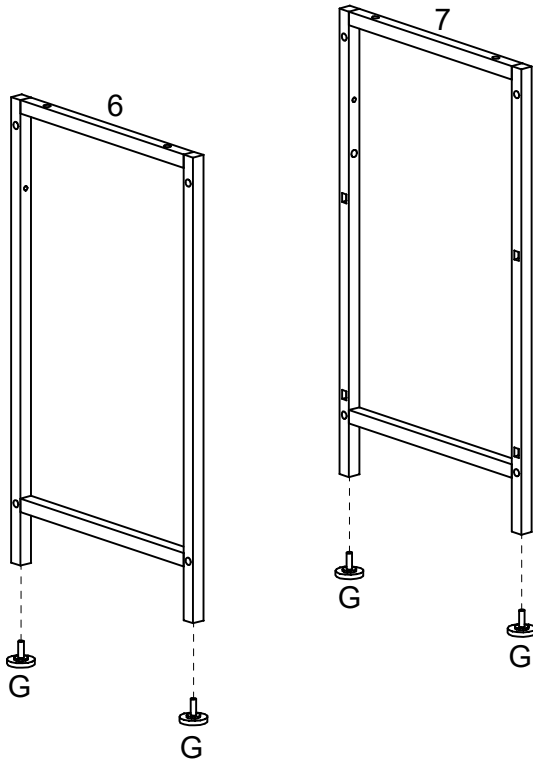

G	M6	X4
---	----	----

2

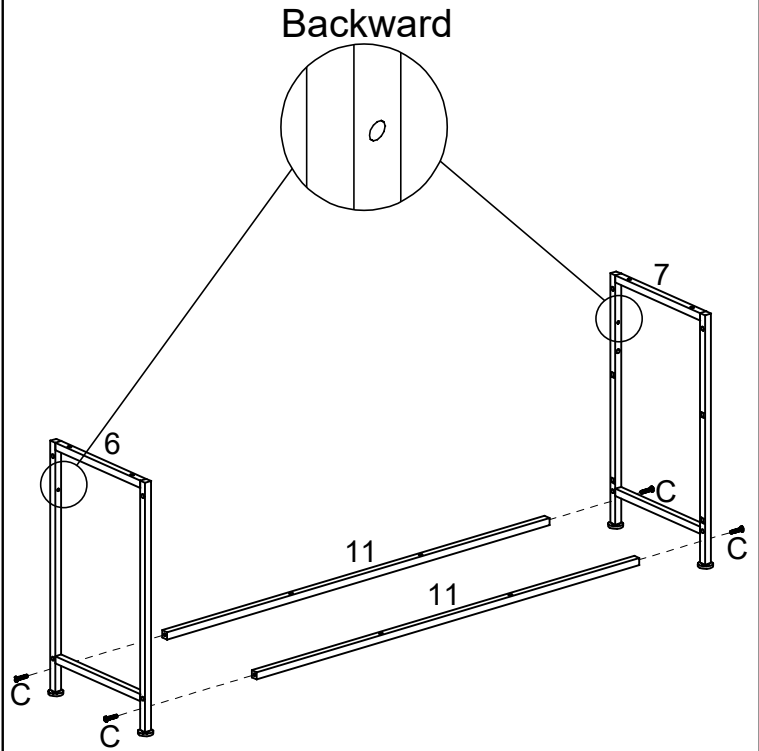

C	M6X23	X4
---	-------	----

3

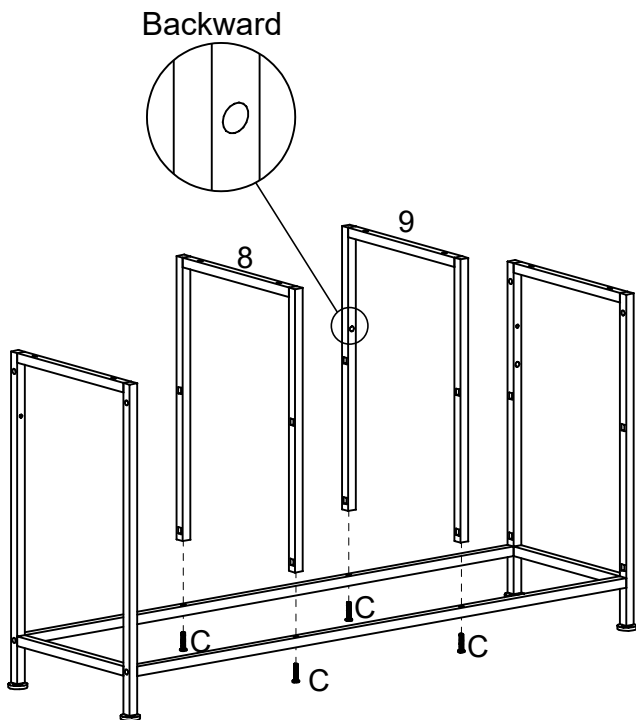

C	M6X23	X4
---	-------	----

4

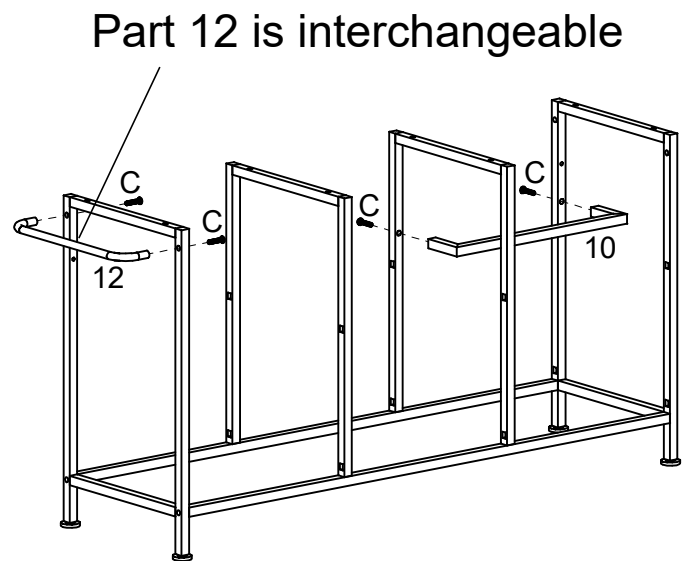

C	M6X23	X4
---	-------	----

5

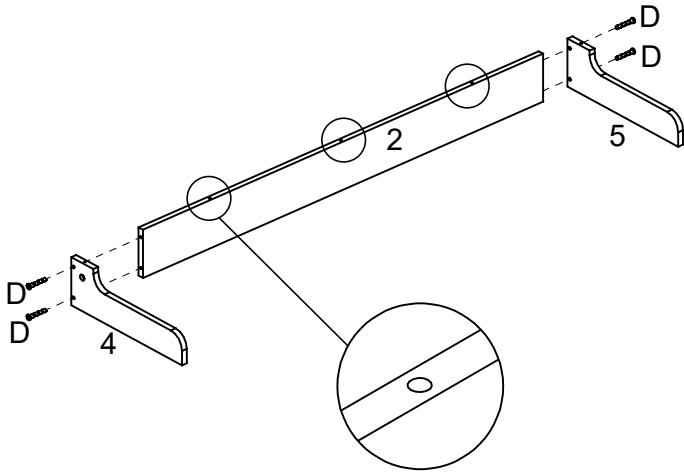

Big holes facing up

D	M5X40	X4
---	-------	----

6

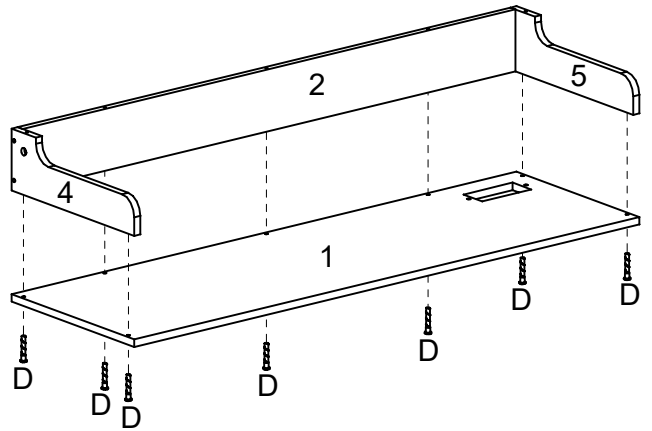

D	M5X40	X7
---	-------	----

7

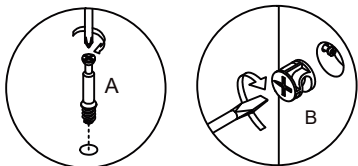
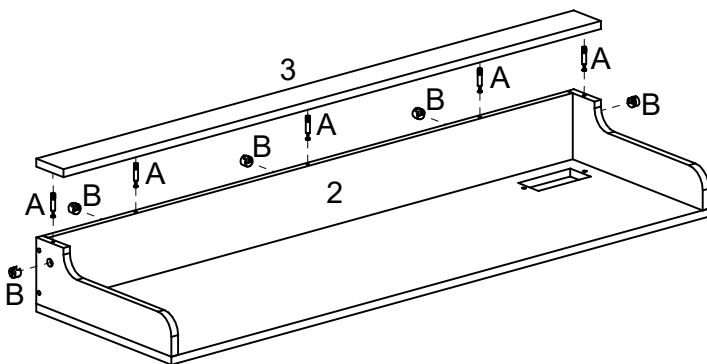

When part B is put into the hole,  
the notch above it is first aligned with part A,  
and then clockwise tighten part B.

A		X5
B		X5

8

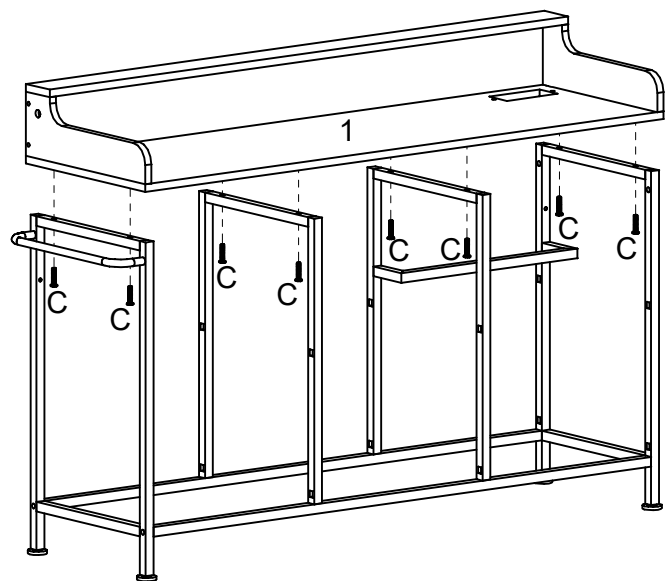

C	M6X23	X8
---	-------	----

9

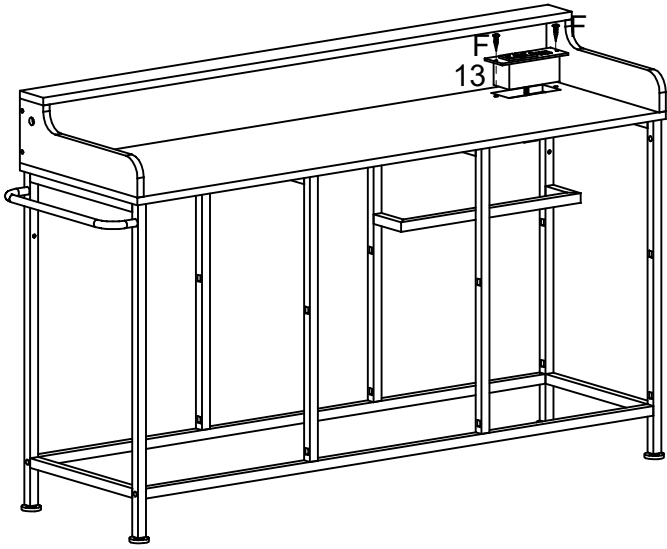

F	M4X12	X2
---	-------	----

10

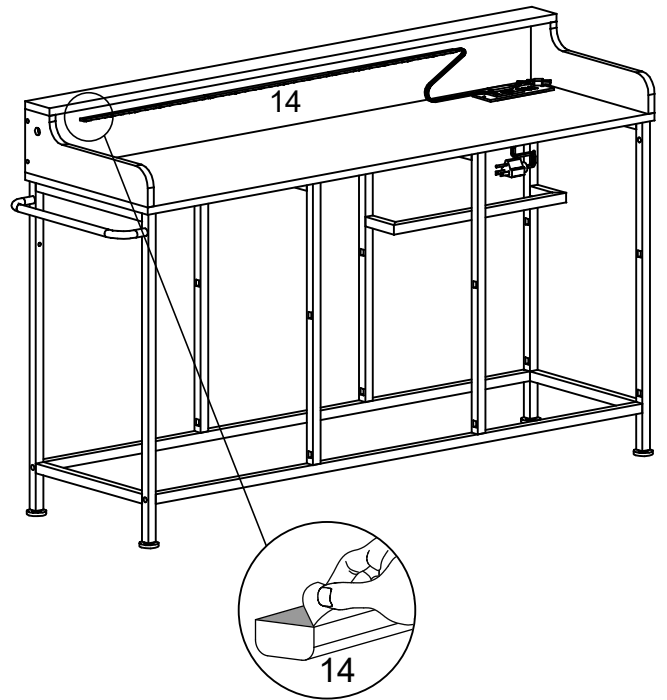

Rip the protective paper

11

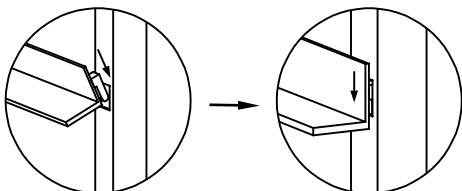
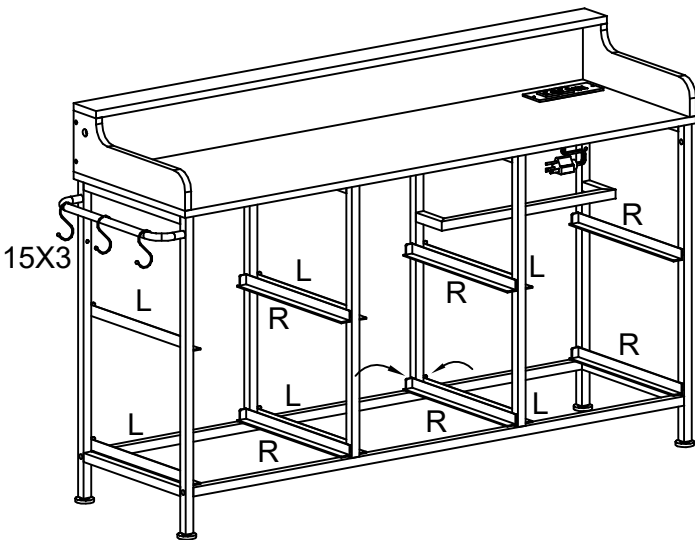

L		X6
R		X6

12

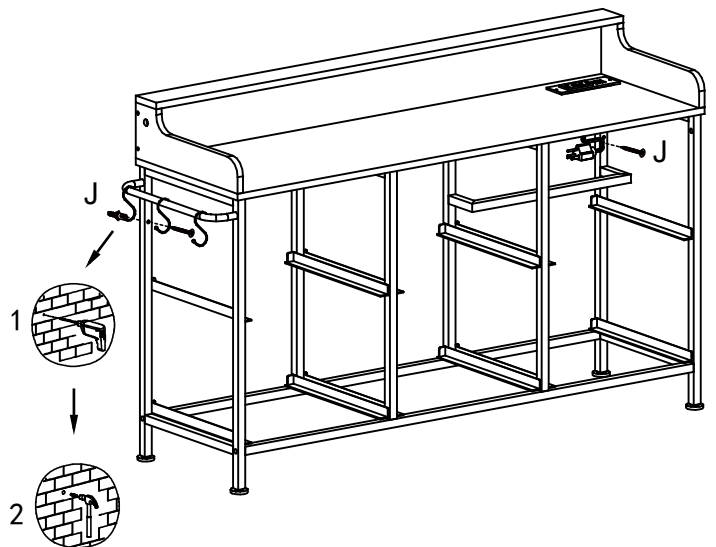

J		X1
---	--	----

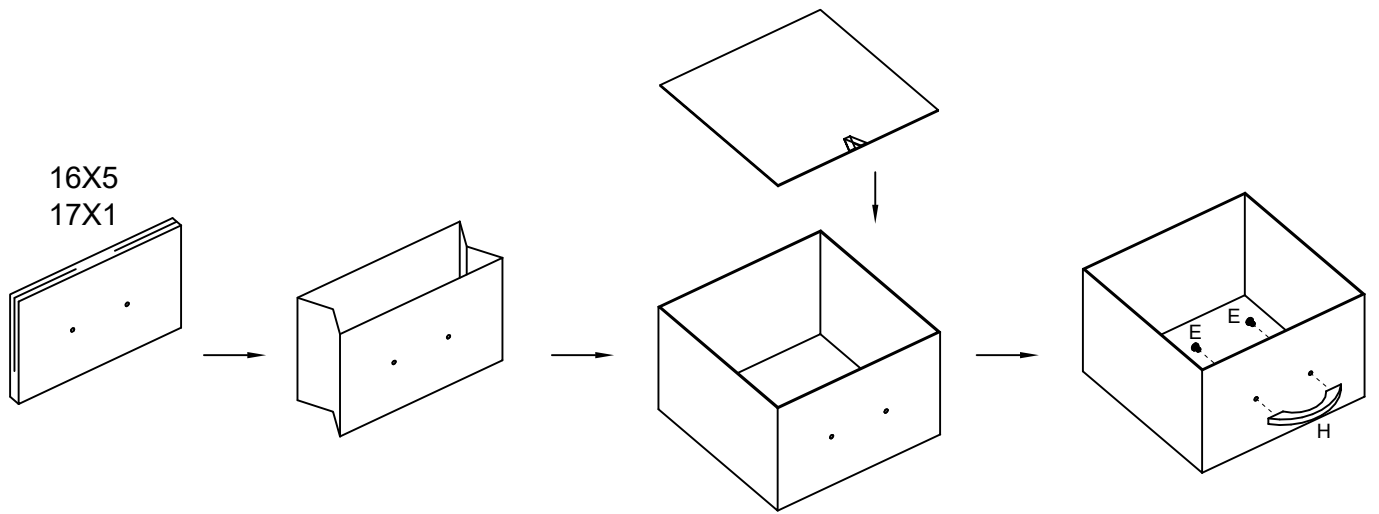

E	M4X10	X12
H		X6

