













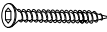

ASSEMBLY INSTRUCTIONS

Before you begin, please follow assembly instructions carefully, then follow them step by step.

Read instruction carefully . See Furniture Parts list and Hardware List for guidance . Be sure you have all parts before you start assembling . Place and assemble furniture on a clean flat soft surface , such as carpet or rug to prevent being scratched .

PART LIST		QTY
1	TOP PANEL	1 PC
2	BOTTOM PANEL	1 PC
3	SIDE PANEL (L)	1 PC
4	SIDE PANEL (R)	1 PC
5	CENTER PANEL (L)	1 PC
6	CENTER PANEL (R)	1 PC
7	BACK PANEL	1 PCS
8	DRAWER FRONT	2 PCS
9	DRAWER BACK	2 PCS
10	DRAWER SIDE	4 PCS
11	BOTTOM DRAWER	2 PCS
12	MIDDLE BONE	4 PCS
13	CENTER LEG	1 PCS
14	APRON BONE FRONT	1 PCS
15	APRON BONE BACK	1 PCS
16	APRON BONE SIDE	2 PCS

HARDWARE			
A	MINI FIX	A1  A2  A3 	12 SETS
B	M8 X 30MM WOOD DOWEL		20 PCS
C	M6 X 50MM CSK CAP WOOD SCREW		8 PCS
D	ALLEN KEY M4		1 PC
E	M3.5 X 16MM C.B SCREW		24 PCS
F	M4 X 30MM C.B SCREW		2 PCS
G	M4 X 38MM C.B SCREW		30 PCS
H	5/8 NAIL		48 PCS
I	JCBC Screw M6 x 25MM		8 PCS
J	5/8 PVC NAIL LEG		5 PCS
K	14" DRAWER SLIDE	K1 (L/R)  K2 (L/R) 	2 SETS

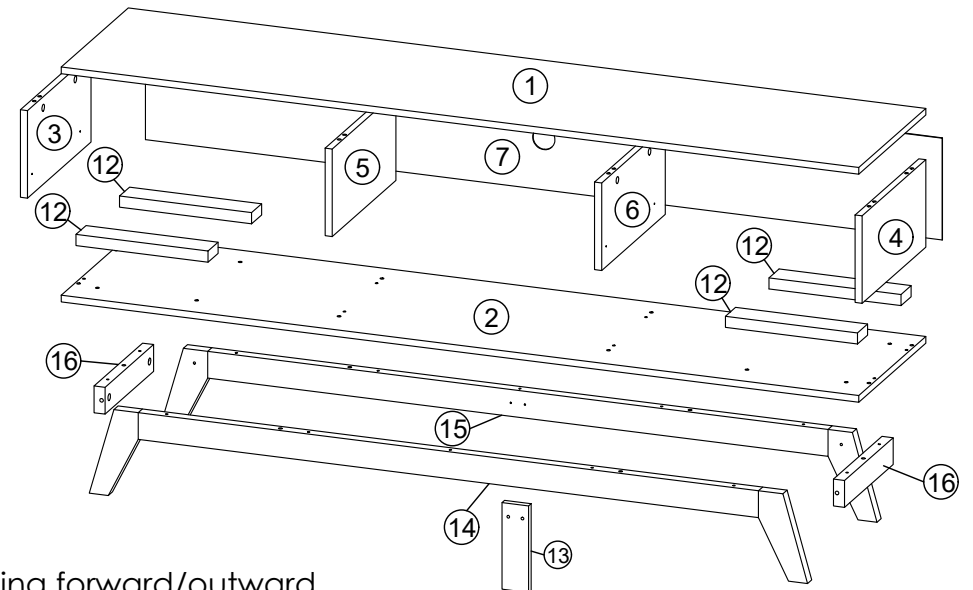
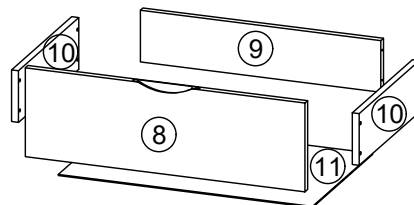
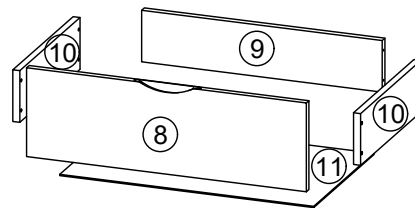
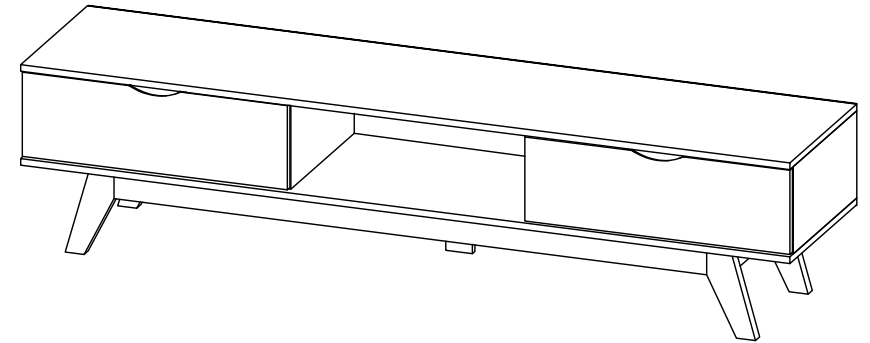

SELF-PREPARED TOOLS: Tools below are NOT included in package.



SCREWDRIVER



HAMMER

Reminder:

Please ensure that all surfaces and edges with colours/laminations are facing forward/outward.

ASSEMBLY INSTRUCTIONS

STEP 1

- Insert hardware **A1** onto panel **(3),(4),(5)** and **(6)**.
(Repeat 8 times.)
- Insert hardware **A2** onto panel **(1)**.
(Repeat 8 times.)
- Insert hardware **B** onto panel **(3),(4),(5)** and **(6)**.
(Repeat 16 times.)

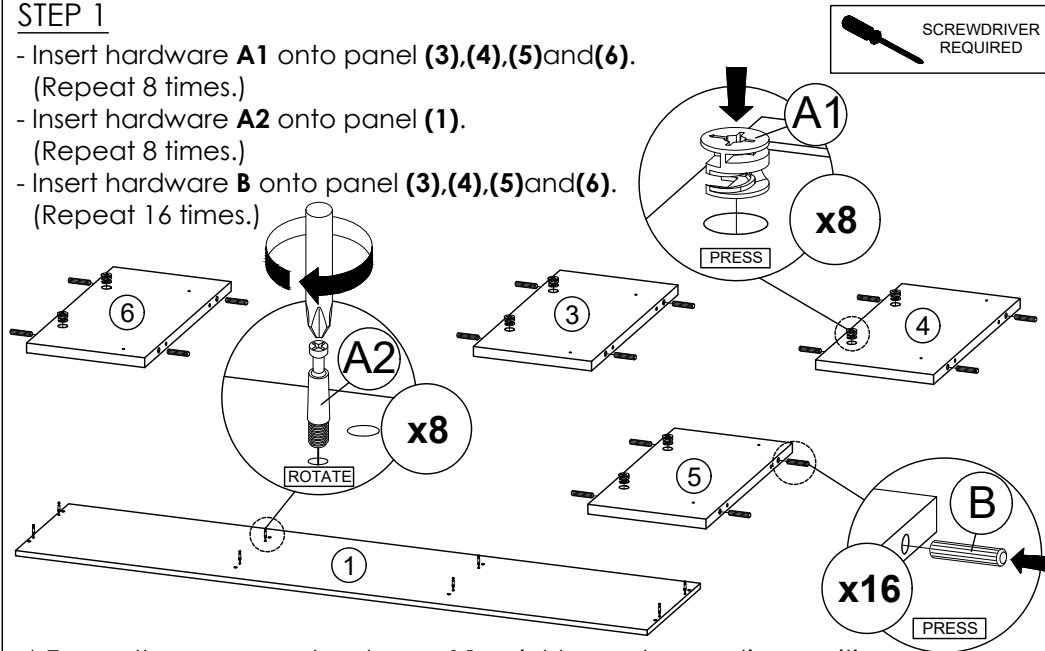

* Ensure the arrows on hardware **A1** point towards mounting positions.

STEP 2

- Insert hardware **A1** onto panel **(15)**.
(Repeat 4 times.)
- Insert hardware **A2** onto panel **(14)**.
(Repeat 4 times.)
- Insert hardware **B** onto panel **(14)** and **(15)**.
(Repeat 4 times.)

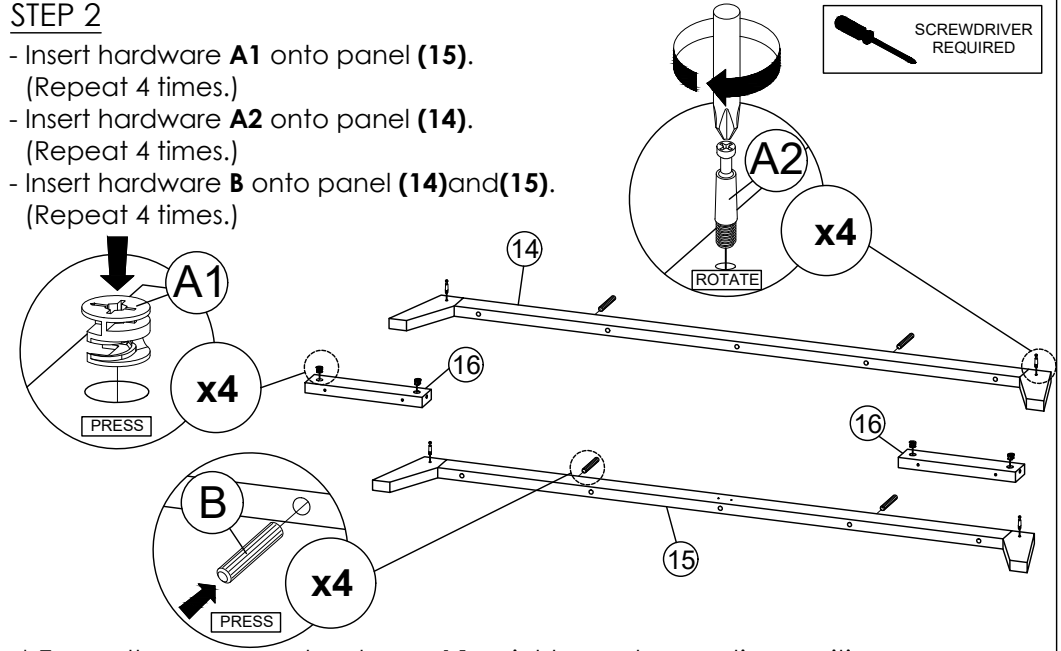

* Ensure the arrows on hardware **A1** point towards mounting positions.

STEP 3

- Fix hardware **K1 (L)** into panel **(3)** and **(6)** with hardware **E**.
- Fix hardware **K1 (R)** into panel **(4)** and **(5)** with hardware **E**.
- (Repeat 3 times for each hardware.)

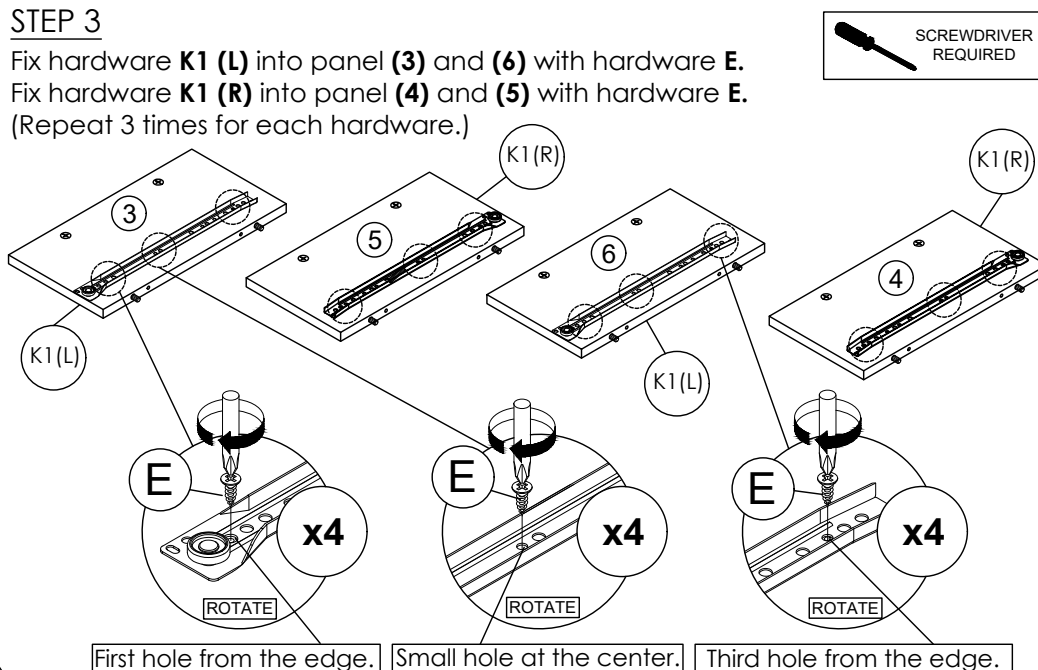

First hole from the edge. Small hole at the center. Third hole from the edge.

STEP 4

- Attach panel **(3),(4),(5)** and **(6)** to panel **(1)**.
- Insert all hardware **A2** into **A1**.
- Rotate all **A1** until tight.
- Apply **A3** onto all **A1**.
(Repeat 8 times.)

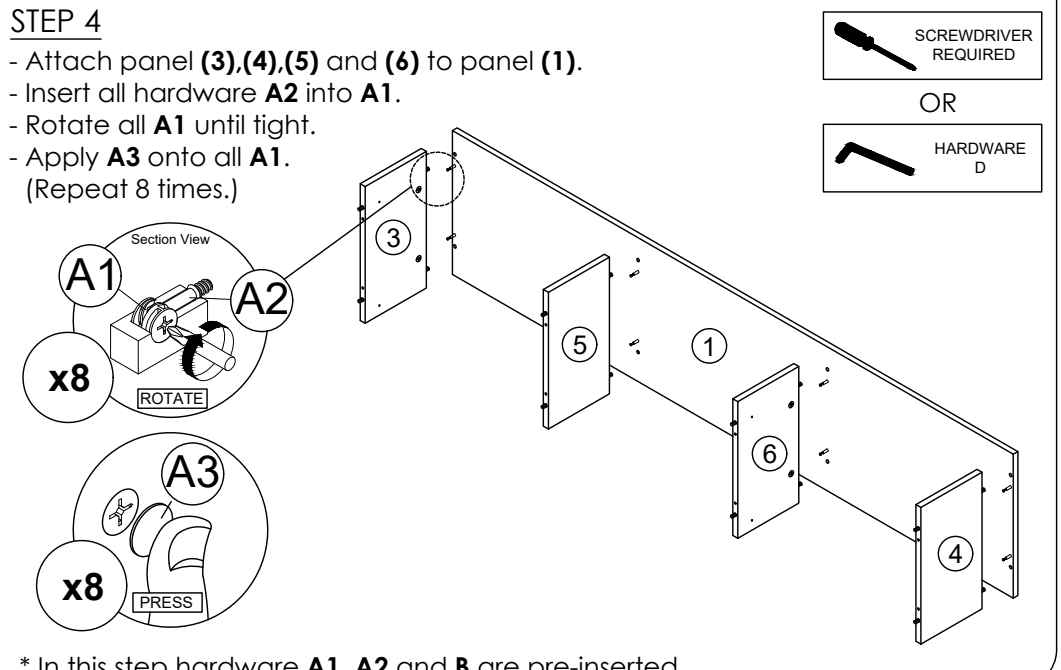

* In this step hardware **A1**, **A2** and **B** are pre-inserted.

ASSEMBLY INSTRUCTIONS

STEP 5

- Attach panel (14) to panel (15).
- Insert all hardware A2 into A1.
- Rotate all A1 until tight.
- Apply A3 onto all A1.
- (Repeat 4 times.)

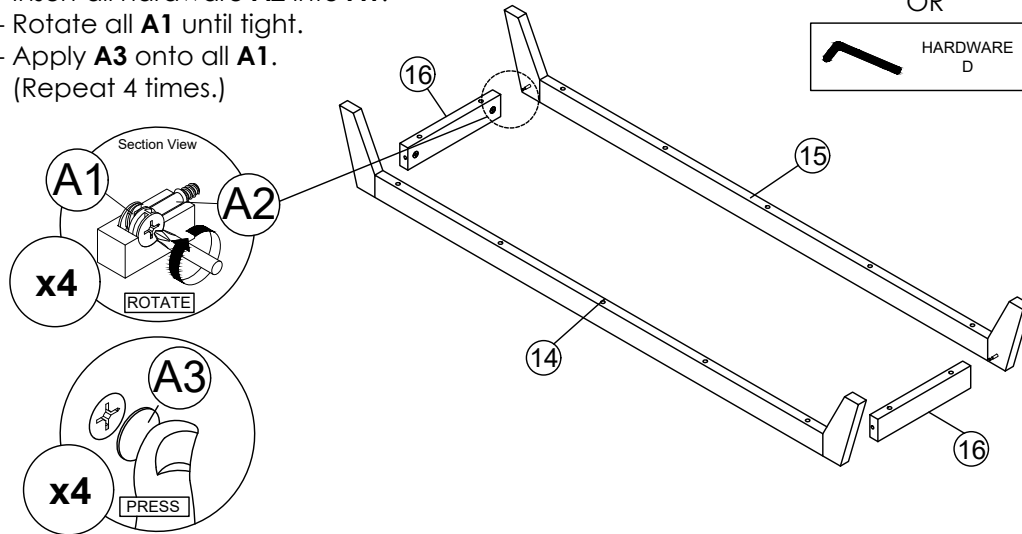
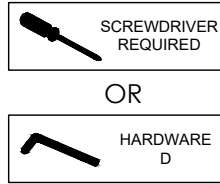

* In this step hardware A1, A2 and B are pre-inserted.

STEP 6

- Connect panel (14) and (15) to panel (2) by using hardware G.
- (Repeat 14 times.)

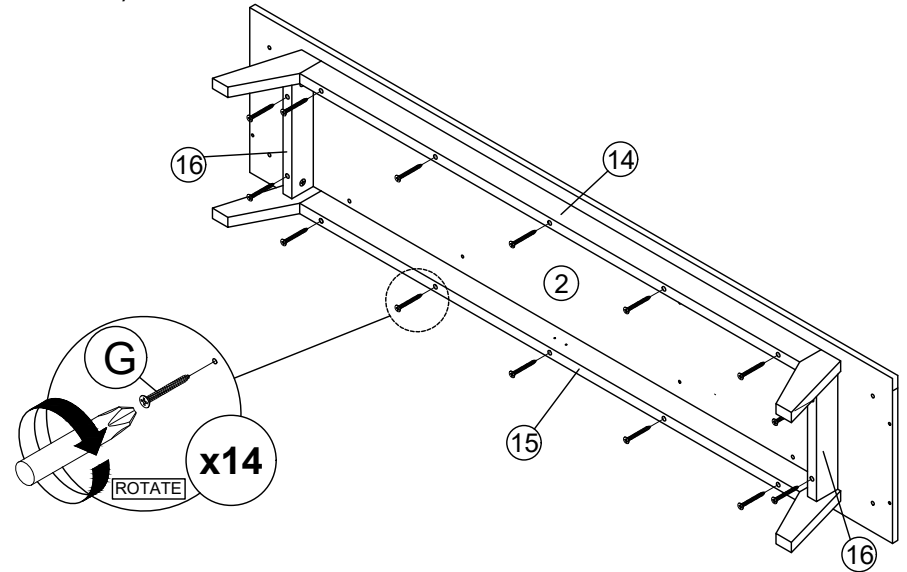

STEP 7

- Connect panel (12) to panel (2) by using hardware D and I.
- (Repeat 8 times.)
- Hit hardware J at the bottom of panel (14) and (15).
- (Repeat 4 times.)

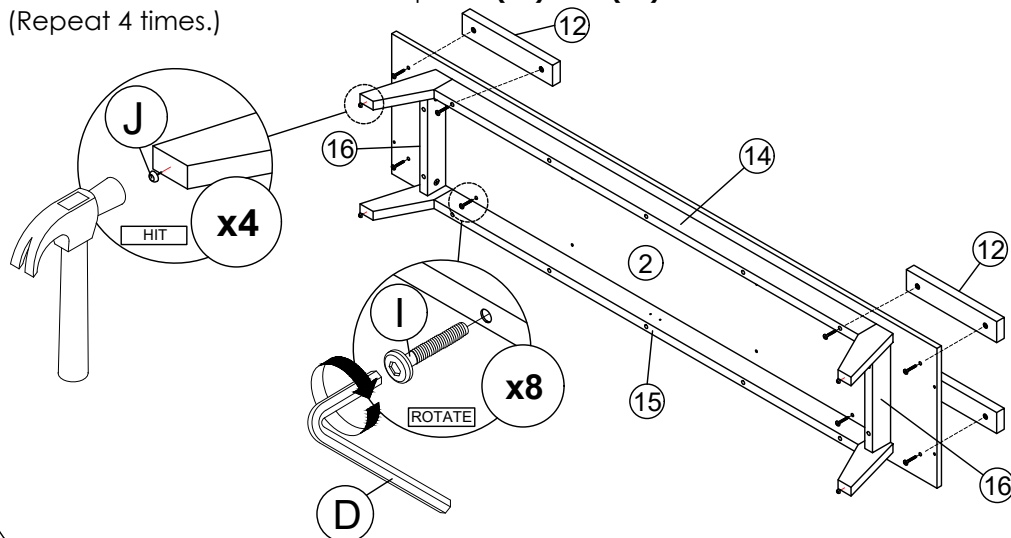

STEP 8

- Connect panel (2) to panel (3),(4),(5) and (6) by using hardware C and D.
- (Repeat 8 times.)

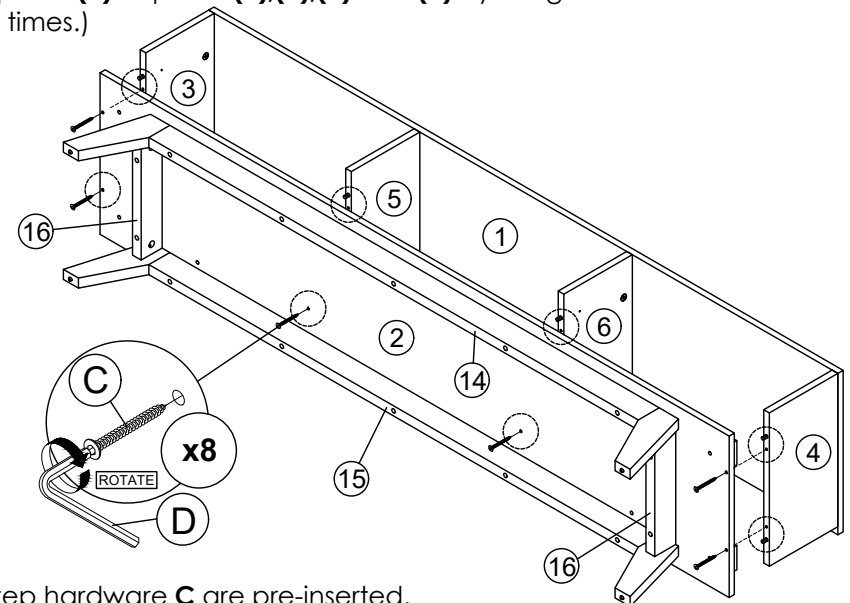

* In this step hardware C are pre-inserted.

ASSEMBLY INSTRUCTIONS

STEP 9

Assemble panel (7) to entire body with hardware H.
(Repeat 24 times.)

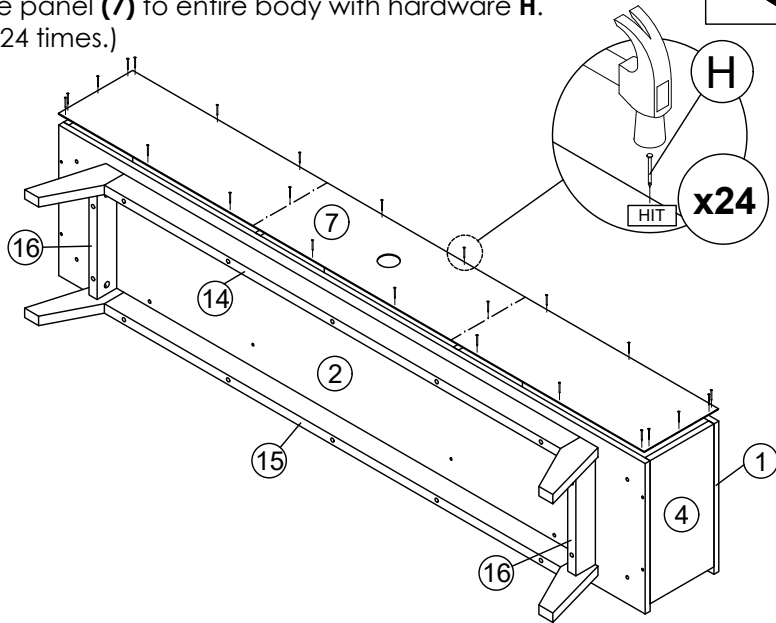

STEP 10

- Fix hardware F onto panel (15) by using screwdriver.
(Repeat 2 times)
- Hit hardware J at the bottom of panel (13).
(Repeat 1 times.)

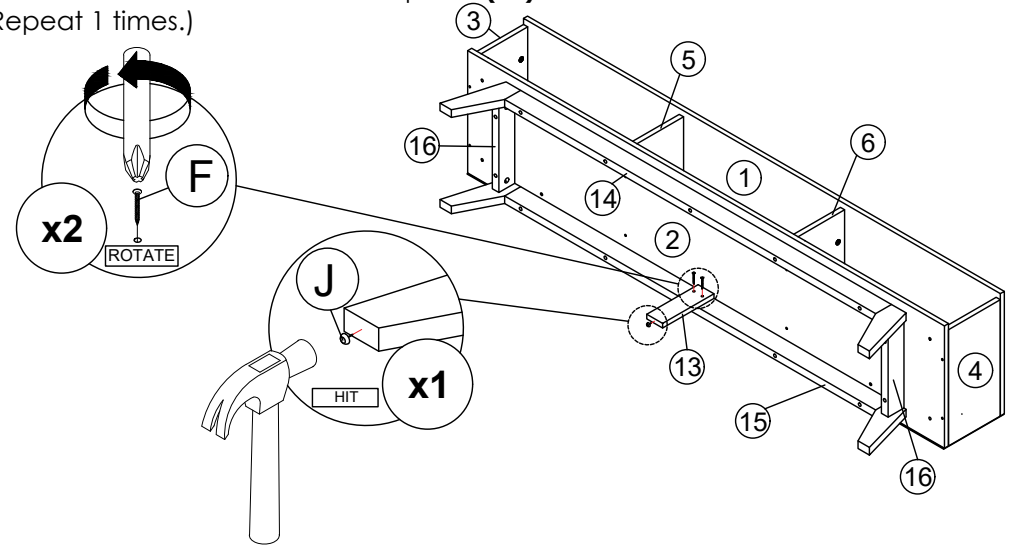

STEP 11

Assemble panel (10) to panel (8) and (9)
by using hardware G.
(Repeat 8 times.)



* In this step only show one of the drawers.

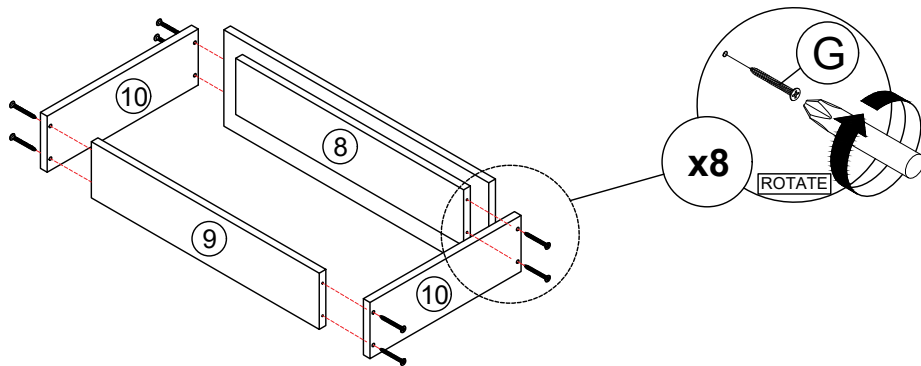

STEP 12

Assemble panel (11) to entire body with hardware H
(Repeat 12 times.)



* In this step only show one of the drawers.

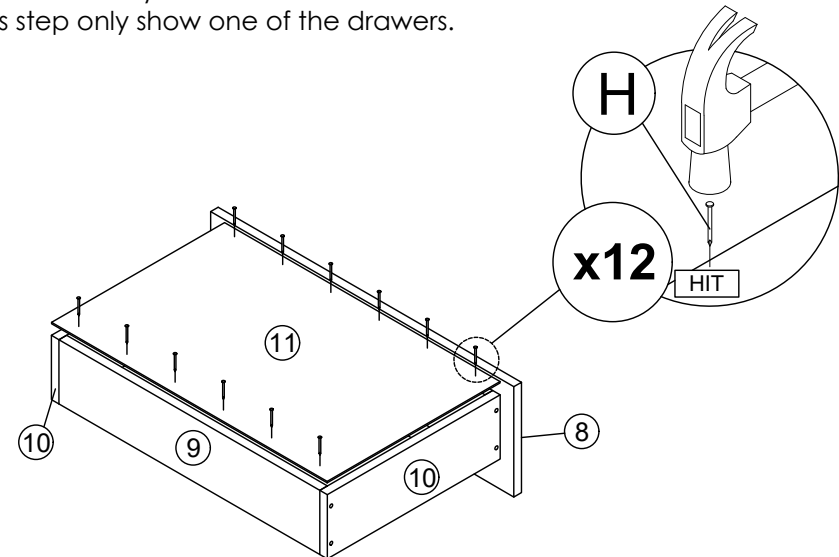

ASSEMBLY INSTRUCTIONS

STEP 13

Assemble hardware **K2 (L) & K2(R)** to panel **(11)** by using hardware **E**.

(Repeat 6 times for each hardware.)

* In this step only show one of the drawers.

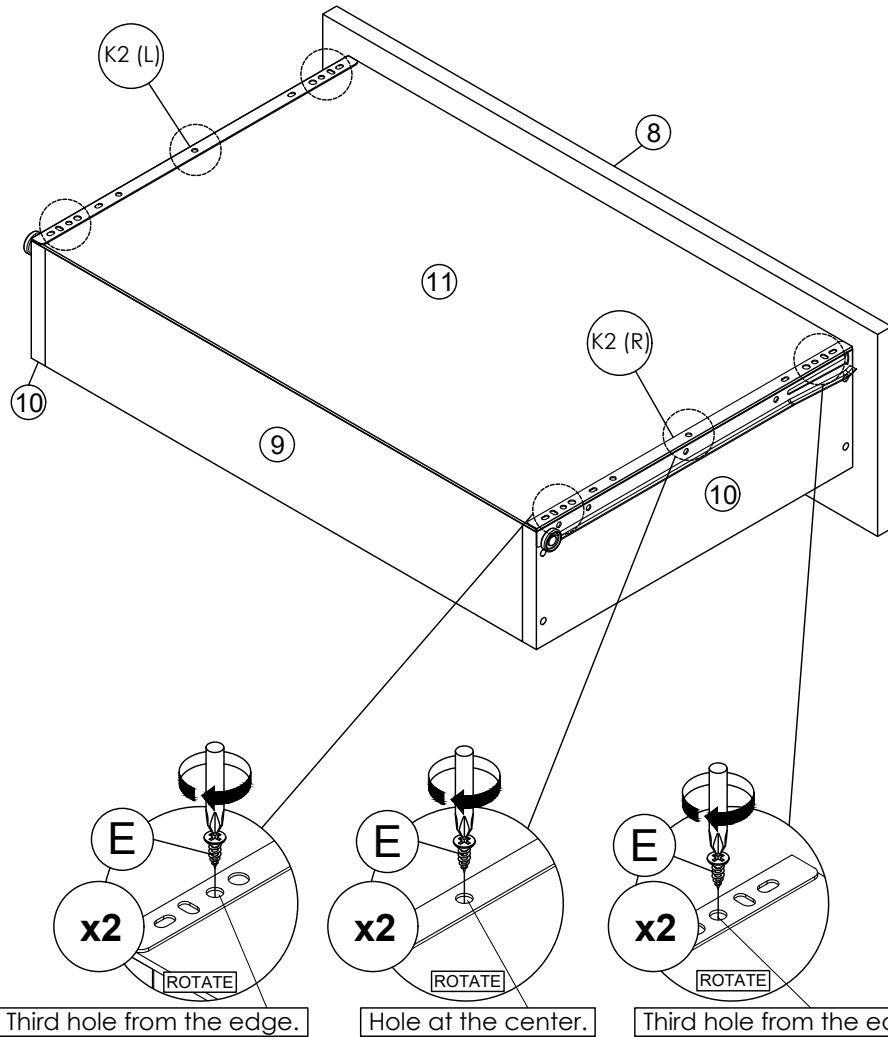

*Hardware **K2 (L),K2 (R)** shall be leaning against panel **(8)** when assembling.

STEP 14

Put all the drawer in place along the drawer slides.

