

INSTRUCTIONS  
 ANWEISUNG  
 取扱説明書  
 INSTRUCTION  
 사용설명서  
 LIBRO DE INSTRUCCIONES  
 LSTRUZIONI PER L'INSTALLAZIONE



\*Two people for assembly  
 \*Installieren zwei Personen zusammen  
 \*2人作業が必要です  
 \*Deux personnes pour l'assemblage  
 \*조립을 위해 두 사람 필요  
 \*Due persone per il montaggio  
 \*Dos personas para el montaje

**⚠ WARNING**



**Children have died from furniture tipover.**

- NEVER allow children to stand, climb or hang on drawers, doors, or shelves.
- ALWAYS secure your television with an anchor device.

This is a permanent label. Do not remove!

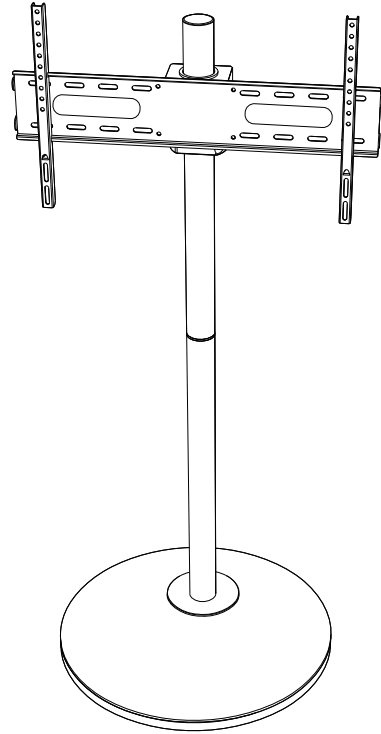

A\*1

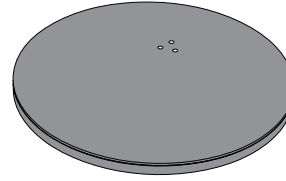

B\*1

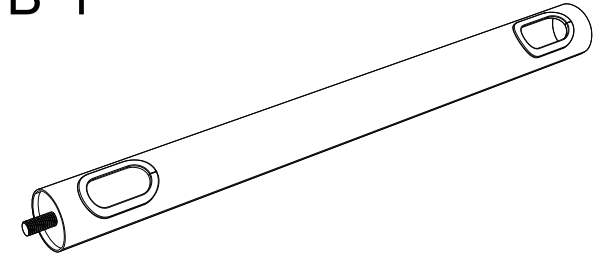

C\*1

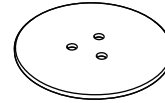

D\*1

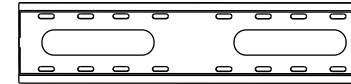

E\*1

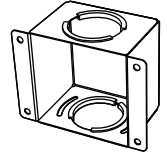

F\*1

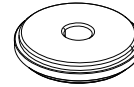

G\*1

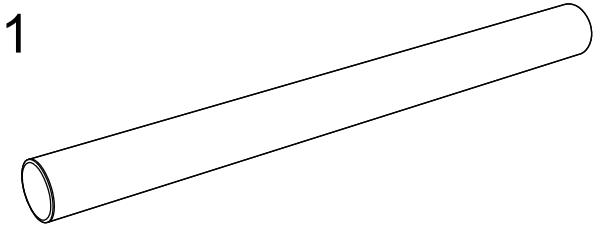

H\*1

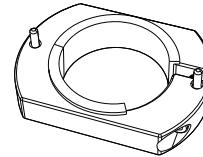

I\*2

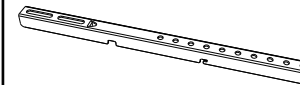

J\*1



Y\*1



K\*4



L\*4



M\*3

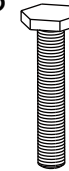

N\*3



O\*1



4mm

P\*4

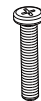

M6\*25mm

Q\*4



M8\*25mm

R\*4



S\*4



T\*1



5mm

①

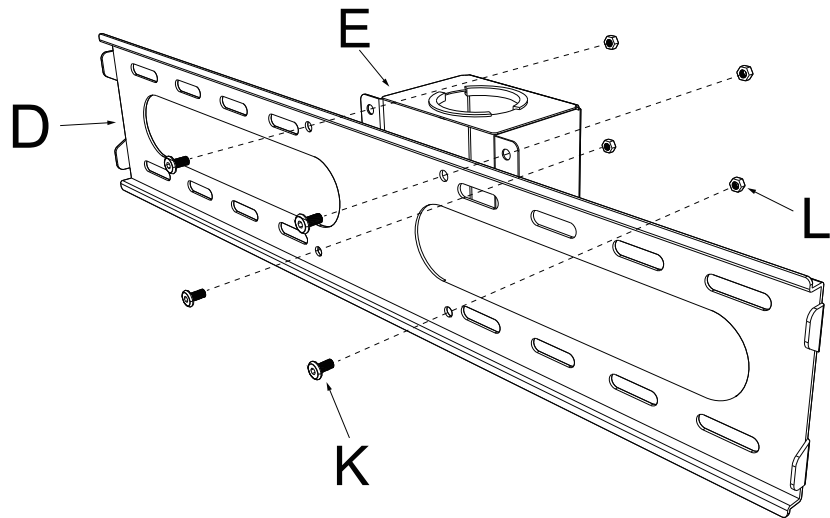
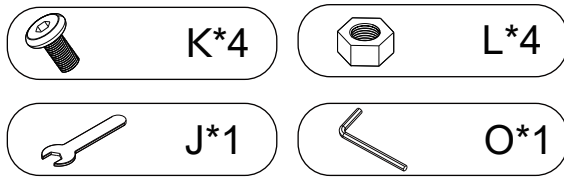

②

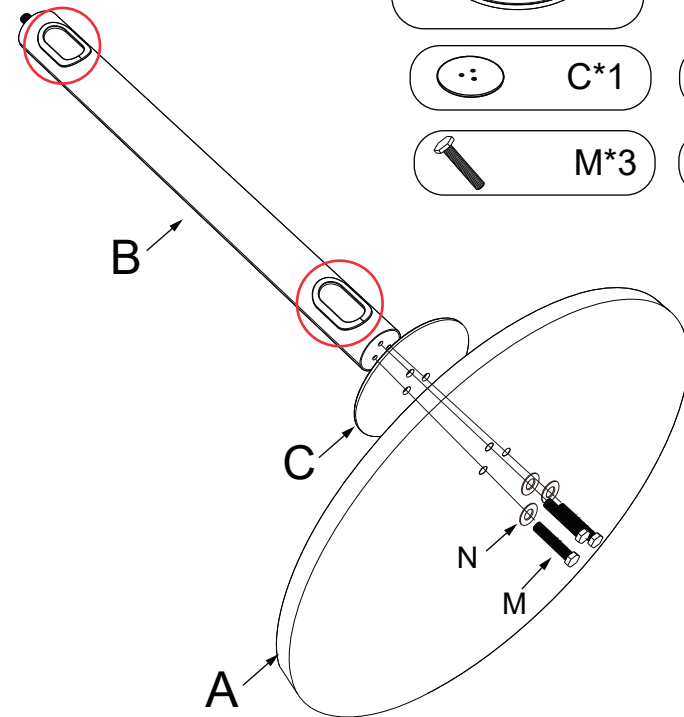
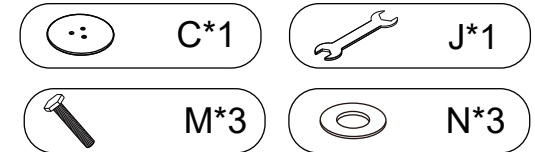
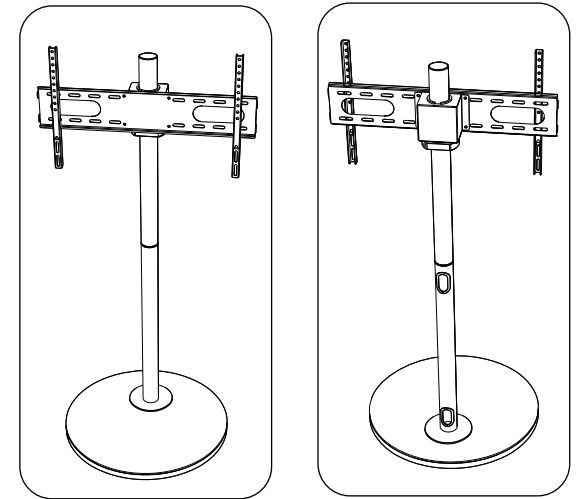

Please pay attention to the position of cable outlet when screw, as the outlet is at the back side.

Hinweis: Die Kabelöffnung befindet sich auf der Rückseite. Achten Sie beim Anziehen der Schrauben auf die Position der Kabelöffnung.

注意: 支柱を取付けるとき、配線孔が背面に向いていることを確保してください。

Veillez faire attention à la position de la sortie du câble lors du vissage, car elle se trouve à l'arrière.

출사구가 등뒤에 있으니 나사조임시 출사구의 위치를 주의하십시오.

La salida de cables está en la parte trasera; al apretar los tornillos, tenga en cuenta la posición de la salida de cables.

L'uscita del cavo è sul retro. Prestare attenzione alla posizione dell'uscita del cavo quando si stringono le viti.

3

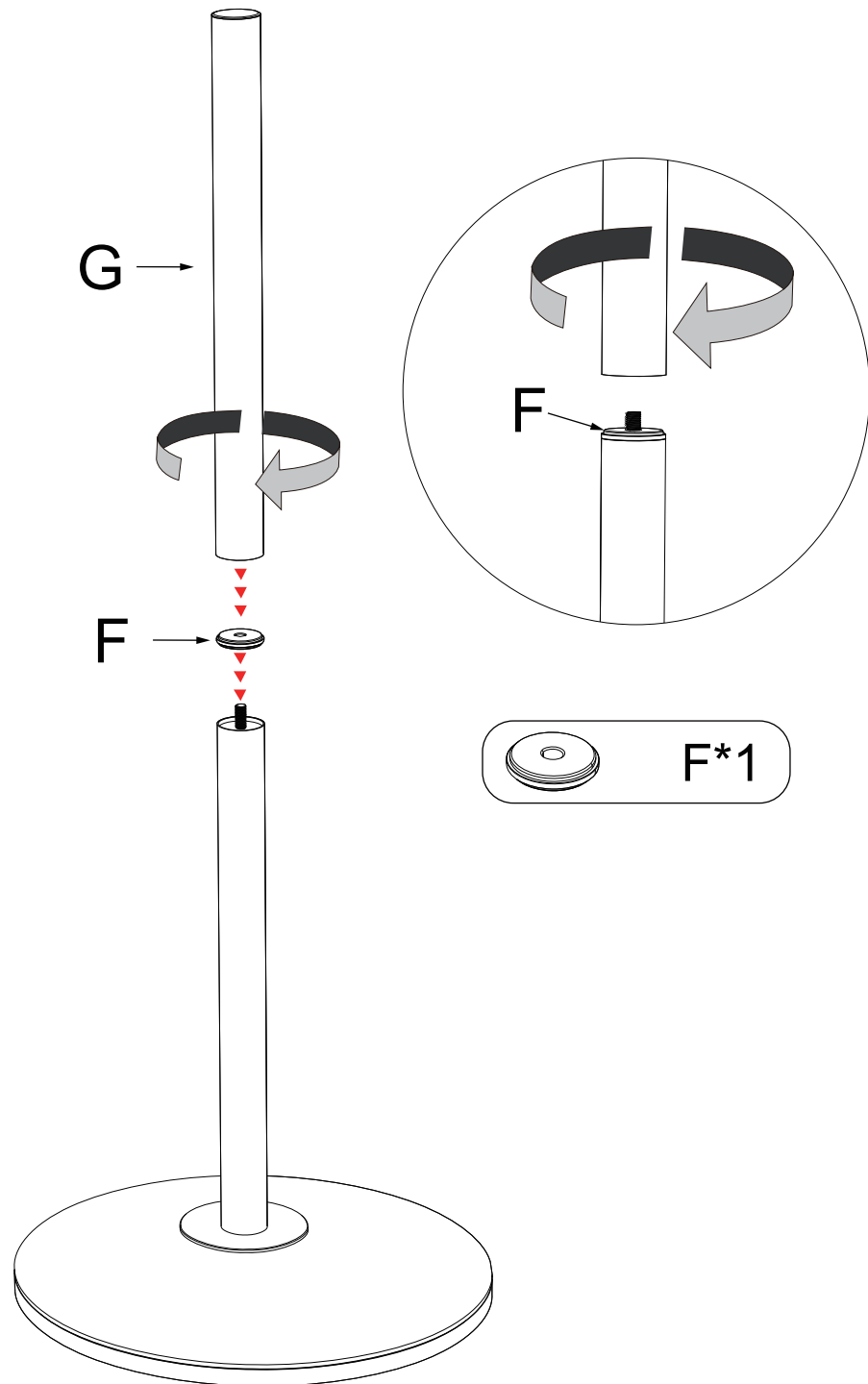

4

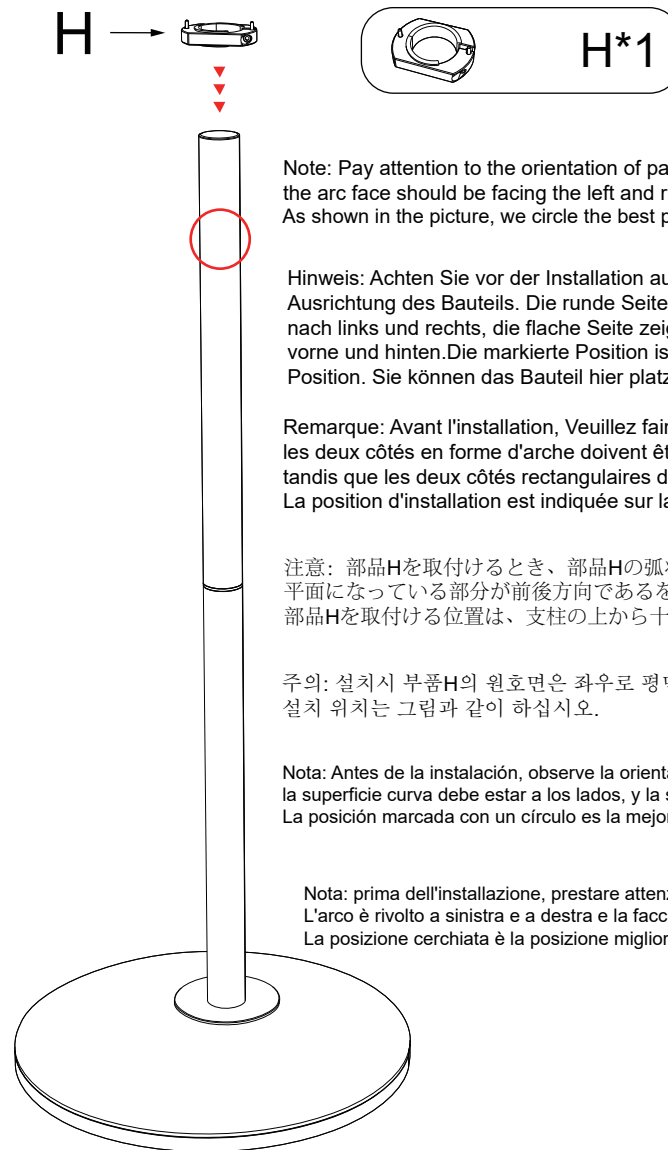

Note: Pay attention to the orientation of part H before installation, the arc face should be facing the left and right, while the flat is front and back. As shown in the picture, we circle the best position where you can place the part H nicely.

Hinweis: Achten Sie vor der Installation auf die Ausrichtung des Bauteils. Die runde Seite zeigt nach links und rechts, die flache Seite zeigt nach vorne und hinten. Die markierte Position ist die optimale Position. Sie können das Bauteil hier platzieren.

Remarque: Avant l'installation, Veuillez faire attention à l'orientation de la pièce H, les deux côtés en forme d'arc doivent être dirigés vers la gauche et la droite, tandis que les deux côtés rectangulaires doivent être orientés vers l'avant et l'arrière. La position d'installation est indiquée sur la figure.

注意: 部品Hを取付けるとき、部品Hの弧状になっている部分が左右方向で、平面になっている部分が前後方向であることを確保してください。部品Hを取付ける位置は、支柱の上から十分の一ぐらいのところがおすすめです。

주의: 설치시 부품H의 원호면은 좌우로 평면은 전후로 향하게 주의하십시오. 설치 위치는 그림과 같이 하십시오.

Nota: Antes de la instalación, observe la orientación de los accesorios; la superficie curva debe estar a los lados, y la superficie plana hacia adelante y hacia atrás. La posición marcada con un círculo es la mejor ubicación; coloque los accesorios aquí.

Nota: prima dell'installazione, prestare attenzione all'orientamento degli accessori. L'arco è rivolto a sinistra e a destra e la faccia piatta è rivolta in avanti e indietro. La posizione cerchiata è la posizione migliore in cui è possibile posizionare gli accessori.

5

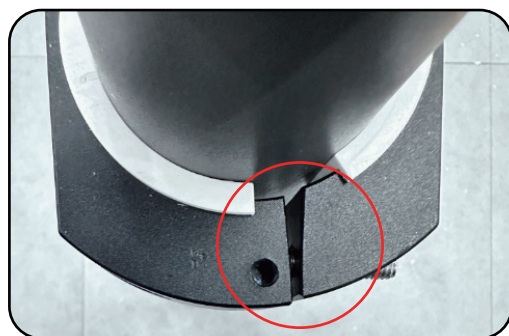
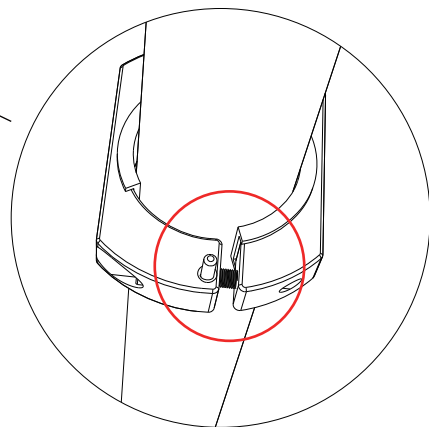
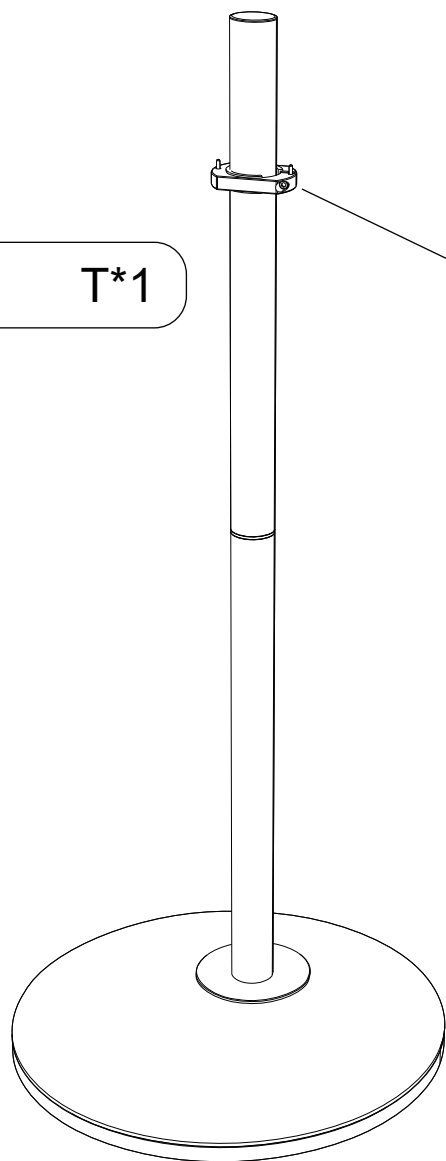
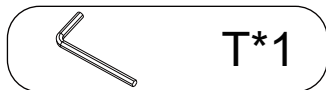

Tighten the screws with a hex wrench. Note: The screws need to be tightened until they can no longer be tightened. It's normal phenomenon that aluminum alloy deforms.

Verwenden Sie den Inbusschlüssel, um die Schrauben festzuziehen.  
Hinweis: Ziehen Sie die Schrauben fest an, bis sie sich nicht mehr bewegen lassen! Aluminiumlegierung kann sich verformen, aber keine Sorge mehr.

六角スパナでネジをしっかりと締めてください（部品がちょっと変形しても大丈夫です）。

Serrer fermement les vis à l'aide d'une clé hexagonale.  
L'aluminium peut se déformer, mais ne vous inquiétez pas.

육각렌치를 사용해 끝까지 조이시고 알루미늄 합금이 변형될 수 있어도 걱정하지 마십시오.

Use una llave hexagonal para apretar; tenga en cuenta: los tornillos deben apretarse hasta que no se puedan mover más.  
El aluminio puede deformarse, pero no se preocupe.

Utilizzare una chiave esagonale per serrare. Nota: la vite deve essere serrata fino a quando non può essere serrata! La lega di alluminio verrà deformata, per favore non preoccuparti

⑥

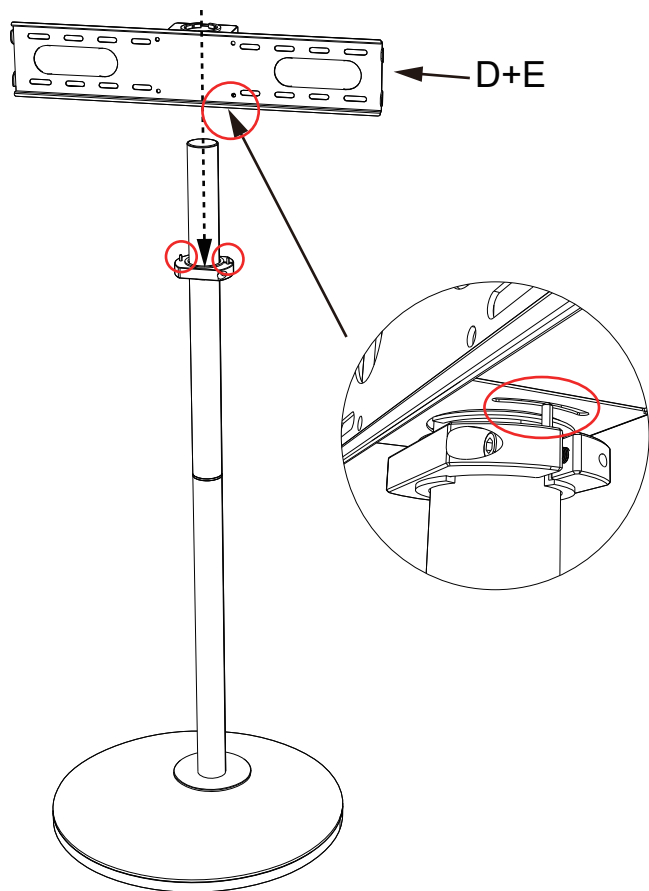

Pay attention to the front and back.  
The groove on the bottom must face downwards

Achten Sie auf die Vorder- und Rückseite.  
Die Nut an der Unterseite muss nach unten zeigen.

弧状の隙間が空いている片面が下  
に向いていることを確保してください。

Attention à bien distinguer l'avant et l'arrière,  
la face avec une rainure est dirigée vers le bas.

앞뒷면의 방향에 주의하시고 홈이 있는 것은 아래로 향하게 하십시오.

Preste atención al anverso y al reverso; el lado con la ranura debe estar hacia abajo.

Prestare attenzione ai lati anteriore e posteriore.  
Quello con la tacca in basso è rivolto verso il basso.

⑦

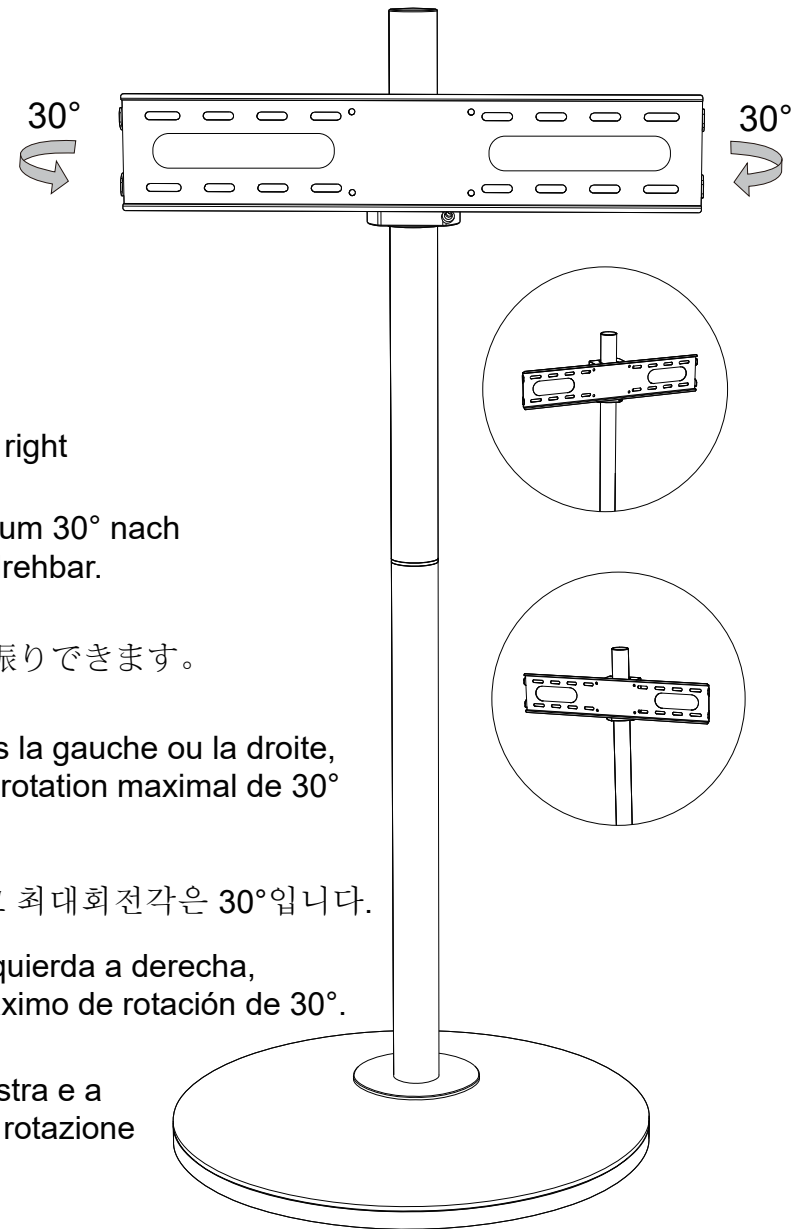

Swivel 30° left or right

Die Halterung ist um 30° nach  
links und rechts drehbar.

左右30°以内に首振りできます。

Il peut pivoter vers la gauche ou la droite,  
avec un angle de rotation maximal de 30°

좌우회전 가능하고 최대회전각은 30°입니다.

Puede girar de izquierda a derecha,  
con un ángulo máximo de rotación de 30°.

Può ruotare a sinistra e a  
destra, l'angolo di rotazione  
massimo è di 30°

8

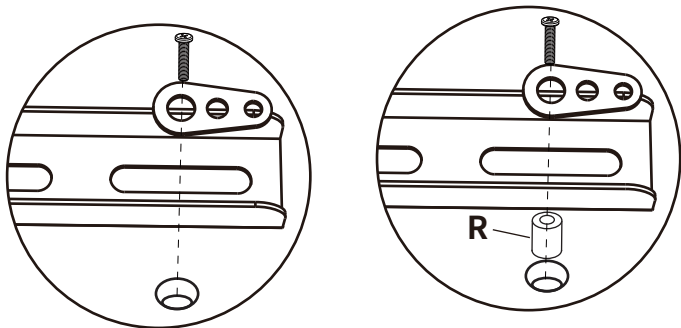
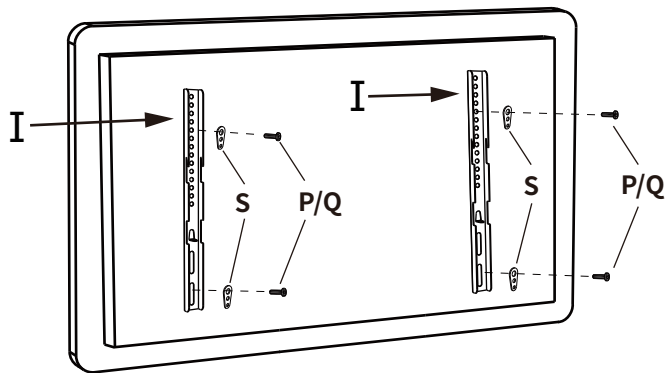
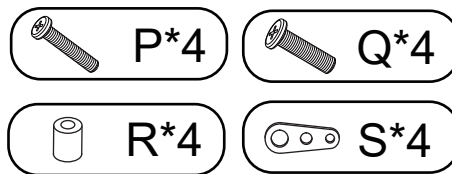

Attention: If the vesa pattern holes at back of the TV are unable to be connected with the hanger hooks firmly and level, Put part "R" between the TV and hanger hooks, and fix them firmly

Wenn die Schraubenlöcher auf der Rückseite des Fernsehers nicht auf derselben Ebene liegen, verwenden Sie das R-Zubehör.

Hinweis: Zubehör R muss zwischen dem Fernseher und dem Verbindungshaken platziert werden. Zur Befestigung können Sie zwischen P- und Q-Schrauben wählen.

もし、テレビの背面のネジ穴は同一平面上にない場合なら、パーツRをご利用ください。それに、ネジPまたはネジQをご使用ください。

Si les trous de vis à l'arrière du téléviseur ne sont pas sur le même plan, utilisez la pièce R. Sinon, utilisez la vis P ou la vis Q.

만약에 베사 나사 구멍은 동일한 평면에 있지 않은 다면 부품 R를 이용하십시오. 나사 P 또는 나사 Q를 이용하십시오.

Si necessita usar la arandela gruesa R, debe colocarse entre el televisor y el gancho de conexión.

Se è necessario utilizzare una rondella più spessa R, la rondella R deve essere inserita tra la TV e il gancio di collegamento.

9

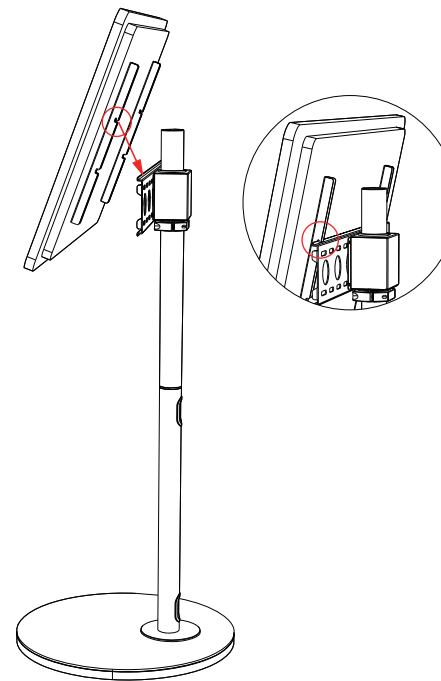

Recommended that two people lift the TV and tilt it slightly, hang the hook on the edge of the part C, then put down slowly, fix with 2 safety screws

Zwei Personen sind erforderlich, um den Fernseher schräg anzuheben und den Haken am oberen Teil von Zubehörteil C aufzuhängen. Nachdem Sie es aufgehängt haben, senken Sie es langsam ab und verriegeln Sie die beiden Sicherheitsschrauben, um ein Herunterfallen zu verhindern.

2人で、テレビをスタンドに掛けてください。最後、フックにあった落下防止する長ネジを締めます。

Nous recommandons que deux personnes soulèvent le téléviseur sur le support. Enfin, verrouillez les deux vis.

2명에서 TV를 스탠드에 걸어주세요. 마지막, 후크에 있던 낙하 방지하는 긴 나사를 조이십시오.

Dos personas deben levantar el televisor, inclinarlo ligeramente y colgar el gancho en la parte superior del panel D. Luego, bájelo suavemente y fíjelo con los dos tornillos de seguridad.

Le due persone sollevano la TV, la inclinano leggermente, appendono il gancio al bordo del pannello D, quindi la posano lentamente verso il basso, quindi bloccano le due viti di sicurezza per fissarla.

