

SERVING CART

ASSEMBLY INSTRUCTION



Assembly Instruction

ASSEMBLY TIPS:

1. Remove hardware from box and sort by size.
2. Please check to see that all hardware and parts are present prior start of assembly.
3. Please follow attached instruction in the same sequence as numbered to assure fast & easy assembly.









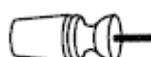

Warning!

1. Don't attempt to repair or modify parts that are broken or defective.
Please contact the store immediately.
2. This product is for home use only and not intended for commercial establishment.

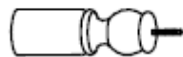
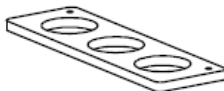
ASSEMBLY TIME PER UNIT : 30 MINUTES

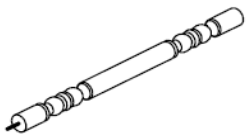
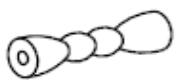
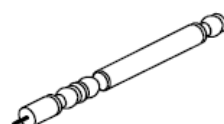



PARTS IDENTIFICATION

(A) TOP & BOTTON PANEL	2 PCS	(G) HANDLE	1 PC
			
(B) BRACES	4 PCS	(H) LEG	4 PCS
			
(C) FRONT CROSSBAND	2 PCS	(I) POST	2 PCS
			
(D) SHELF PANEL	1 PC	(J) LEFT & RIGHT	2 PCS
			
(E) LONG POST	2 PCS	(K) PLASTIC DECORATION	18 PCS
			
(F) SHORT POST	2 PCS	(L) CROWN MOULDING	2 PCS
			

ASSEMBLY INSTRUCTION

Z

HARDWARE PACKAGE

NO	DESCRIPTION	FIGURE	Q' TY
1	WASHER 1/4" x 19mm		2 PCS
2	BOLT 3/16" x 2"		18 PCS
3	CASTER φ 40mm		4 PCS
4	BOX WRENCH 60mm		1 PC

STEP 1

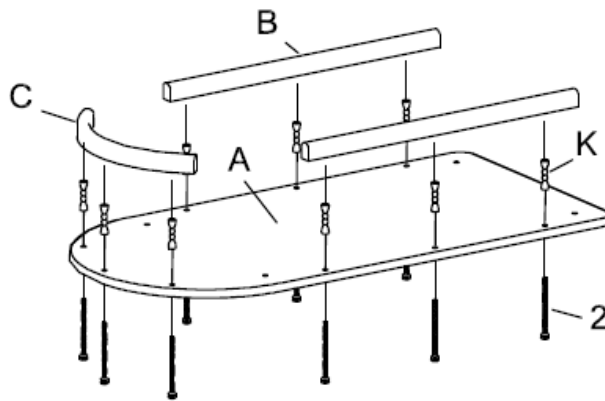

STEP 2

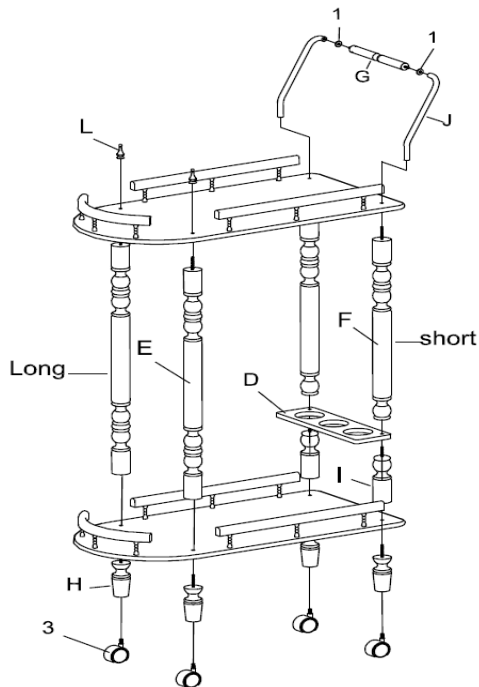

FINISH

