



ALWC15



32" x 14.75" x 23.63" (H x W x D)

15" wide built-in ADA compliant commercial wine cellar for display and refrigeration of up to 23 bottles, with glass door, digital controls, front lock, LED lighting, and black cabinet

Highlights:

32" height allows installation under lower ADA compliant counters

Flexible design allows built-in or freestanding use

Digital thermostat offers precise and convenient temperature control

Product Features:

15" Wide Wine Cellar	Designed for built-in or freestanding installation in slim-fitting ADA compliant spaces
ADA Compliant	Sized at 32" high for use under lower ADA compliant counters
Built-in capable	Make the best use of space by installing your appliance under the counter
Seamless stainless steel trimmed glass door	Provides a full display of your stored collection with a heat-safe double tempered design
Factory installed lock	Keyed lock for a secure interior, with two keys included
Digital thermostat	Electronic controls for precise temperature management, with indicator lights for red, white, and sparkling wines
Digital display	Temperature readout can be shown in Celsius or Fahrenheit
Recessed LED lighting	Gentle illumination with an on/off switch
Wooden shelves	Classic look holds up to 23 Bordeaux or Burgundy style bottles



ALWC15 Specifications:

Overview	
Nominal Height	32.0" (81 cm)
Height of Cabinet	32.0" (81 cm)
Nominal Width	15.0" (38 cm)
Width	14.75" (37 cm)
Nominal Depth	24.0" (61 cm)
Depth	23.63" (60 cm)
Depth with Handle	25.38" (64 cm)
Depth with door at 90°	38.25" (97 cm)
Capacity	2.2 cu.ft. (62 L)
Bottles	23 bottles
Defrost Type	Automatic
Door	Glass
Cabinet	Black
US Electrical Safety	ETL
Canadian Electrical Safety	ETL-C
Amps	1.0
Voltage/Frequency	115 V AC/60 Hz
Weight	65.0 lbs. (29 kg)
Parts & Labor Warranty	1 Year
Compressor Warranty	5 Years
UPC	761101056395
Wine Cellar	
Number of Zones	1
Door Swing	RHD
Reversible	Yes
Adjustable Shelves	Yes
Shelf Type	Wood
Shelf Qty	5
Thermostat Type	Digital
Interior Light	Yes
Refrigerant Type	R600a
Refrigerant Amount	0.78 oz.
High Side PSI	270.0
Low Side PSI	105.0
Interior Height 1	21.25" (54 cm)
Interior Width 1	10.5" (27 cm)
Interior Depth 1	17.25" (44 cm)
Compressor Step Height	3.5" (9 cm)

Compressor Step Width	10.5" (27 cm)
Compressor Step Depth	5.0" (13 cm)
Level Legs	4
Temperature Range	41° to 64°F
Sabbath Mode	Yes
Sound Level	32.9 dB

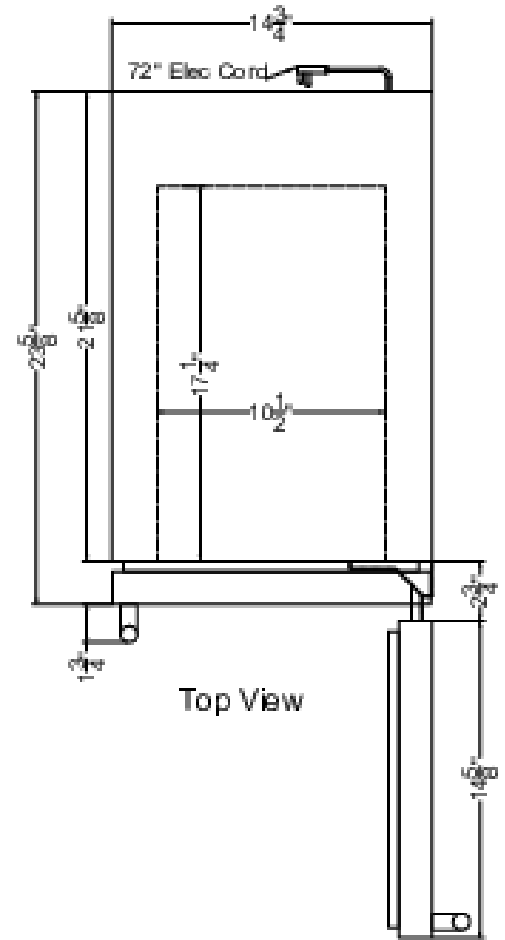

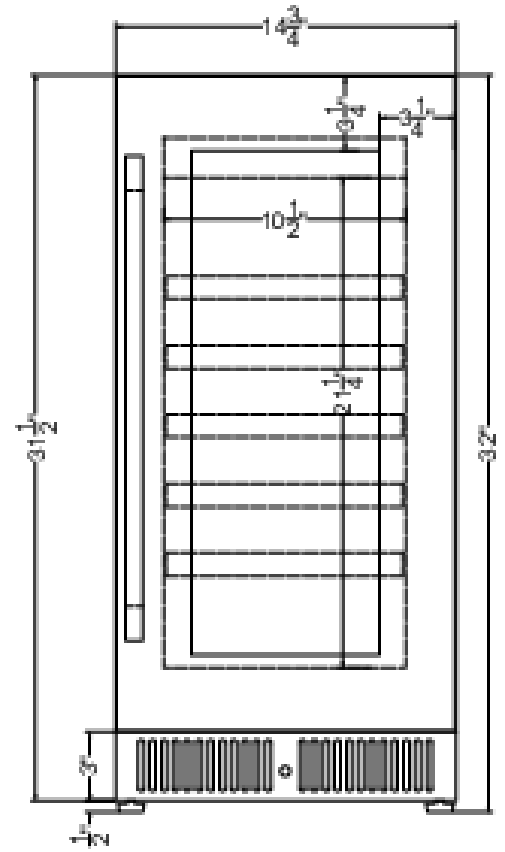

Front View