

INSTALLATION

Product Manual

Version: 150266US-01-25A-FC

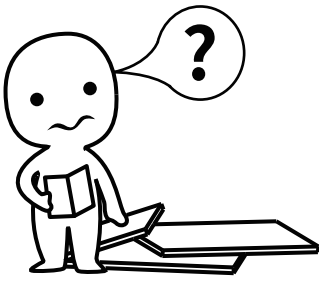

IMPORTANT INFORMATION!

please read the entire manual before starting to assemble and/or using this product. follow the manual thoroughly and keep it for further reference.

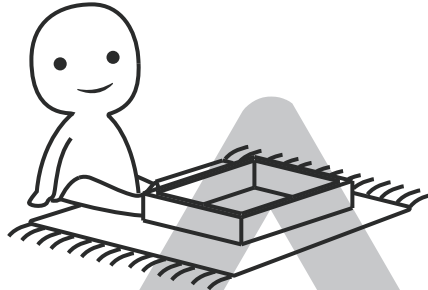
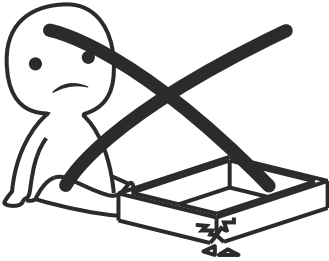

AVOID SCRATCHES!

In order to avoid scratching this furniture should be assembled on a soft layer- could be a rug.



IMPROVE EFFICIENCY !

Try to find a partner to install with you, which can speed up the installation efficiency and shorten the time.

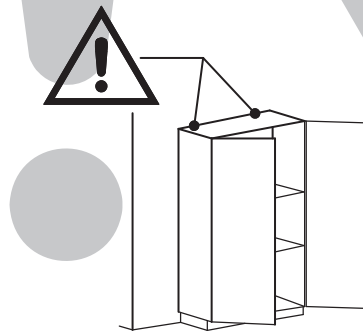
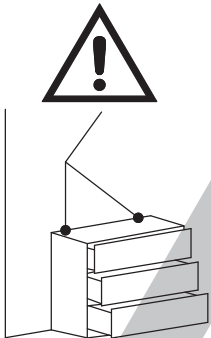

ANTI-TOPPLE WARNING !

Overturnd furniture can cause serious or fatal crush injuries. To prevent tipping over, be sure to use the wall attachment, if not included with this product. Please purchase the wall attachment that fit your wall. If unsure, seek professional advice. Please read and follow each step of the instructions carefully.

IMPORTANT !

It is important that any product which is assembled using any kind of screw is re-tightened 2 weeks after assembly, and once every 3 months - in order to assure stability through-out the lifespan of the product.

For regular maintenance and cleaning of the product, for the frame, please use a rag dipped in neutral detergent to fully wipe it, and then dry it with a clean rag. For glass materials, wipe with a rag dampened with water glass cleaner, and then dry with a dry rag.

Do not use an electric screwdriver, and do not use too much force when installing, because the board is easy to break.



Please prepare the following tools

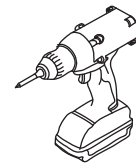
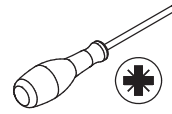
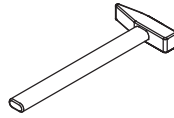
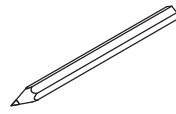

When installing, please carefully confirm whether each screw corresponds to the manual, accessories with similar shapes can be distinguished by size

A x 182+5

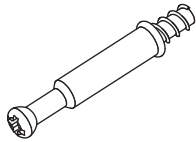

Ø 6 x 35 mm

B x 182+5



Ø 15 x 11 mm

C x 132+5

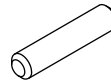

Ø 8 x 30 mm

D x 6

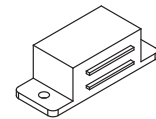

E x 40+3

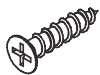

Ø 3 x 12 mm

F x 6

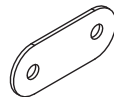

G x 12+1

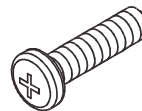

Ø 6 x 25 mm

H x 28+4



J x 20+4



Ø 4 x 25 mm

K x 182+5

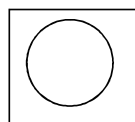

L x 12+1



Ø 3 x 14 mm

M x 12



N x 12

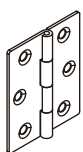

x48

Ø 3 x 12 mm

P x 6

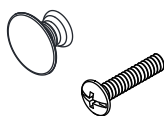

Ø 4 x 22 mm

Q x 2

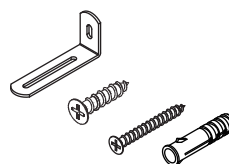

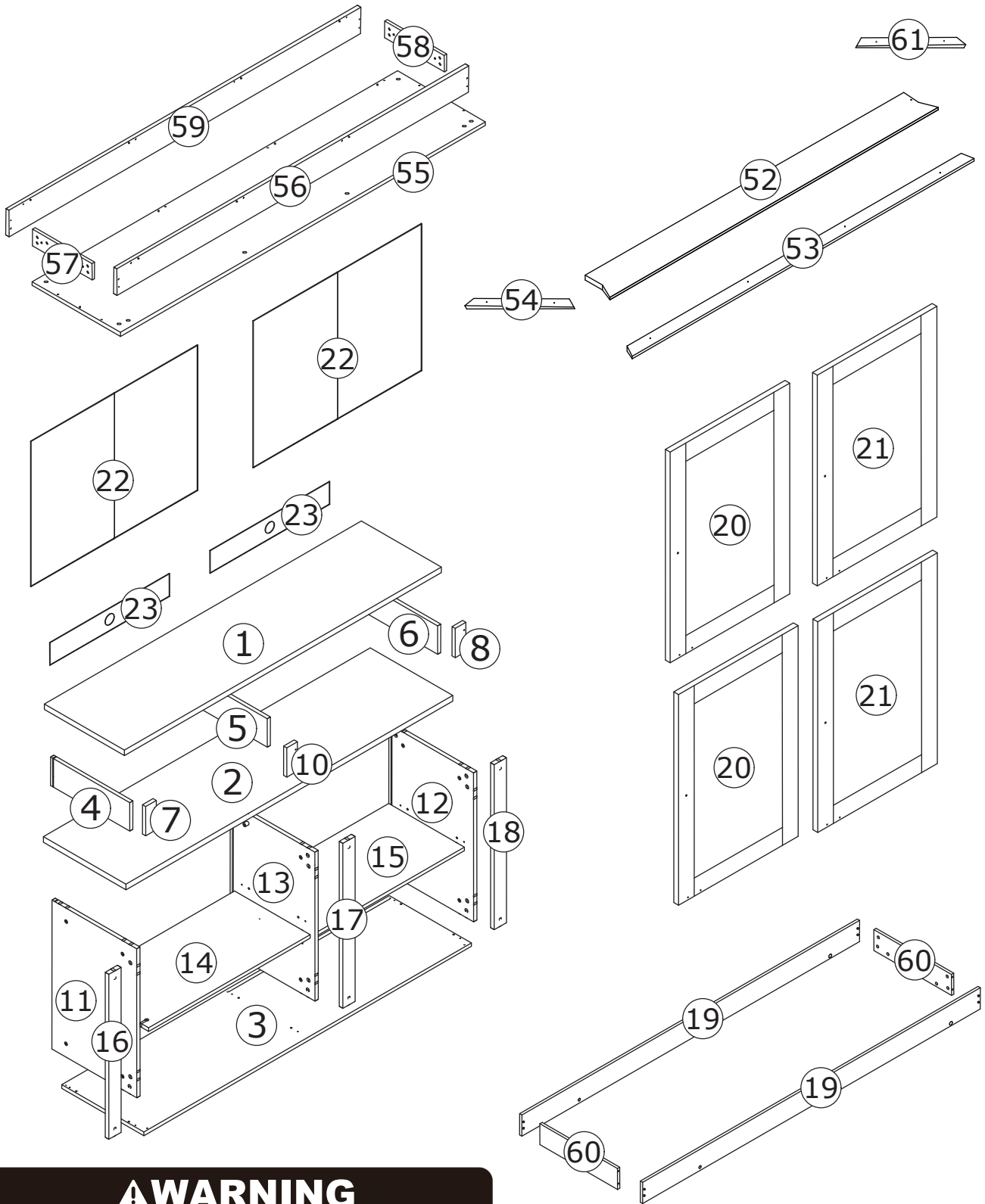

⚠ WARNING



Children have died from furniture tipover. To reduce the risk of furniture tipover:

- ALWAYS install Anti-tip device provided.
- NEVER put a TV on this product.
- NEVER allow children to stand, climb or hang on drawers, doors, or shelves.
- NEVER open more than one drawer at a time.
- Place heaviest items in the lowest drawers.

*This is a permanent label.
Do not remove!*

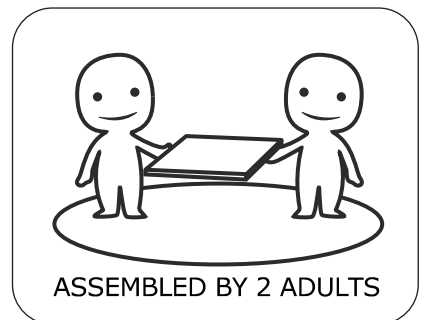

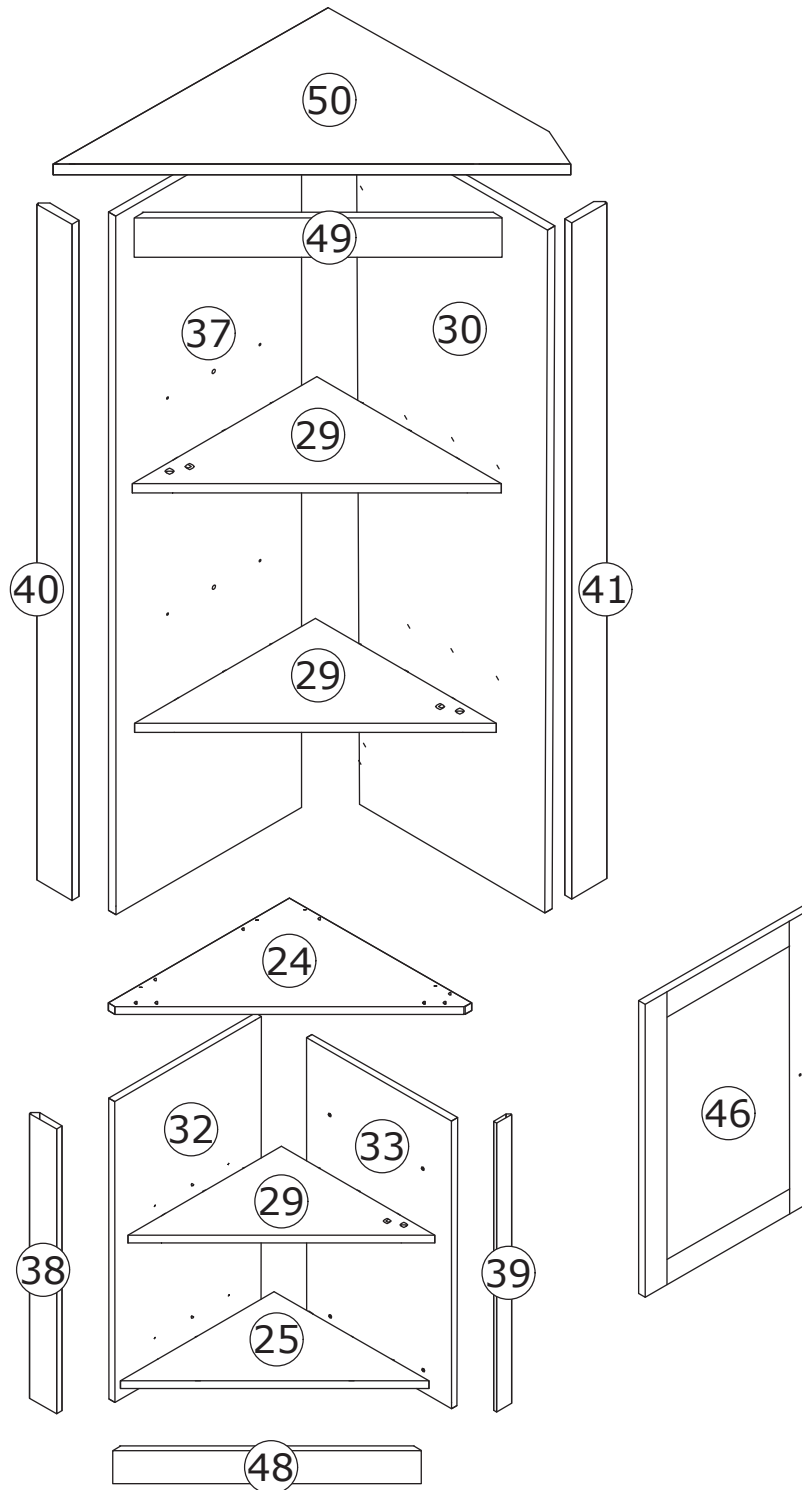

⚠ WARNING



Children have died from furniture tipover. To reduce the risk of furniture tipover:

- ALWAYS install Anti-tip device provided.
- NEVER put a TV on this product.
- NEVER allow children to stand, climb or hang on drawers, doors, or shelves.
- NEVER open more than one drawer at a time.
- Place heaviest items in the lowest drawers.

*This is a permanent label.
Do not remove!*

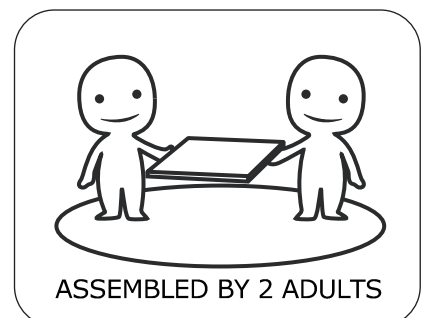

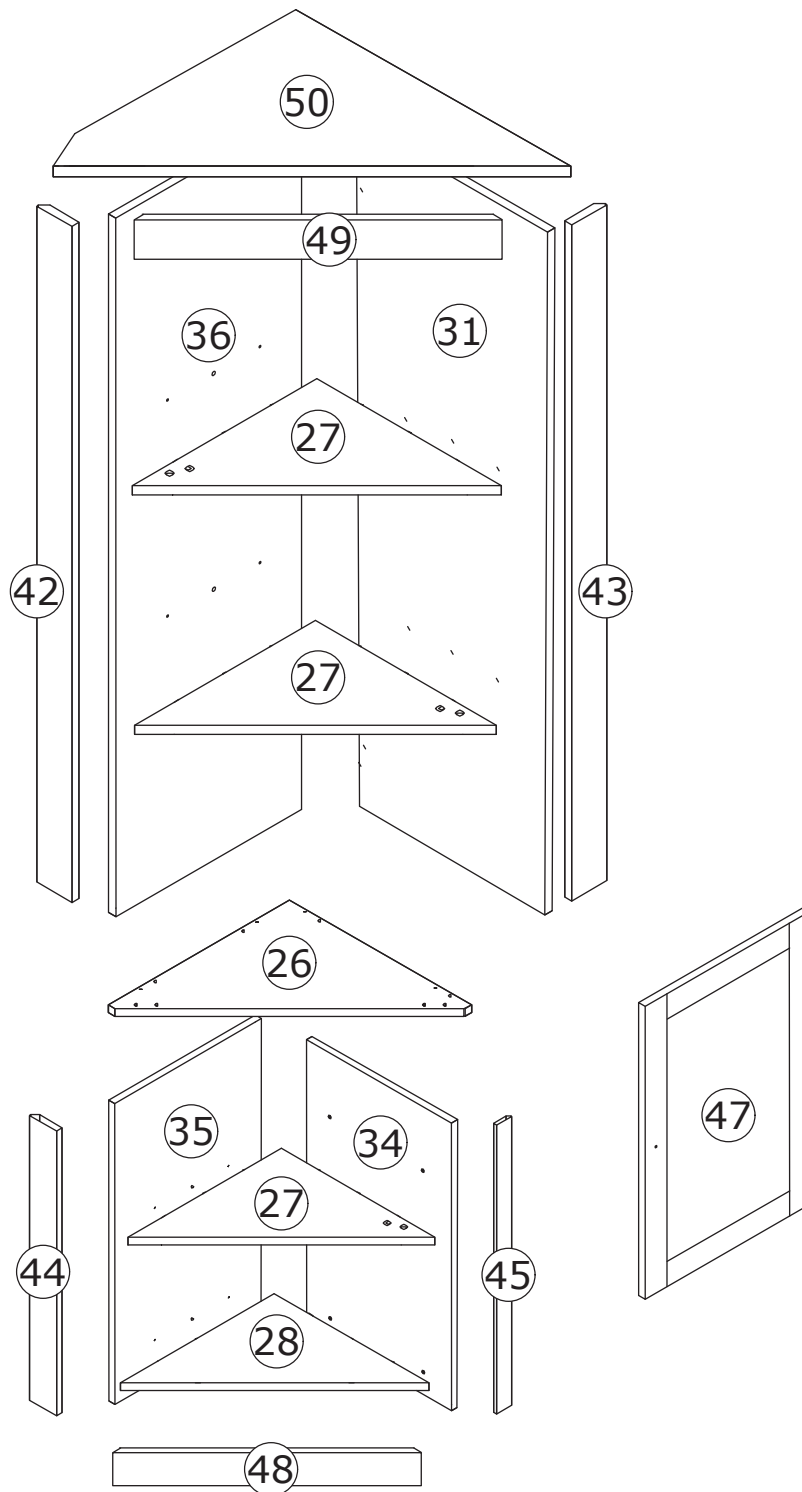

⚠ WARNING



Children have died from furniture tipover. To reduce the risk of furniture tipover:

- ALWAYS install Anti-tip device provided.
- NEVER put a TV on this product.
- NEVER allow children to stand, climb or hang on drawers, doors, or shelves.
- NEVER open more than one drawer at a time.
- Place heaviest items in the lowest drawers.



*This is a permanent label.
Do not remove!*

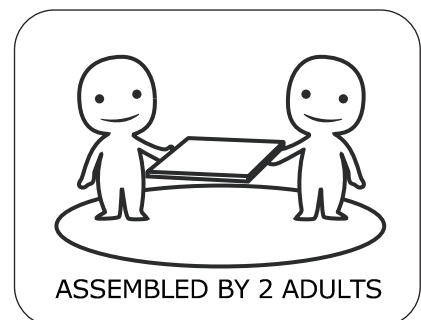

1

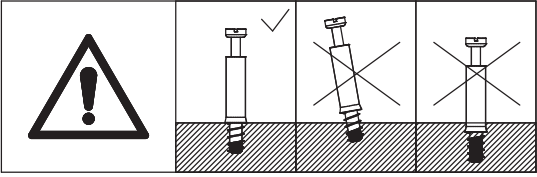
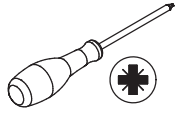
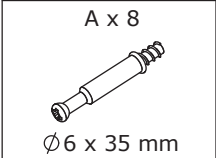

Screw eccentric rod (A) into plate 19 as shown.

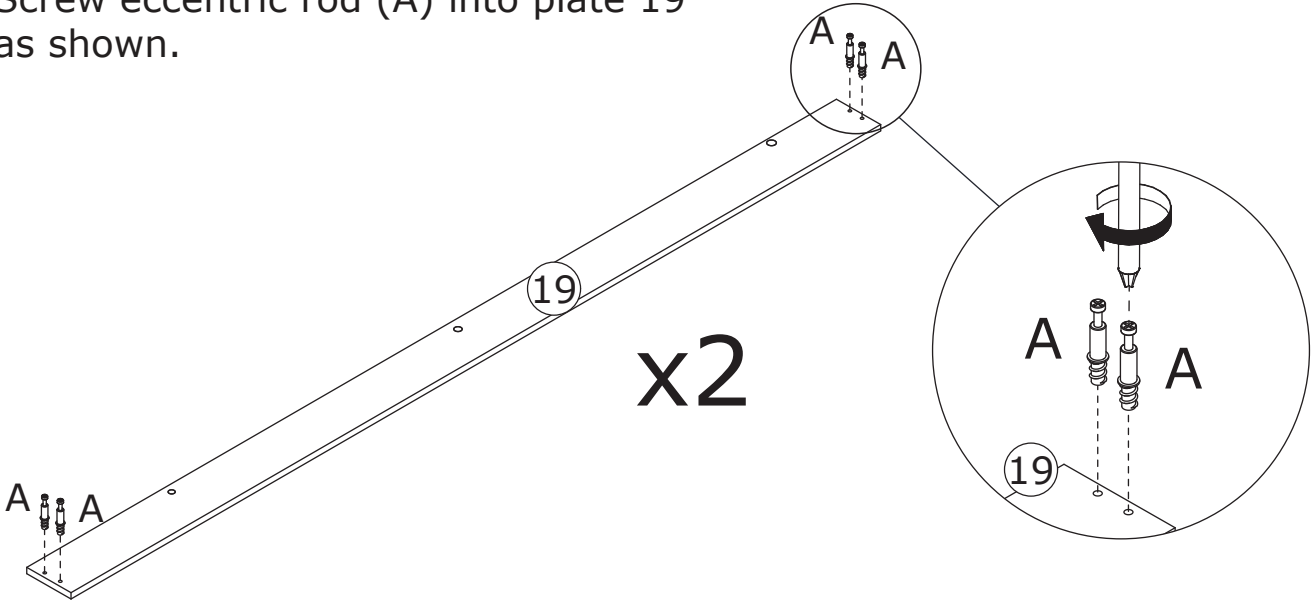

2

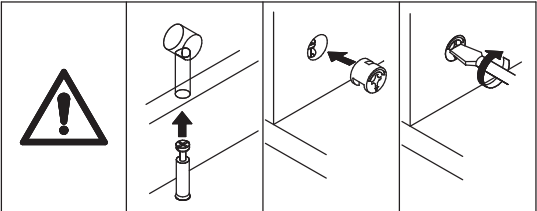
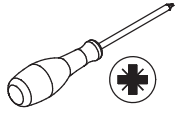
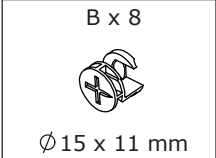

Connect plate 19 to plate 60, add cam lock (B) into plate 60, then turn clockwise and tighten as shown.

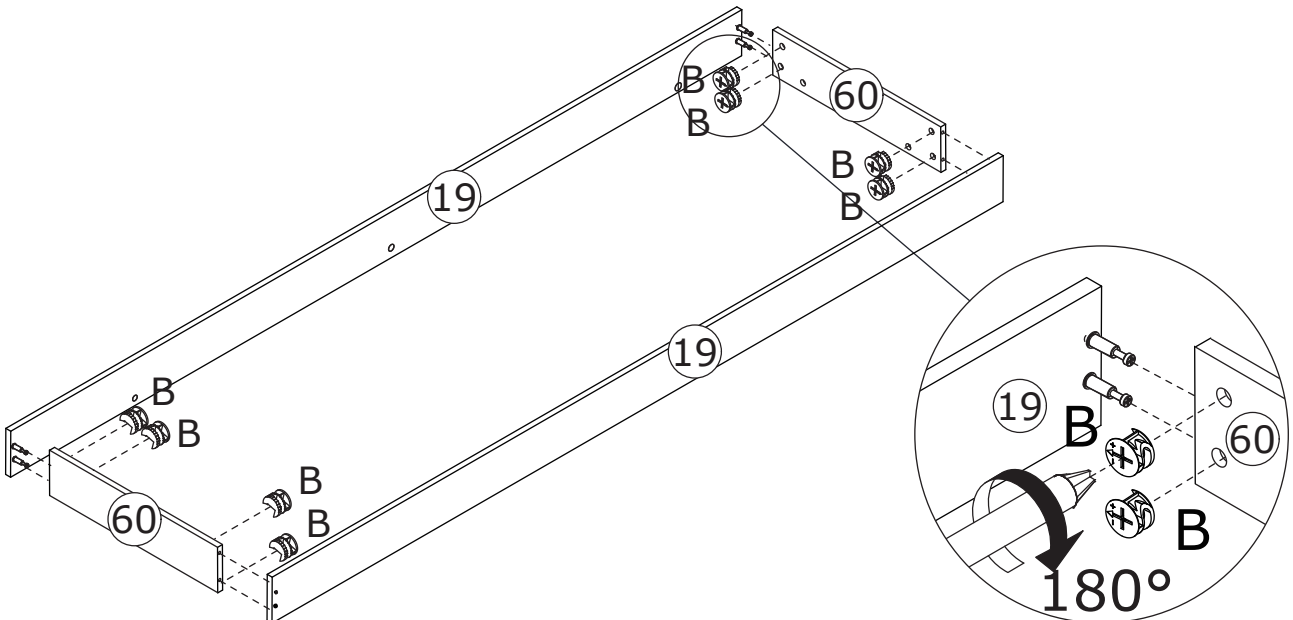

3

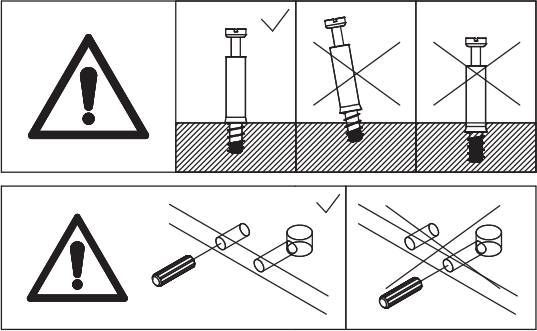
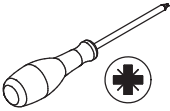
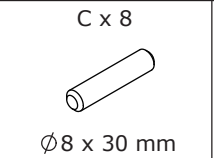
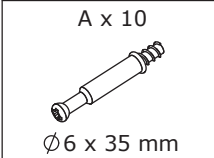

Screw eccentric rod (A) and insert wooden dowel (C) into plate 3 as shown.

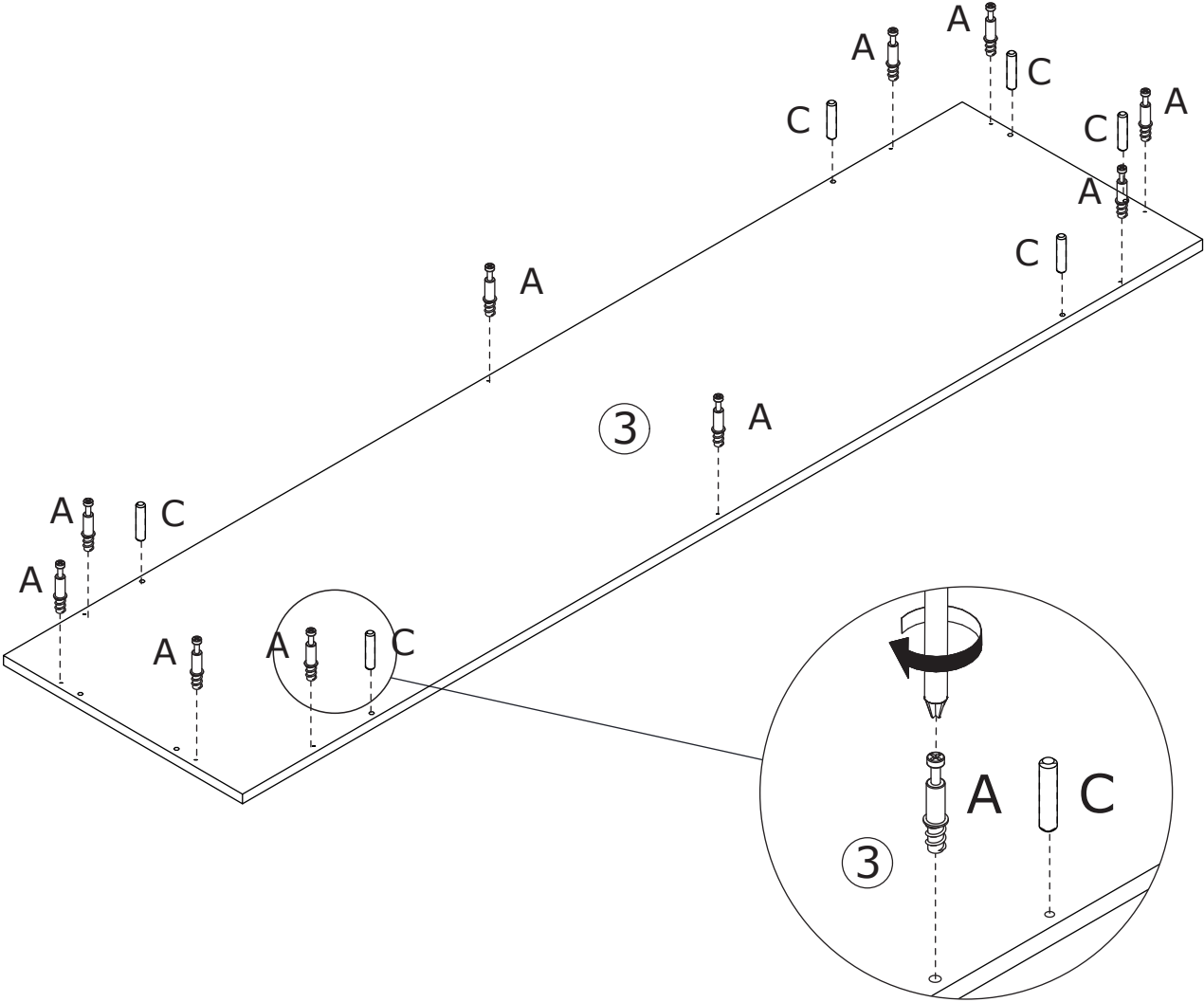

4

B x 10
Ø 15 x 11 mm

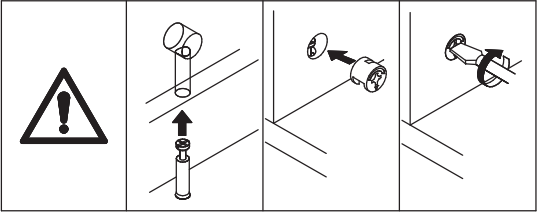
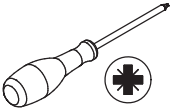

Connect plate 19 and 60 to plate 3, add cam lock (B) into plate 19 and 60, then turn clockwise and tighten as shown.

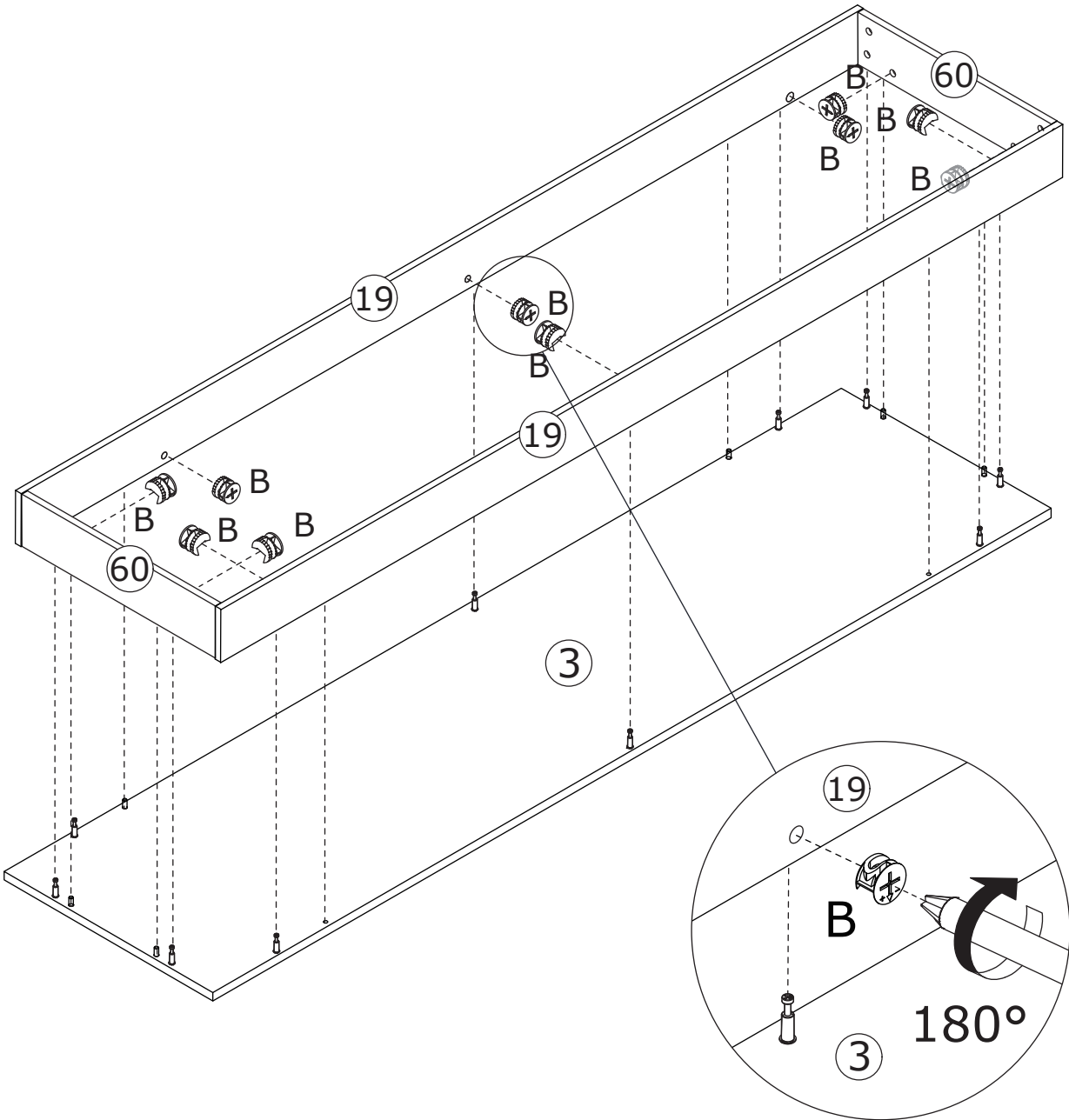

5

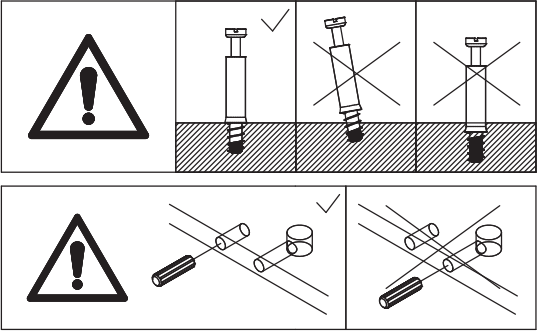
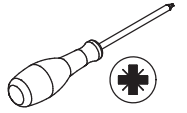
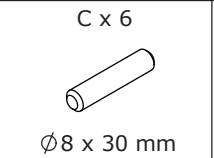
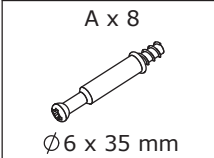

Screw eccentric rod (A) and insert wooden dowel (C) into plate 3 as shown.

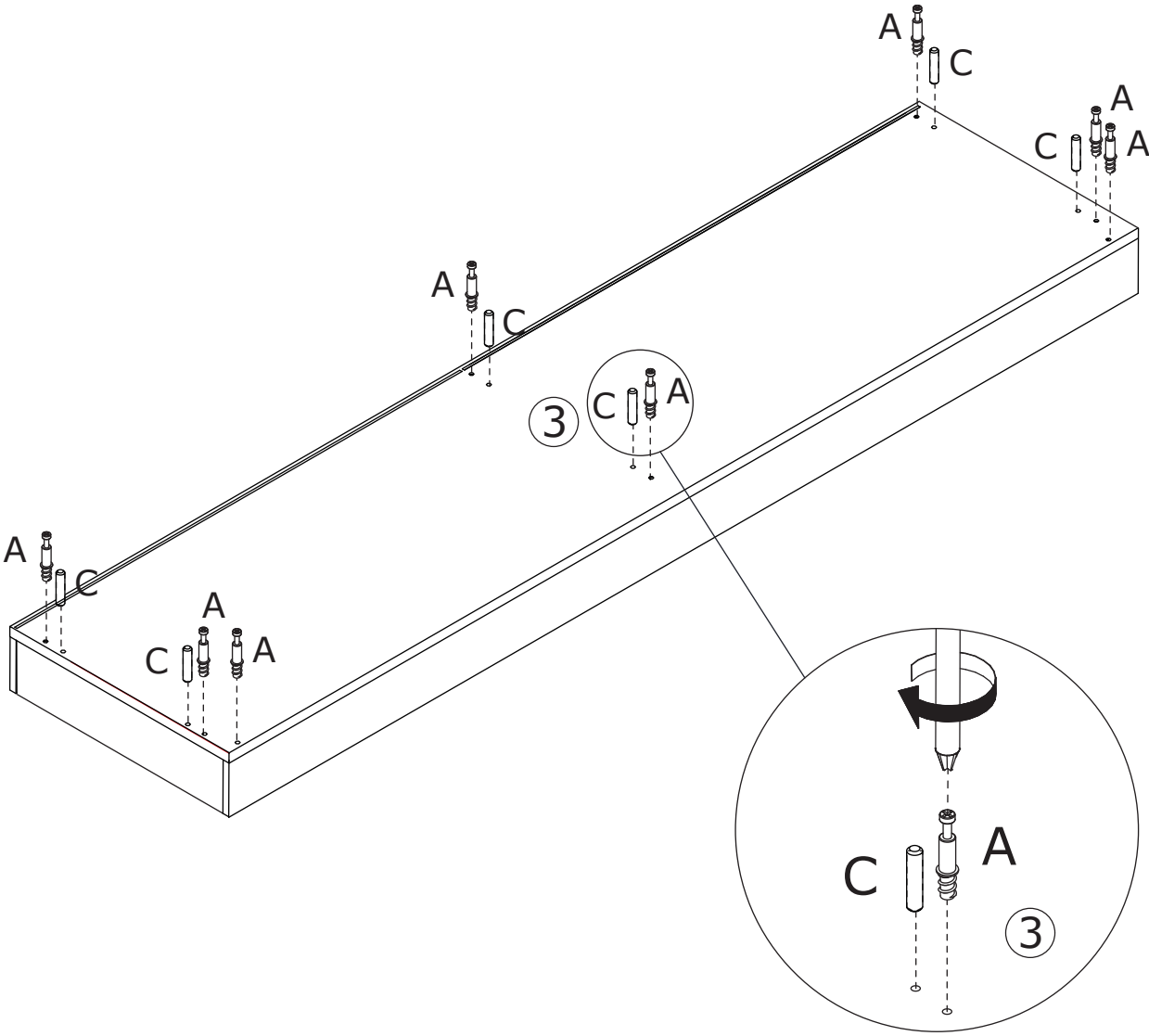

6

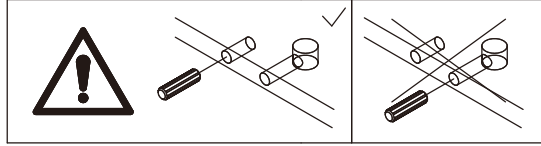
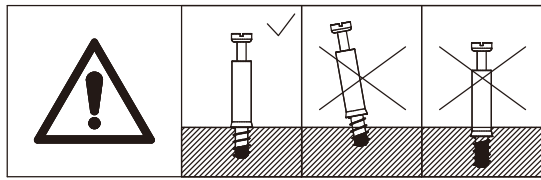
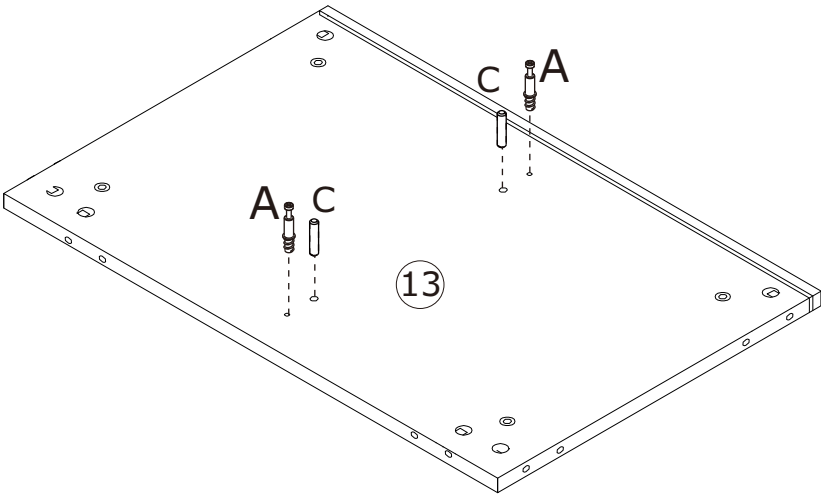
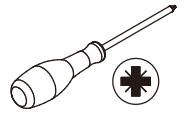
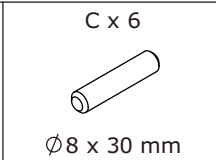
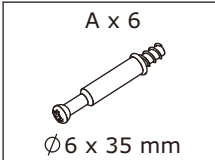

Screw eccentric rod (A) and insert wooden dowel (C) into plate 13, 12 and 11 as shown.

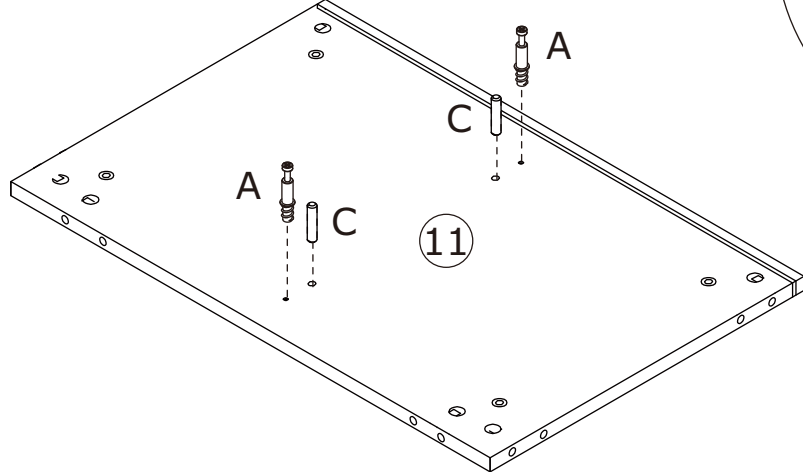
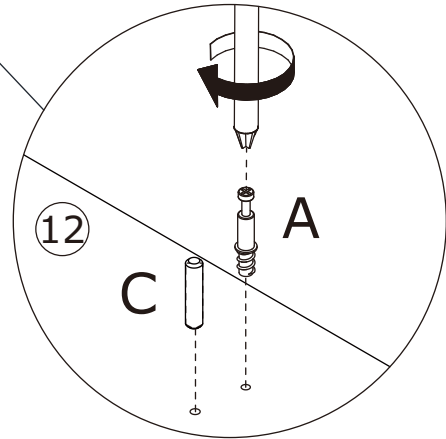
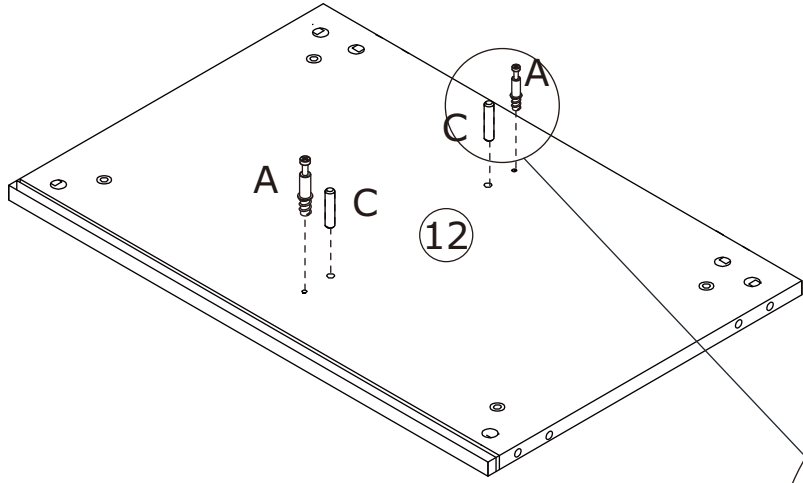

7

B x 4
Ø15 x 11 mm

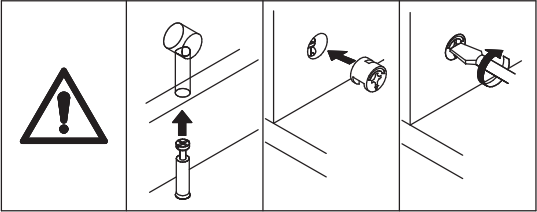
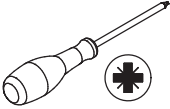

Connect plate 14 to plate 11 and 13, then turn cam lock (B) clockwise to tighten as shown.

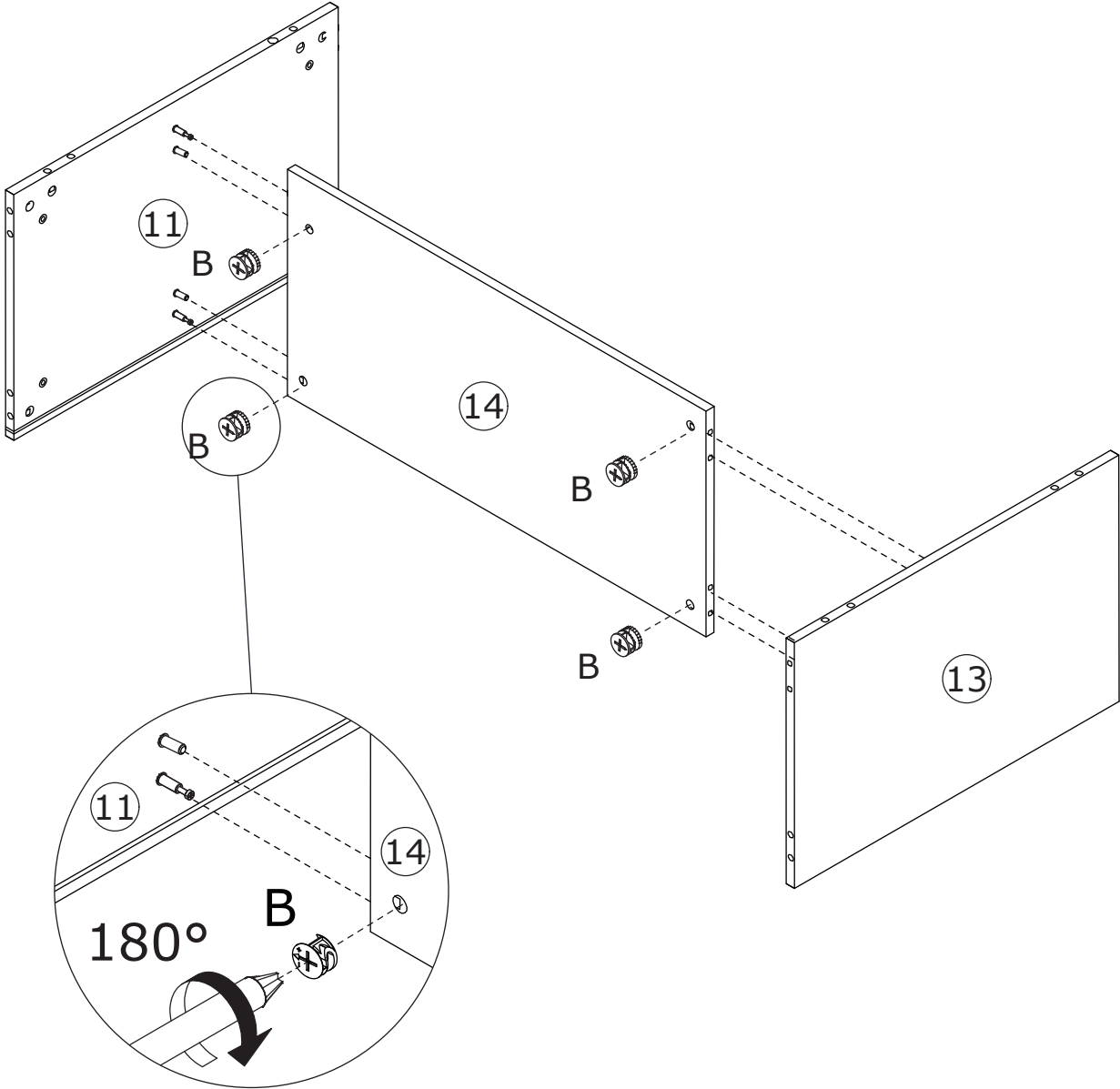

8

B x 4
Ø15 x 11 mm

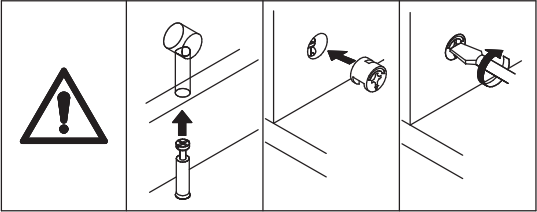

Connect plate 13 and 12 to plate 15, then turn cam lock (B) clockwise to tighten as shown.

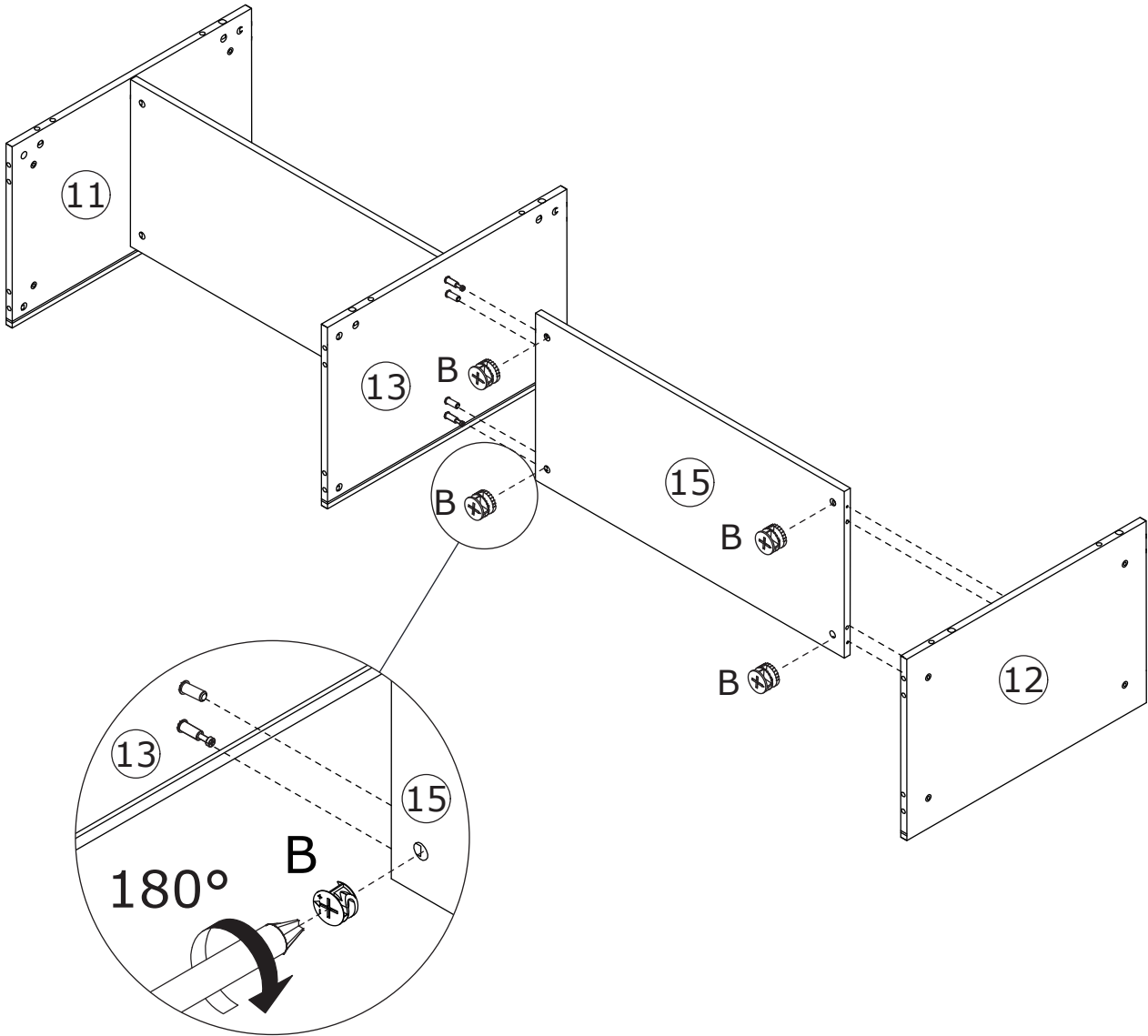

9

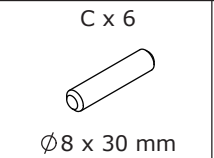
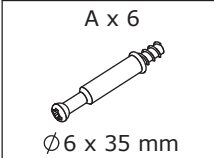

Screw eccentric rod (A) and insert wooden dowel (C) into plate 17, 16, and 18 as shown.

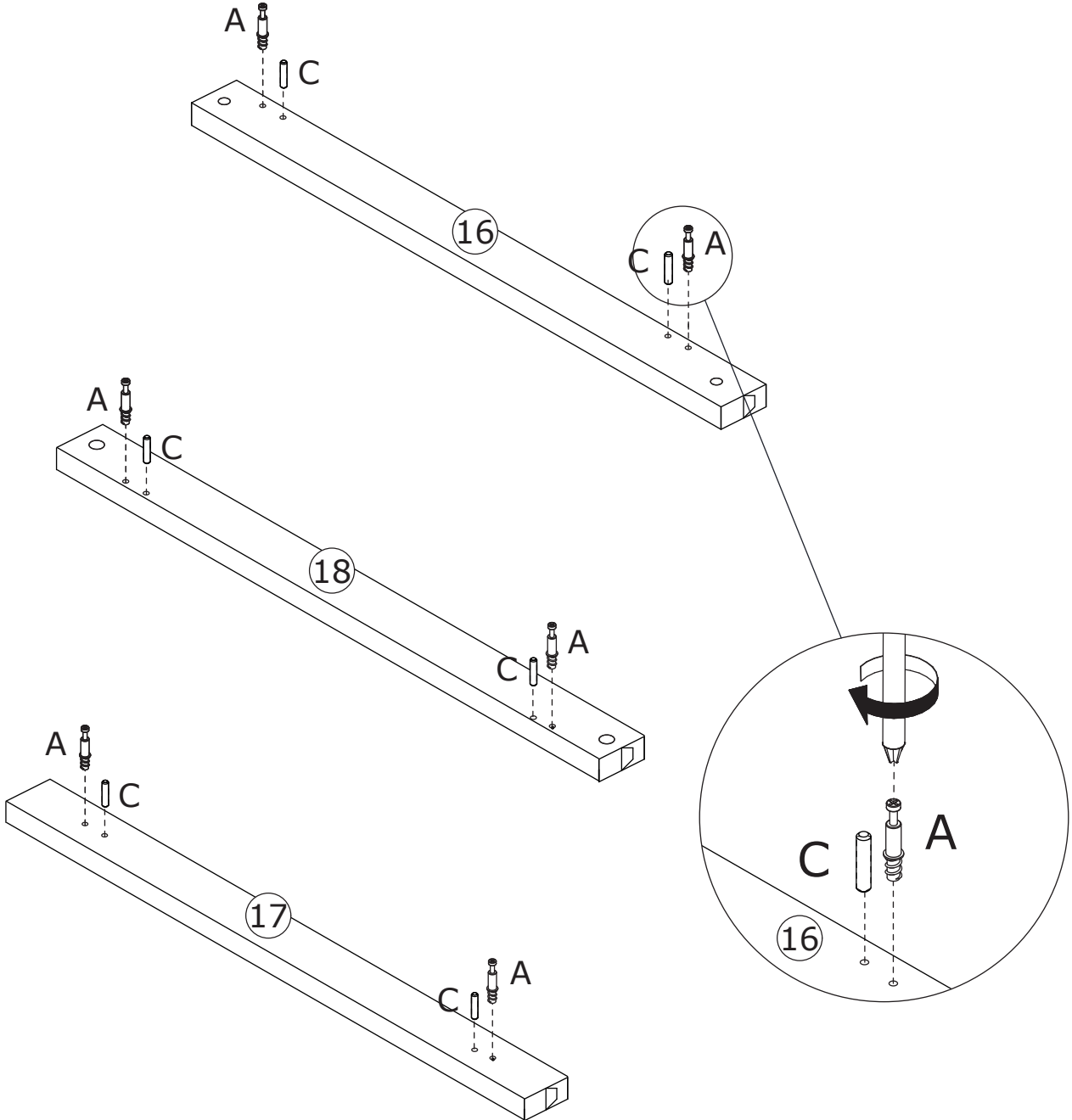
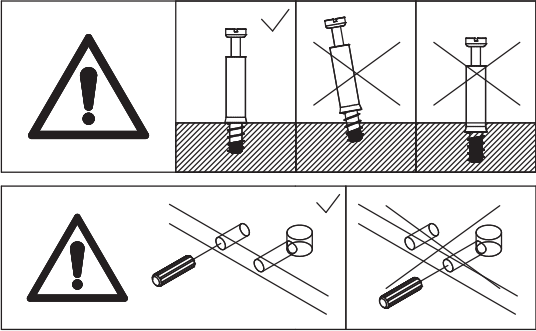

10

B x 6
Ø15 x 11 mm

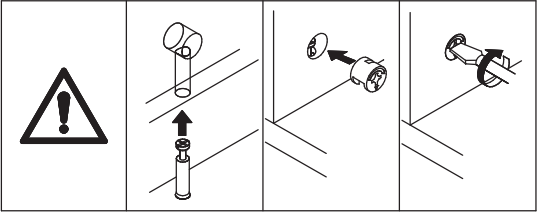

Attach plate 16, 17, and 18 to plate 11, 13, and 12, then turn cam lock (B) clockwise to tighten as shown.

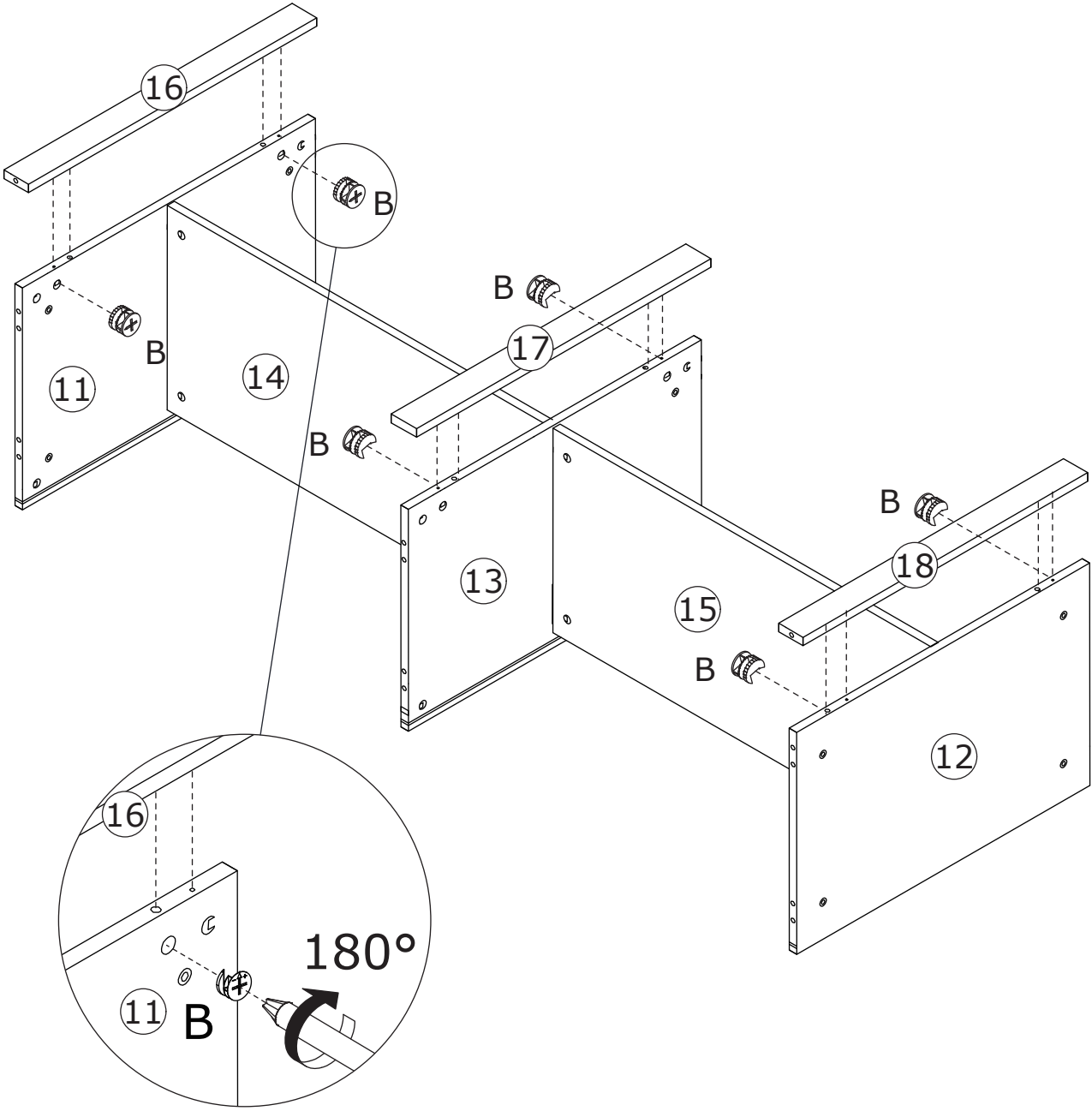

11

B x 6
Ø15 x 11 mm

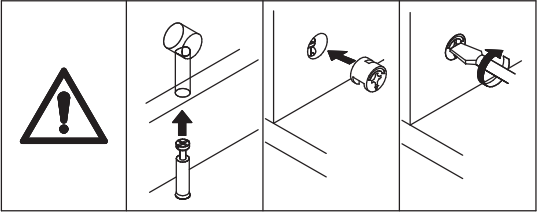

Connect plate 3 to plate 11, 13, and 12, then turn cam lock (B) clockwise to tighten as shown.

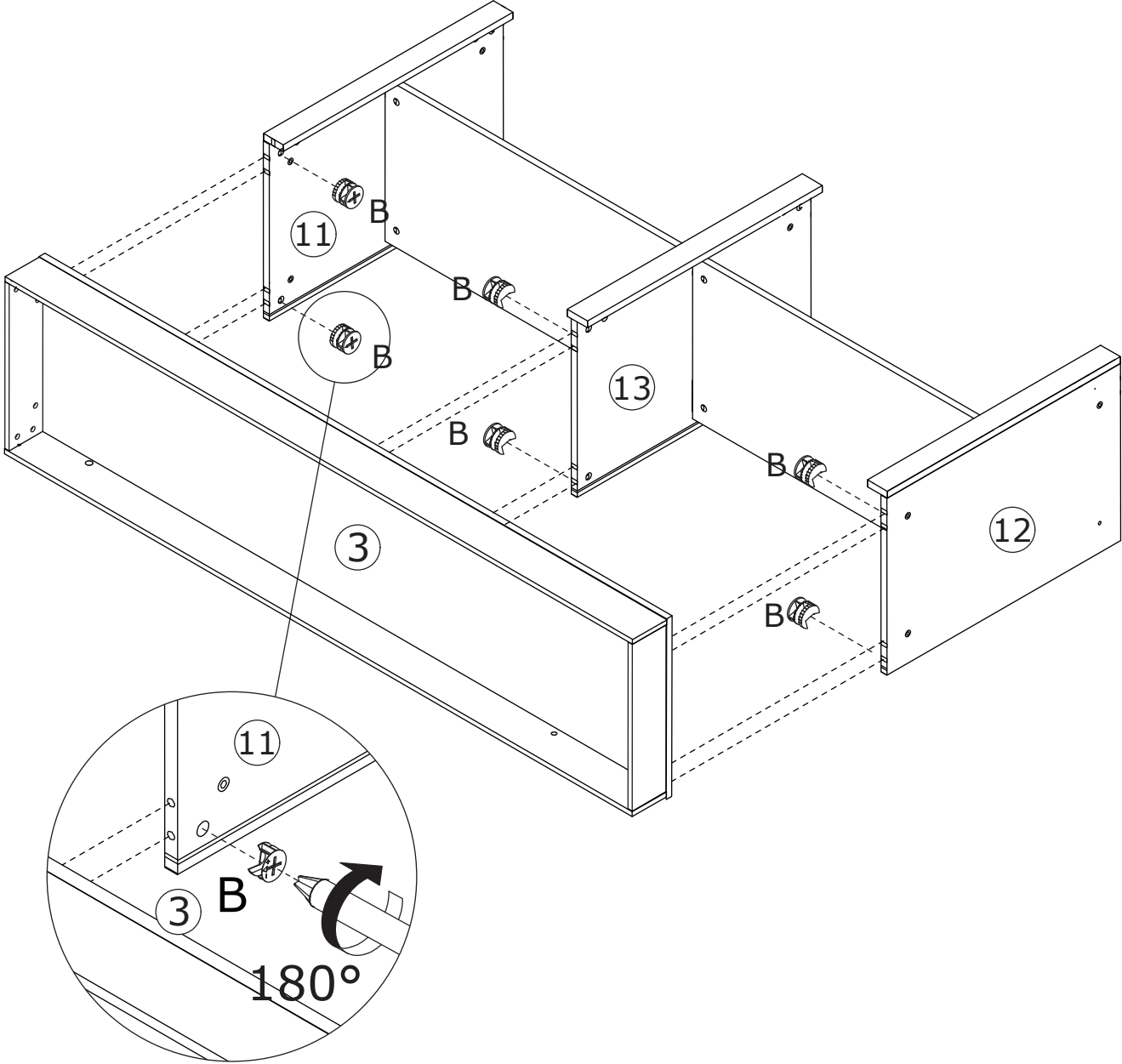



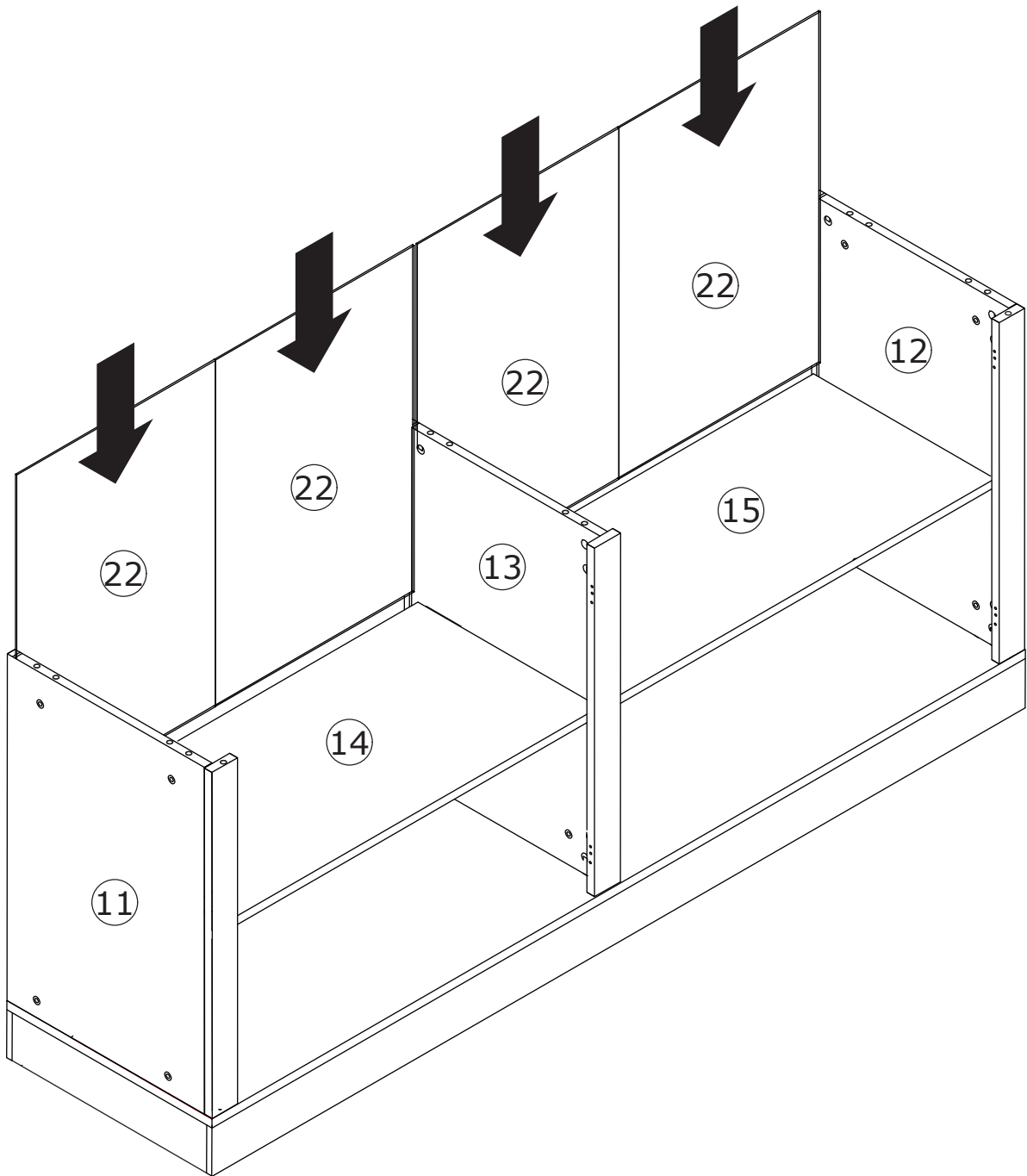

12

Insert back plate 22 along the grooves.

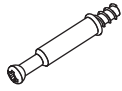

13

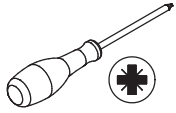
 A x 6 Ø6 x 35 mm	 C x 6 Ø8 x 30 mm	 D x 4	 L x 8 Ø3 x 14 mm	
--	--	--	---	---

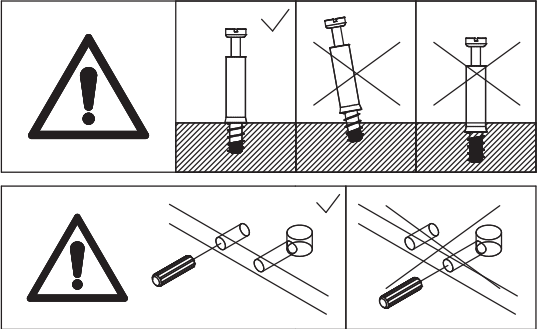

Screw eccentric rod (A) and insert wooden dowel (C) into plate 2 as shown.
Fix magnet (D) with screw(L).

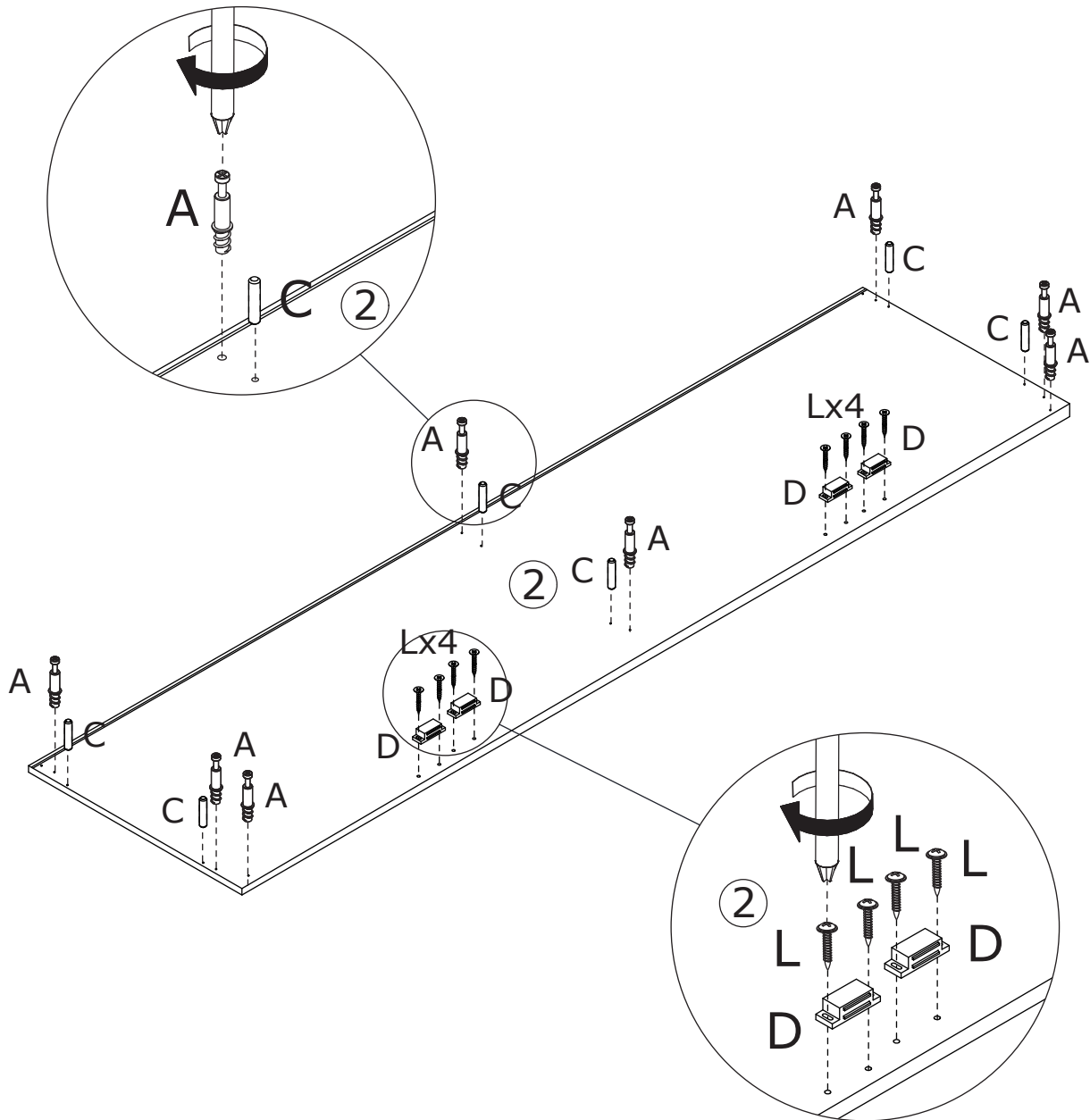

14

B x 8
Ø15 x 11 mm

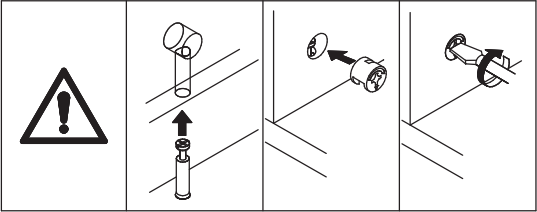

Connect plate 2 to plate 11, 13, and 12, then turn cam lock (B) clockwise to tighten as shown.

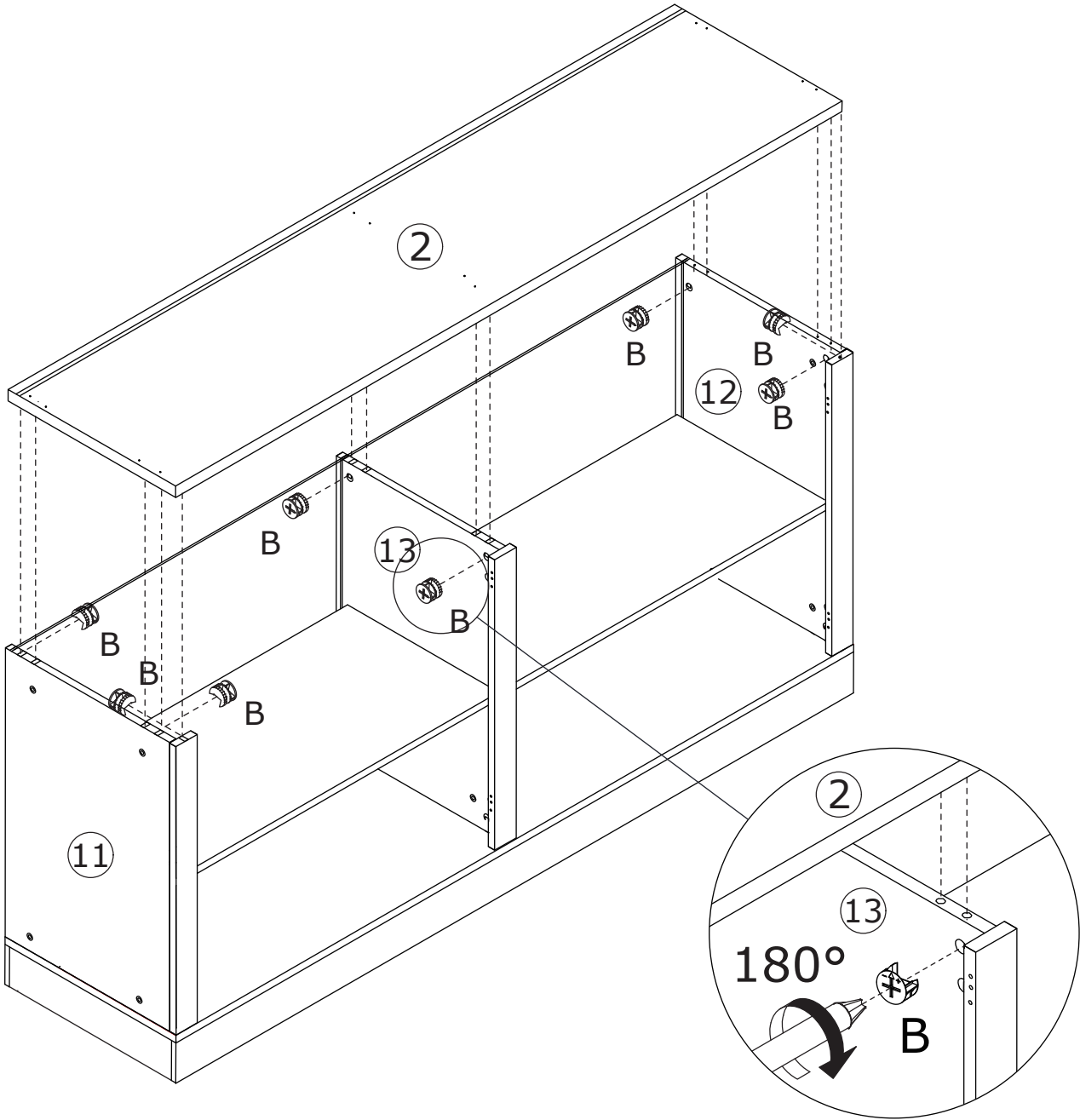

15

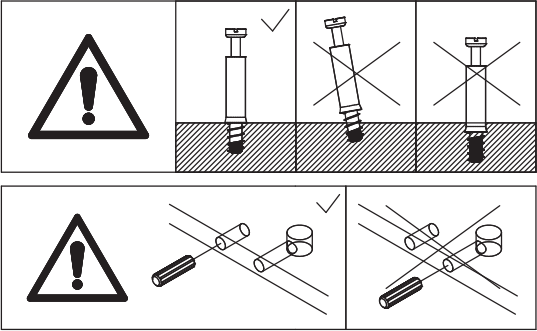

Screw eccentric rod (A) and insert wooden dowel (C) into plate 2 as shown.

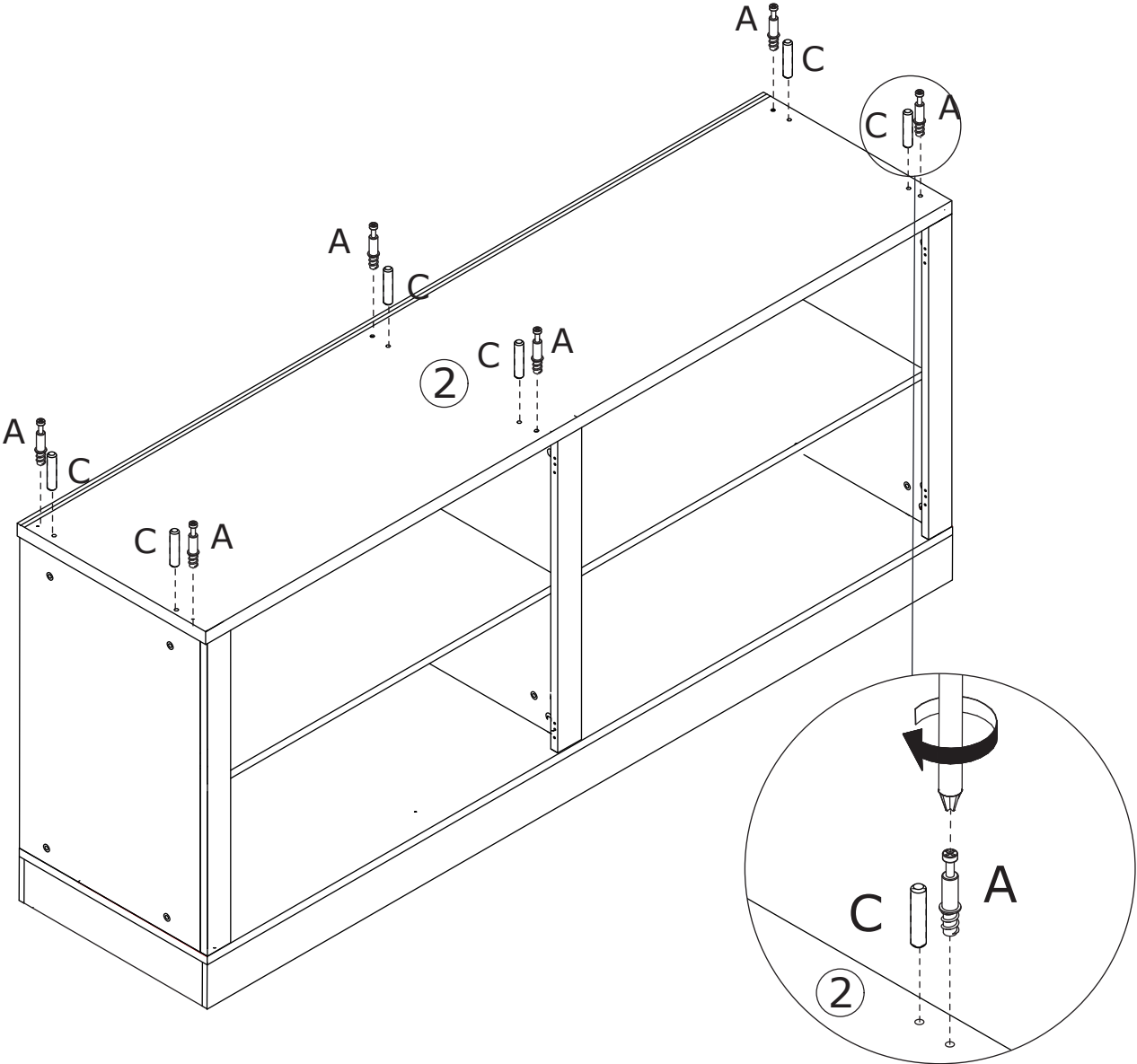

16

B x 6
Ø15 x 11 mm

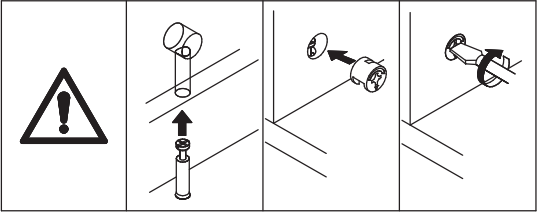
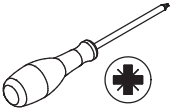

Attach plate 4, 5, and 6 to plate 2, then turn cam lock (B) clockwise to tighten as shown.

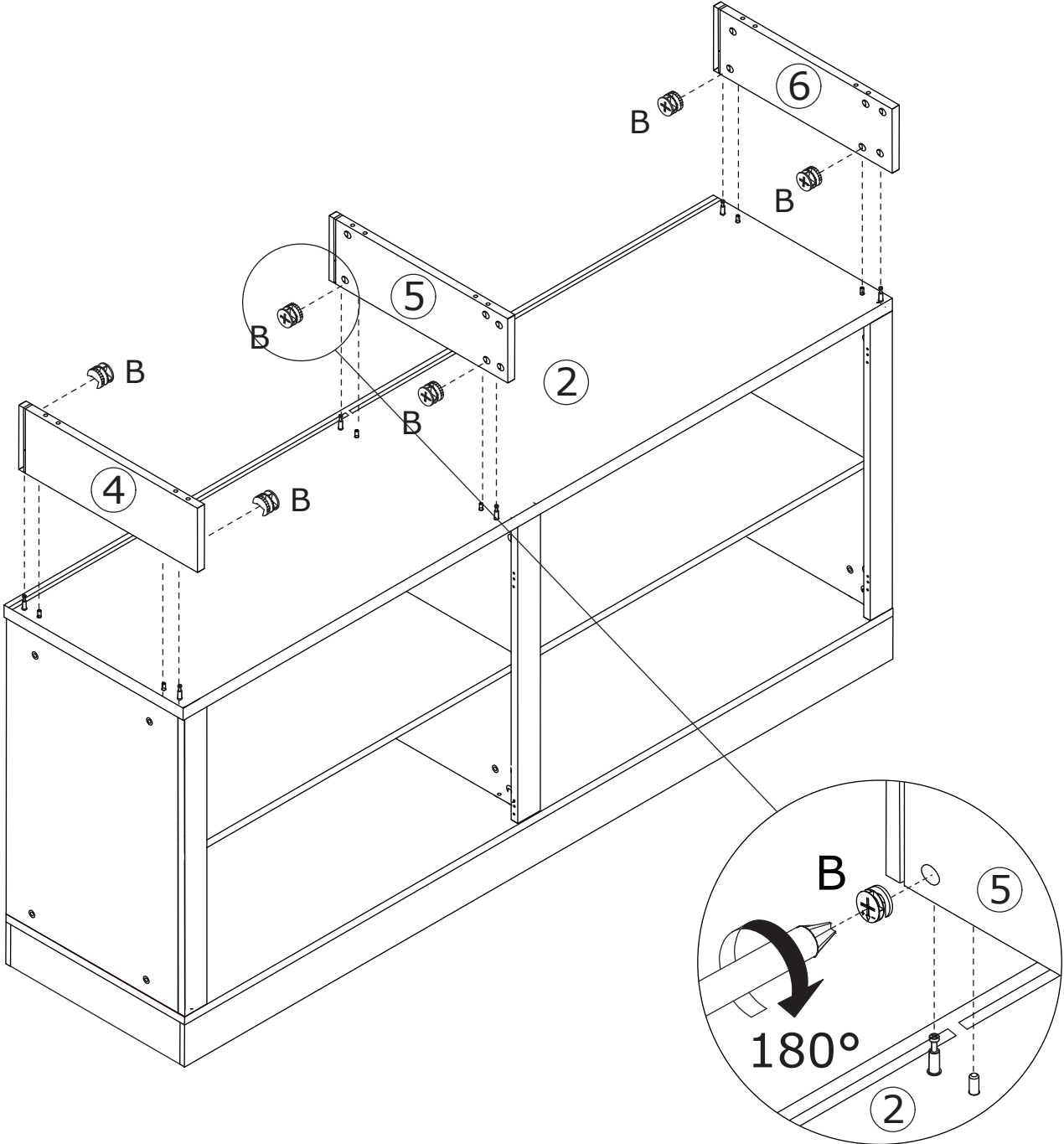

17

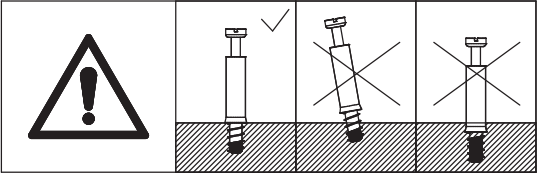
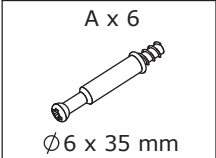

Screw eccentric rod (A) into plate 7, 8, and 10 as shown.

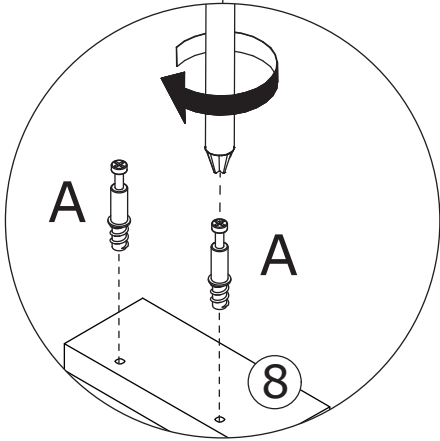
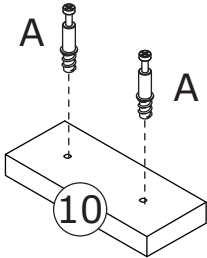
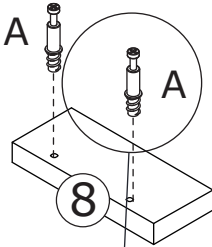
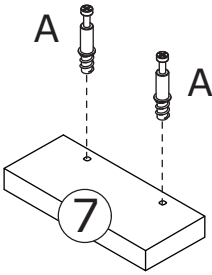

18

B x 6
Ø15 x 11 mm

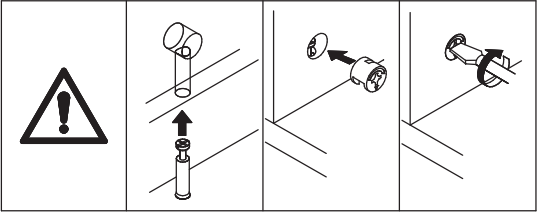
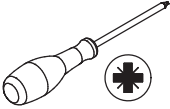

Attach plate 7, 8, and 10 to plate 4, 5, and 6, then turn cam lock (B) clockwise to tighten as shown.

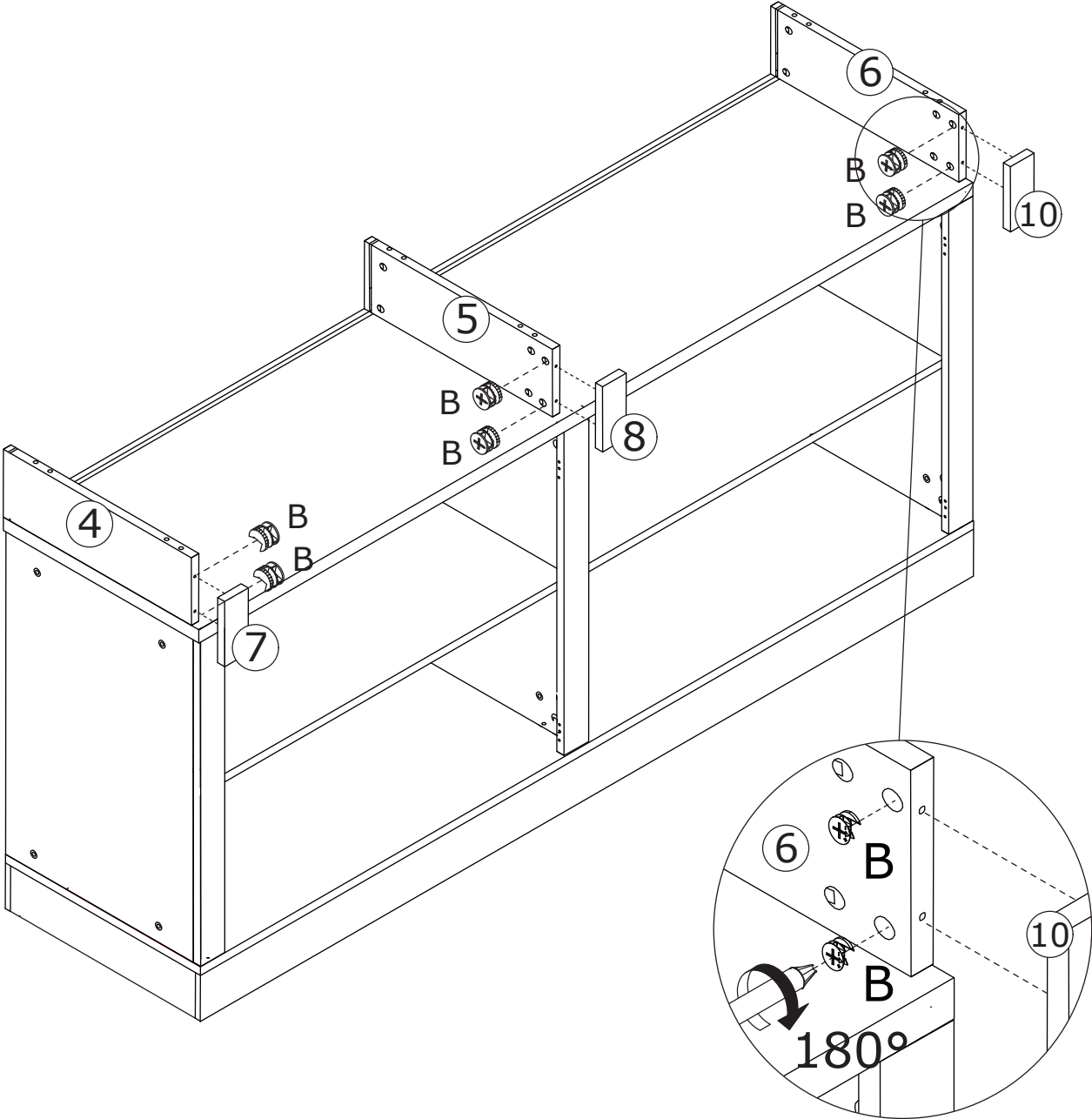

19

Insert back plate 23 along the grooves as shown.

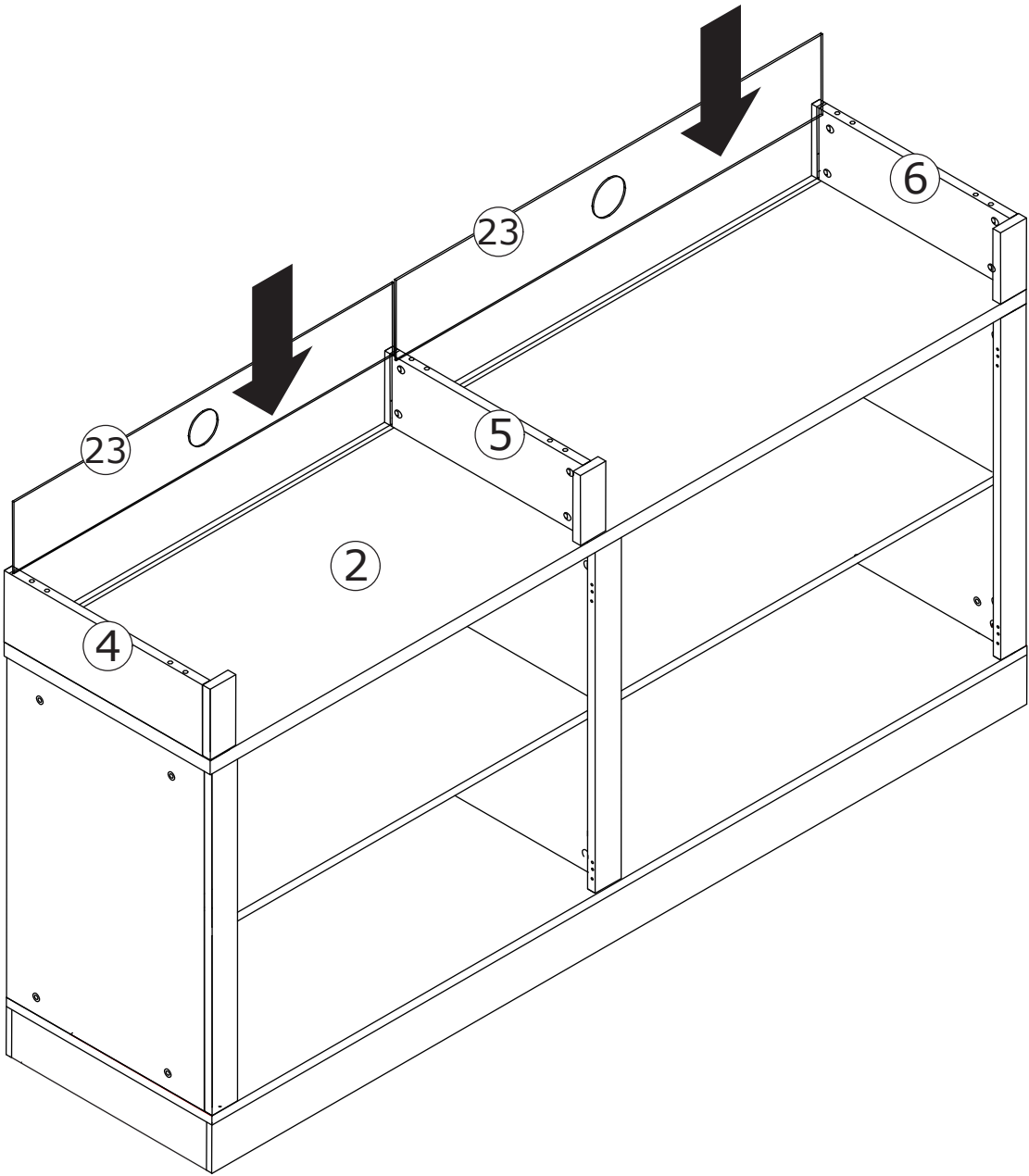

20

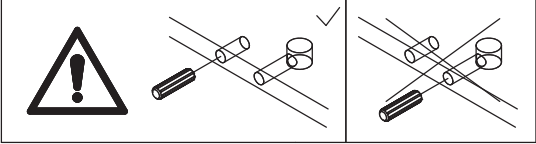
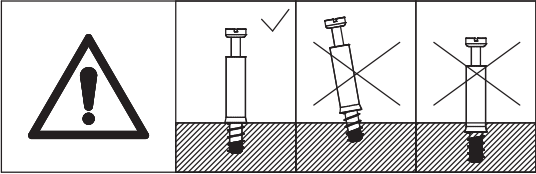
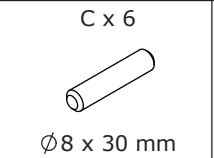
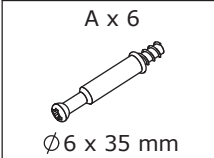

Screw eccentric rod (A) and insert wooden dowel (C) into plate 1 as shown.

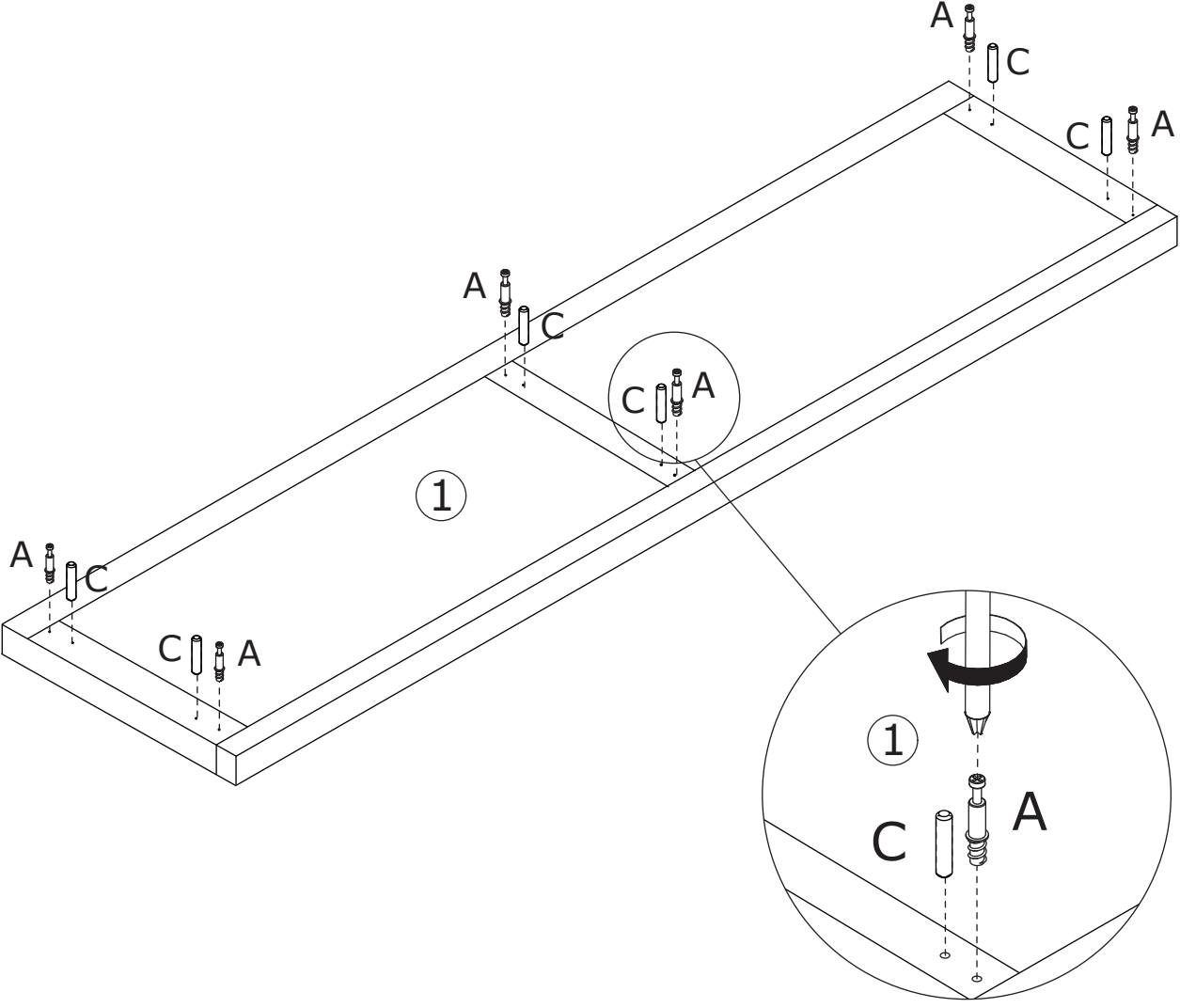

21

B x 6
Ø 15 x 11 mm

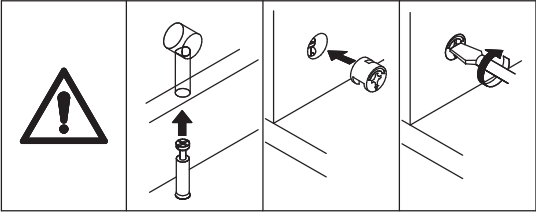
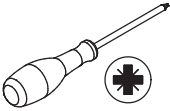

Cover plate 1 to plate 4, 5, and 6, then turn cam lock (B) clockwise to tighten as shown.

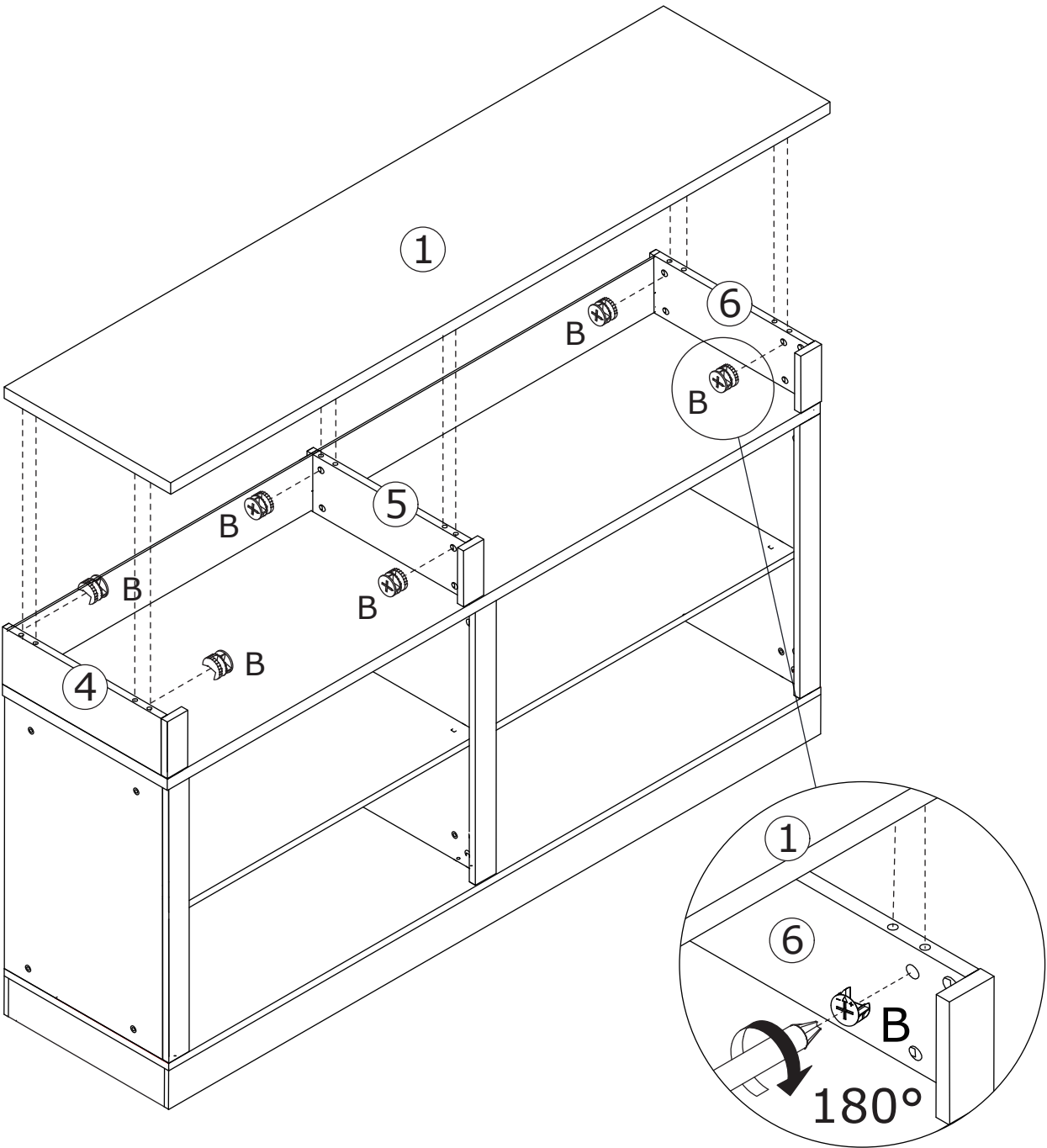

23

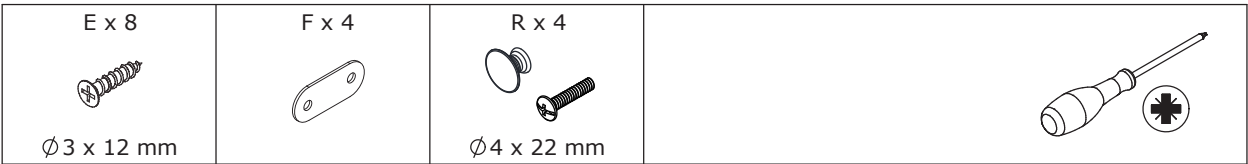

Use screws to fix hinge (N) and knob (R) to plate 20 and 21 as shown.
Then, fix part (F) with screw (E).

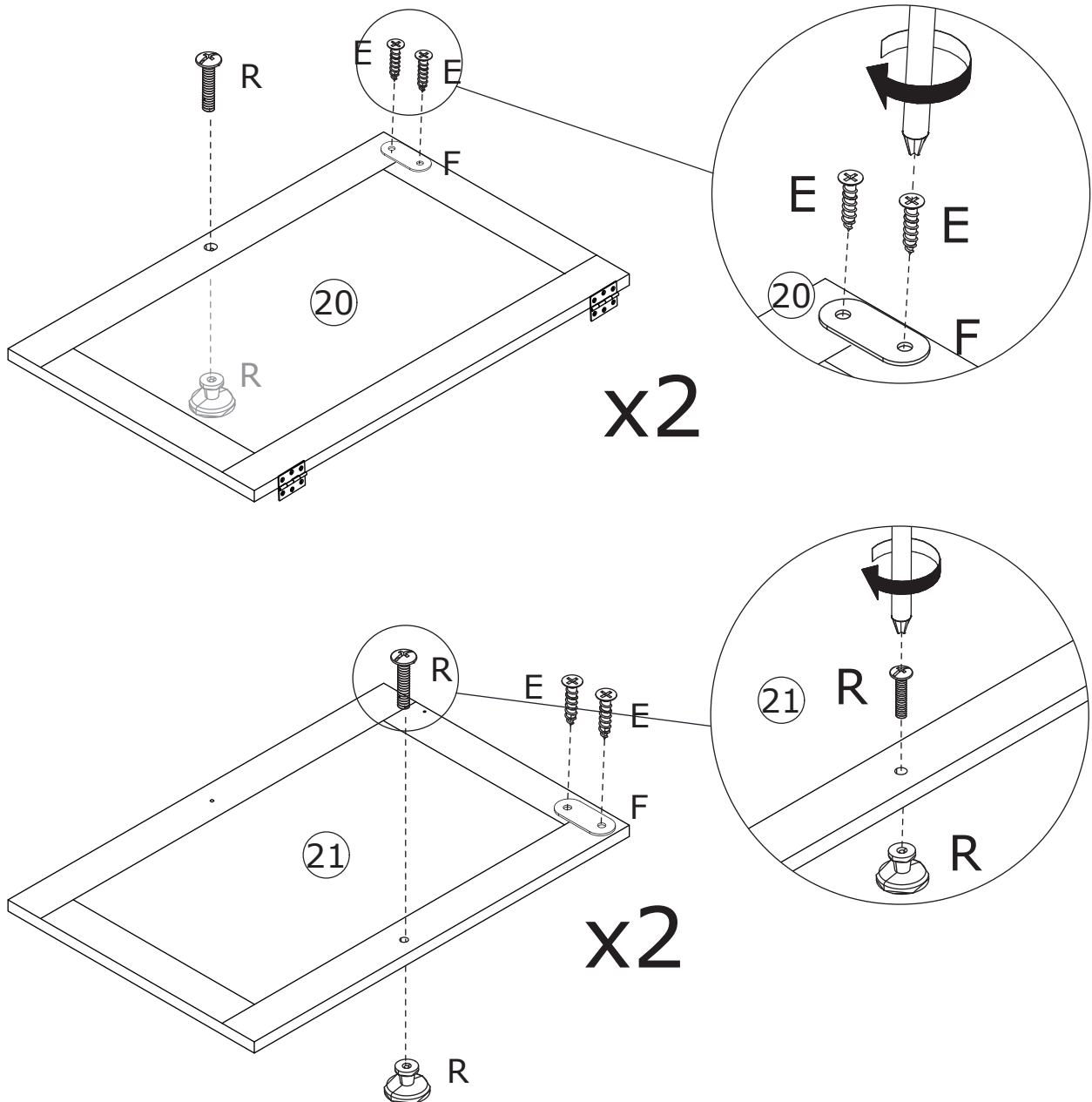

24

N x 24



Ø3 x 12 mm

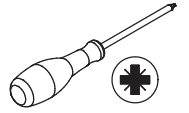

Use screw (N) to secure the installed hinges to plate 11, 12, and 13 as shown.

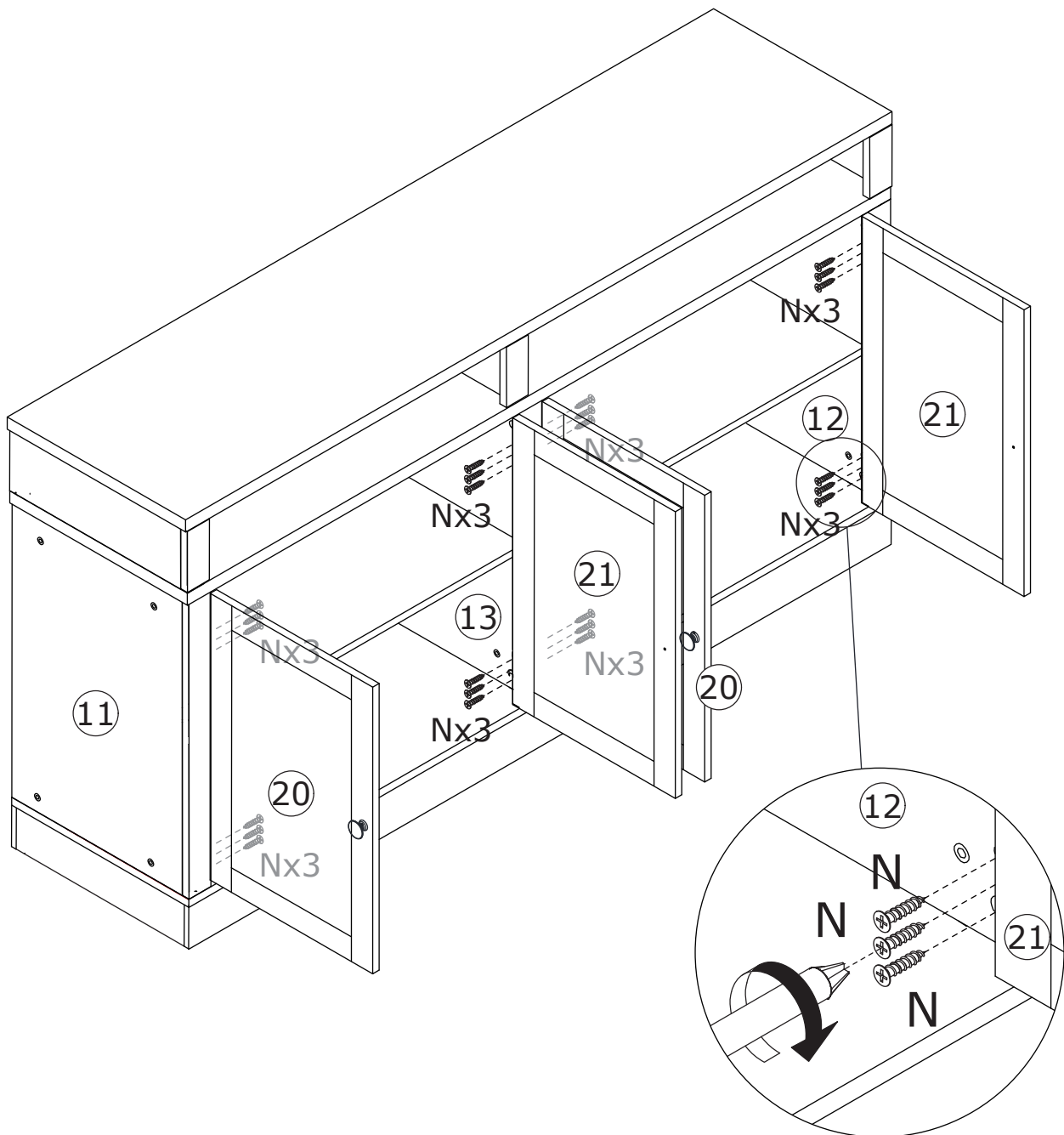

25

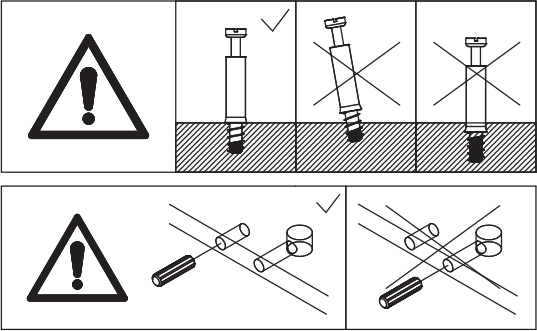
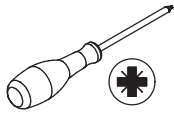
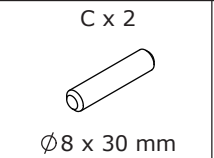
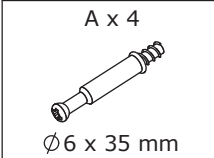

Screw eccentric rod (A) and insert wooden dowel (C) into plate 32 as shown.

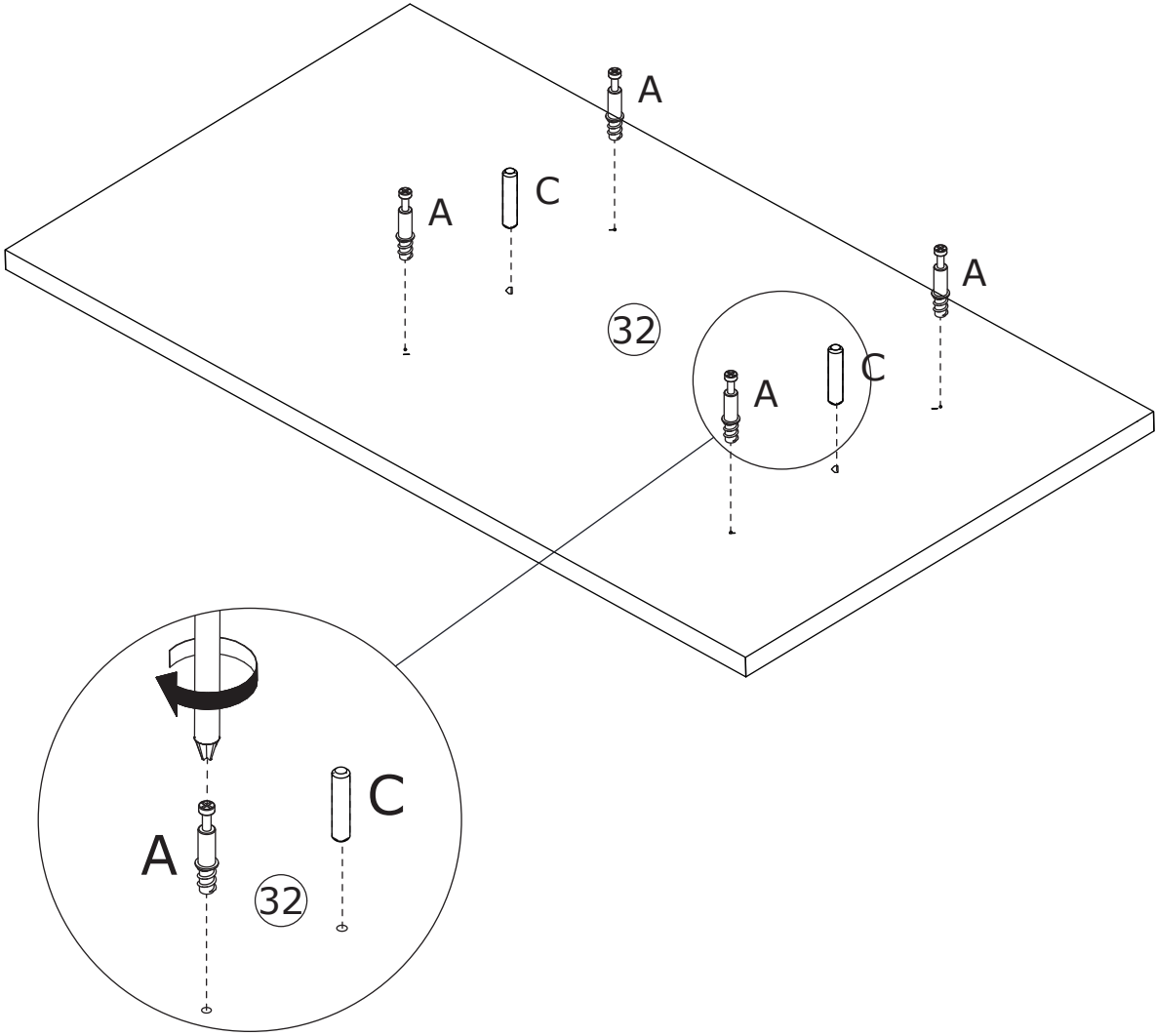

26

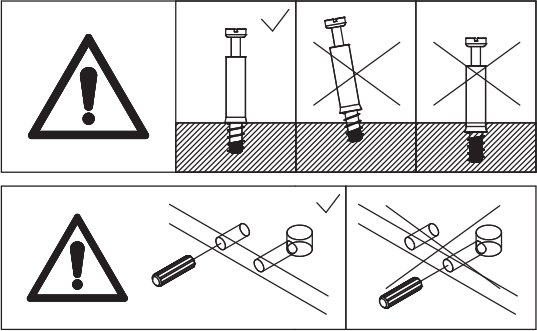
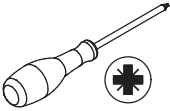
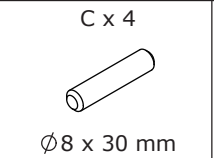
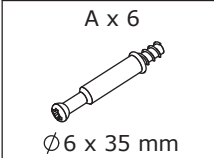

Screw eccentric rod (A) and insert wooden dowel (C) into plate 33 as shown.

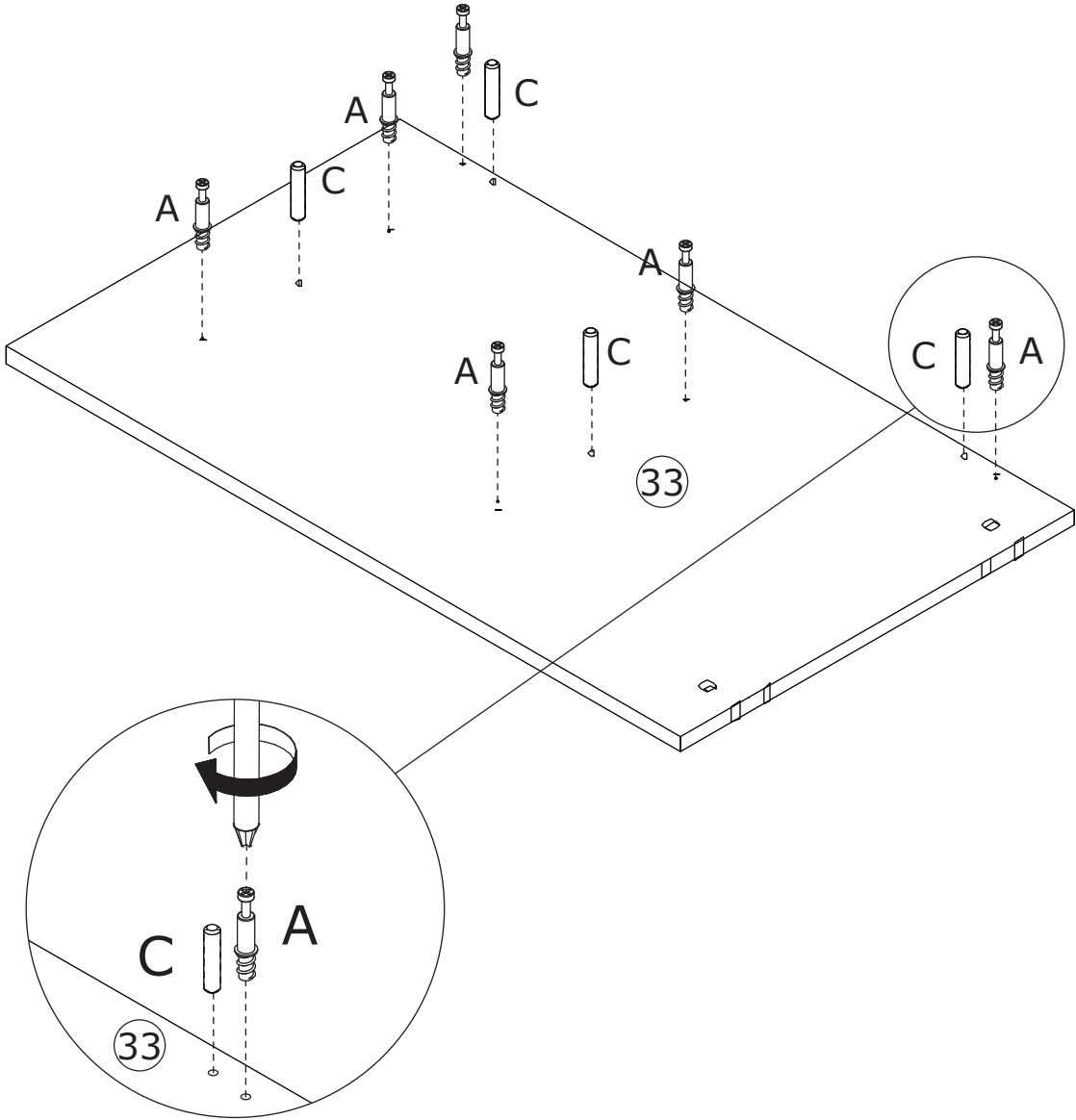

27

B x 4



Ø15 x 11 mm

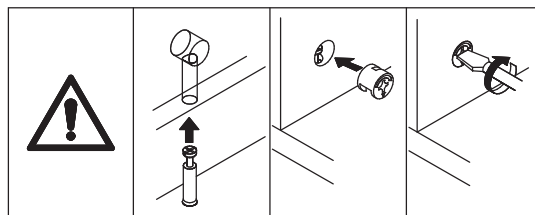
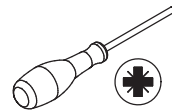

Connect plate 29 and 25 to plate 32, then turn cam lock (B) clockwise to tighten as shown.

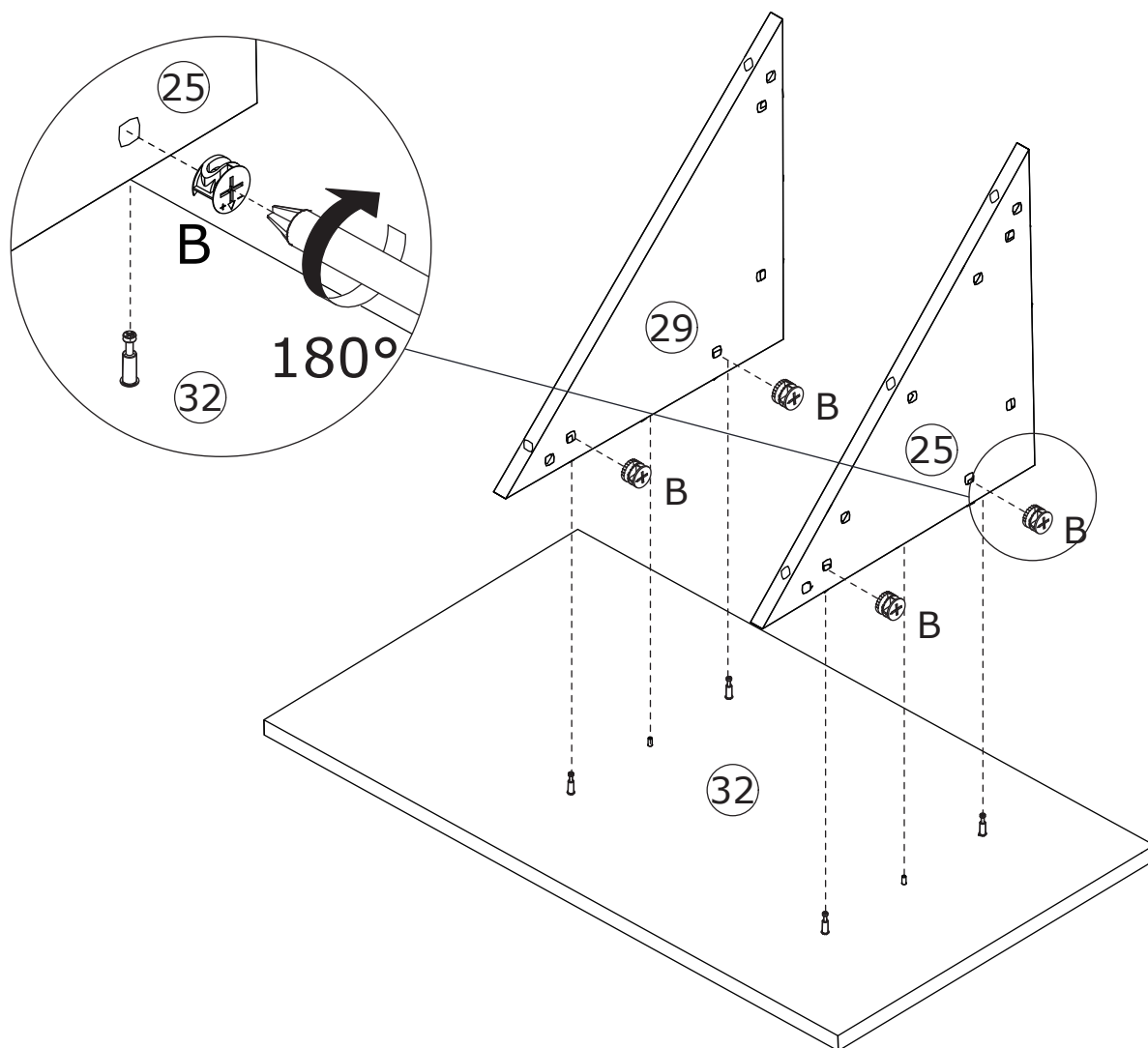

28

B x 6
Ø15 x 11 mm

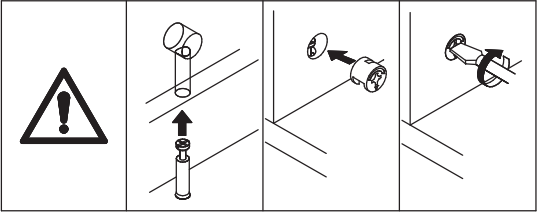
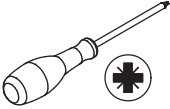

Connect plate 33 to plate 33, 29 and 25, then turn cam lock (B) clockwise to tighten as shown.

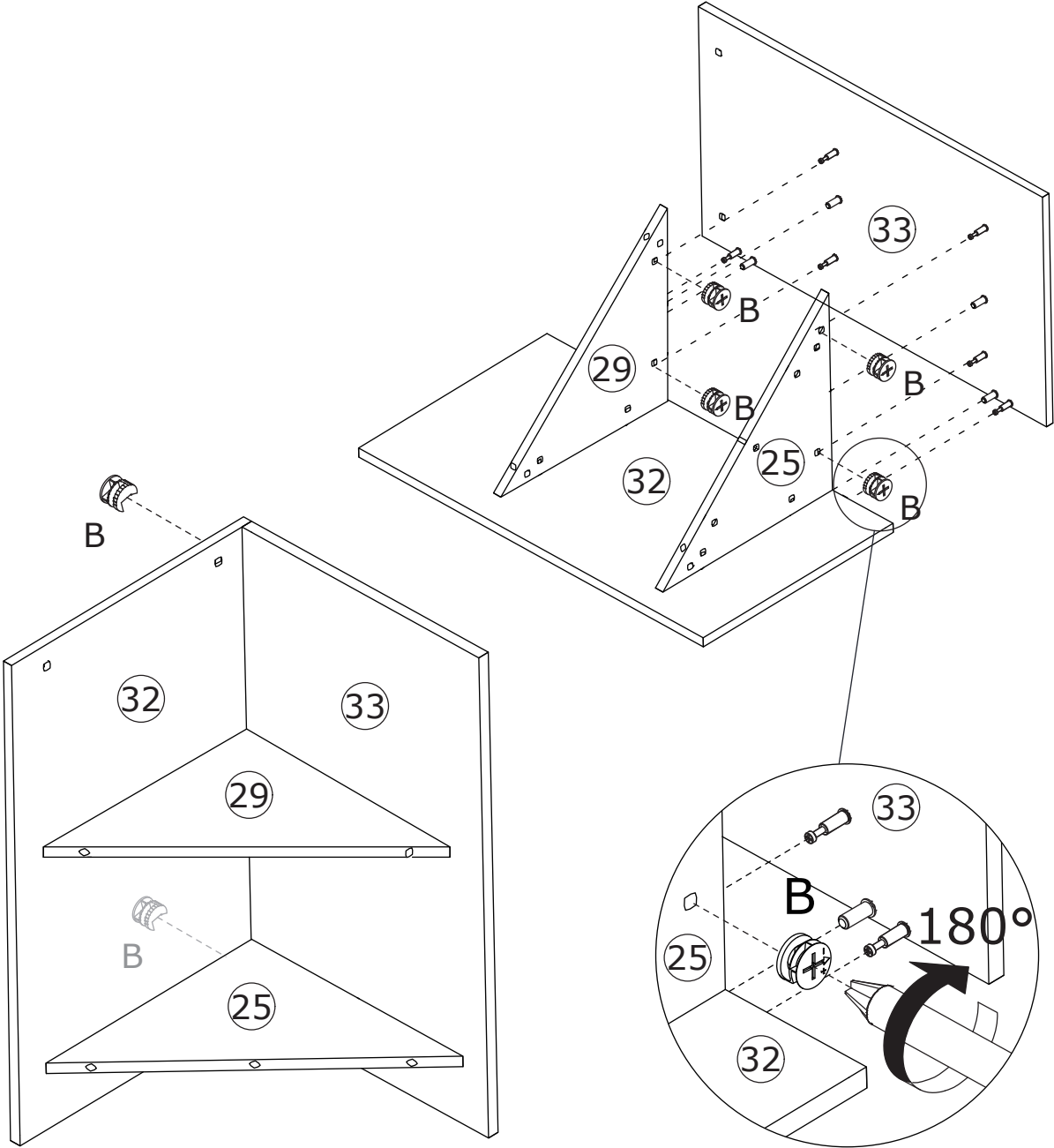

29

A x 8
Ø6 x 35 mm

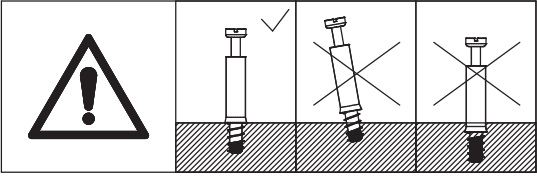
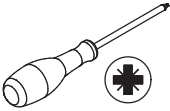

Screw eccentric rod (A) into plate 38 and 39 as shown.

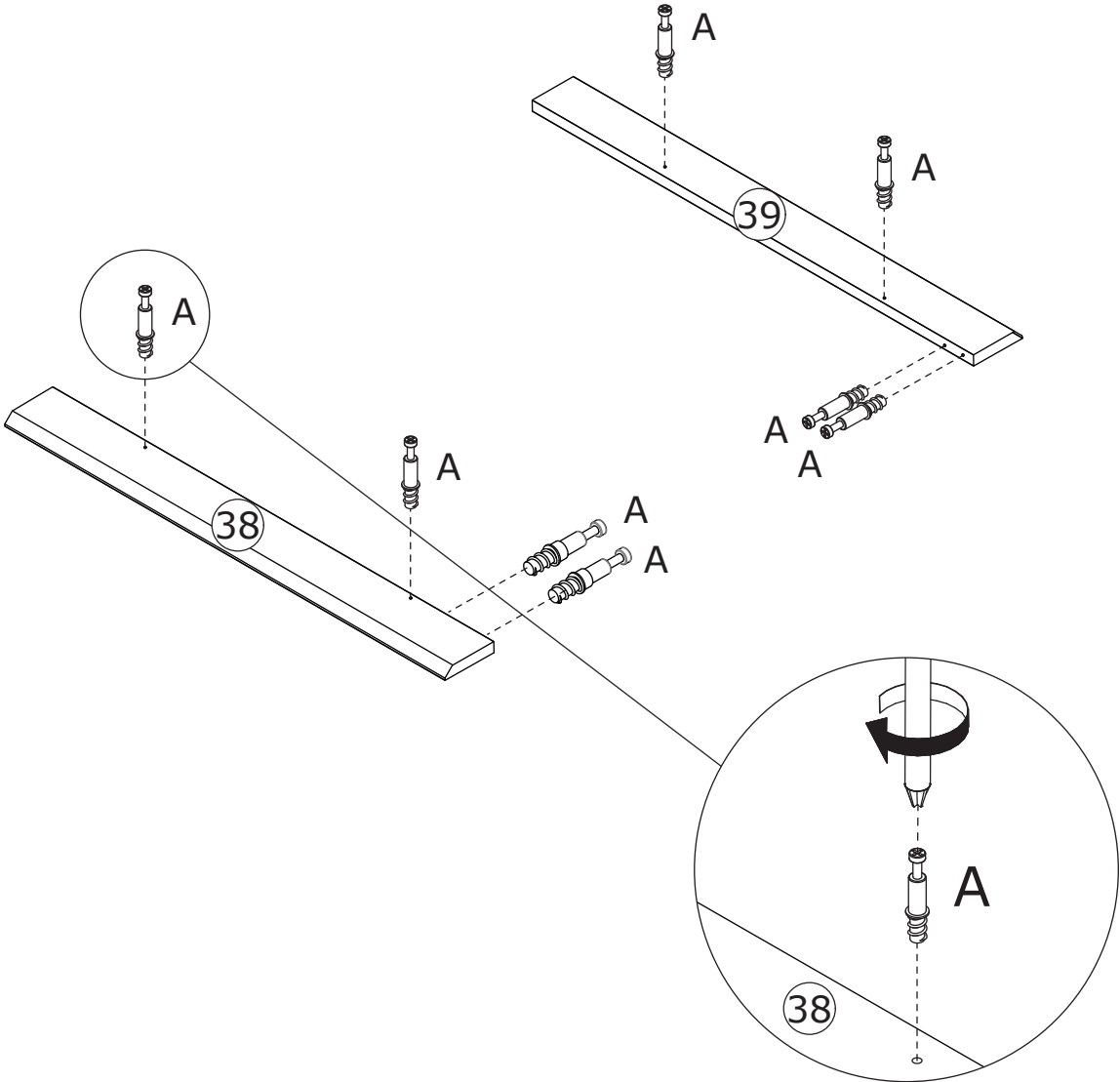

30

B x 4
Ø15 x 11 mm

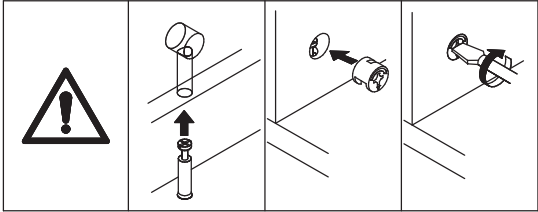
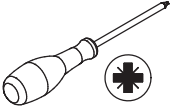

Connect plate 48 to plate 39 and 38, then turn cam lock (B) clockwise to tighten as shown.

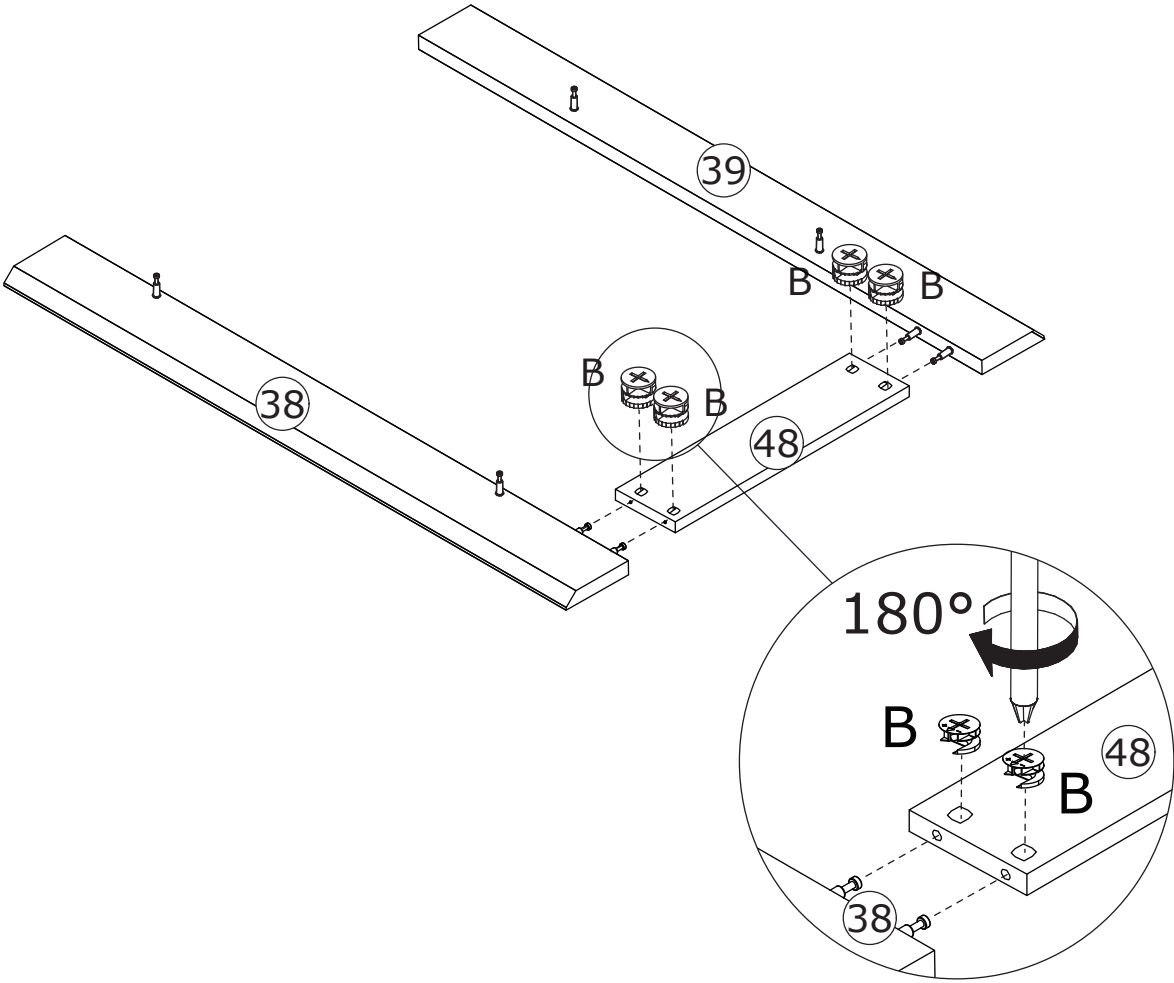

31



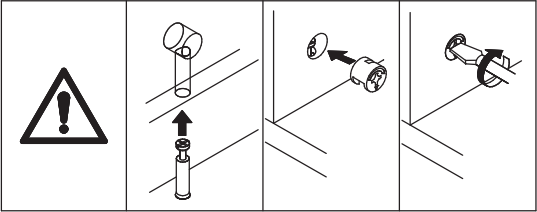
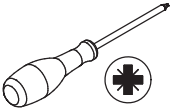

B x 4
Ø15 x 11 mm

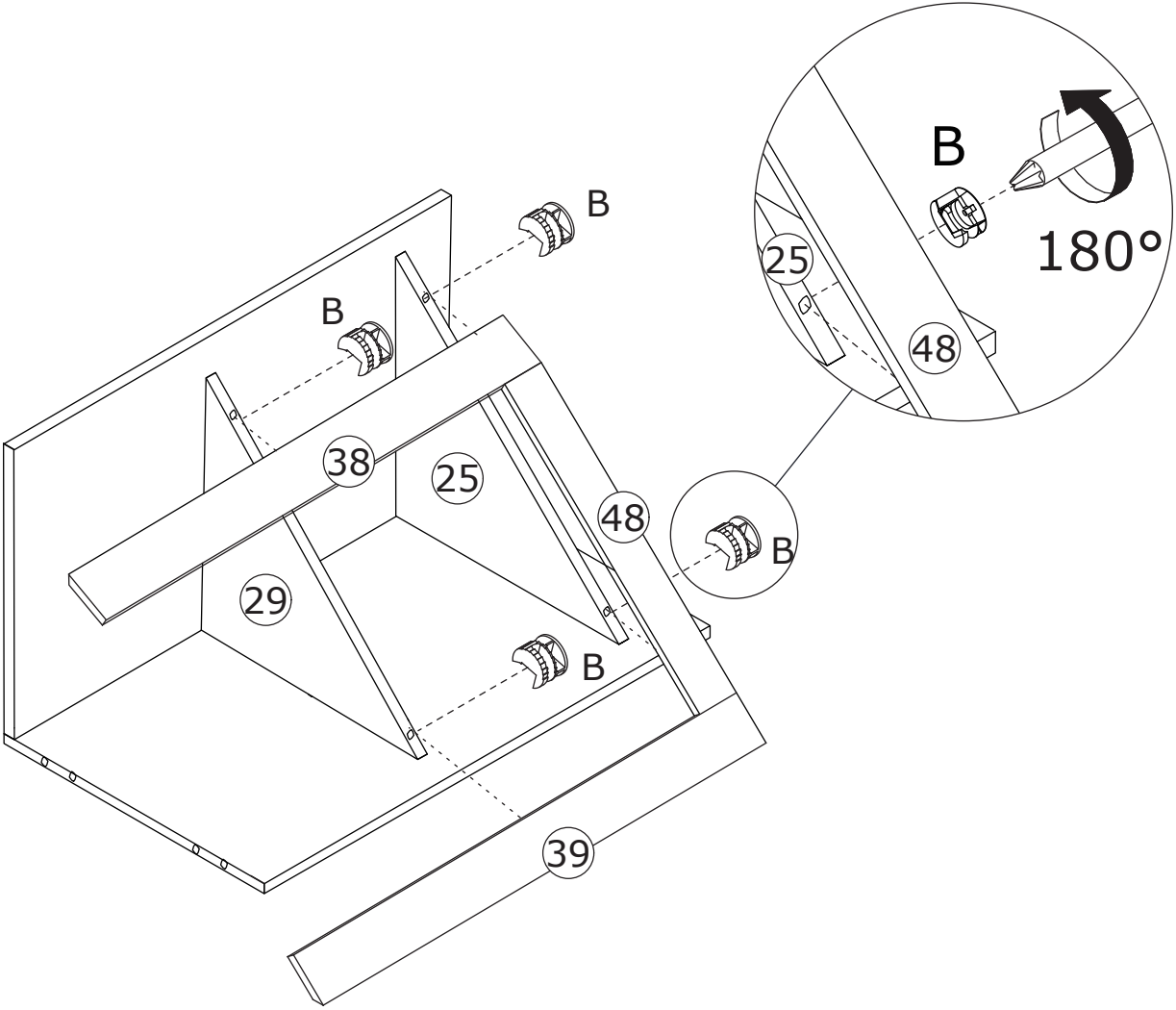

Connect plate 38, 39, and 48 to plate 29 and 25, then turn cam lock (B) clockwise to tighten as shown.

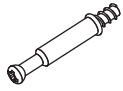

32

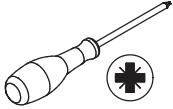
<p>A x 4</p>  <p>∅6 x 35 mm</p>	<p>C x 8</p>  <p>∅8 x 30 mm</p>	<p>D x 1</p>  <p></p>	<p>L x 2</p>  <p>∅3 x 14 mm</p>	
--	--	--	---	---

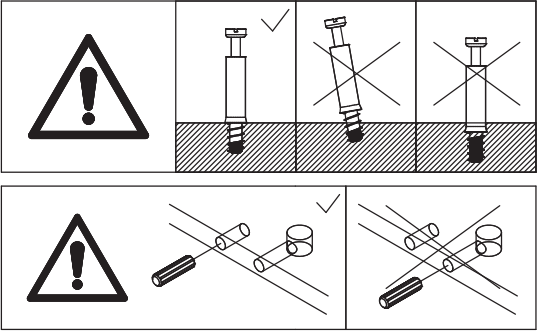

Screw eccentric rod (A) and insert wooden dowel (C) into plate 24.
Next, fix magnet (D) with screw (L) as shown.

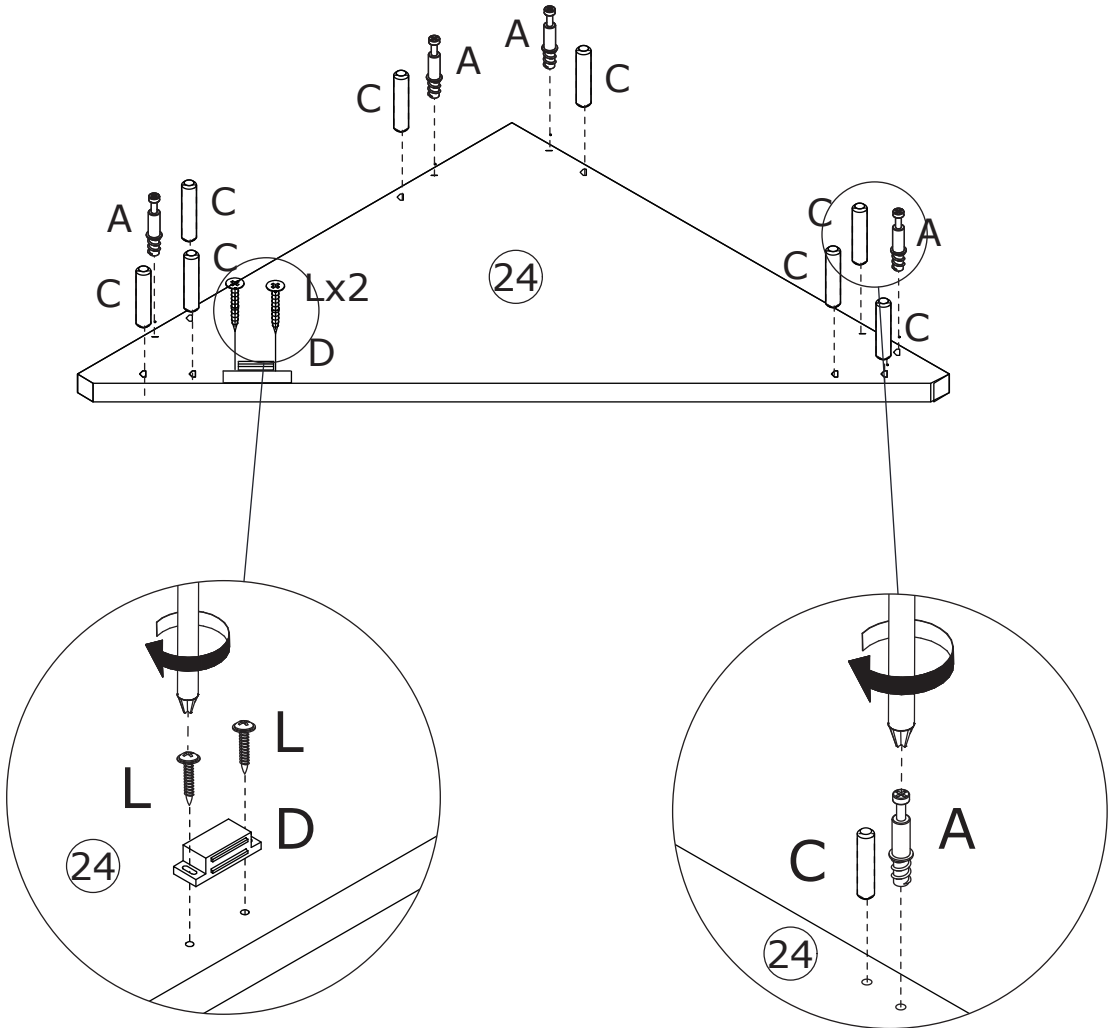

33

B x 4



Ø15 x 11 mm

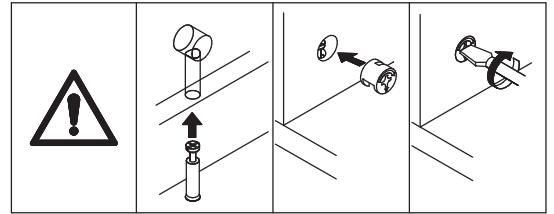
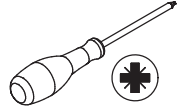

Connect plate 24 to plate 32 and 33, then turn cam lock (B) clockwise to tighten as shown.

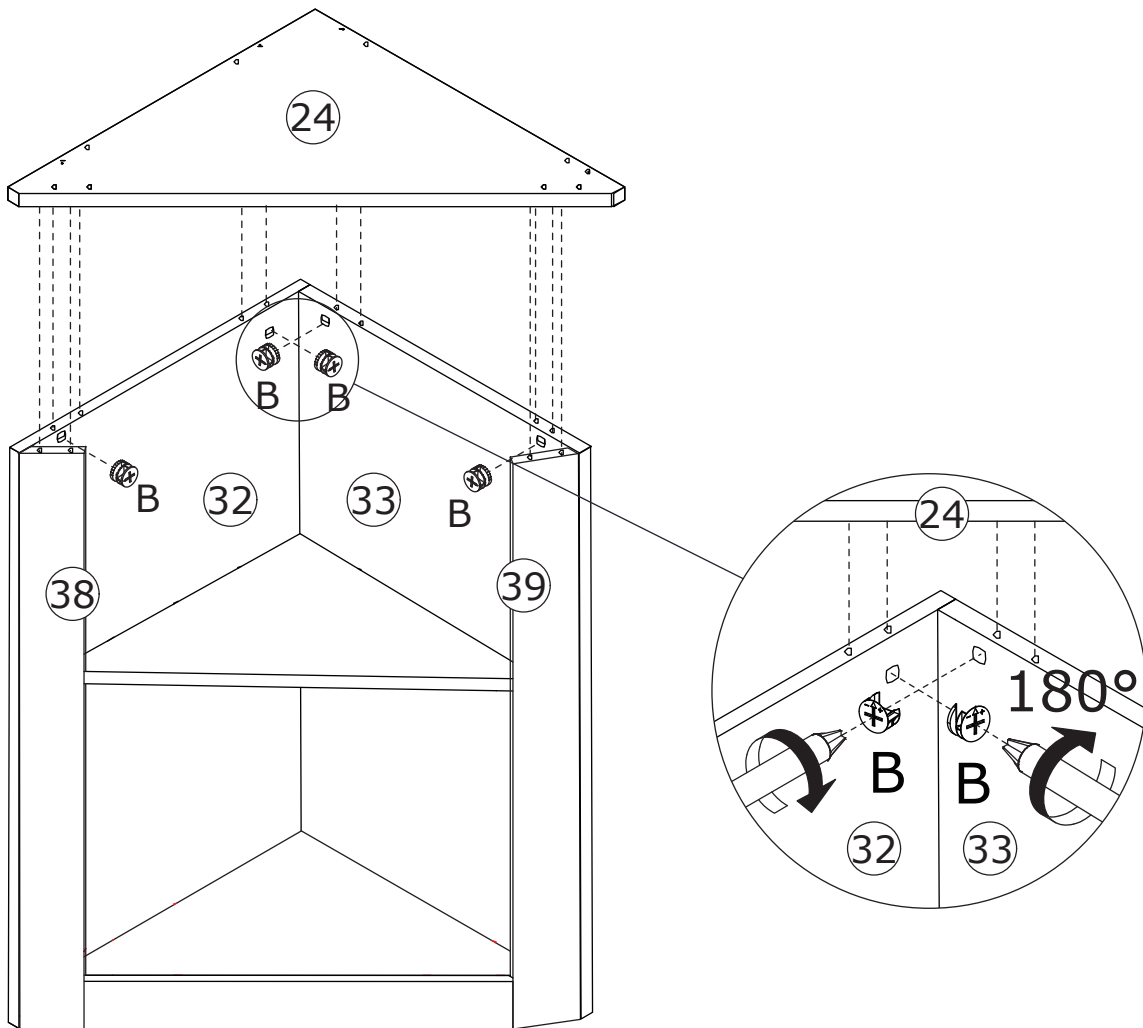

34

<p>A x 4</p>  <p>Ø6 x 35 mm</p>	<p>C x 8</p>  <p>Ø8 x 30 mm</p>	
--	--	---

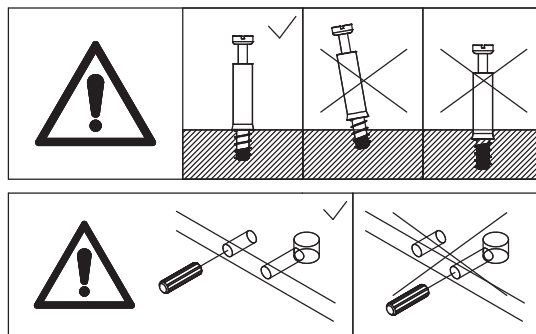

Screw eccentric rod (A) and insert wooden dowel (C) into plate 24.

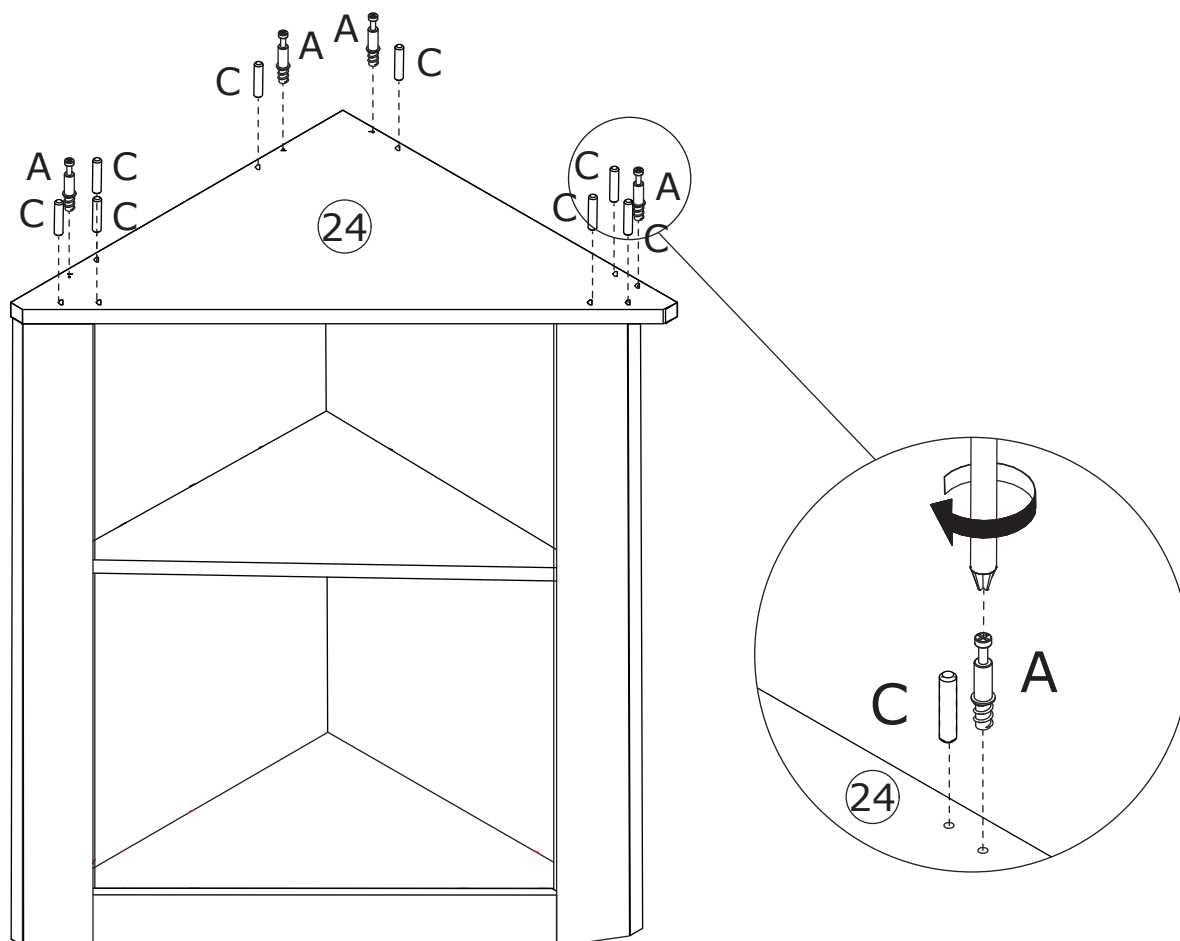

35

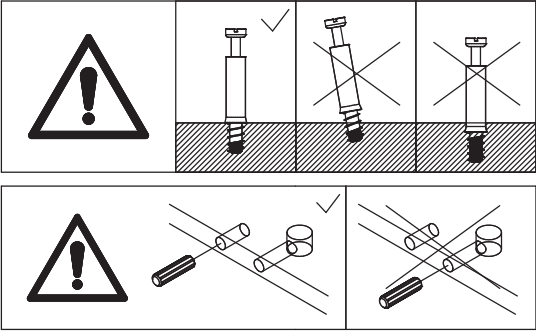
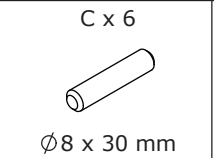
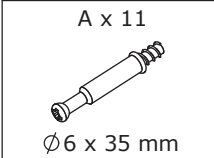

Screw eccentric rod (A) and insert wooden dowel (C) into plate 37 and 30 as shown.

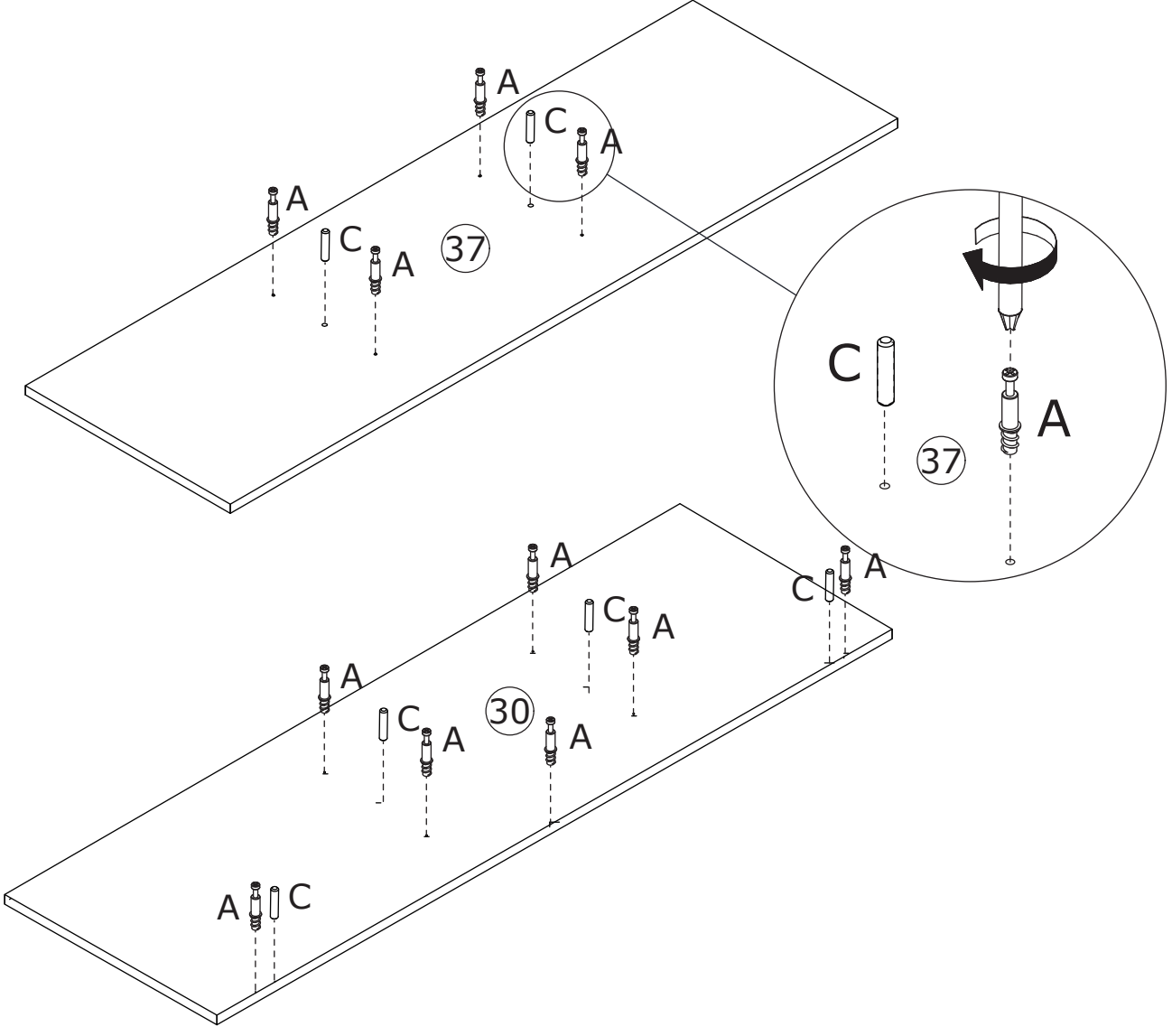

36

B x 4
Ø15 x 11 mm

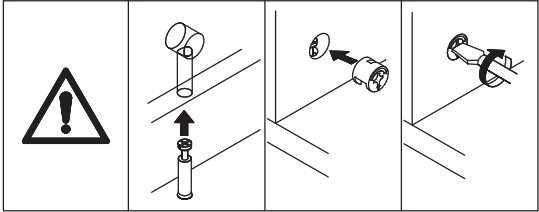
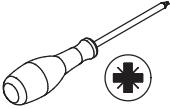

Connect plate 29 to plate 37, then turn cam lock (B) clockwise to tighten as shown.

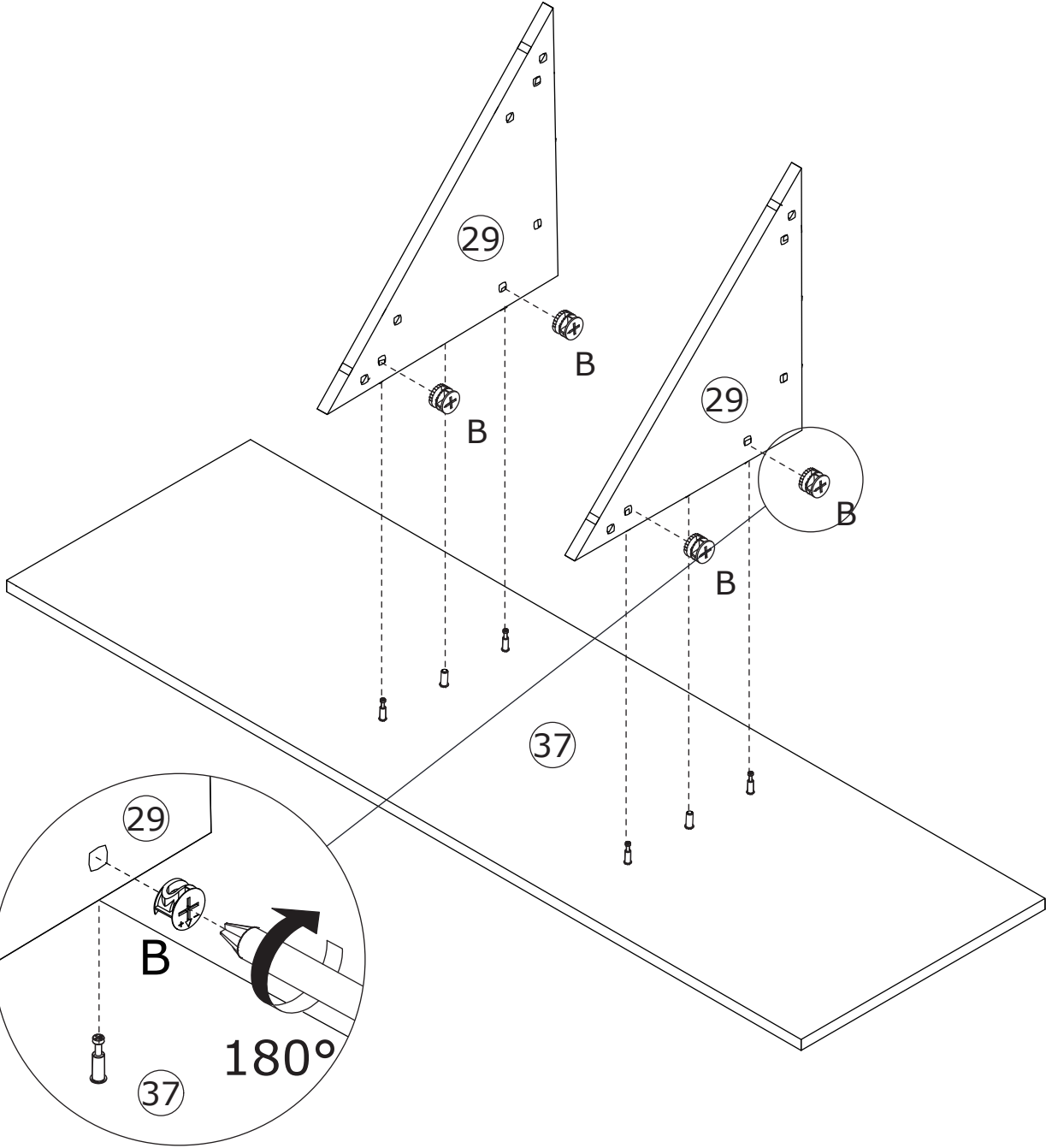

37

B x 7



Ø15 x 11 mm

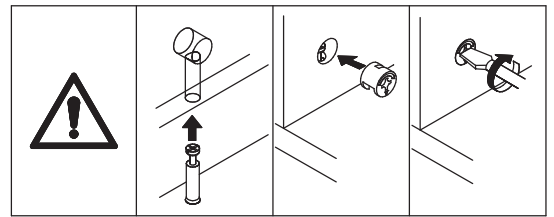
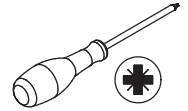

Connect plate 30 to plate 37 and 29, then turn cam lock (B) clockwise to tighten as shown.

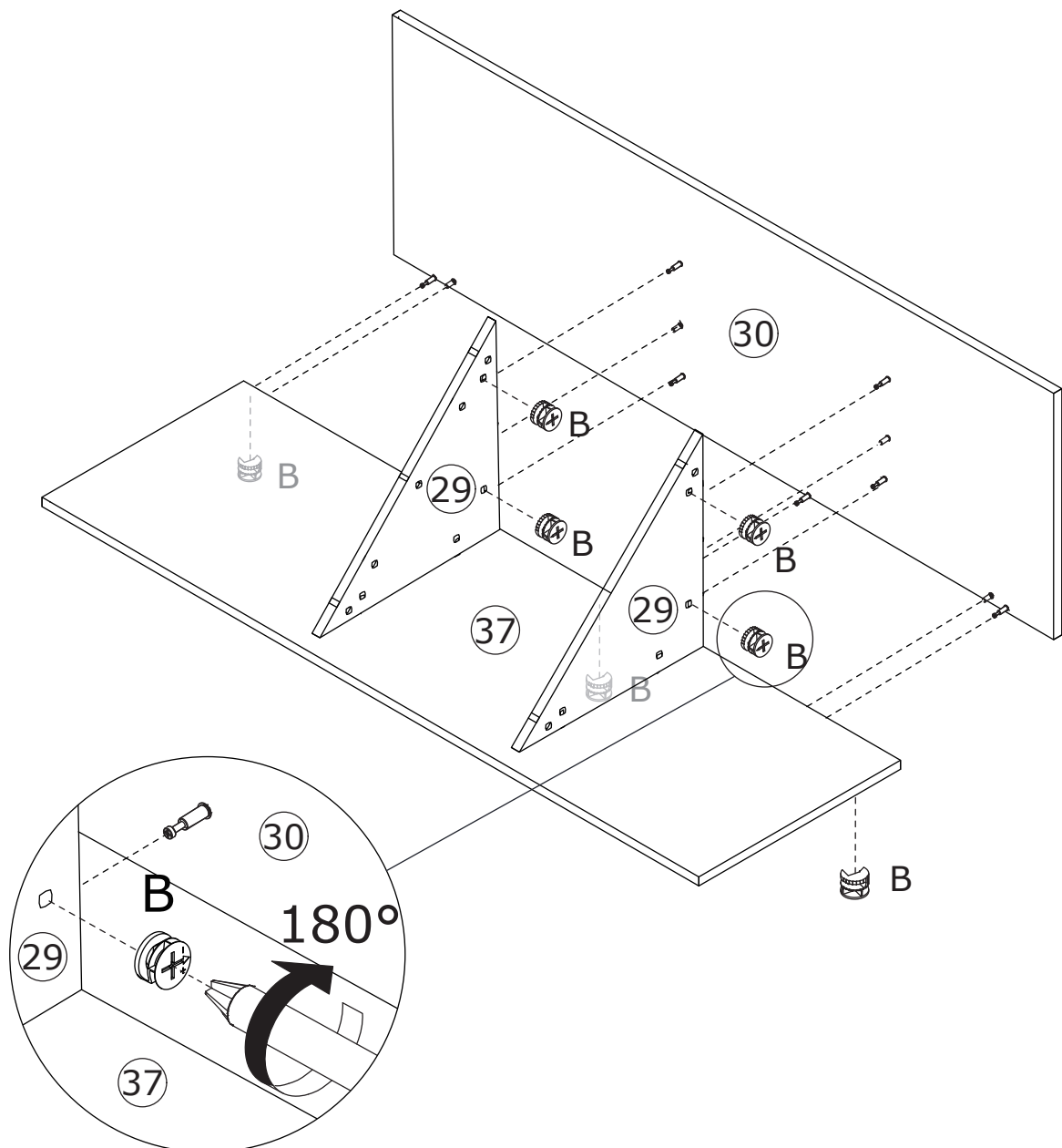

38

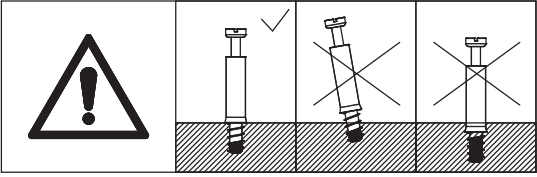
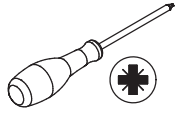
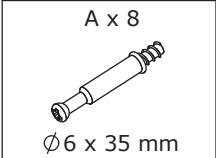

Screw eccentric rod (A) into plate 40 and 41 as shown.

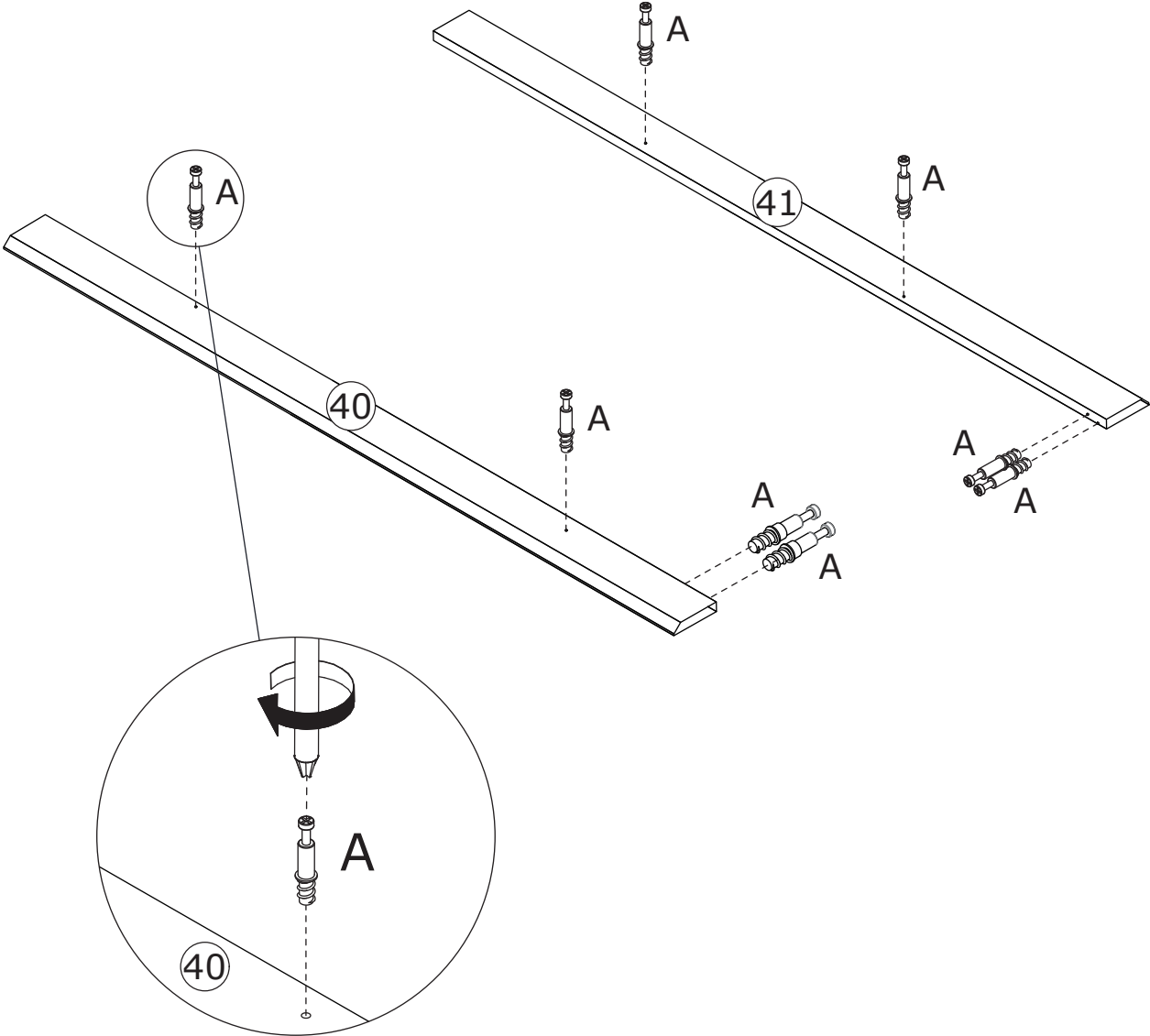

39

B x 4



Ø15 x 11 mm

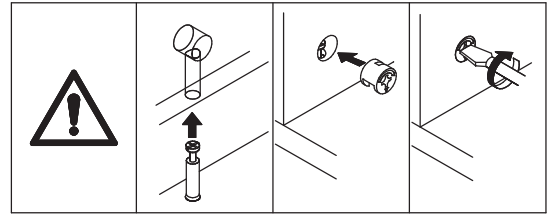
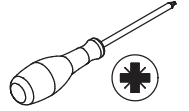

Connect plate 49 to plate 40 and 41, then turn cam lock (B) clockwise to tighten as shown.

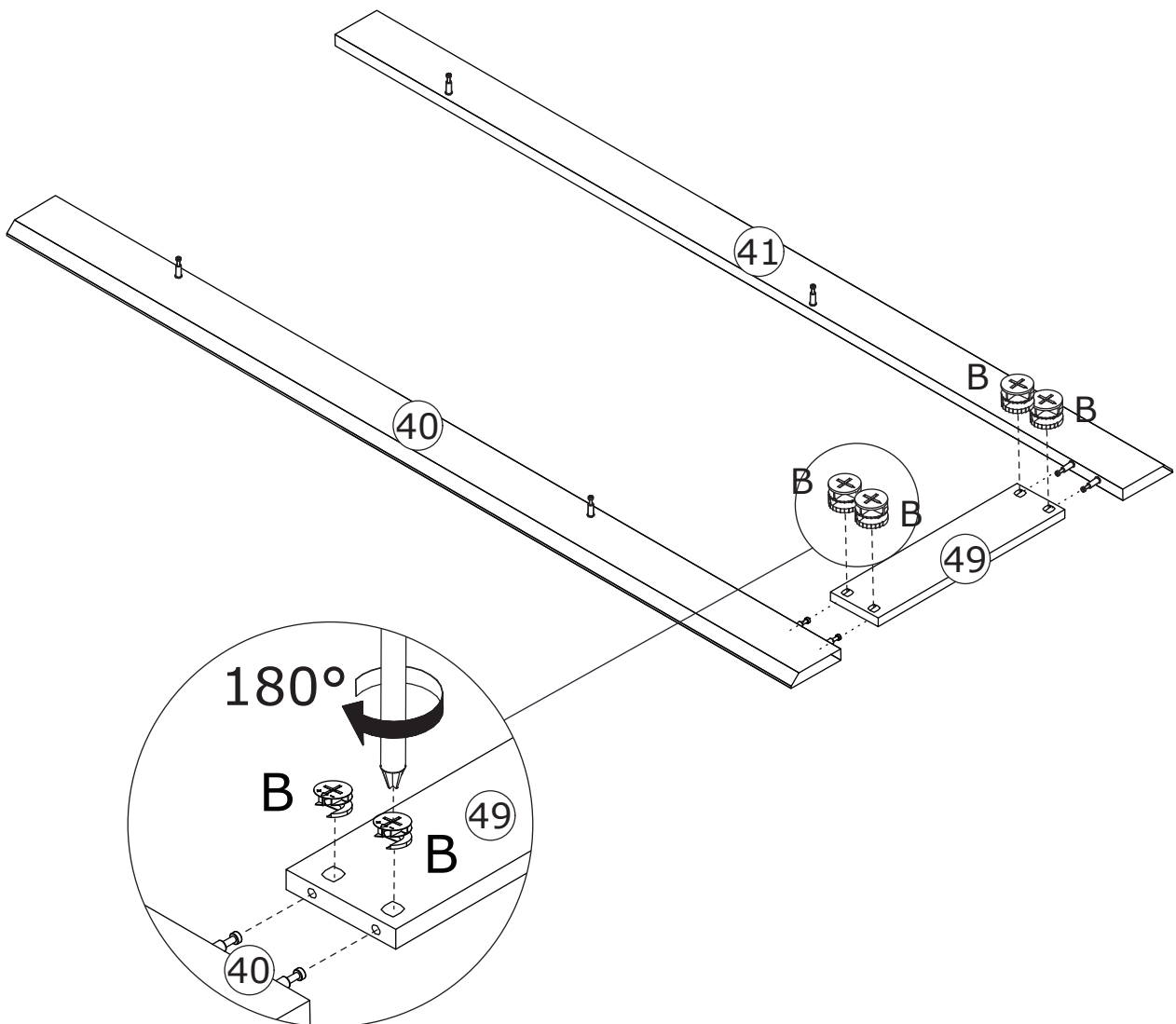

40

B x 4
Ø15 x 11 mm

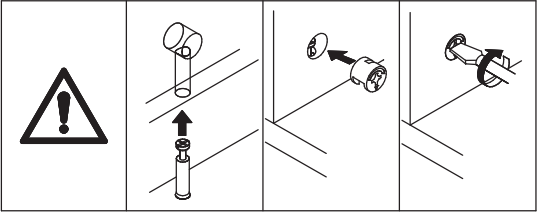
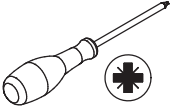

Connect plate 40 and 41 to plate 29, then turn cam lock (B) clockwise to tighten as shown.

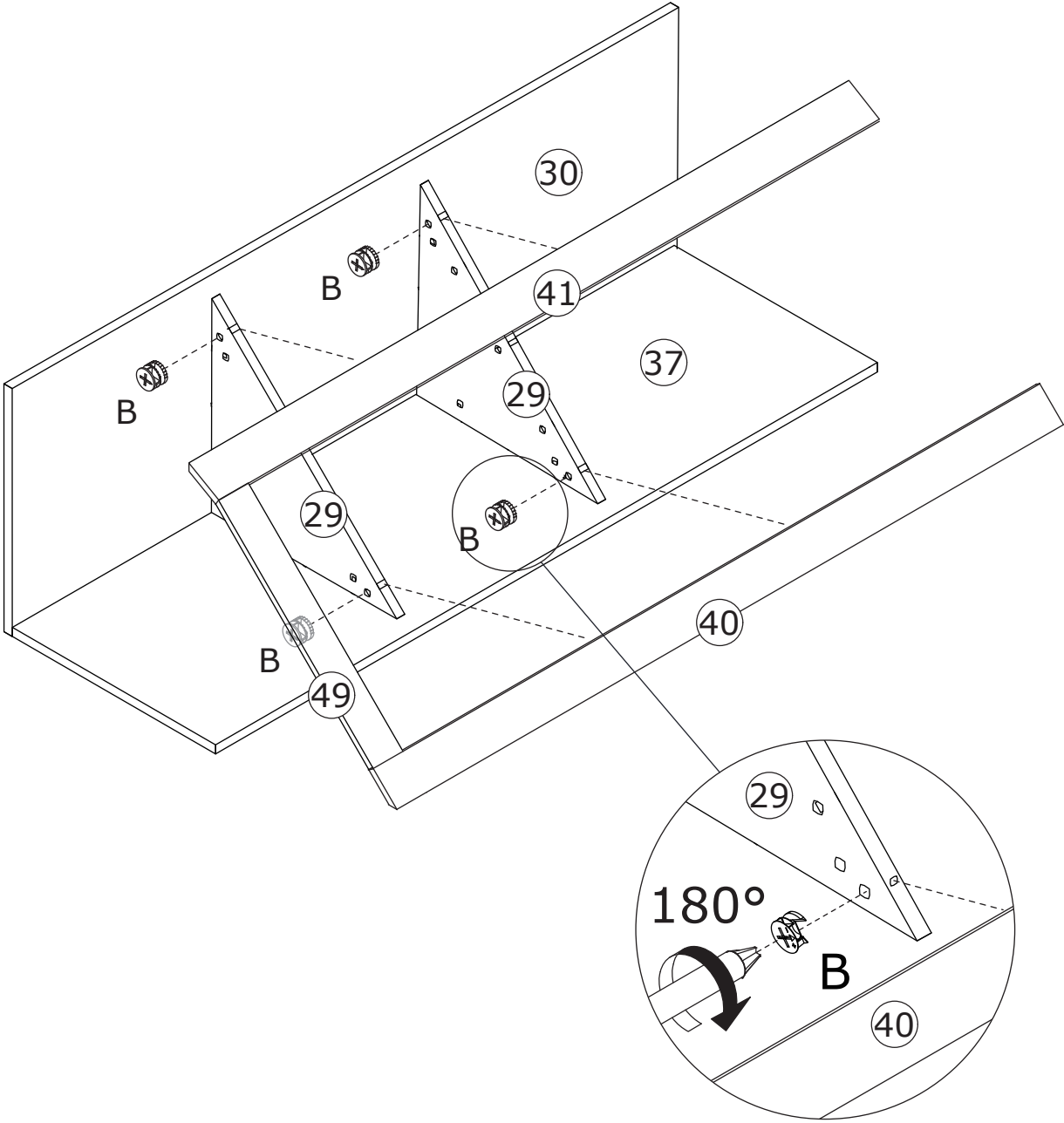

41

B x 4
Ø15 x 11 mm

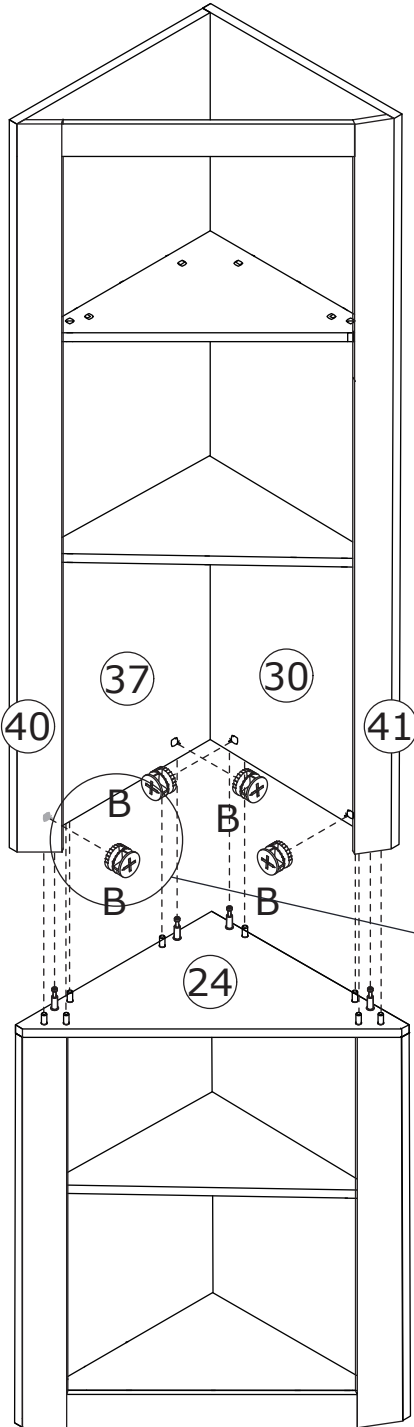
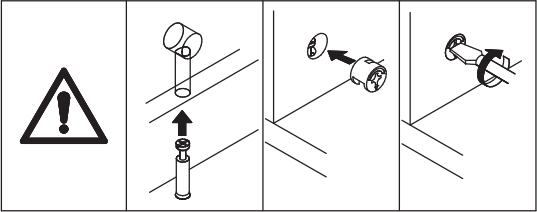
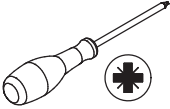

Connect the component to plate 24, then turn cam lock (B) clockwise to tighten as shown.

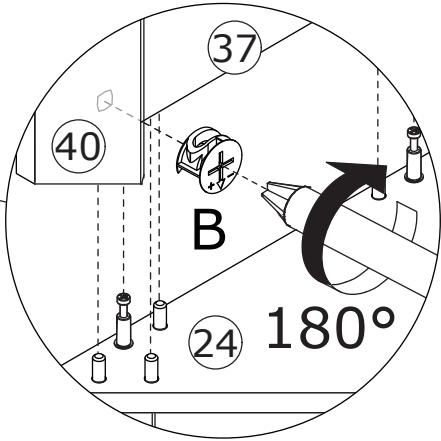

42

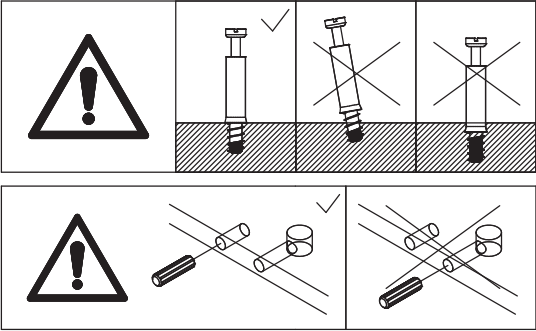
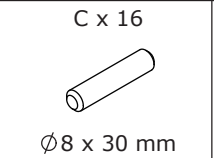
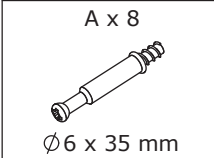

Screw eccentric rod (A) and insert wooden dowel (C) into plate 50 as shown.

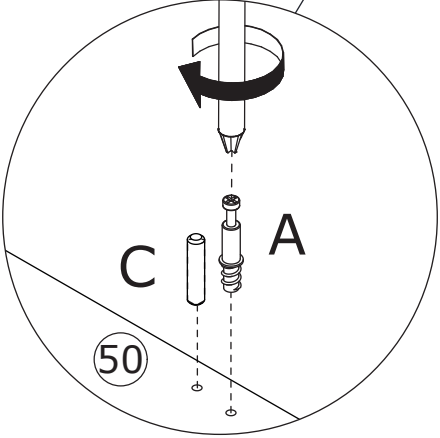
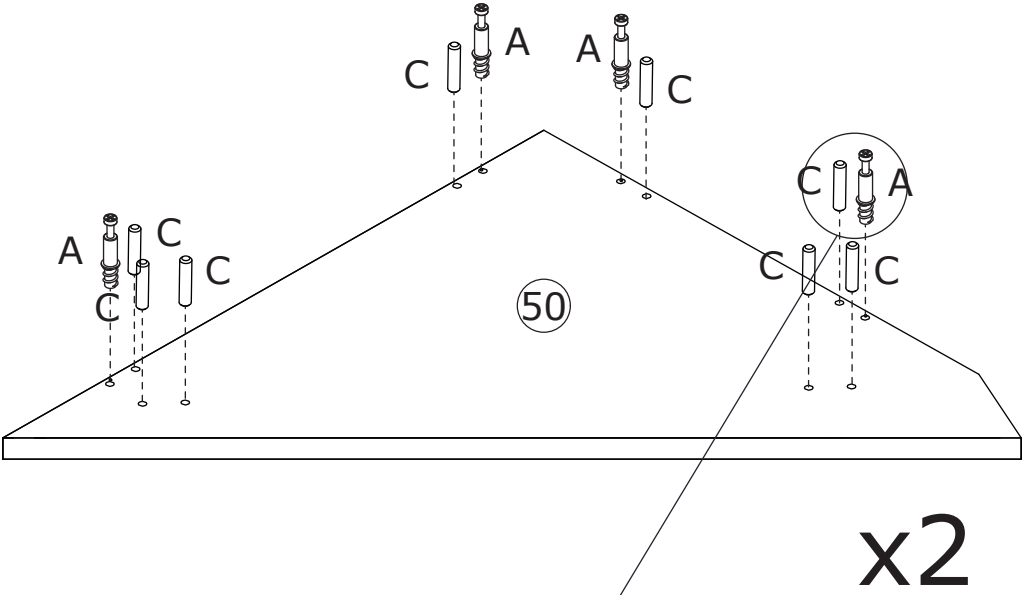

43

B x 4



Ø15 x 11 mm

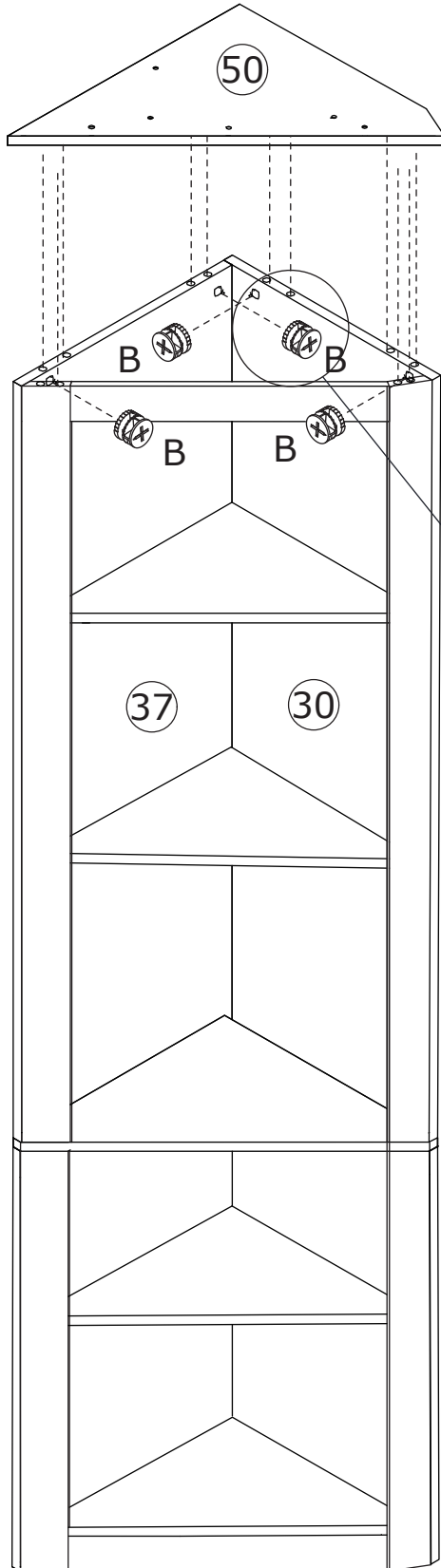
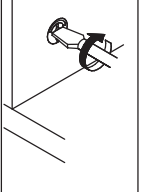
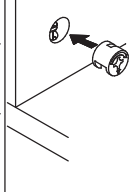
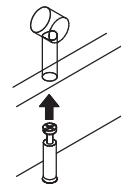
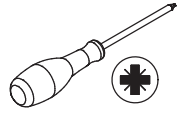

Connect plate 50 to the top, then turn cam lock (B) clockwise to tighten as shown.

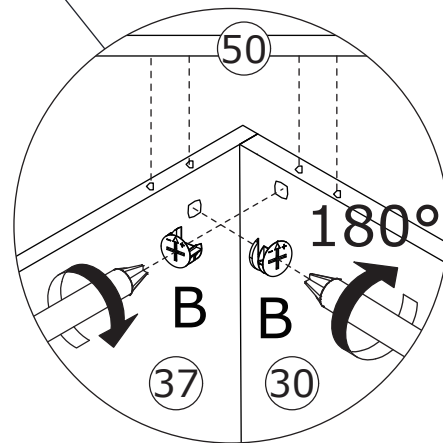

44

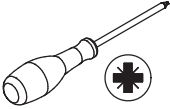
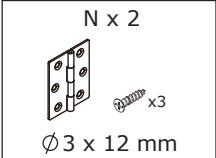

First, use screws to fix hinge (N) to plate 46 as shown.

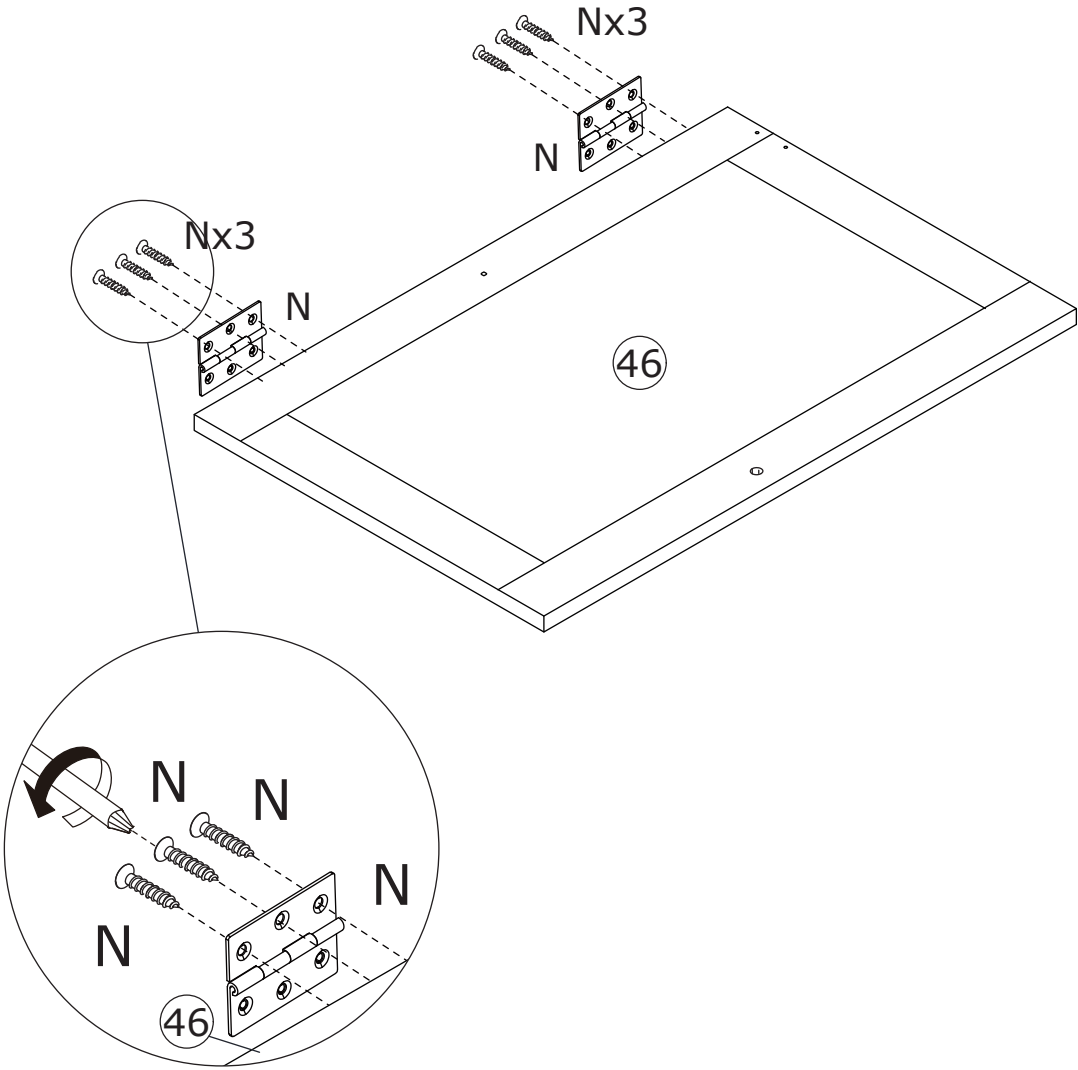

45

E x 2



Ø3 x 12 mm

F x 1



R x 1



Ø4 x 22 mm

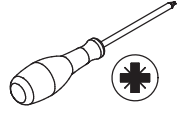

Fix part (F) to plate 46 using screws (E), then fix knob (R) as shown.

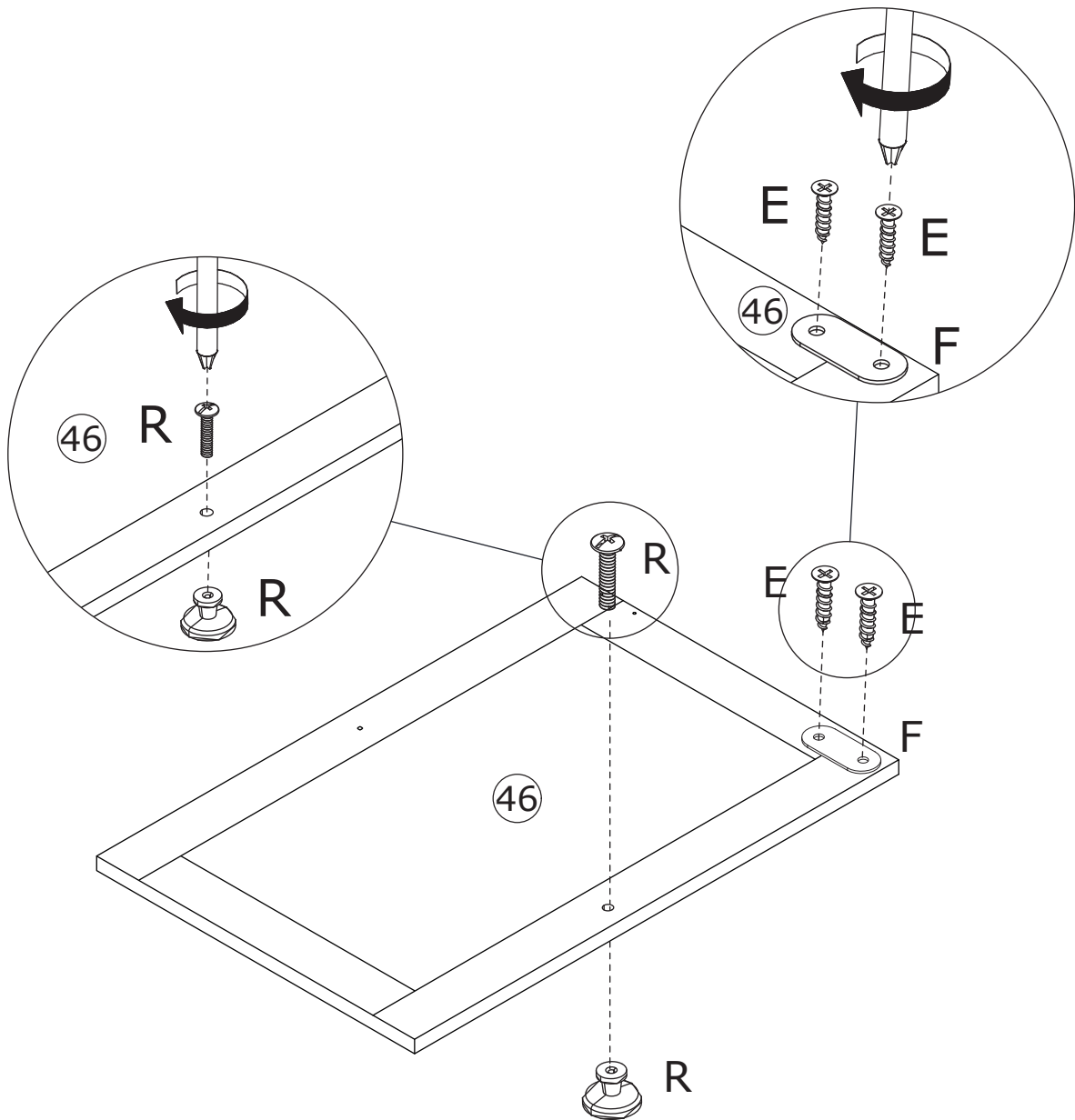

46

N x 6



Ø3 x 12 mm

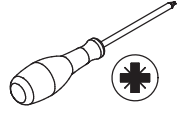

Use screw (N) to secure the installed hinges to plate 32 as shown.

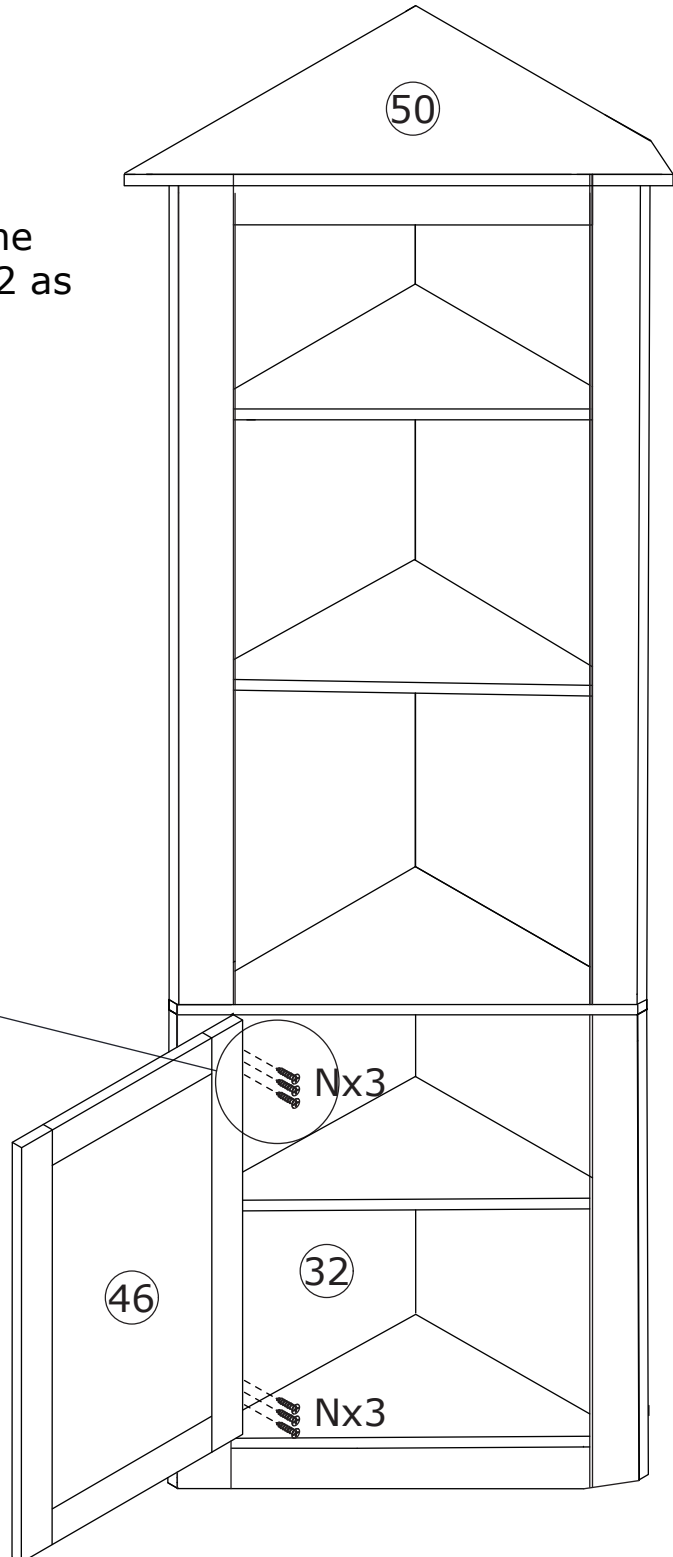
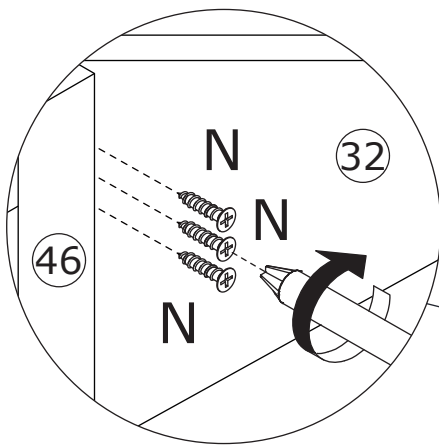

47

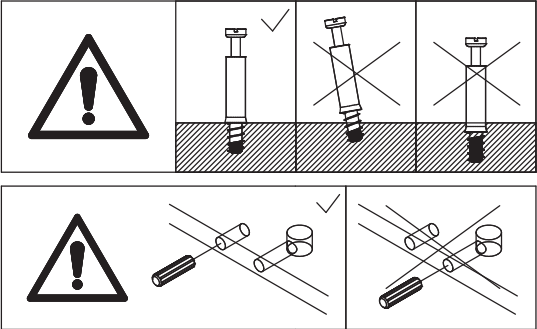
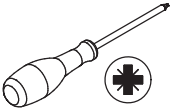
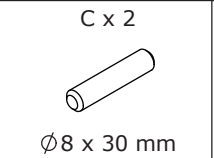
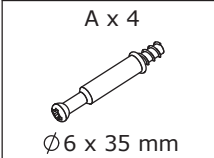

Screw eccentric rod (A) and insert wooden dowel (C) into plate 35 as shown.

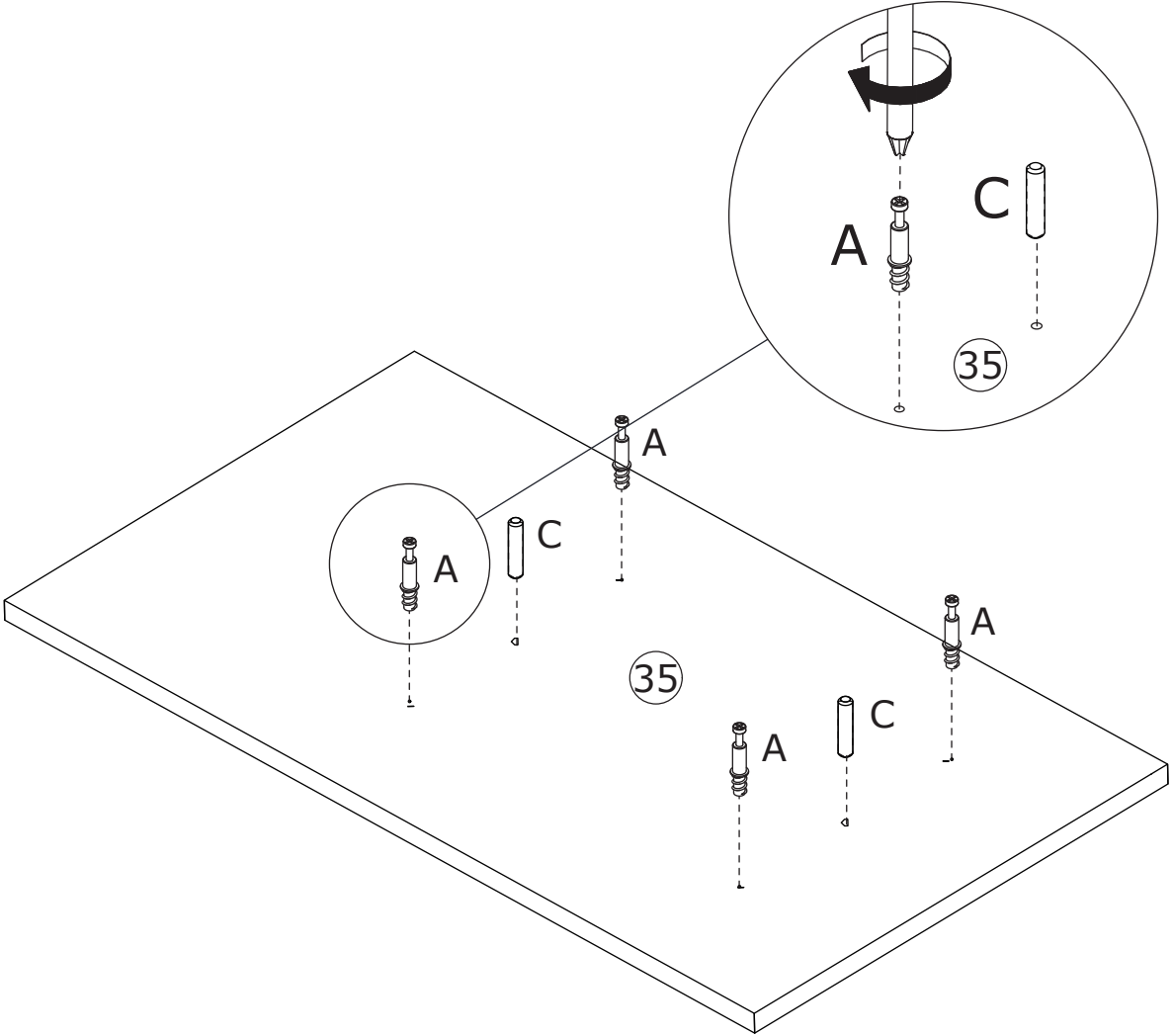

48

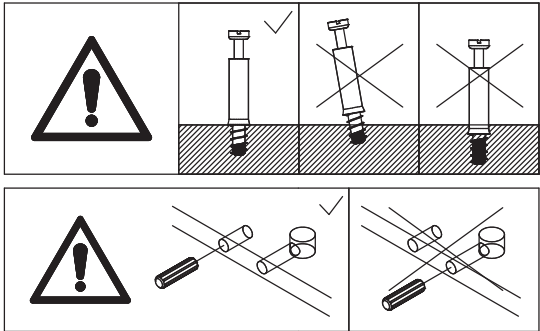
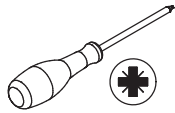
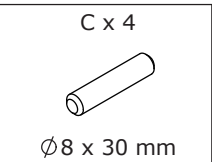
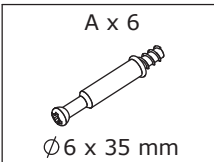

Screw eccentric rod (A) and insert wooden dowel (C) into plate 34 as shown.

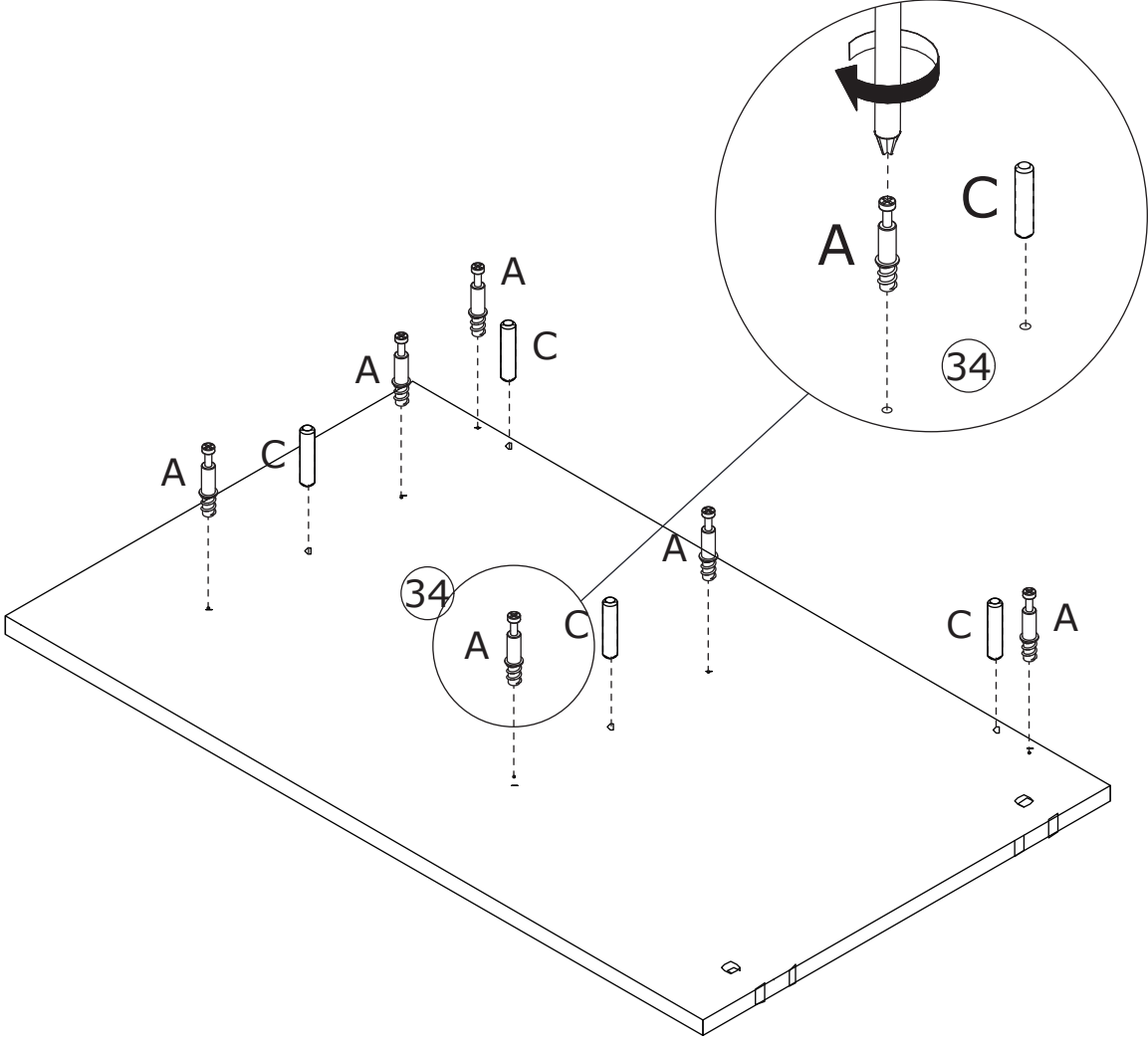

49

B x 4
Ø15 x 11 mm

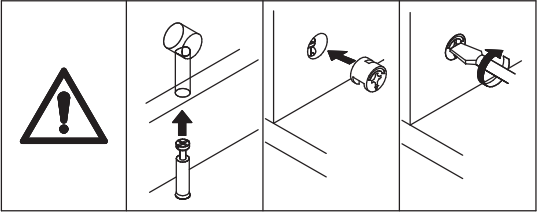
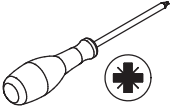

Connect plate 27 and 28 to plate 35, then turn cam lock (B) clockwise to tighten as shown.

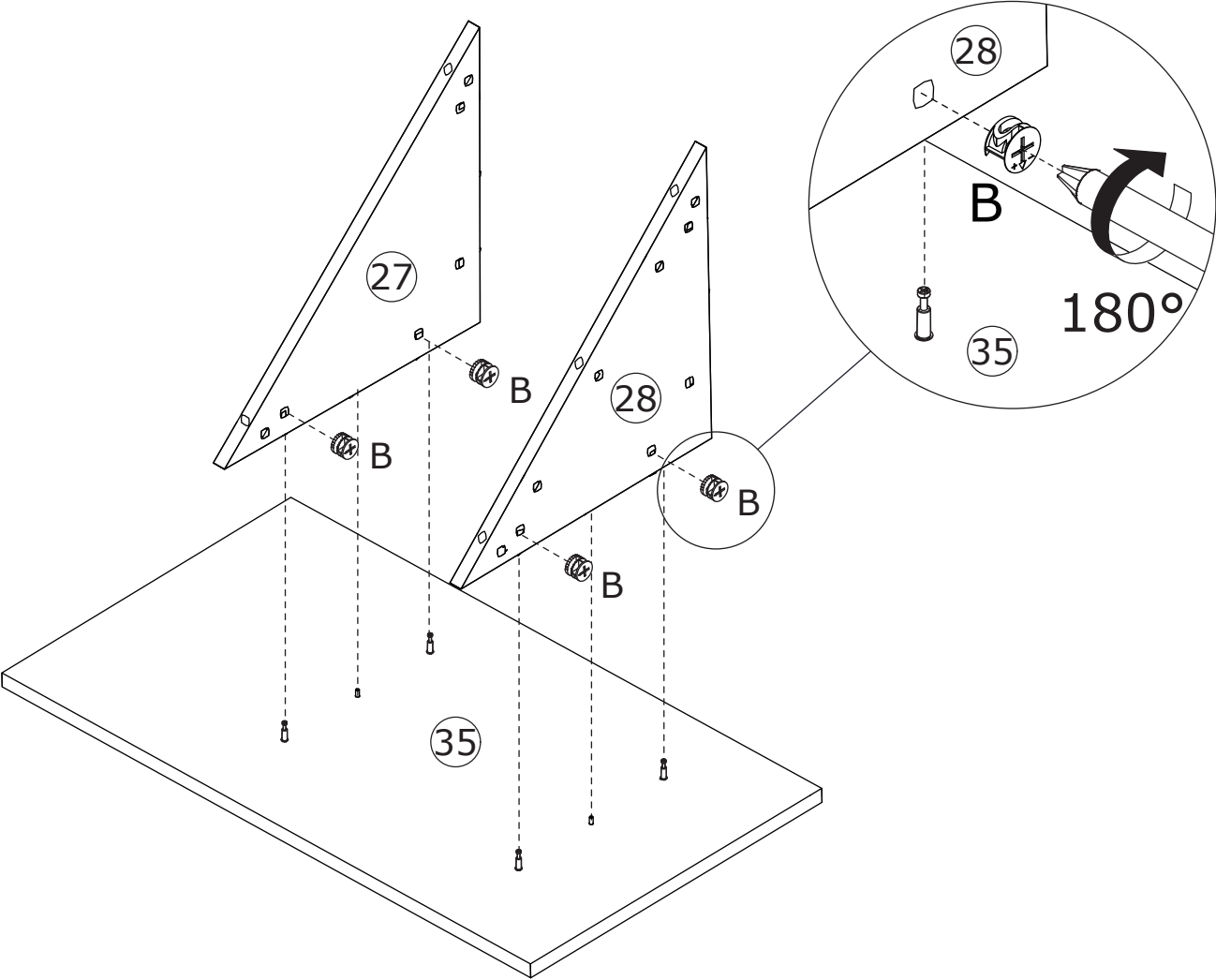

50

B x 6
Ø15 x 11 mm

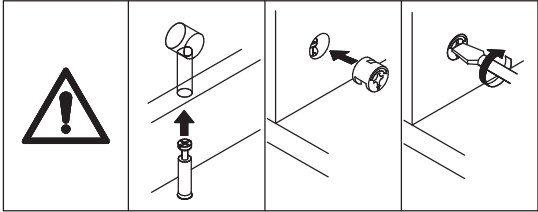
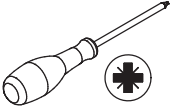

Connect plate 34 to plate 27, 28, and 35, then turn cam lock (B) clockwise to tighten as shown.

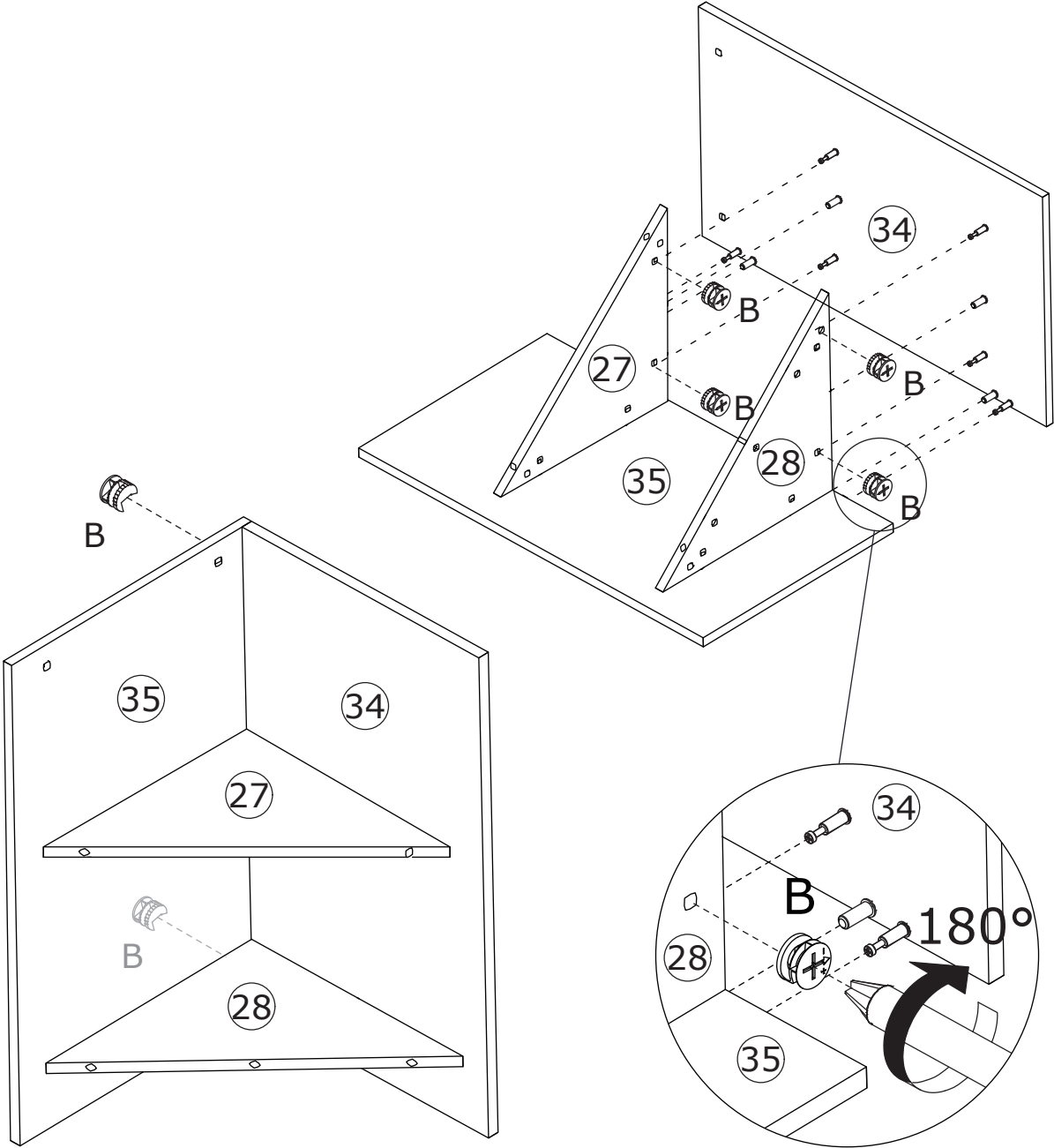

51

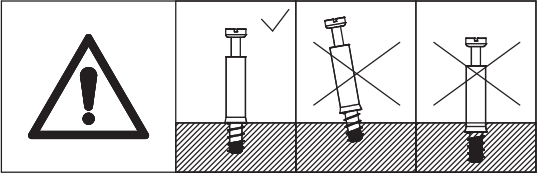
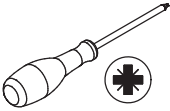
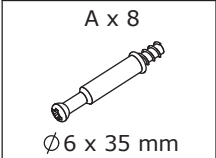

Screw eccentric rod (A) into plate 44 and 45 as shown.

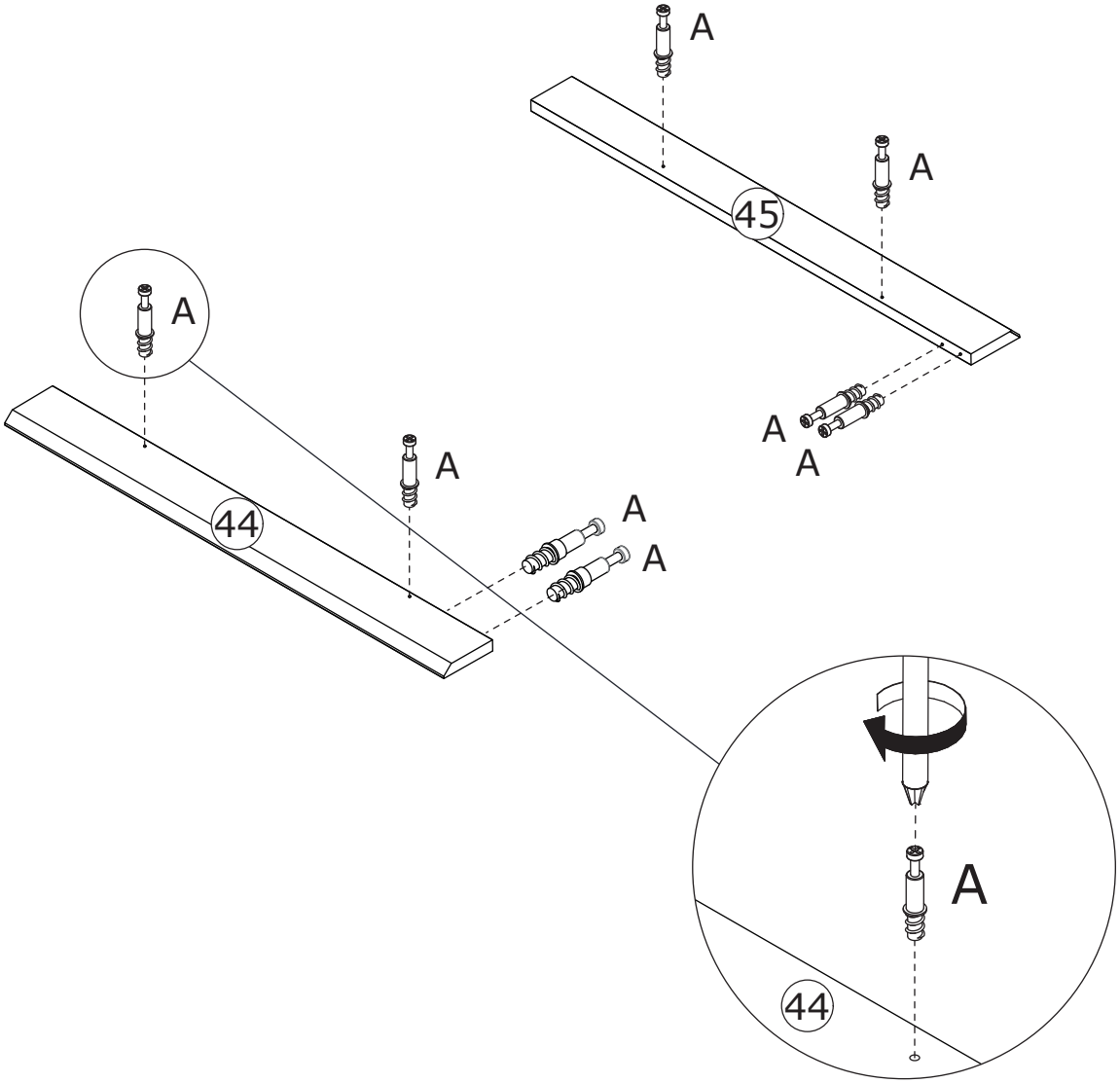

52

B x 4



Ø15 x 11 mm

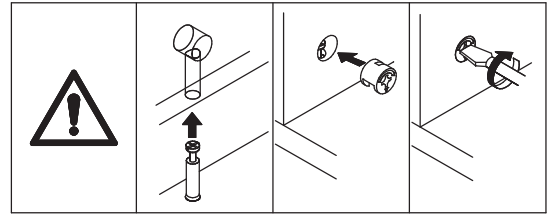
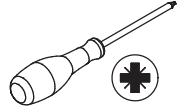

Connect plate 48 to plate 45 and 44, then turn cam lock (B) clockwise to tighten as shown.

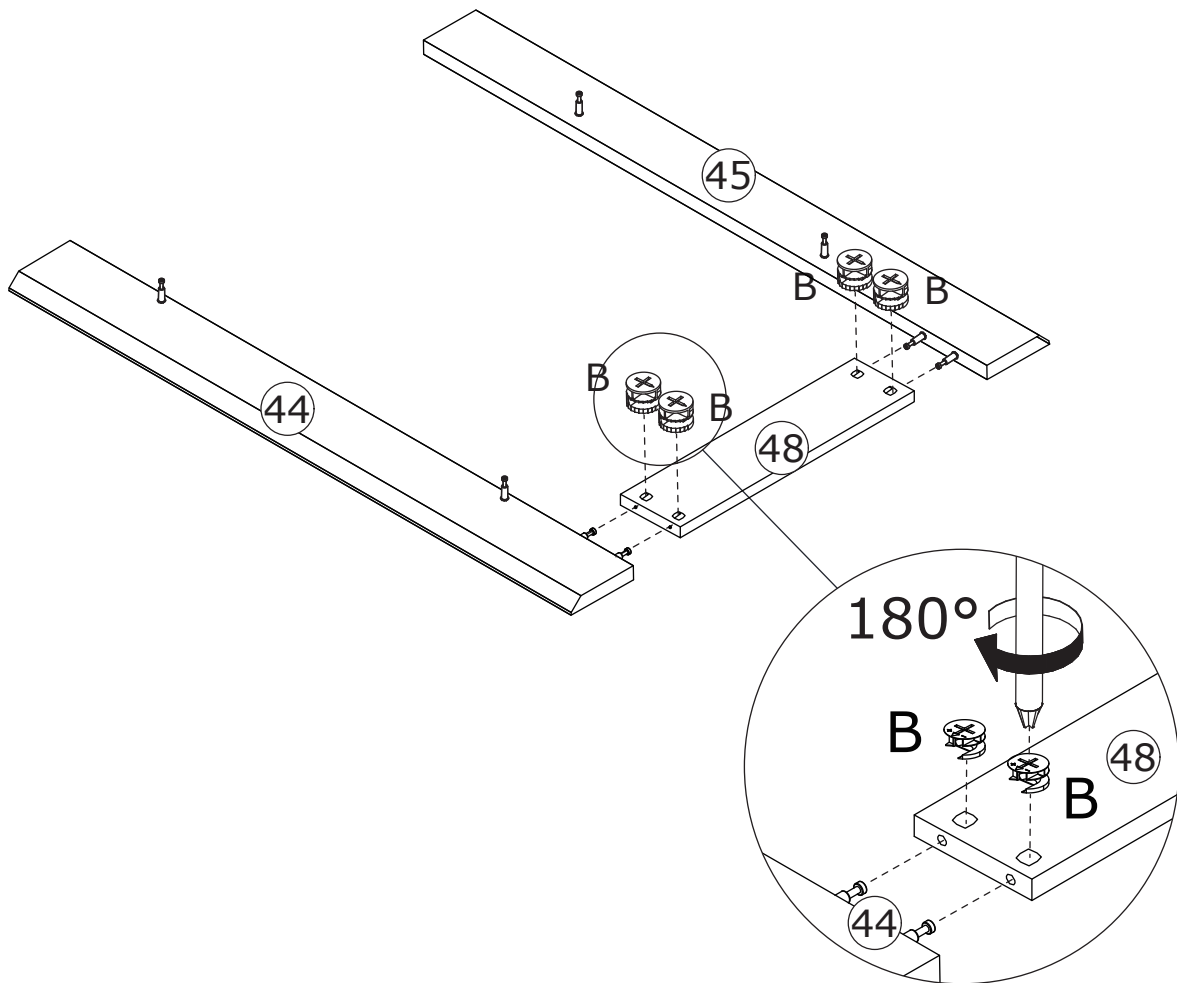

53



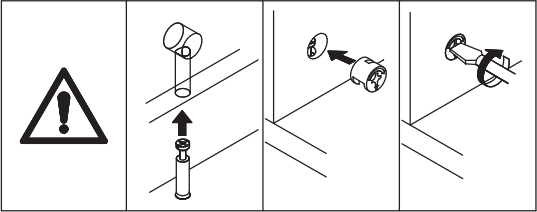
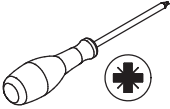

B x 4
Ø15 x 11 mm

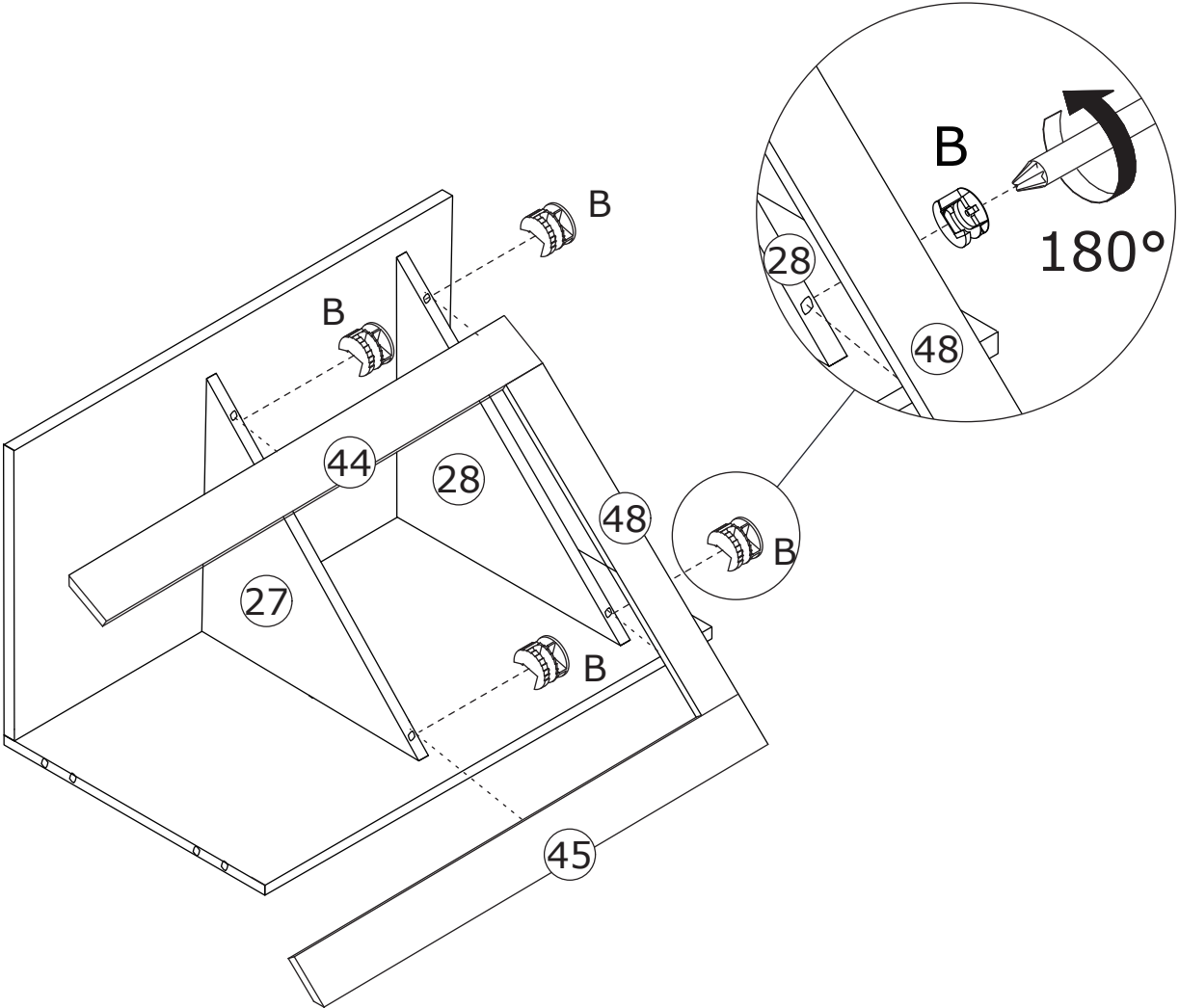

Connect plate 44, 45, and 48 to plate 27 and 28, then turn cam lock (B) clockwise to tighten as shown.

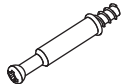

54

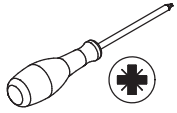
A x 4  Ø6 x 35 mm	C x 8  Ø8 x 30 mm	D x 1 	L x 2  Ø3 x 14 mm	
--	--	--	---	---

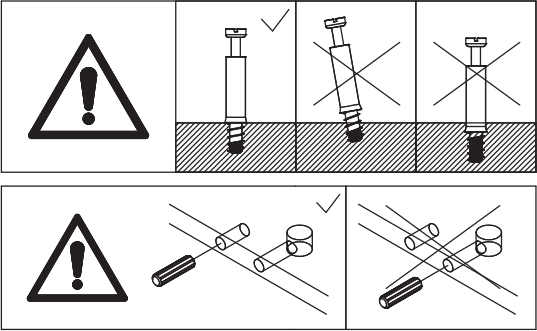

Screw eccentric rod (A) and insert wooden dowel (C) into plate 26. Next, fix magnet (D) with screw (L) as shown.

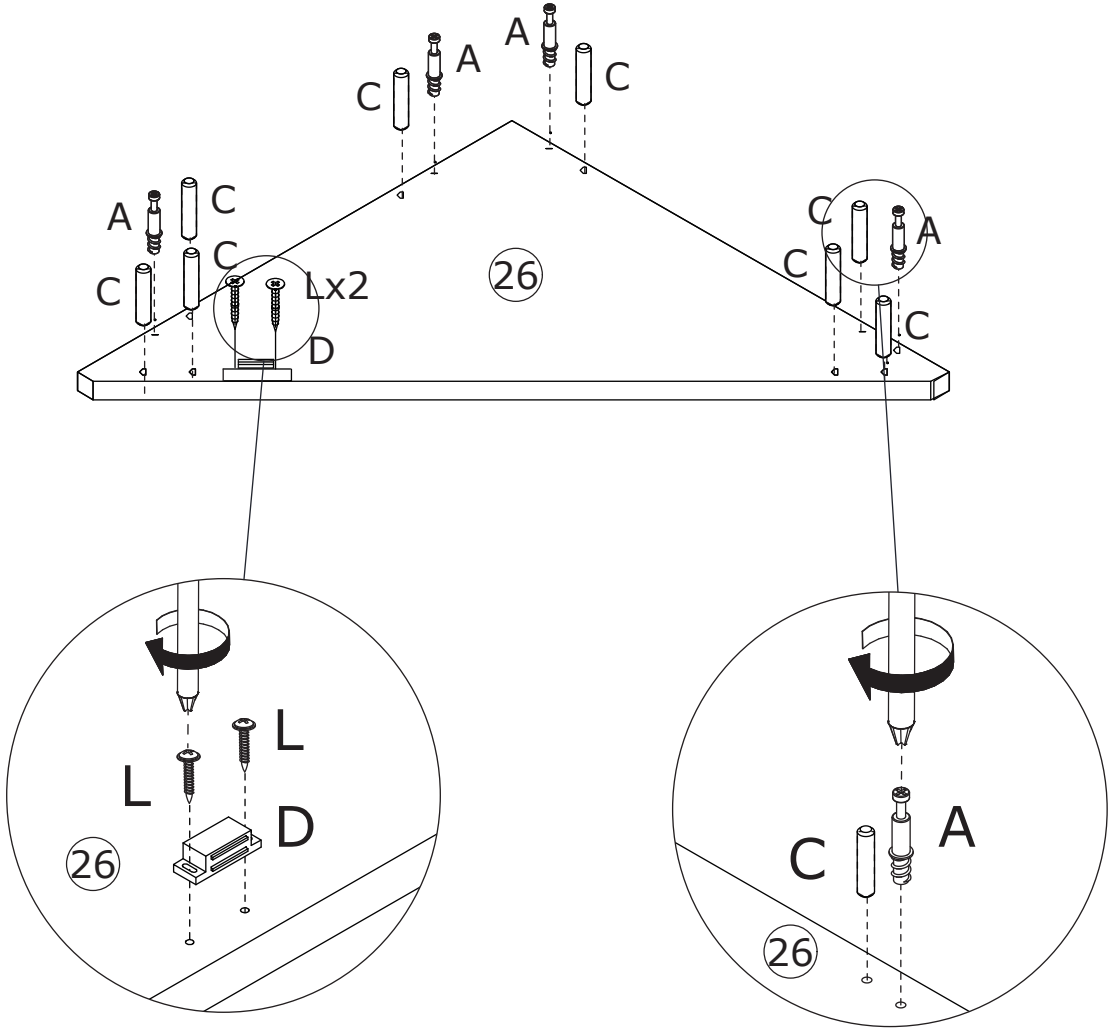

55

B x 4
Ø 15 x 11 mm

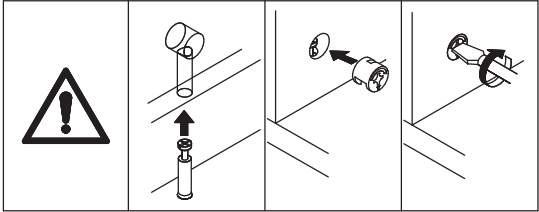
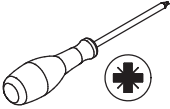

Connect plate 26 to plate 44, 45, 35 and 34, then turn cam lock (B) clockwise to tighten as shown.

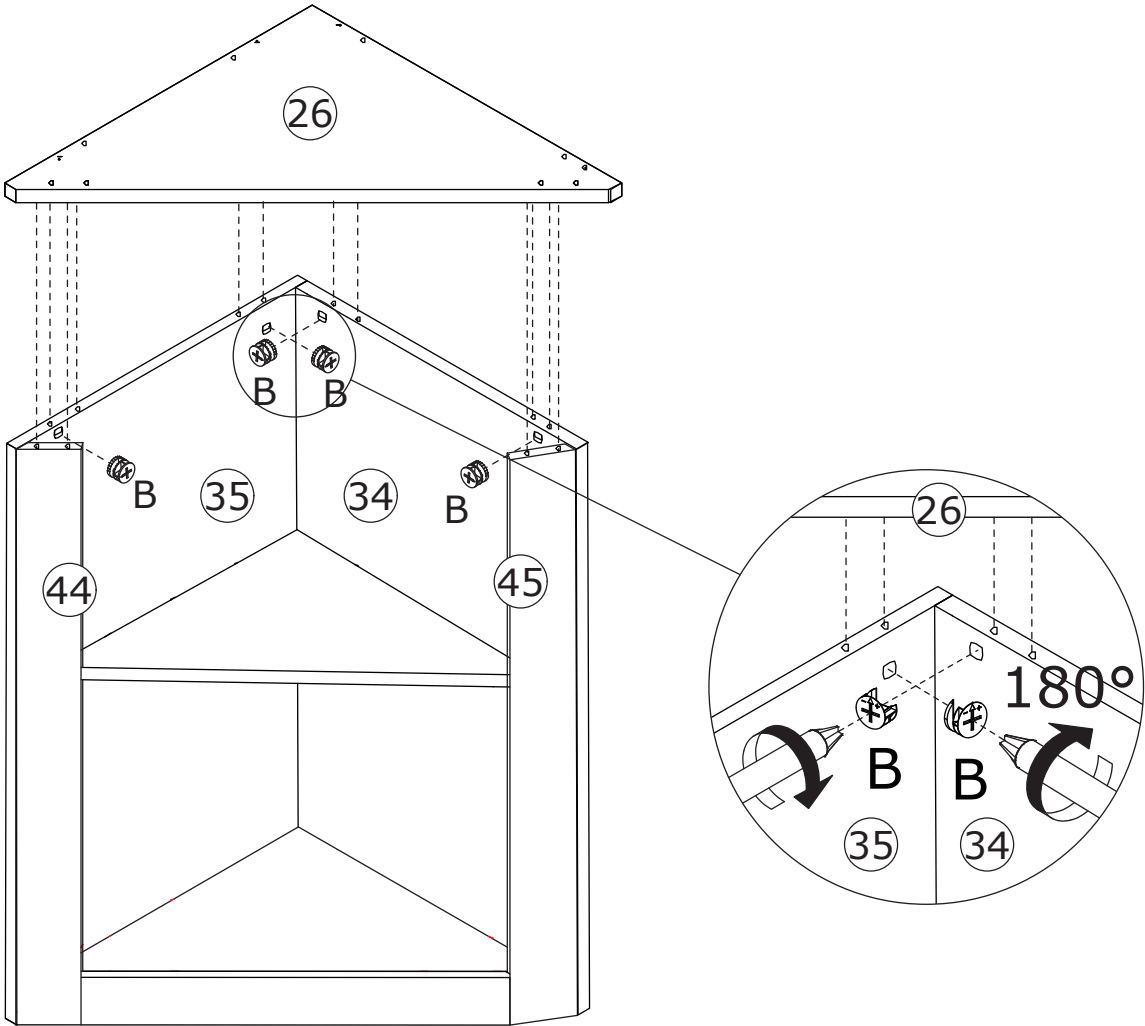

56

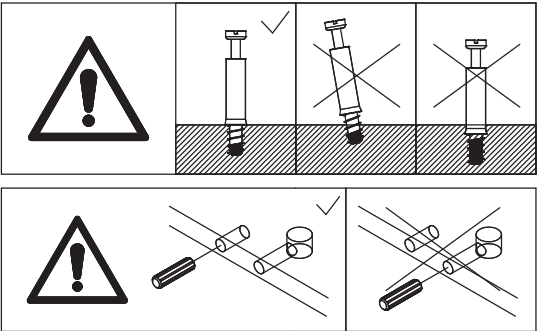
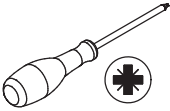
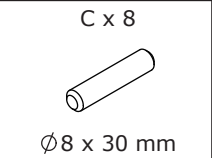
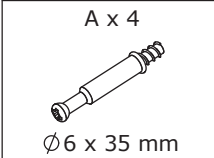

Screw eccentric rod (A) and insert wooden dowel (C) into plate 26.

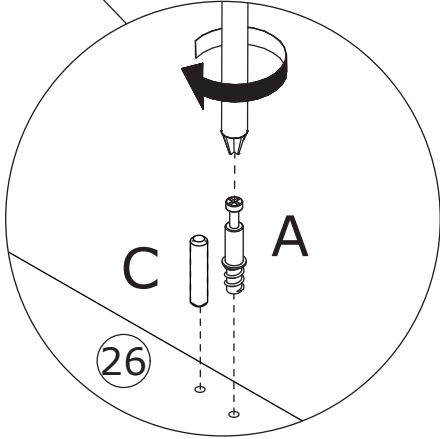
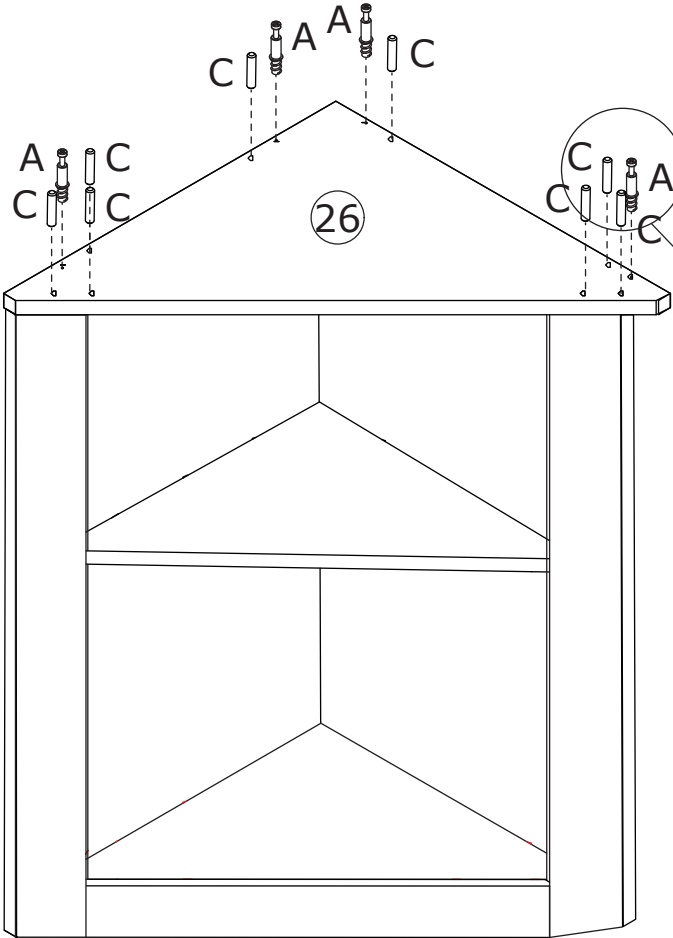

57

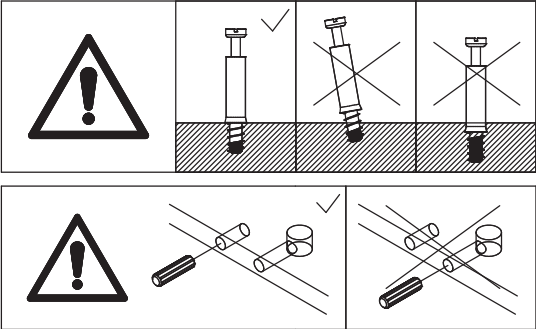
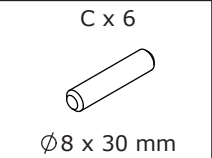
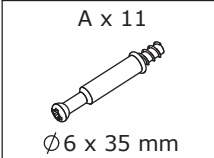

Screw eccentric rod (A) and insert wooden dowel (C) into plate 36 and 31 as shown.

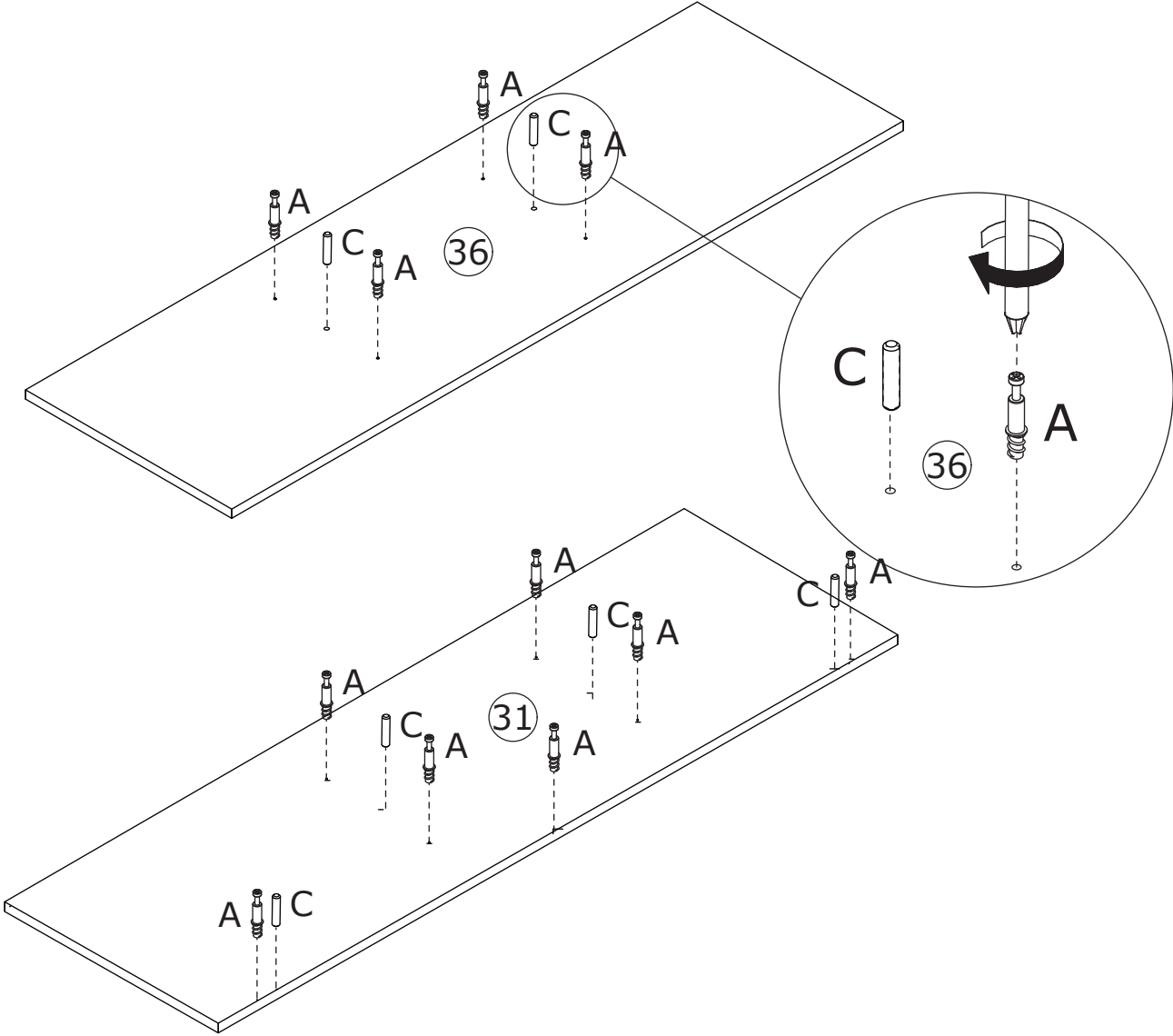

58

B x 4



Ø15 x 11 mm

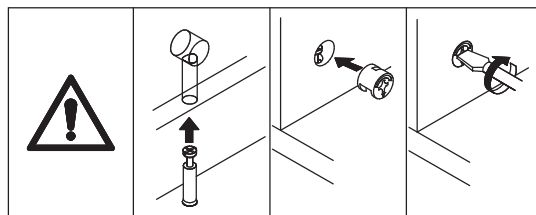
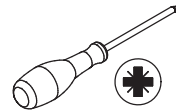

Connect plate 27 to plate 36, then turn cam lock (B) clockwise to tighten as shown.

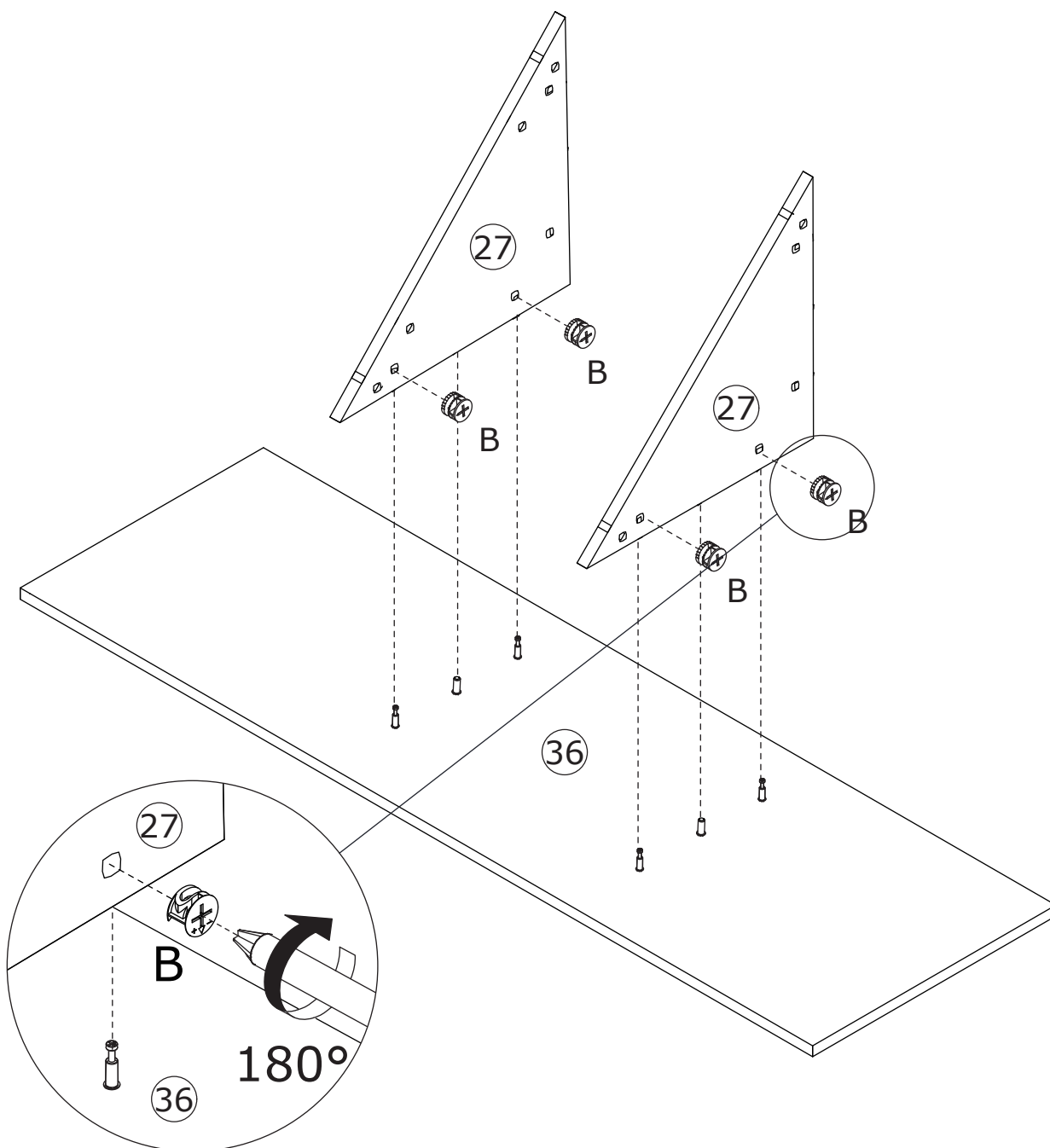

59

B x 7



Ø15 x 11 mm

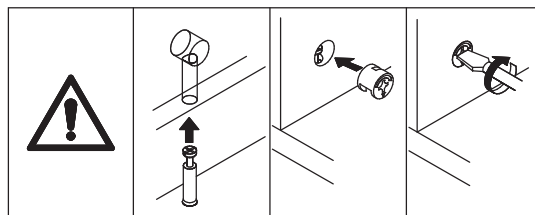
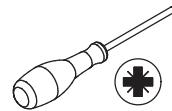

Connect plate 31 to plate 36 and 27, then turn cam lock (B) clockwise to tighten as shown.

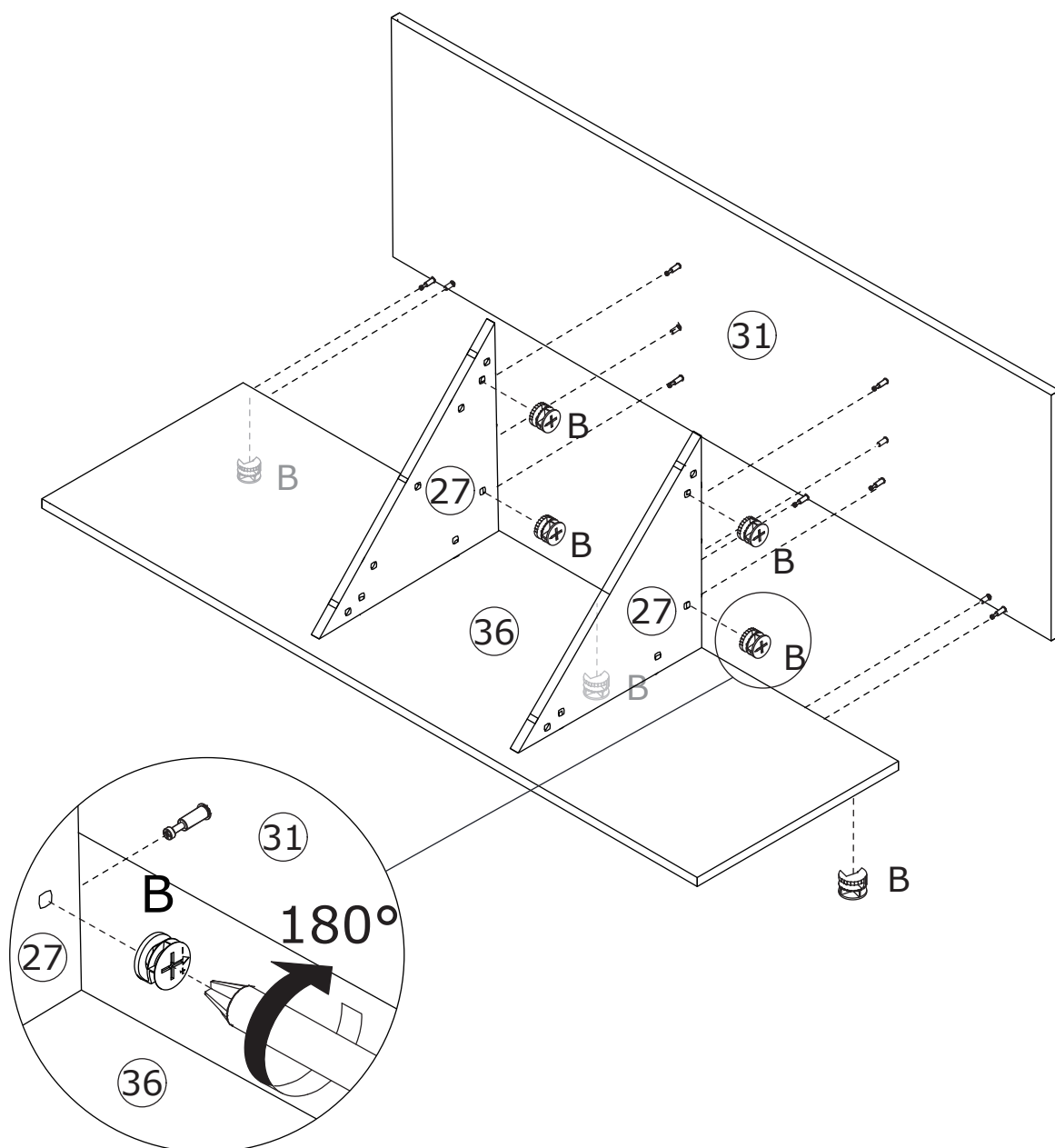

60

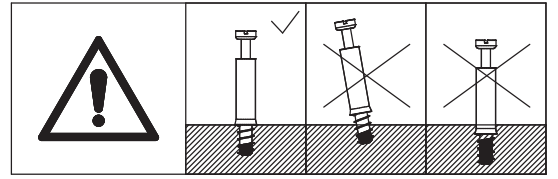
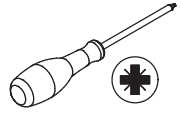
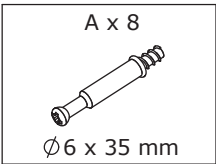

Screw eccentric rod (A) into plate 42 and 43.

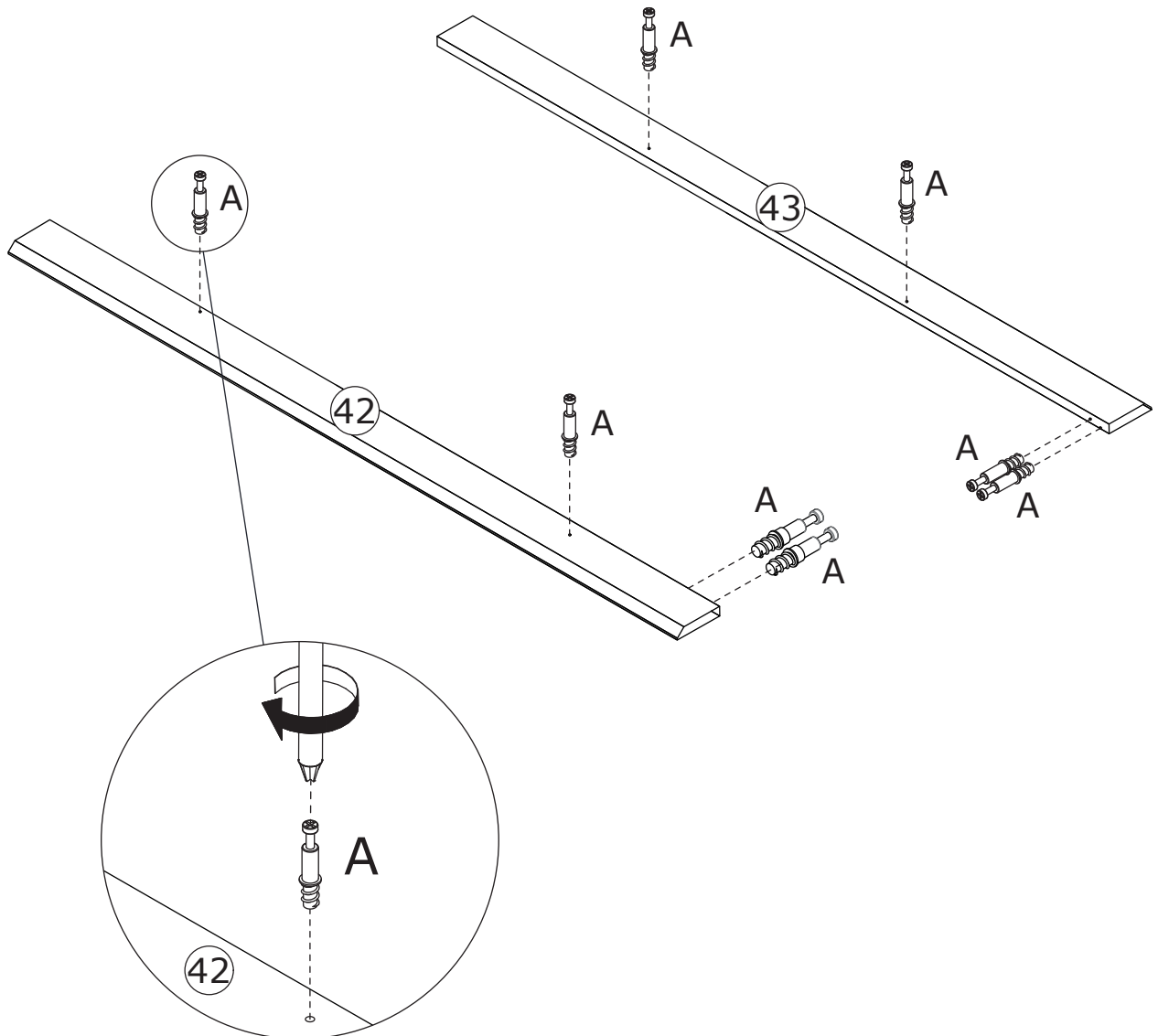

61

B x 4
Ø15 x 11 mm

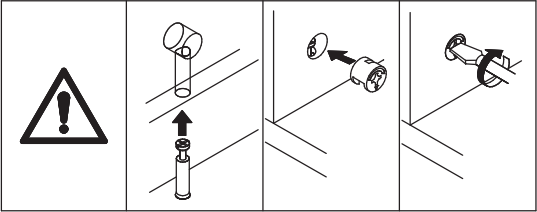
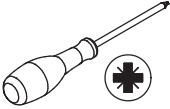

Connect plate 49 to plate 42 and 43, then turn cam lock (B) clockwise to tighten as shown.

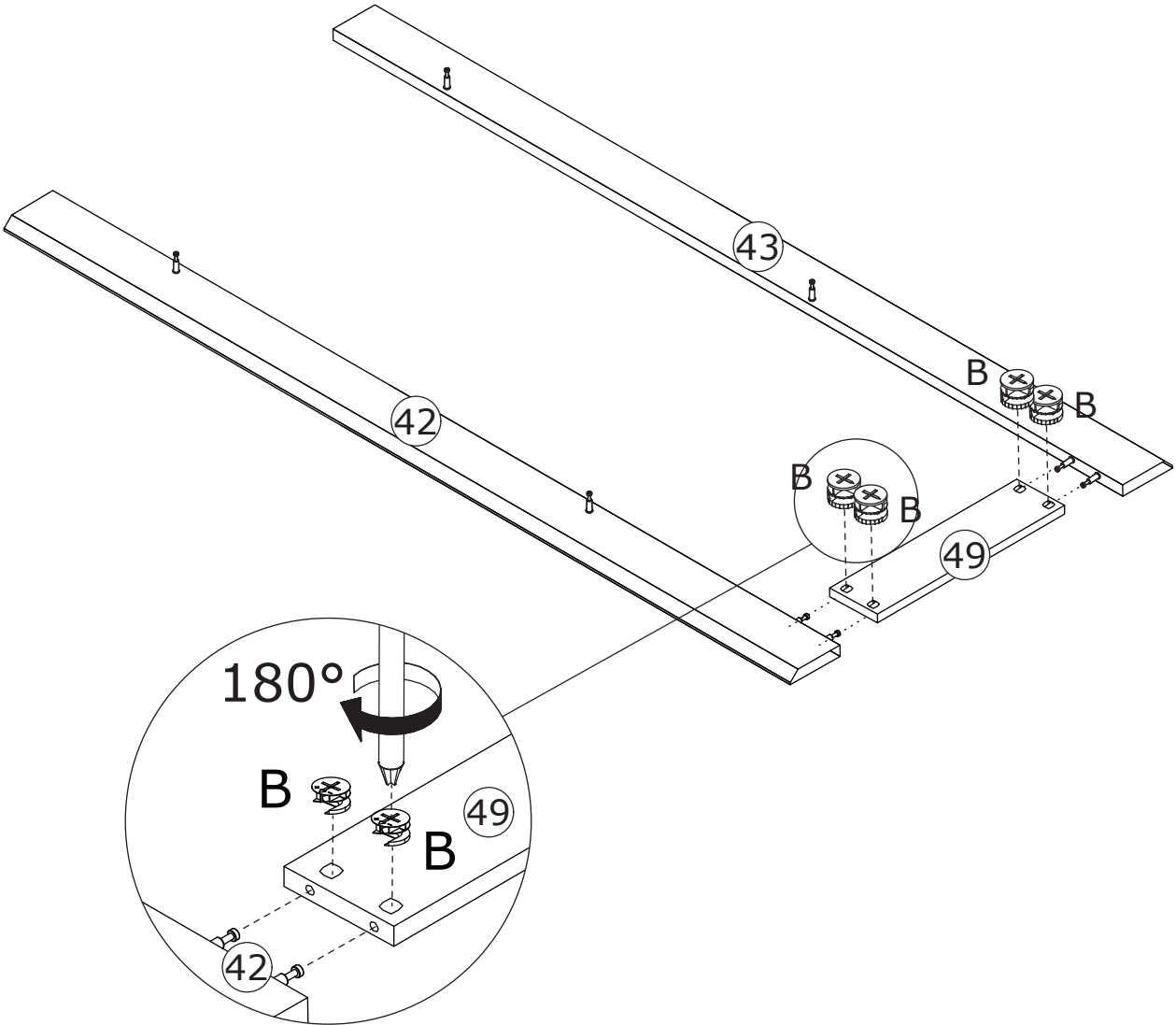

62

B x 4
Ø15 x 11 mm

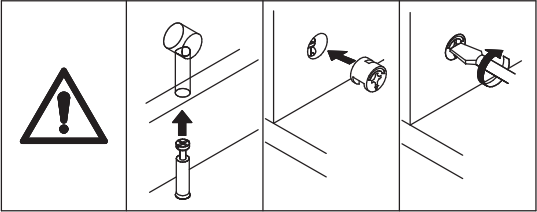
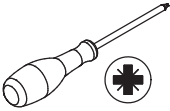

Connect plate 42 and 43 to plate 27, then turn cam lock (B) clockwise to tighten as shown.

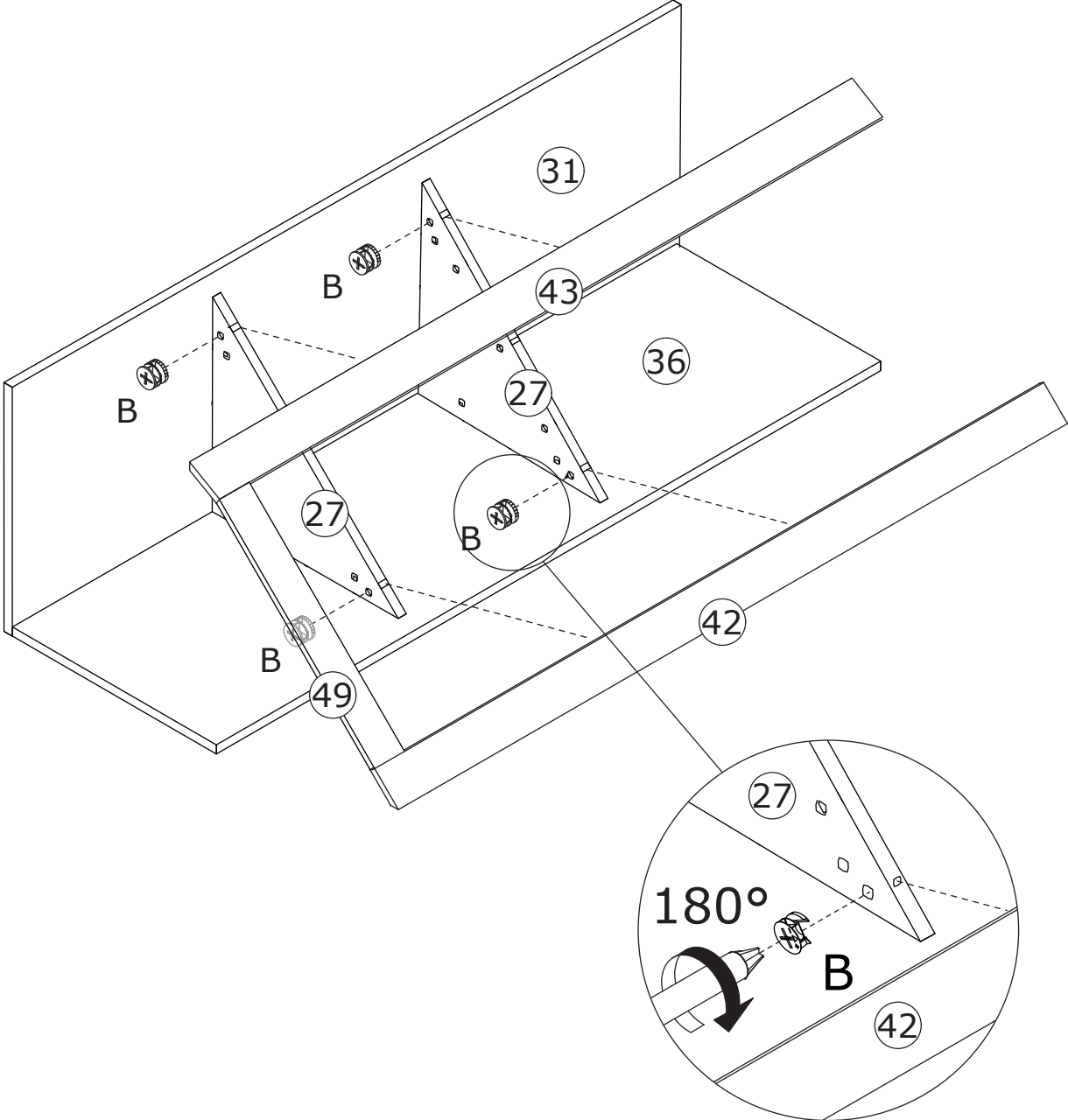

63

B x 4
Ø 15 x 11 mm

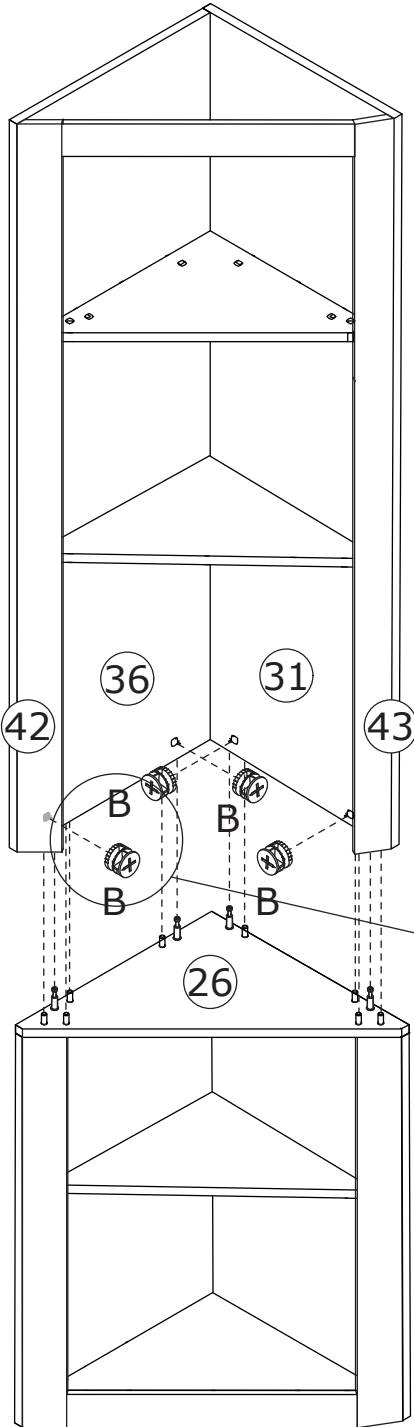
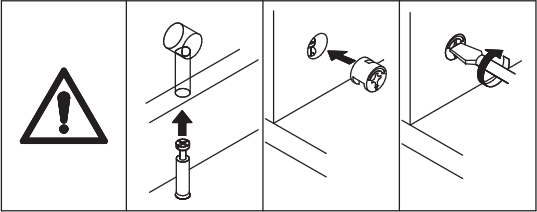
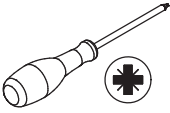

Connect the component to plate 26, then turn cam lock (B) clockwise to tighten as shown.

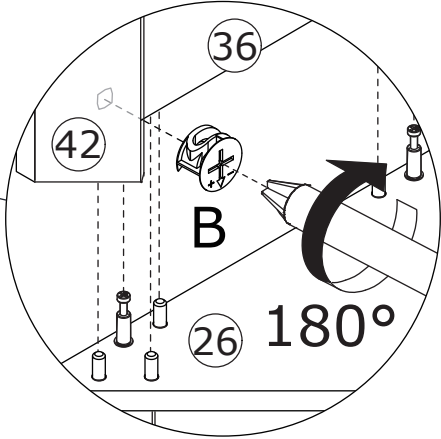

64

B x 4
Ø15 x 11 mm

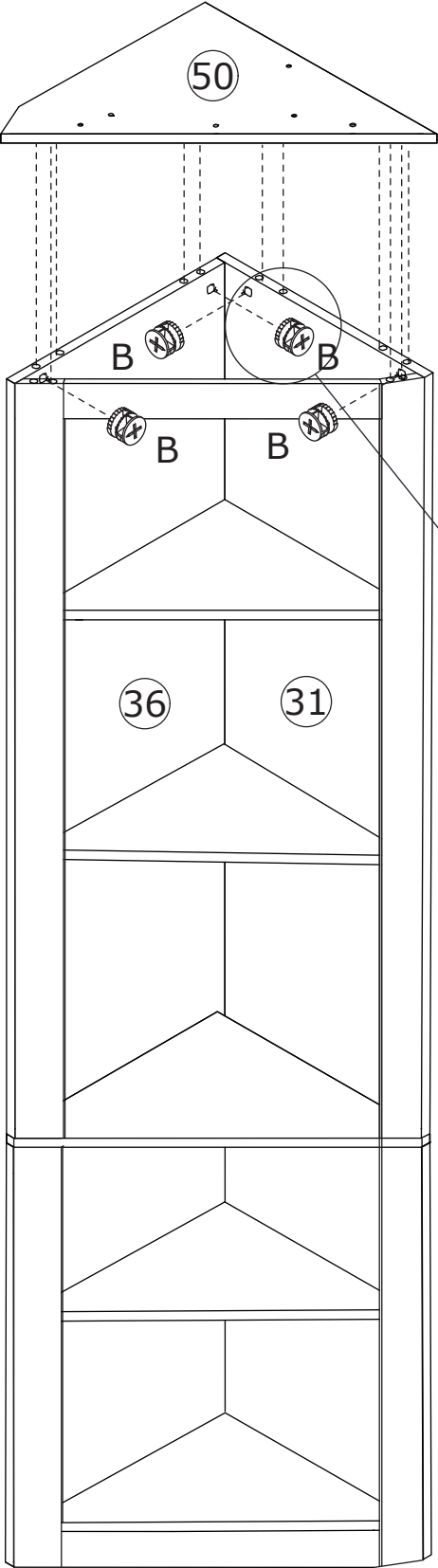
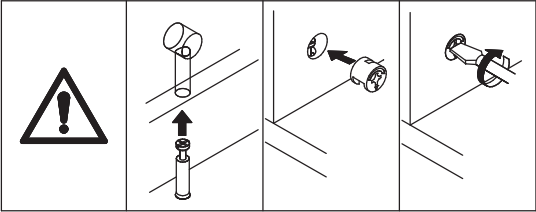
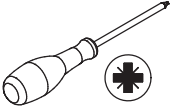

Connect late 50 to the top, then turn cam lock (B) clockwise to tighten as shown.

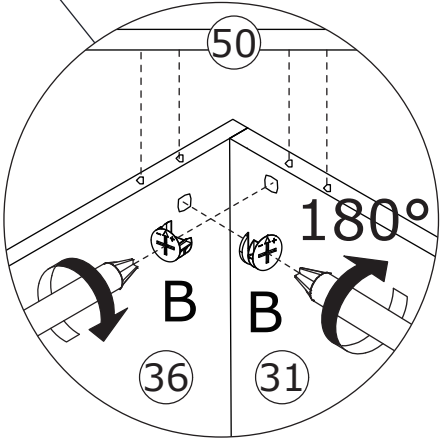

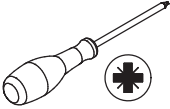
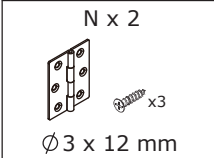

65

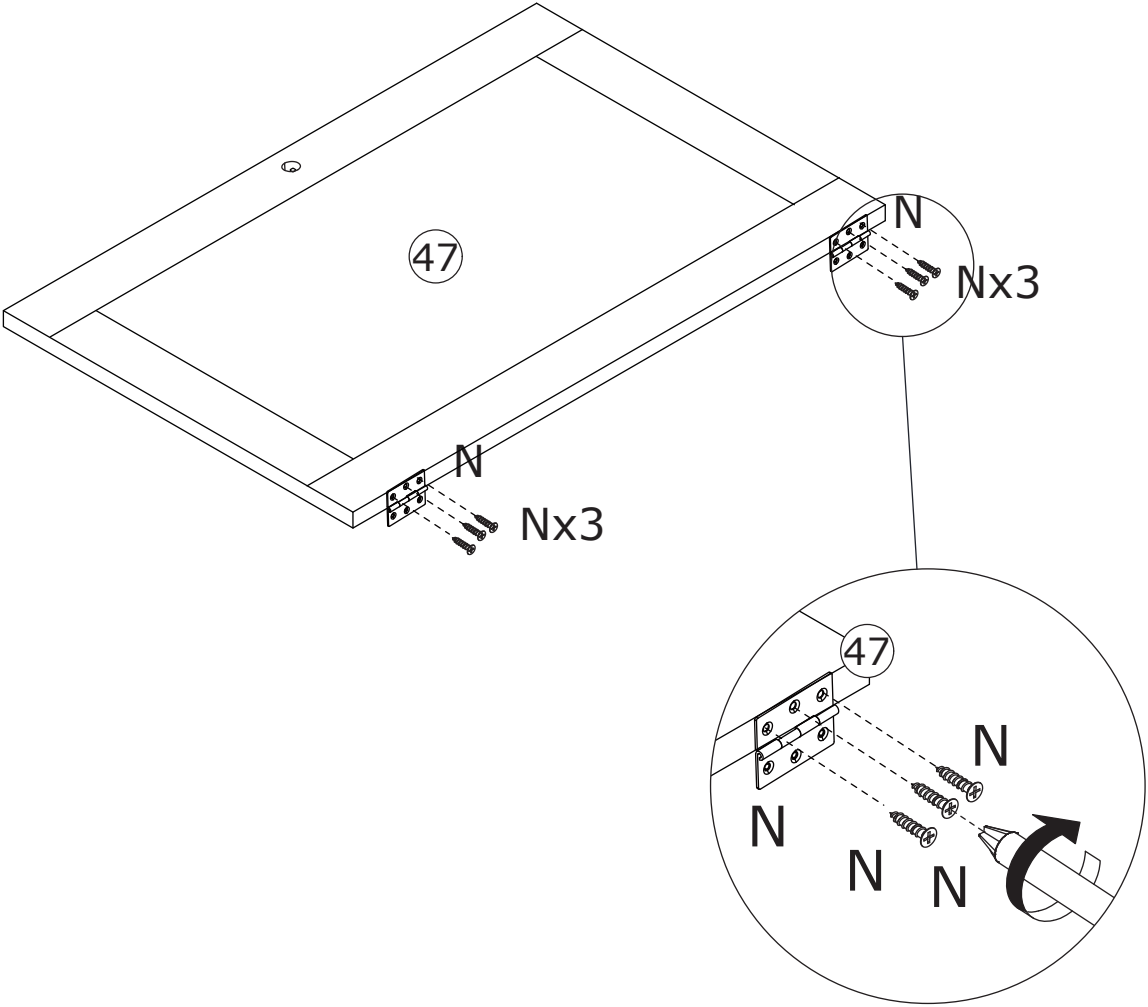

First, use screws to fix hinge (N) to plate 47 as shown.

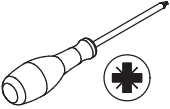

66

<p>E x 2</p>  <p>Ø3 x 12 mm</p>	<p>F x 1</p> 	<p>R x 1</p>  <p>Ø4 x 22 mm</p>	
--	--	--	---

First, fix part (F) to plate 47 using screws (E),
then fix knob (R) as shown.

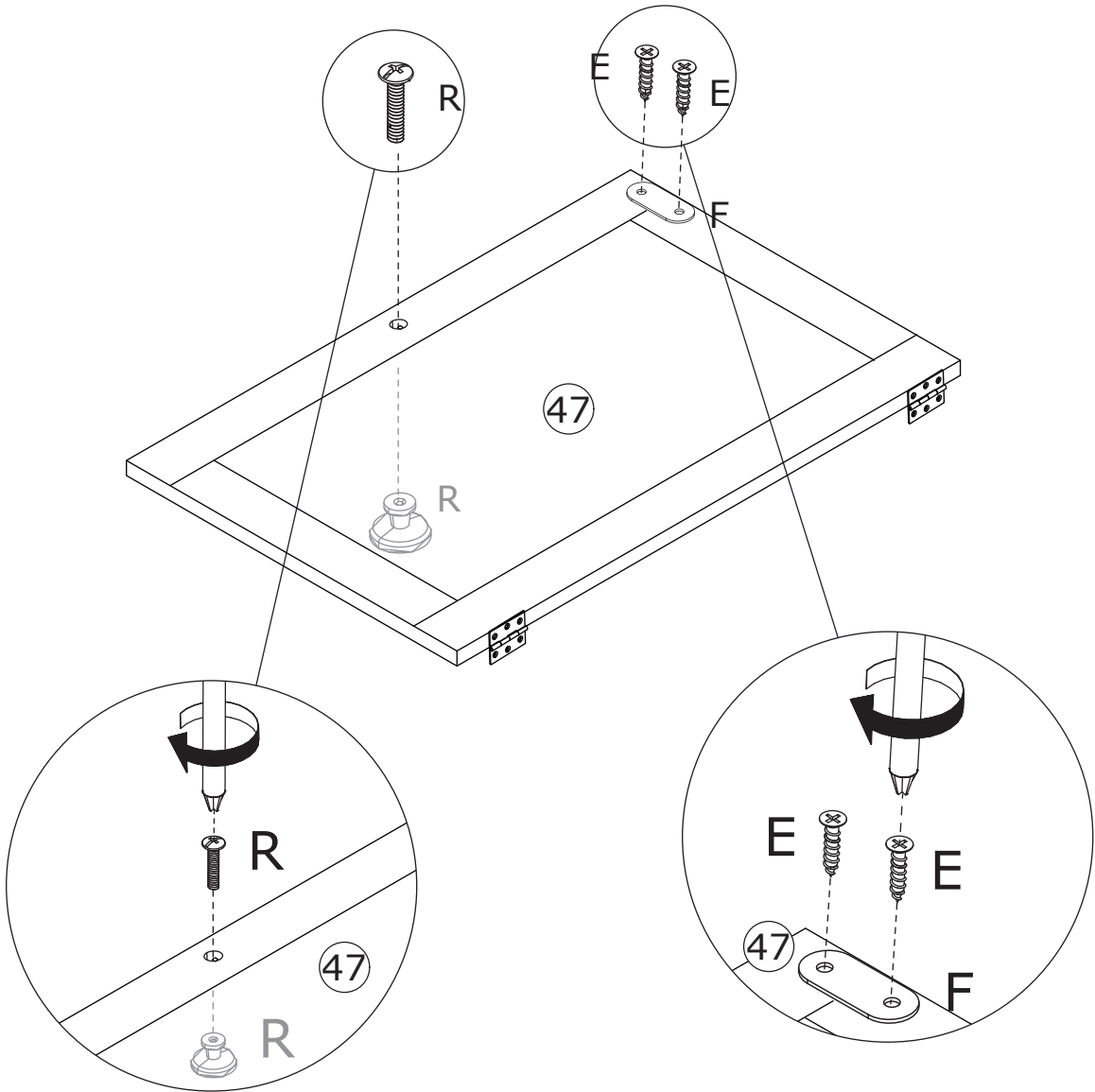

67

N x 6



Ø3 x 12 mm

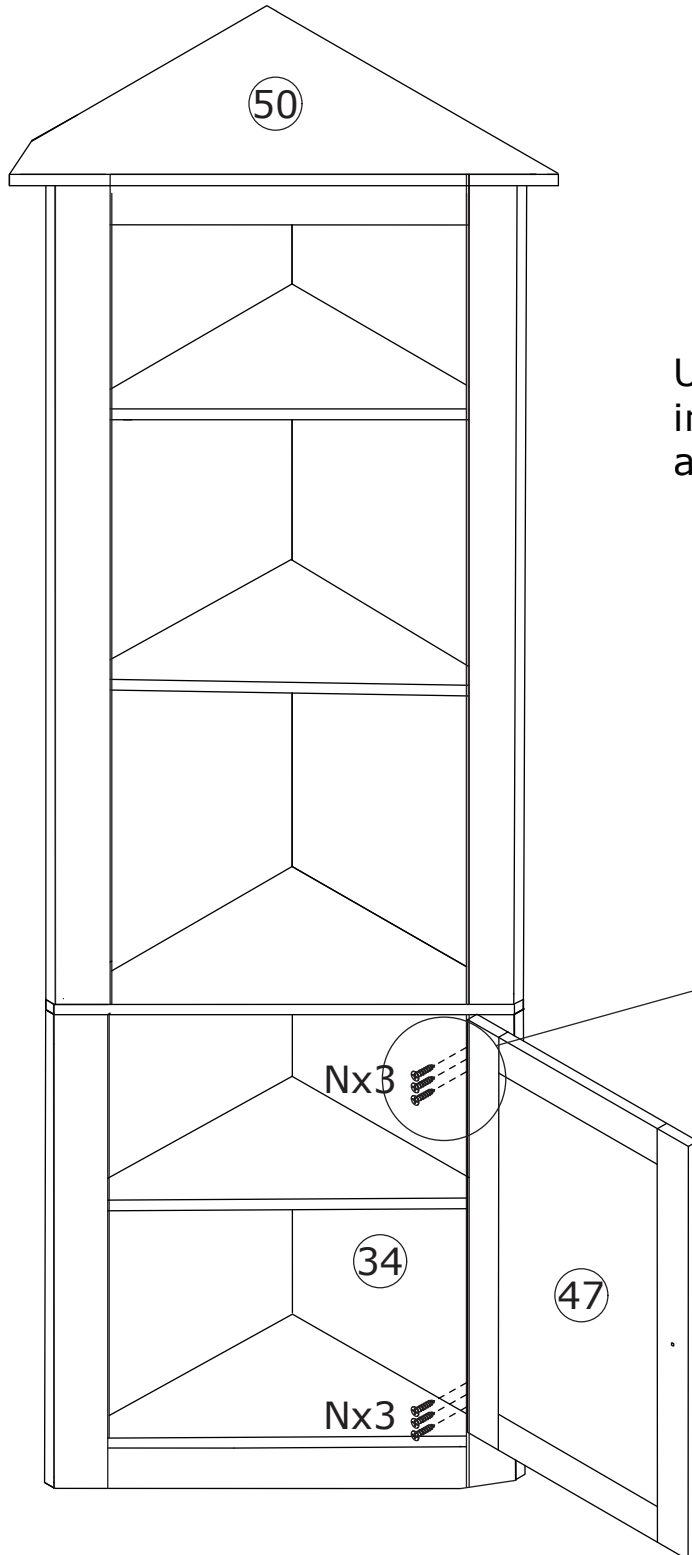
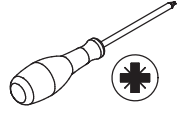

Use screw (N) to secure the installed hinges to plate 34 as shown.

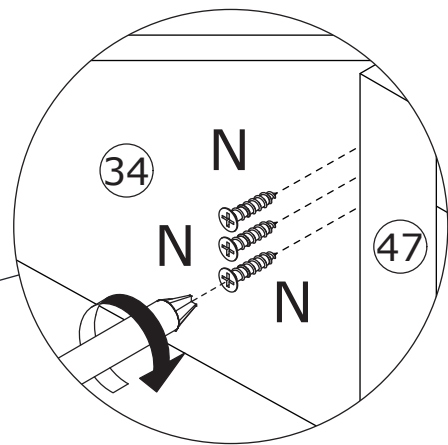

68

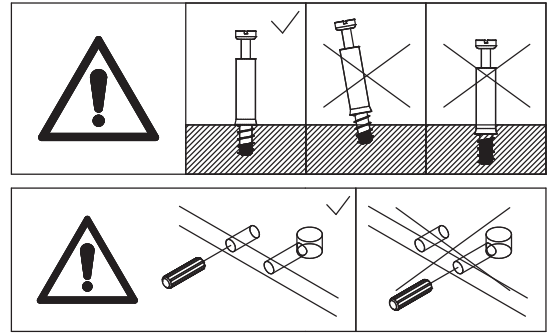
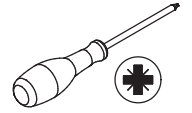
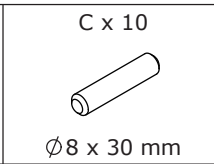
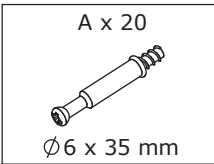

Screw eccentric rod (A) and insert wooden dowel (C) into plate 55, 56, and 59 as shown.

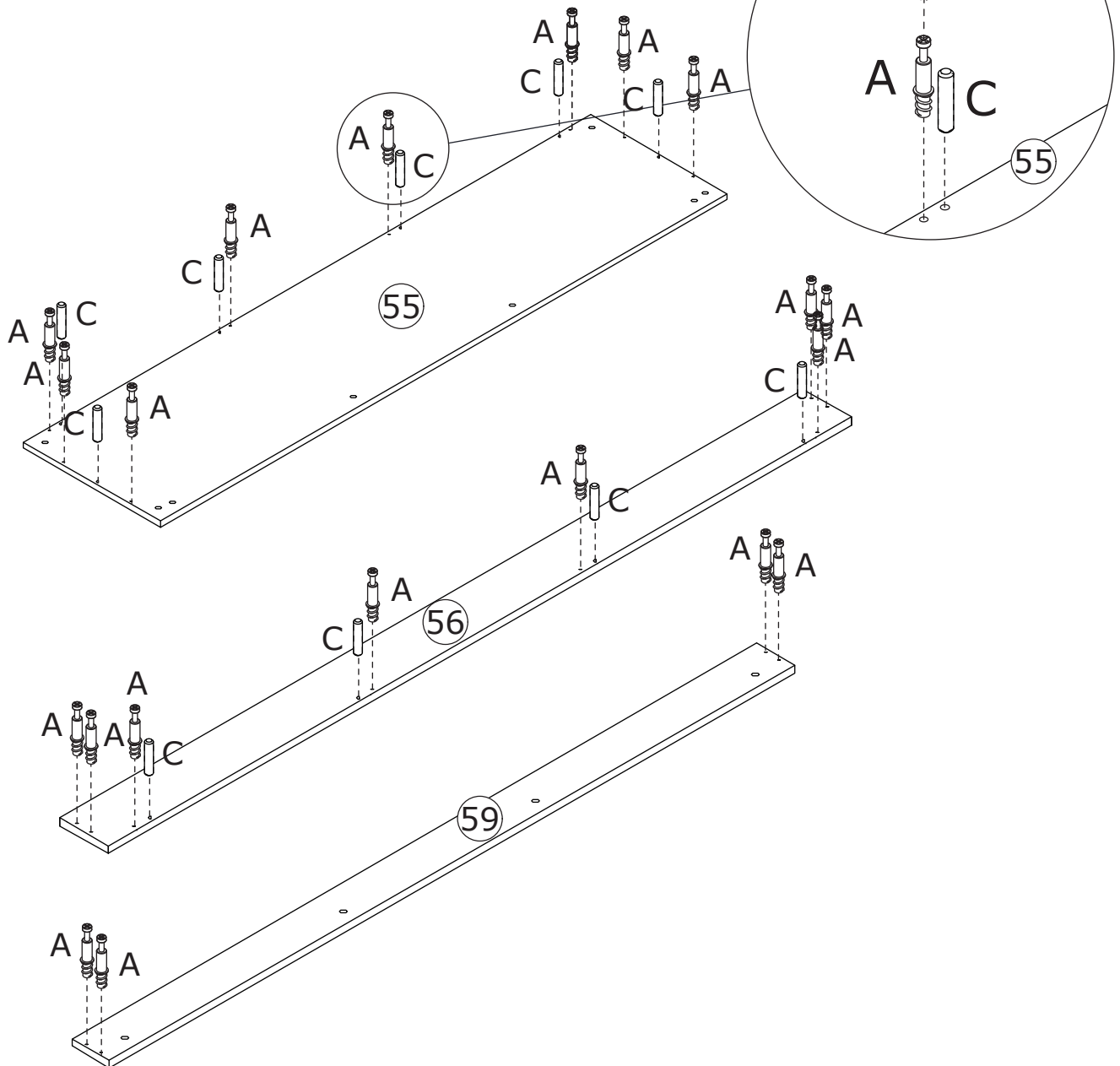

69

B x 4



Ø15 x 11 mm

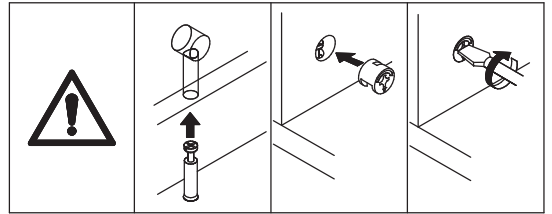
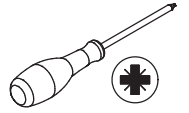

Connect plate 57 and 58 to plate 59, then turn cam lock (B) clockwise to tighten as shown.

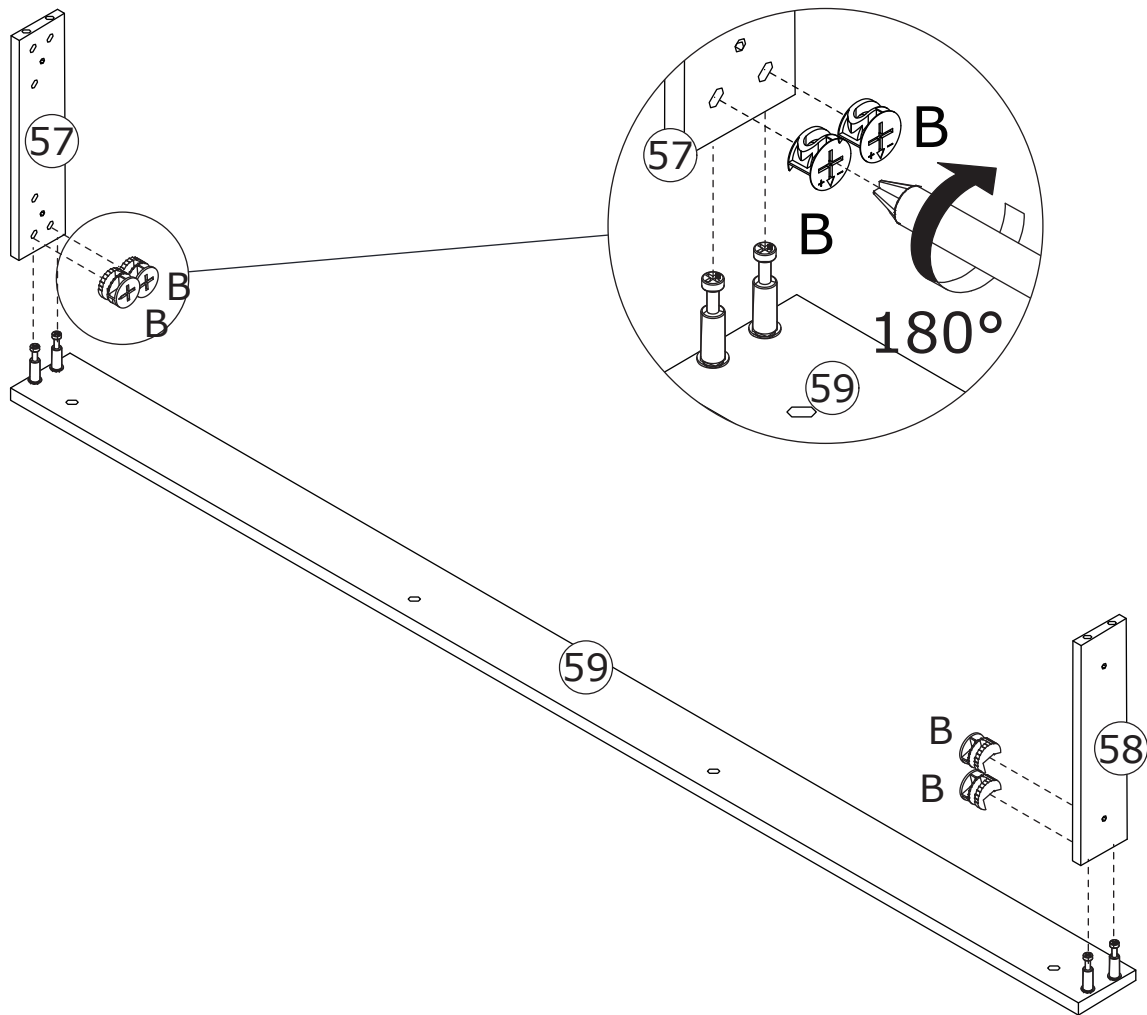

70

B x 8
Ø15 x 11 mm

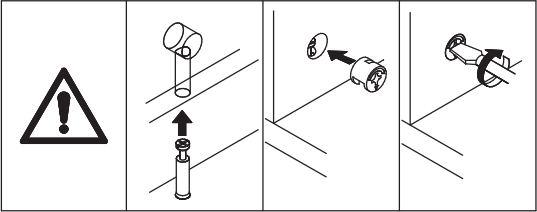
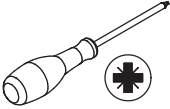

Connect plate 57, 58 and 59 to plate 55, then turn cam lock (B) clockwise to tighten as shown.

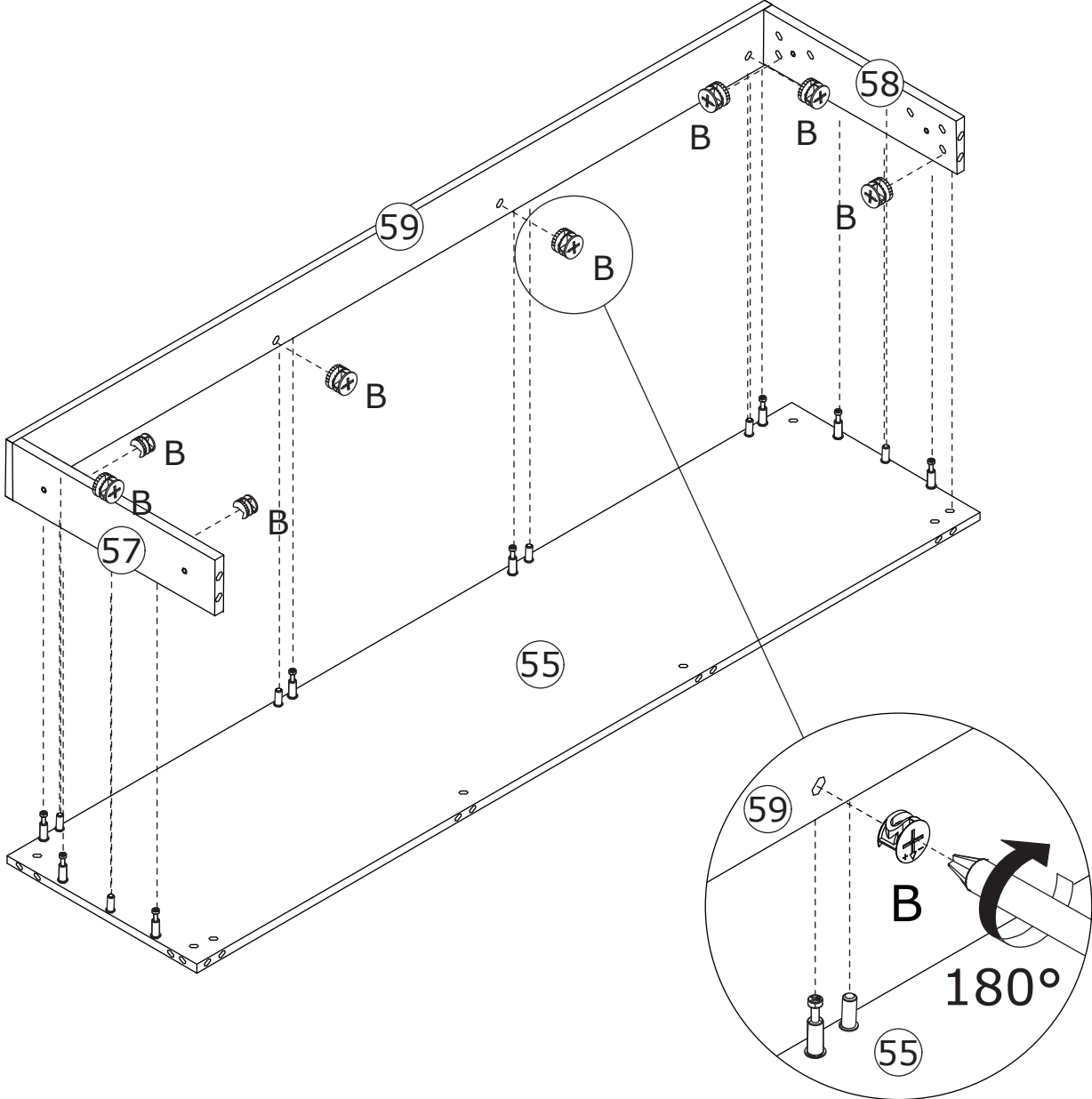

71

B x 8
Ø15 x 11 mm

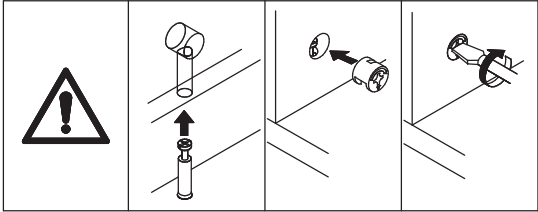
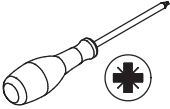

Connect plate 56 to plate 57, 58 and 55, then turn cam lock (B) clockwise to tighten as shown.

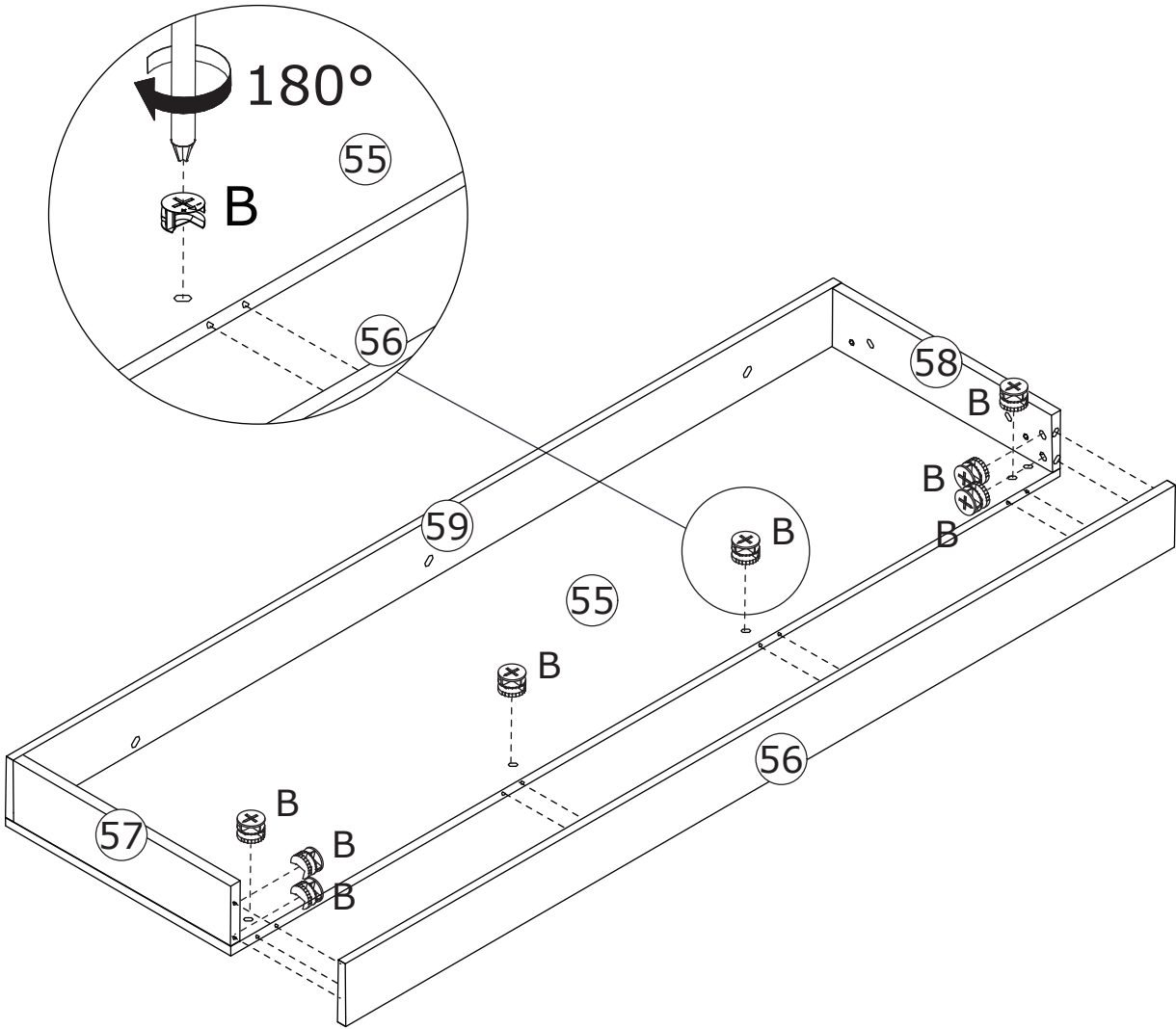

72

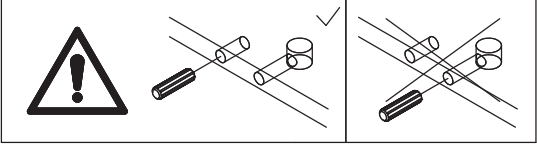
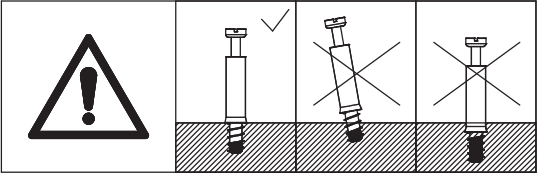
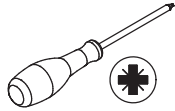
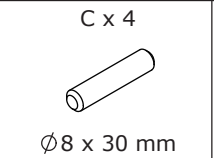
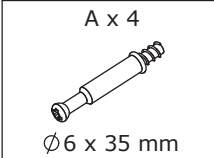

Screw eccentric rod (A) and insert wooden dowel (C) into plate 30 and 36 as shown.

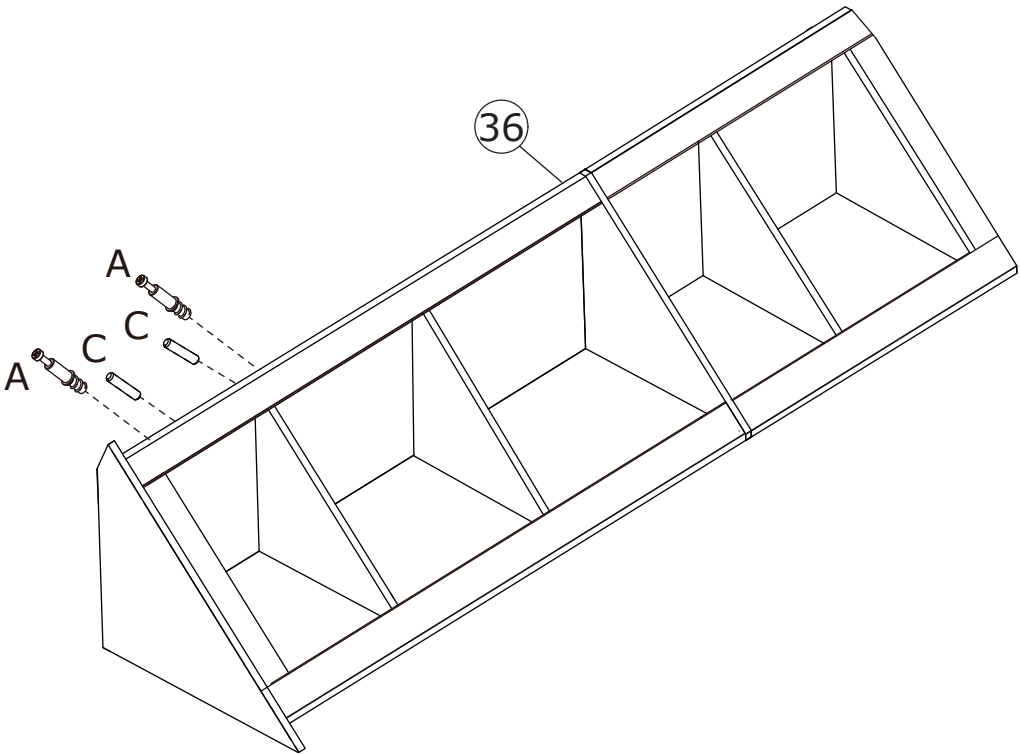
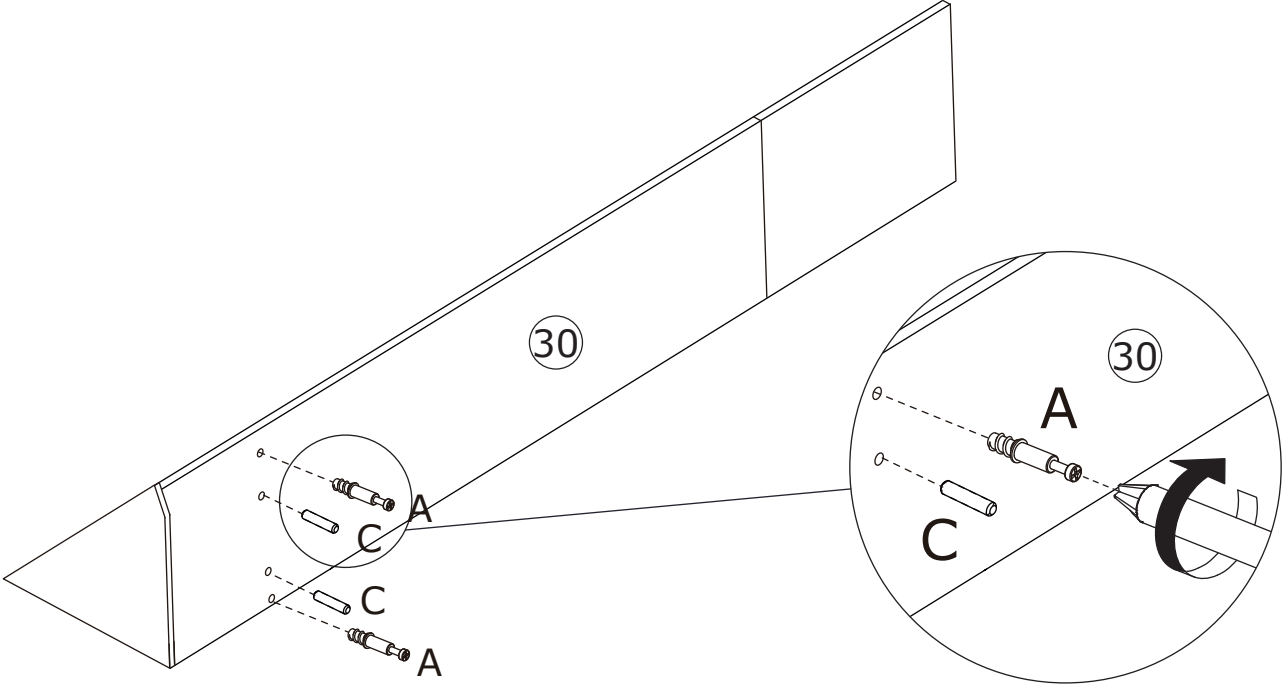

73

B x 4
Ø15 x 11 mm

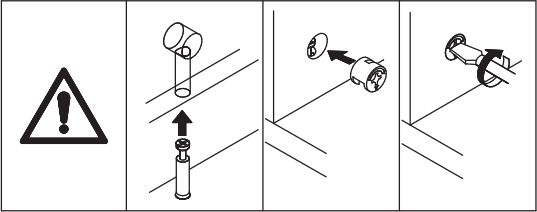
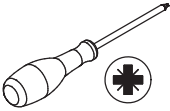

Connect plate 30 and 36 to plate 55, then turn cam lock (B) clockwise to tighten as shown.

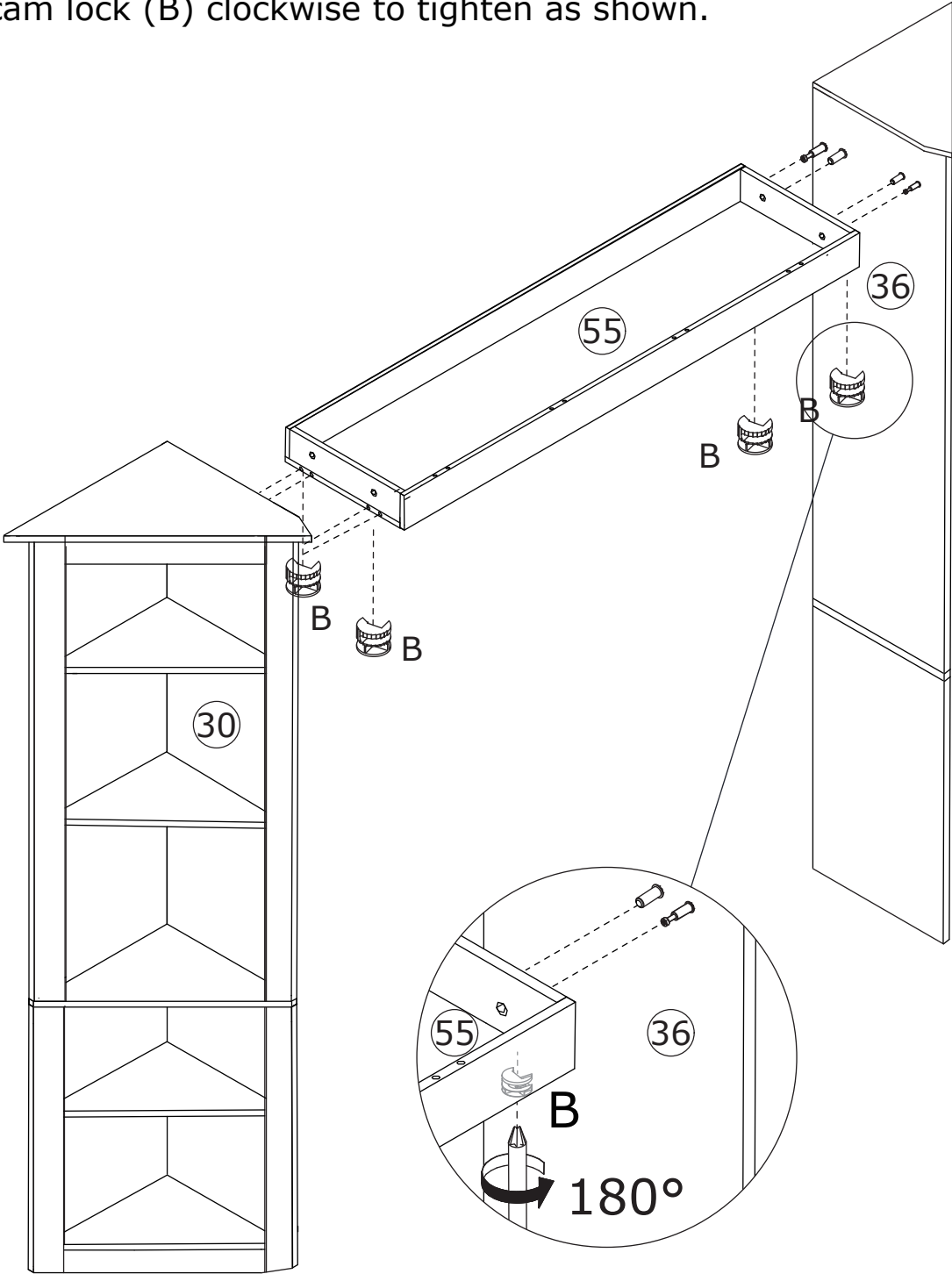

74

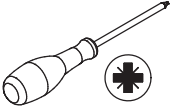
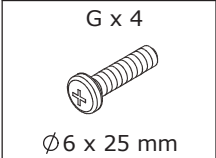

Use screw (G) to secure plate 58 and 57 to plate 30 and 36 as shown.

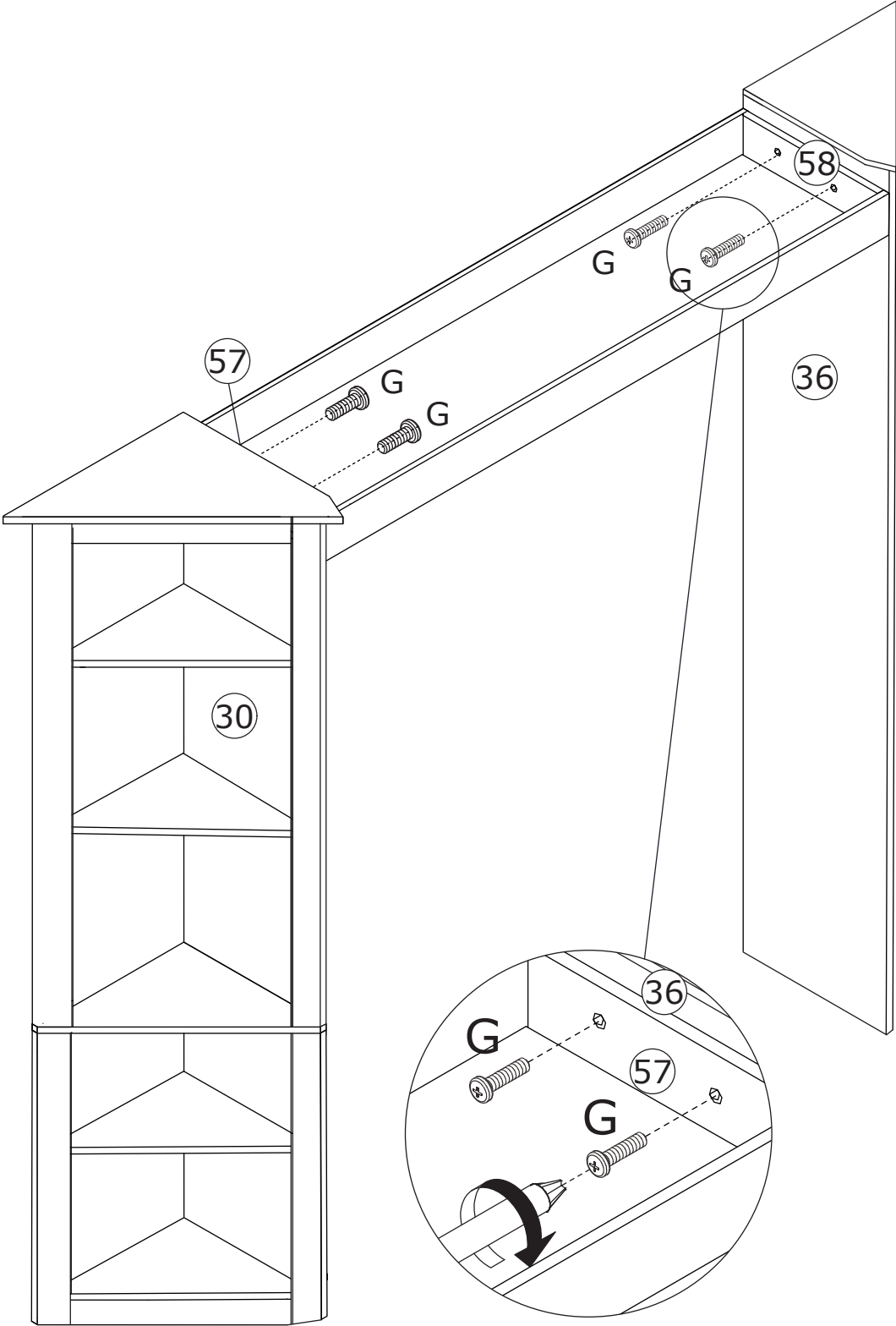

75

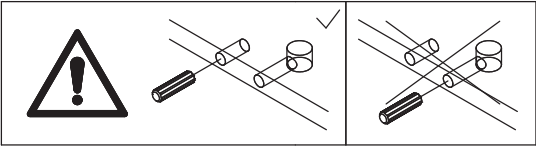
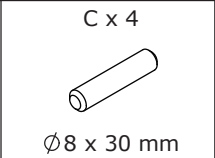
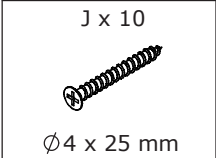

First, insert dowel (C) into plate 56, then secure plate 52 to plate 56 using self-tapping screw (J) as shown.

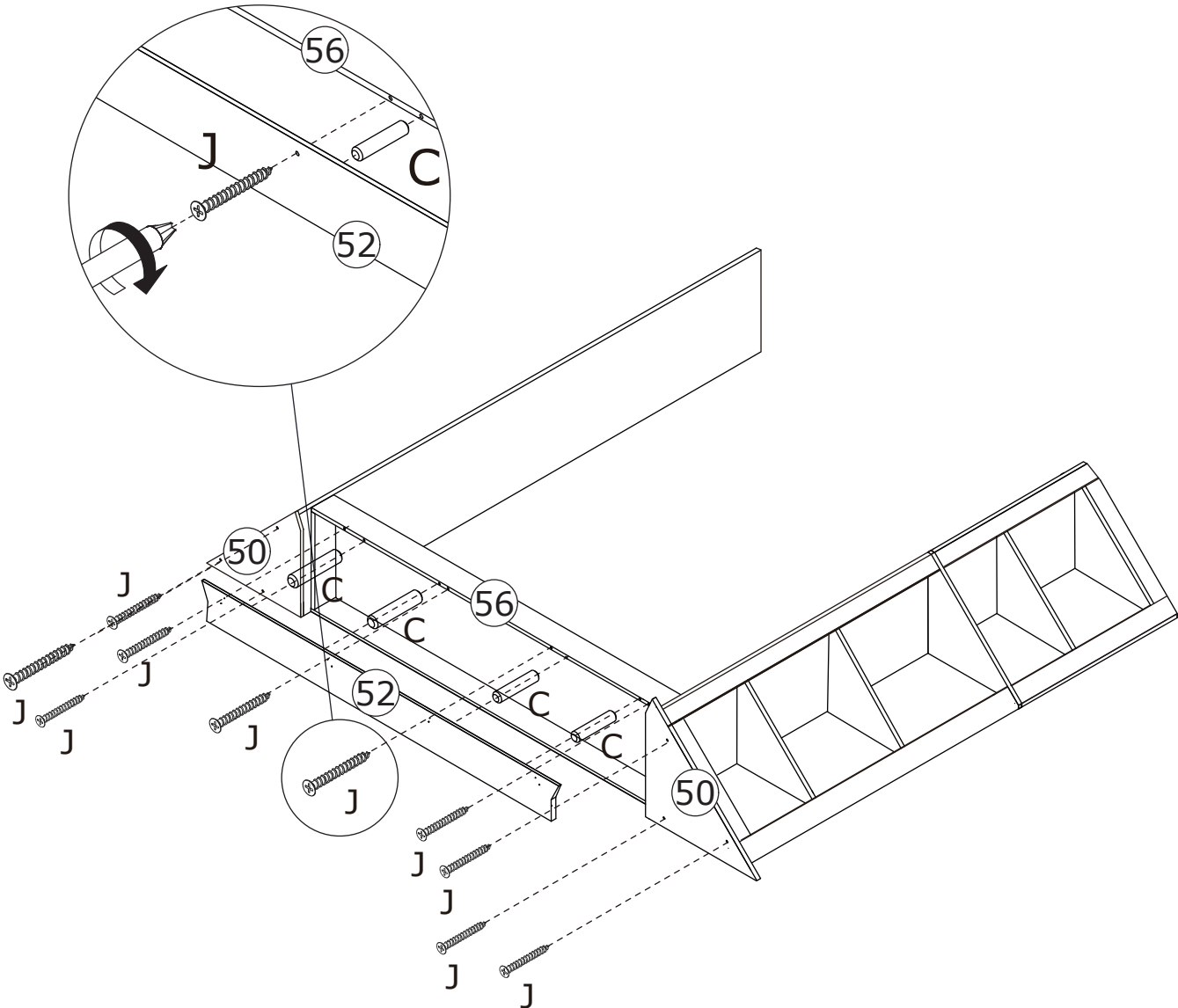

76

J x 10

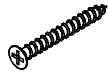

Ø4 x 25 mm

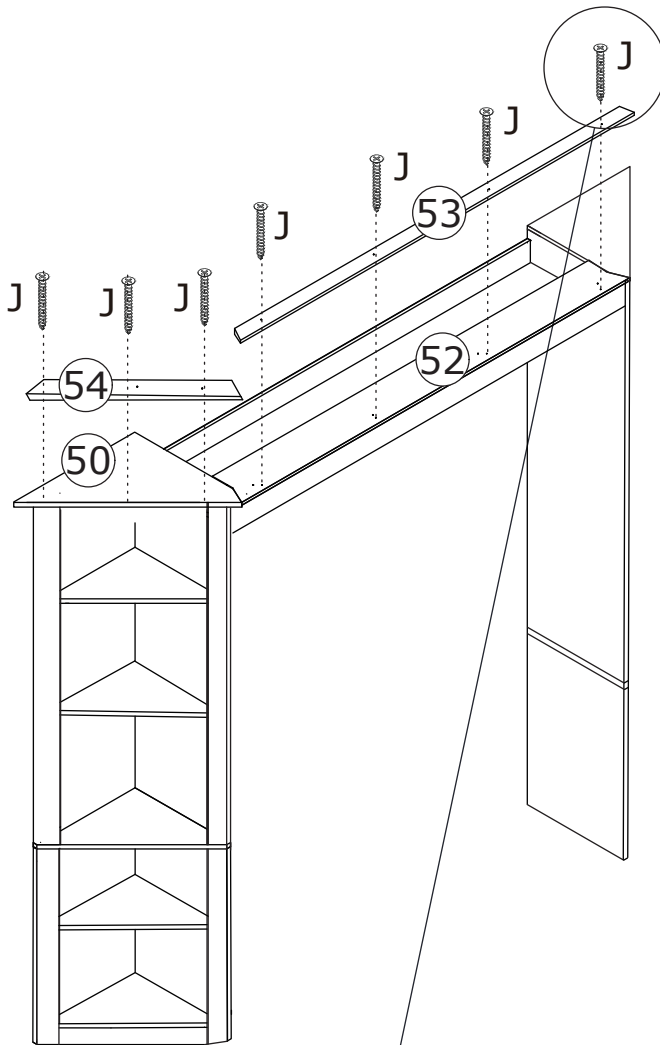
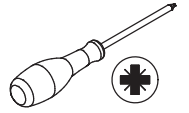

Secure plate 53, 61 and 54 to plate 52 and 50 using self-tapping screw (J).

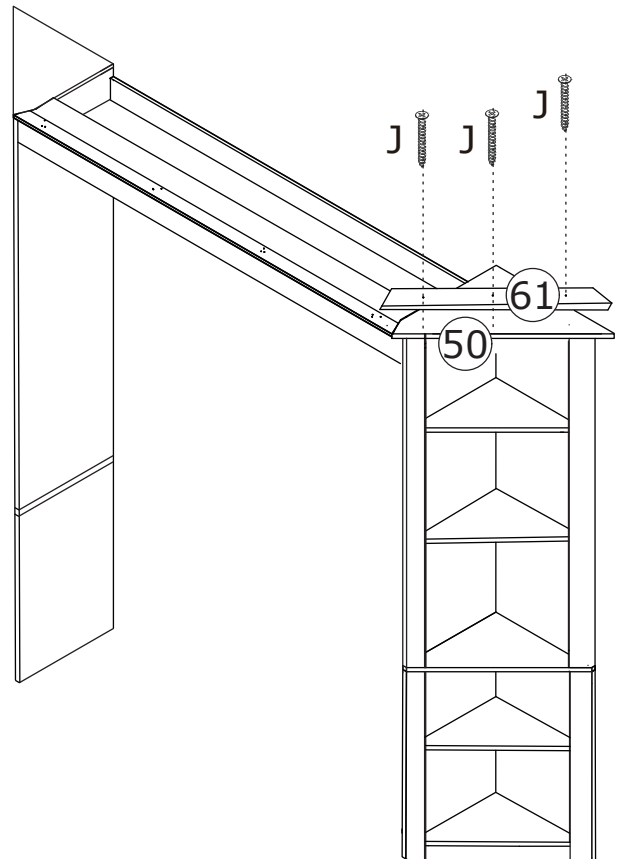
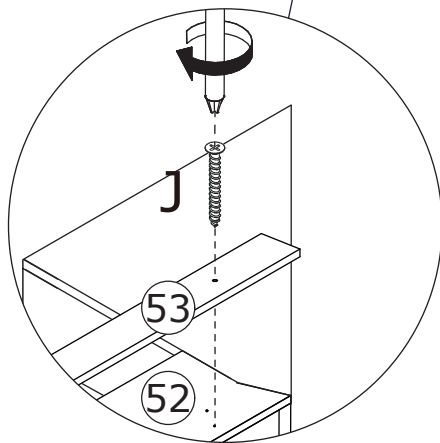

77

Push the middle cabinet between the two cabinets, as shown.

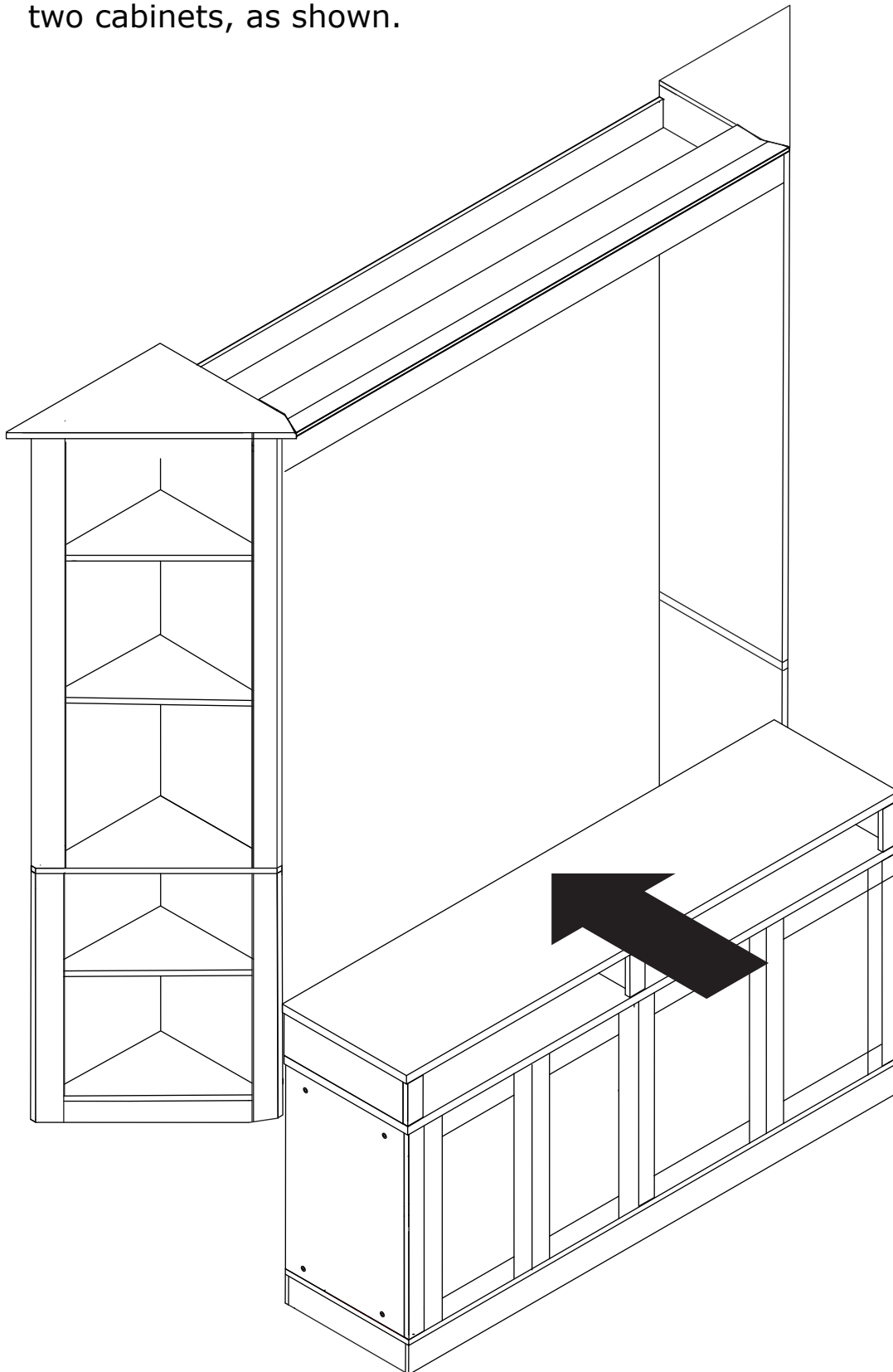

78

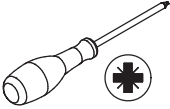
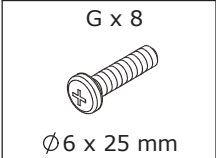

Open the door, then secure plate 11 and 12 to plate 32 and 34 using screw (G) as shown.

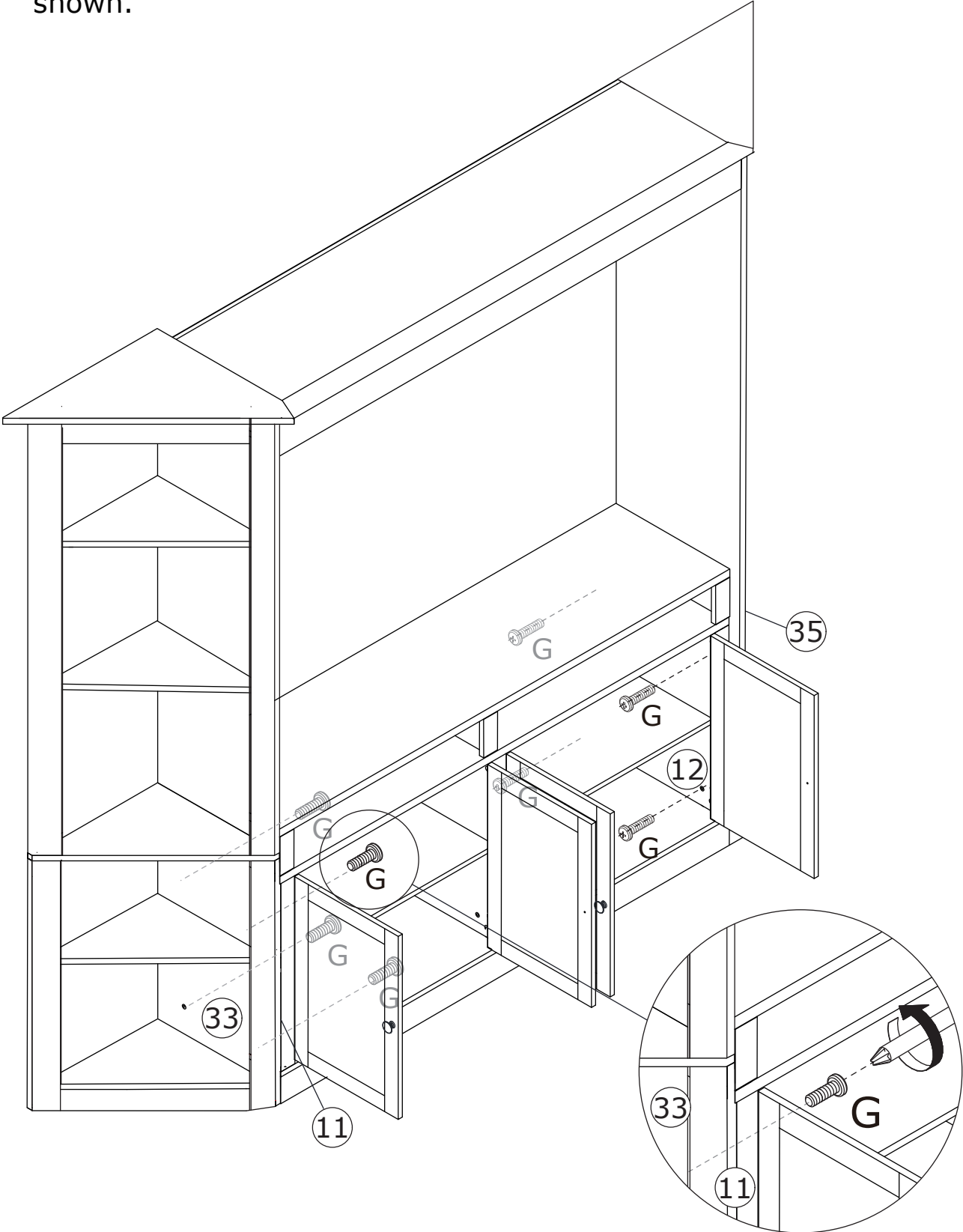

79

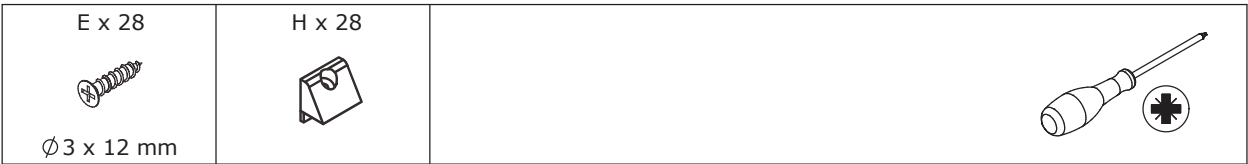

Insert the buckle (H) into the rear slots and fix with screw (E) as shown.

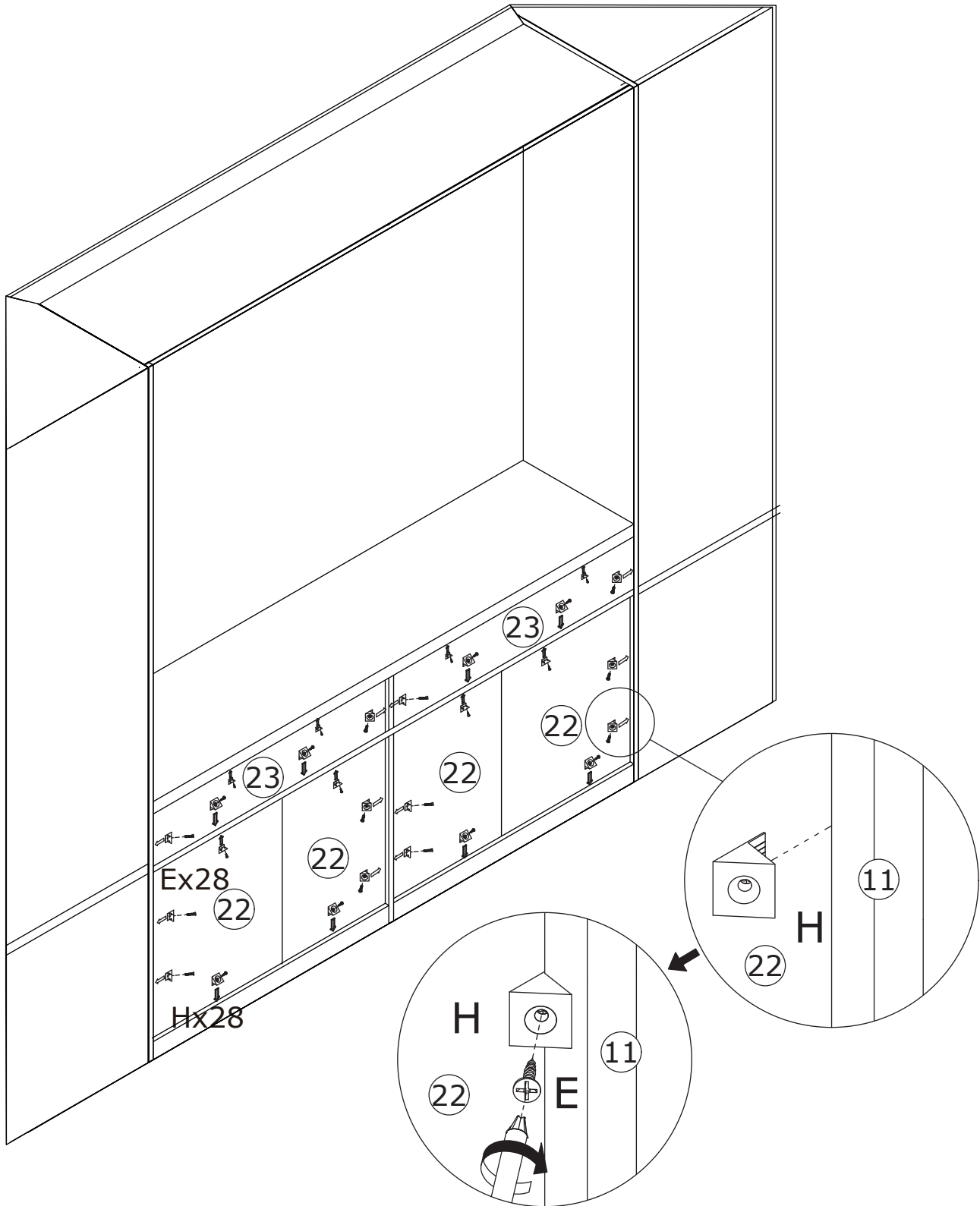

80

M x 12

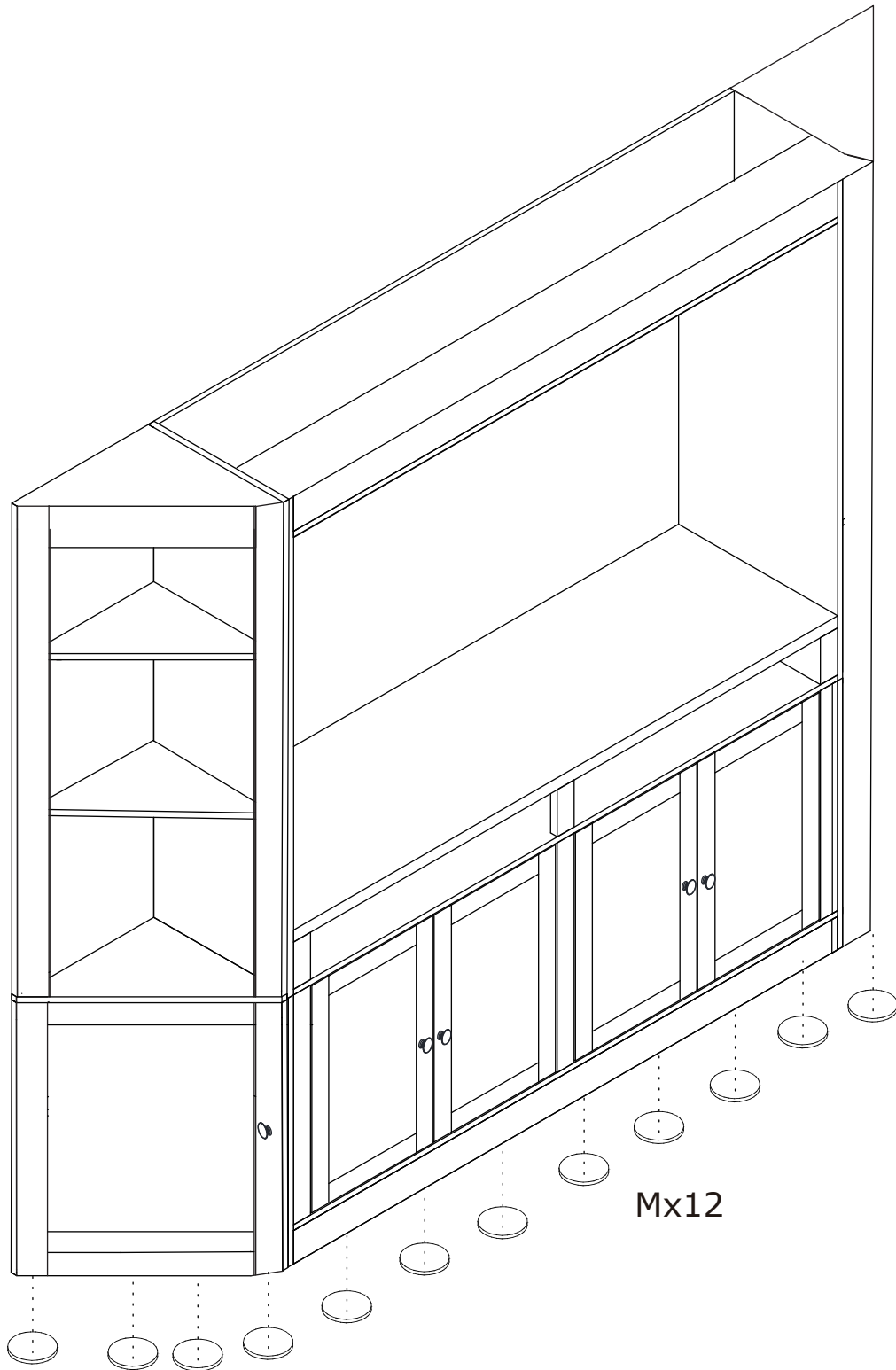

81

Q x 2

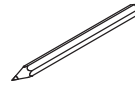
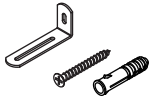

Drill holes in the wall and tap plastic parts (Q) into.
Secure metal part (Q) to the plastic part.

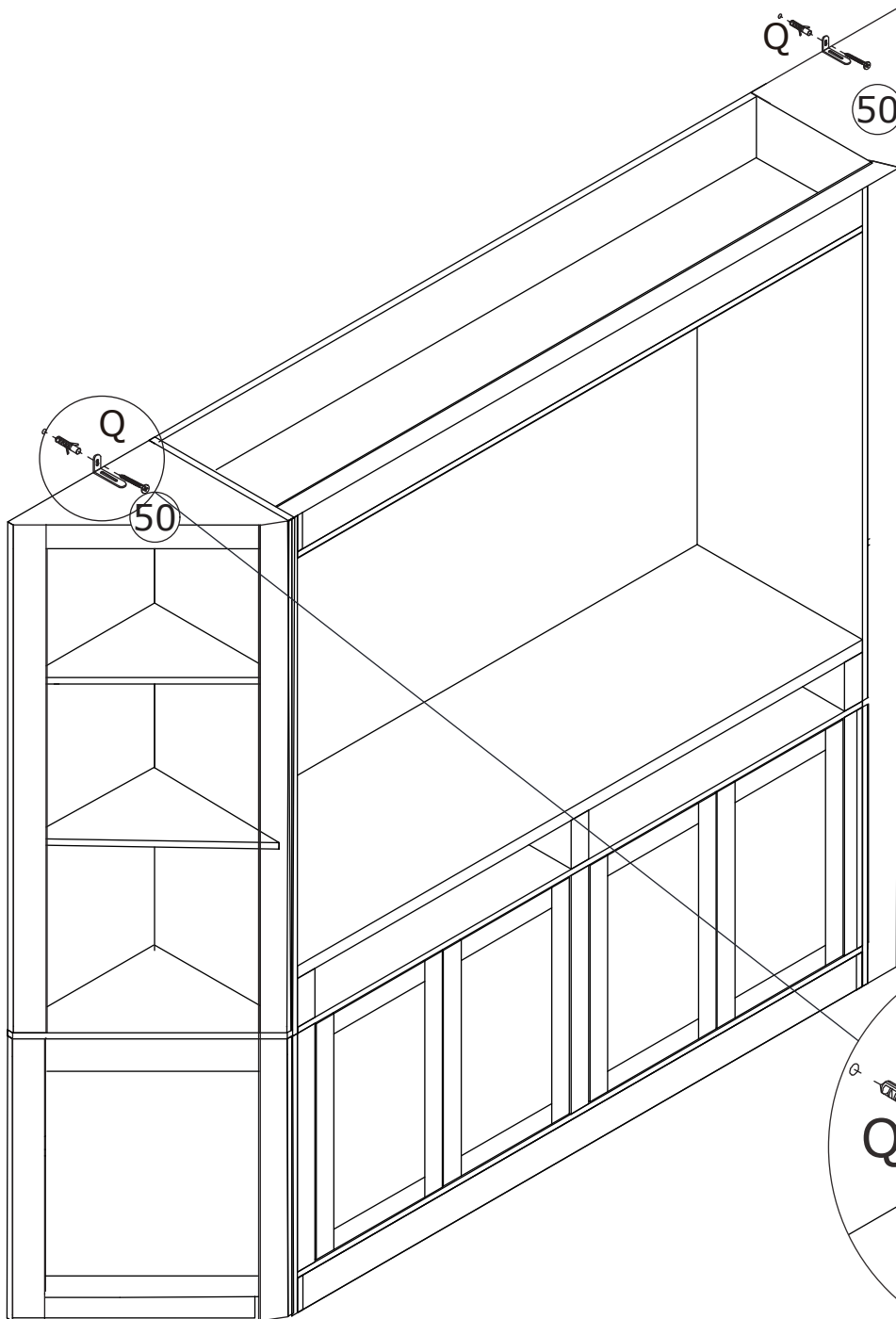

1.

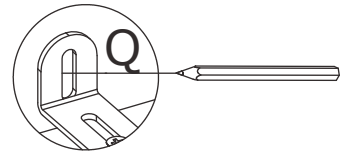

2.

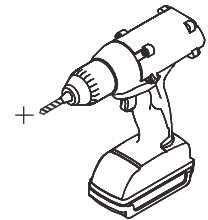

3.

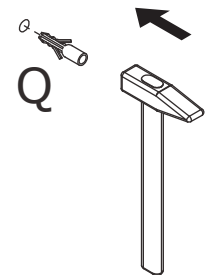

4.

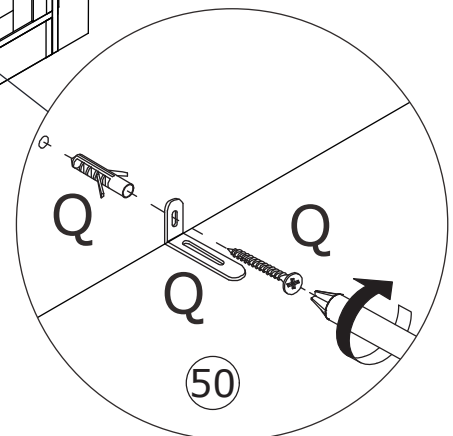
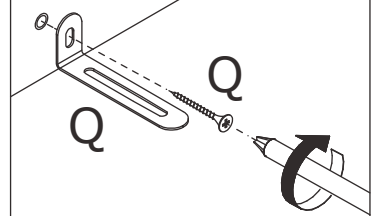

82

Q x 2

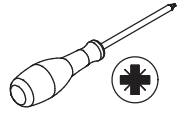

Secure cabinet to the metal part (Q).

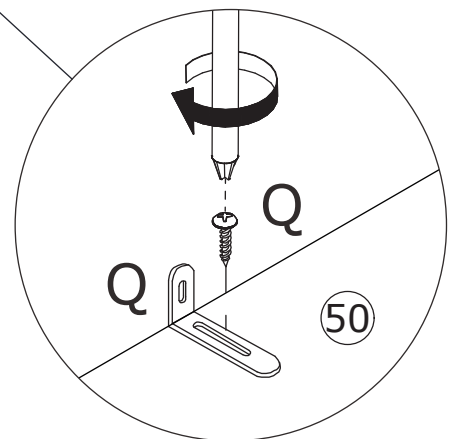
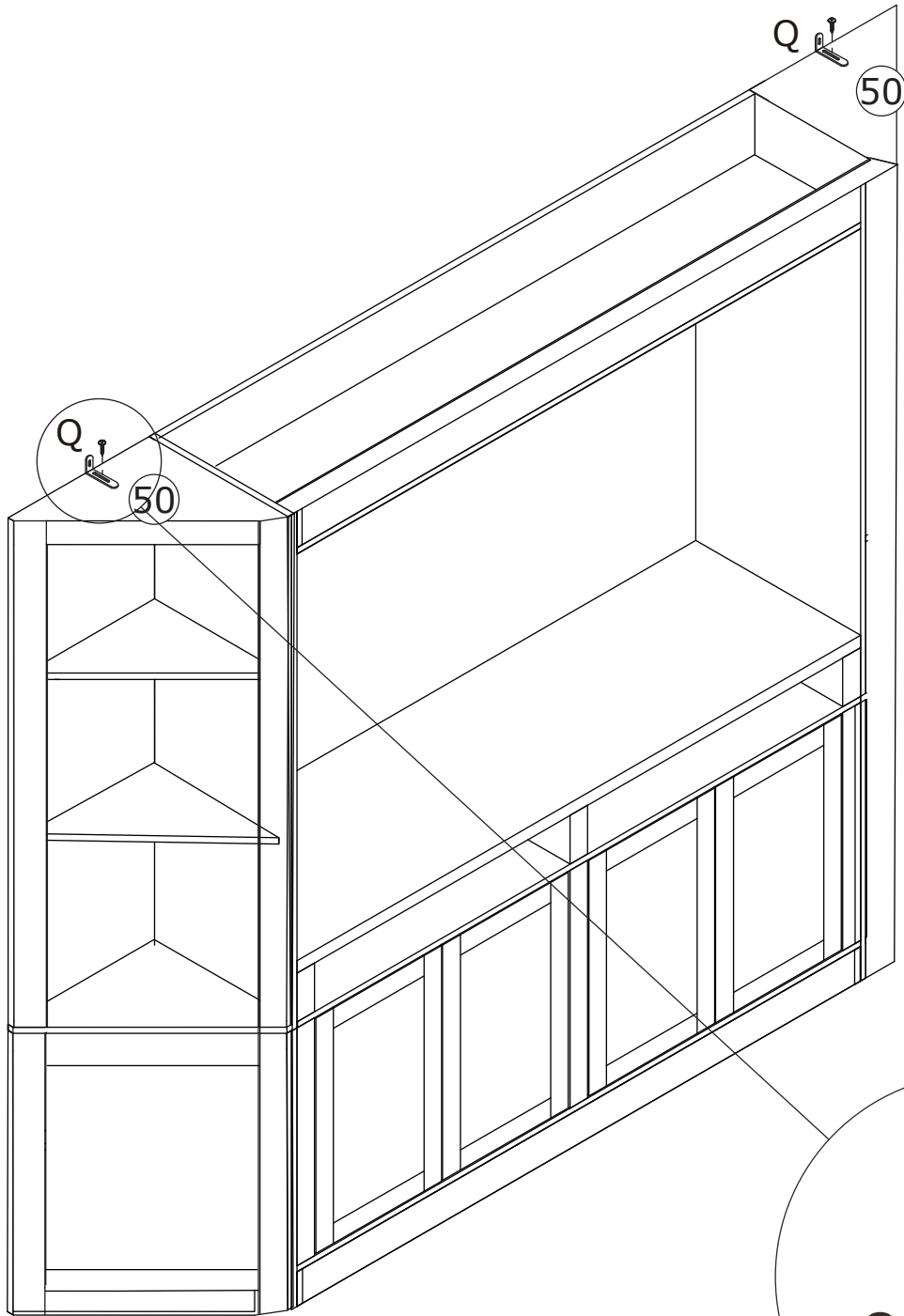

83

K x 182+5

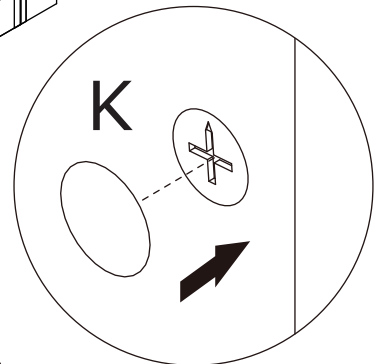
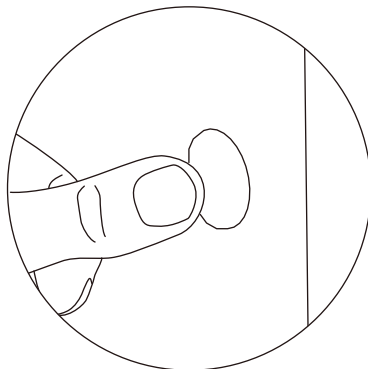
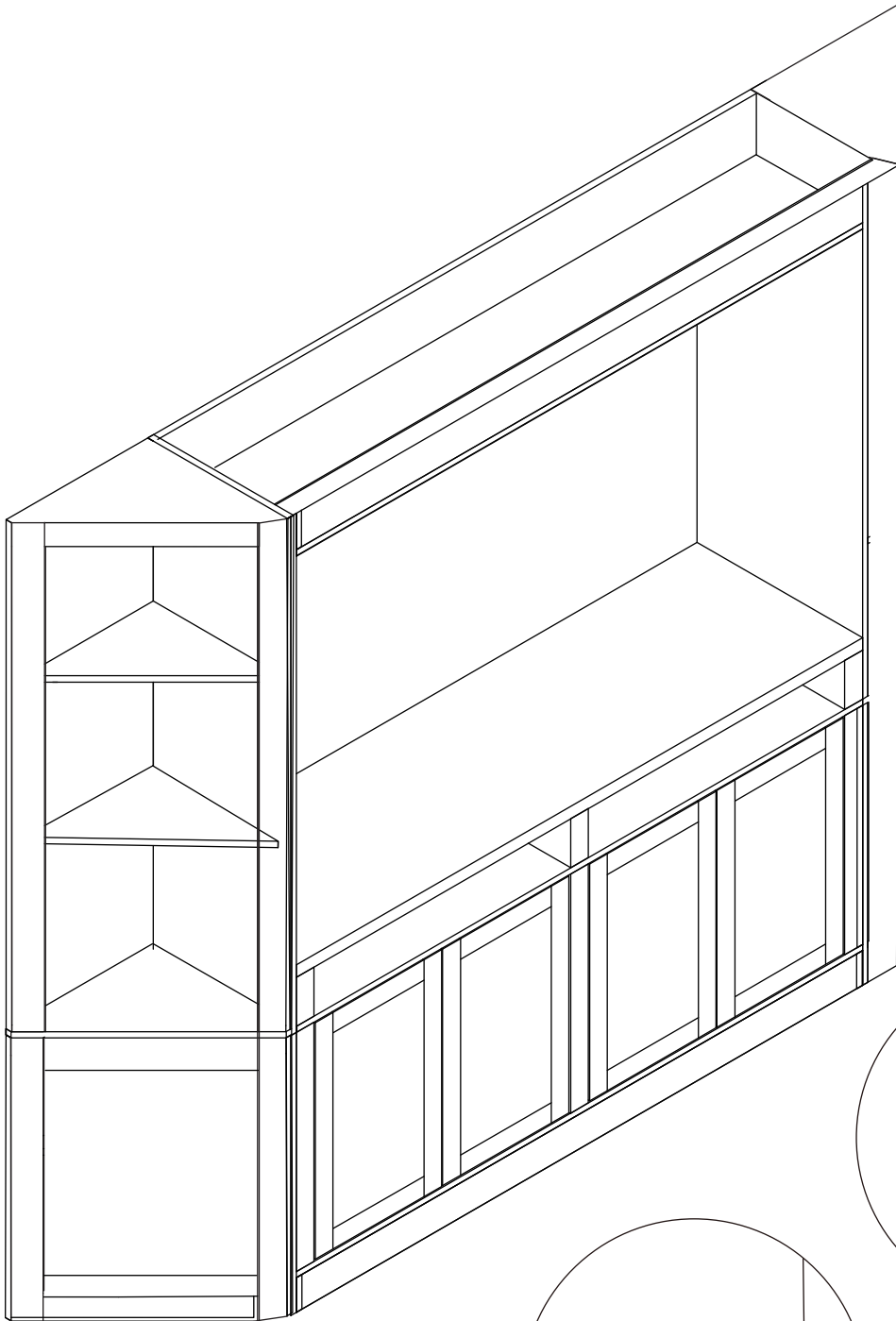

WARRANTY

WARRANTY CLAIMS

- There is a 30-day warranty for broken furniture or any other problems that do not work properly. The warranty will start from the date of purchase which must be verified by proof of purchase.
- Before making a claim, we may be able to answer your query, simply call us. Please leave your purchase order number, along with some details of the problem, if you want a replacement part. We will arrange within 48 hours. If there is out of stock, we will reply with a shipping date.
- The product must be used in accordance with the instructions provided. For health reasons.
- For other reasons, if the furniture needs to be returned, it must be cleaned and dried and operated within 30 days of receipt.

Type of Warranty Claim

- Failure to follow the furniture instructions will invalidate the warranty. Attention please.
- Does not include damage during installation, but includes damage during transportation.

Scope of responsibility

- Shall not bear any responsibility for misuse or user damage and / or loss of parts during the installation of furniture.
- After using, the damage and scratches of the furniture are not covered by the warranty.

The Warranty Relates to All Bought in The Us and Covers The Following Areas

- Sheet parts: 1 month from the date of purchase.
- Electrical parts: 1 month from the date of purchase.

RETURNS

CHANGED YOUR MIND AND NEED TO RETURN YOU ITEM?

PLEASE FOLLOW THE BELOW INSTRUCTIONS:

- If you have purchased and have simply changed your mind, follow the retailer's instructions for returns.

DEFECTIVE ITEMS

- If your item is defective in any way, i.e. it doesn't work but you can't identify why, in the first instance, please call us.

DAMAGED ITEMS

- If you receive an order with obvious shipping damage from the retailer, then we suggest the delivery is refused. If the delivery has been accepted and then shipping damage is found, please follow the specific instructions advised by the retailer.
In all circumstances please save all packaging material and paperwork for the order. Please be aware that if you dispose of packaging material or attempt to return the merchandise without contacting the fulfiller, you jeopardise your chances of making a claim, and you may not receive a credit for the return.

AFTER-SALES CONTACT



adelahu@fufugaga.com



208-820-0068