

ASSEMBLY INSTRUCTIONS

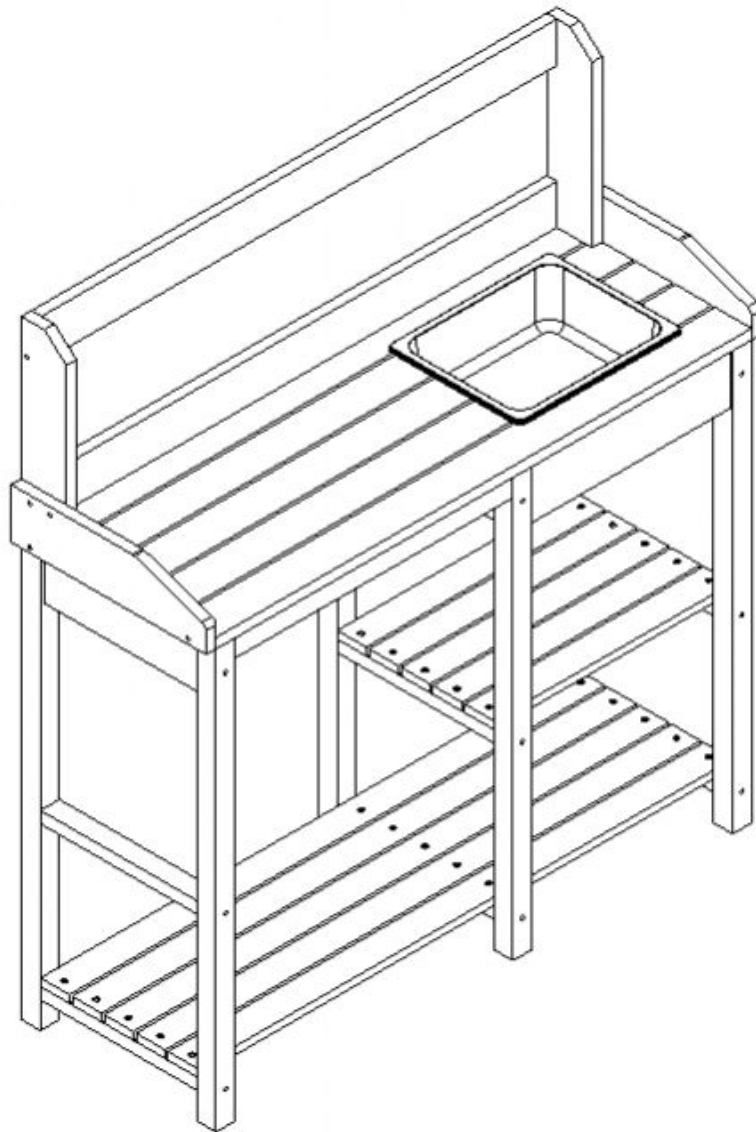

***THIS ASSEMBLY MANUAL CONTAINS IMPORTANT SAFETY INFORMATION.
PLEASE READ AND KEEP FOR FUTURE REFERENCE.***

Important Safety Information

- *Please read all instructions carefully before assembling this furniture.*
- *For your safety, assembly by two or more adults is strongly recommended.*
- *Use only vendor-supplied hardware to assemble this item. Using unauthorized hardware could jeopardize the structural integrity of the item.*
- *Hardware may loosen overtime. Periodically check that all connections are tight.*

Before Assembly

- *Remove all parts and hardware from the box. Place all items on a carpeted or scratch-free work surface, as this will avoid damaging parts during assembly.*
- *The shipping box provides an ideal work surface.*
- *To avoid accidentally discarding small parts or hardware, do not dispose of any packaging or contents of the shipping carton until assembly is complete.*
- *Use the parts and hardware lists below to identify and separate each of the pieces included.*
- *The use of power tools for assembly is not recommended. Power tools can damage the hardware and/or split the material.*
- **Note:** *Do not fully tighten all bolts until all parts are in place. Failure to follow these instructions may cause the bolts to misalign during assembly.*

Care and Cleaning

- *Routine cleaning of the furniture can be completed with only warm water and soap.*
- *You can use the sanding sponge for cleaning.*

Components

A	On the back horizontal	2
B	Right side plate	1
C	Left medial plate	1
D	Lateral plate	2
E	Frame	1
F	Layer frame	1
G	Bottom frame	1
H	Pull	1
I	Feet	6

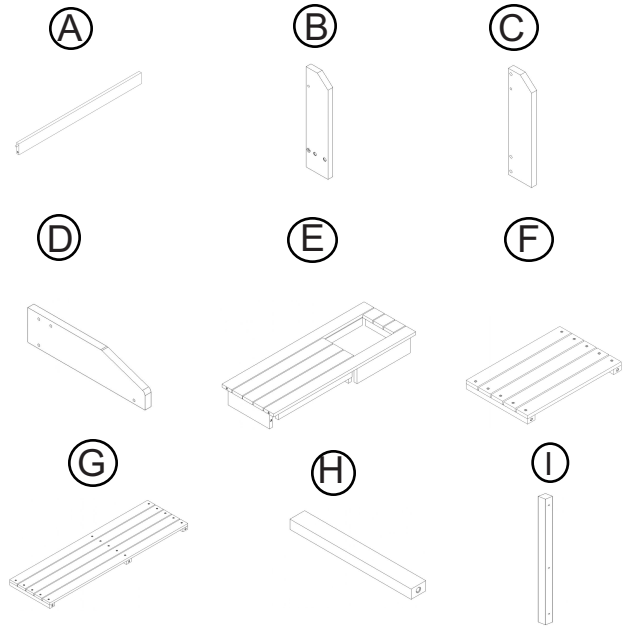

Hardware

(J)
M6*35MM Bolt
Qty: 12

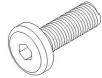

(K)
M6*55MM Bolt
Qty: 18



(L)
Pots
Qty: 1

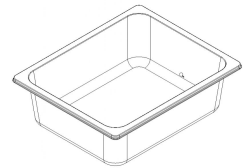

Sanding Sponge for Cleaning



Tools Needed for Assembly



Allen key

Step 1

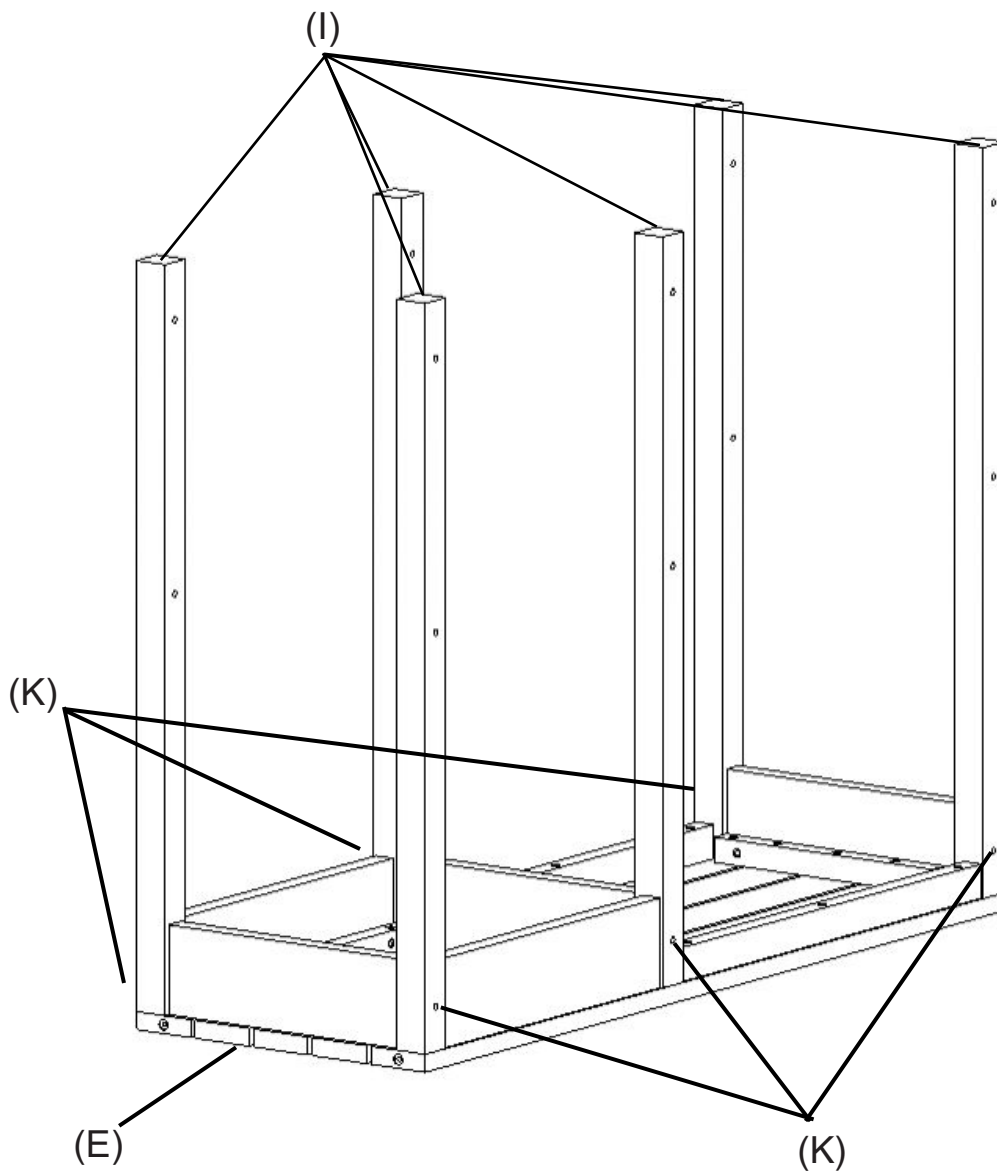
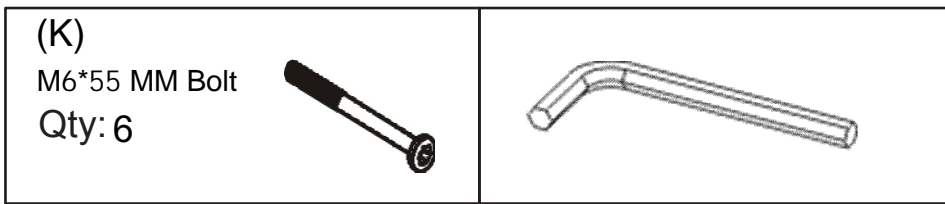

The face frame (E) is fixed with the foot (I)

Secure with bolt (K) x6

Step 2

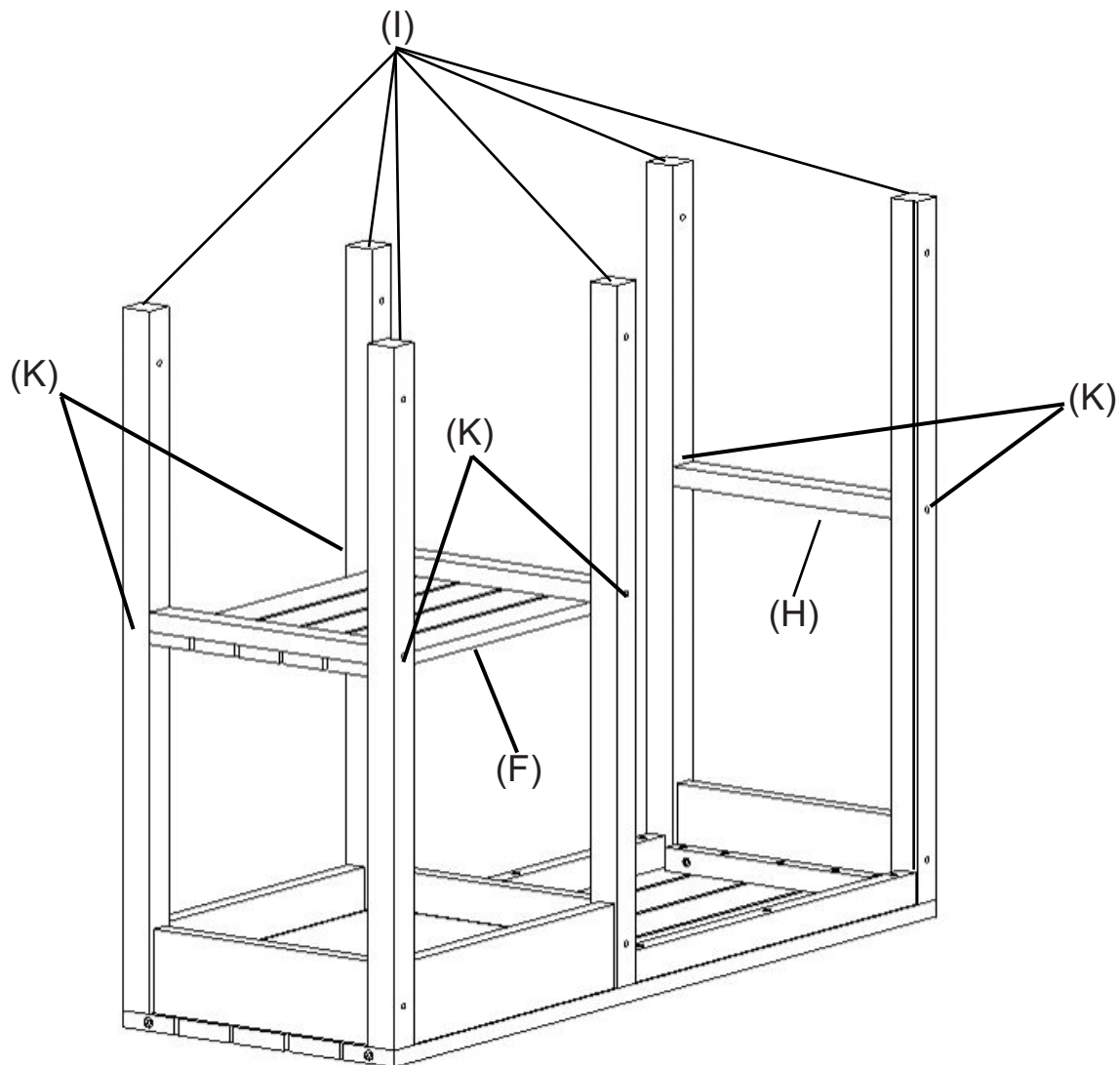
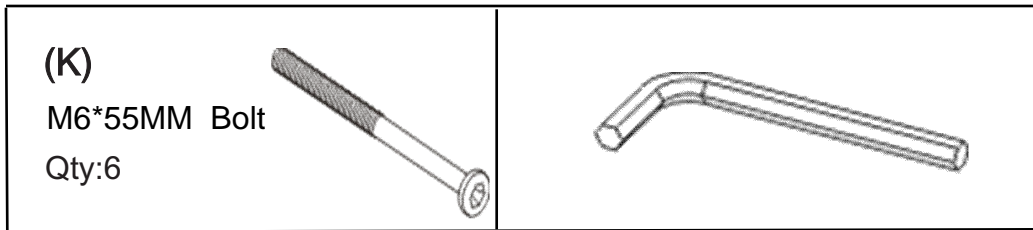

The foot (I) is fixed with the layer frame (F)

The foot (I) is fixed with the pulling bar (H)

Secure with bolt (K) x6

Step 3

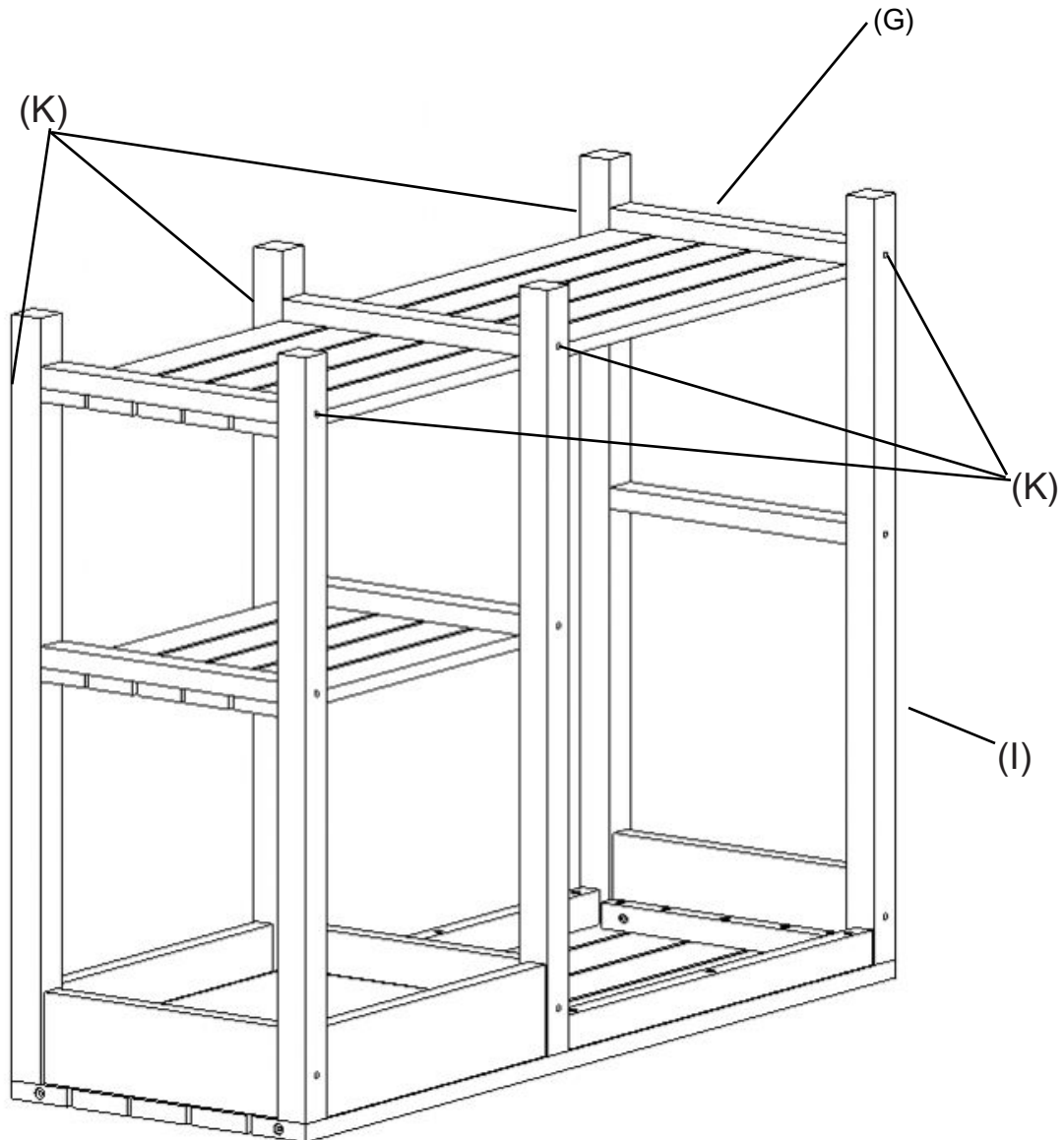
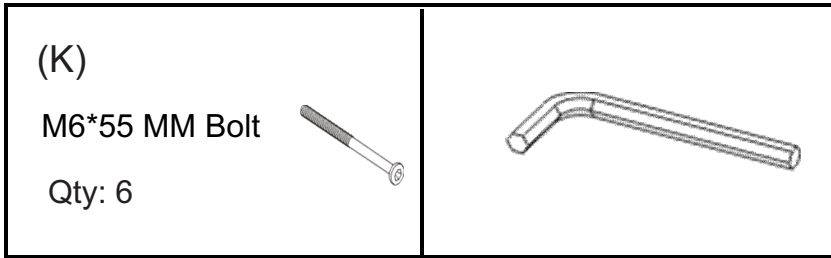

The foot (I) is fixed with the bottom plate (G)

Secure with bolt (K) x6

Step 4

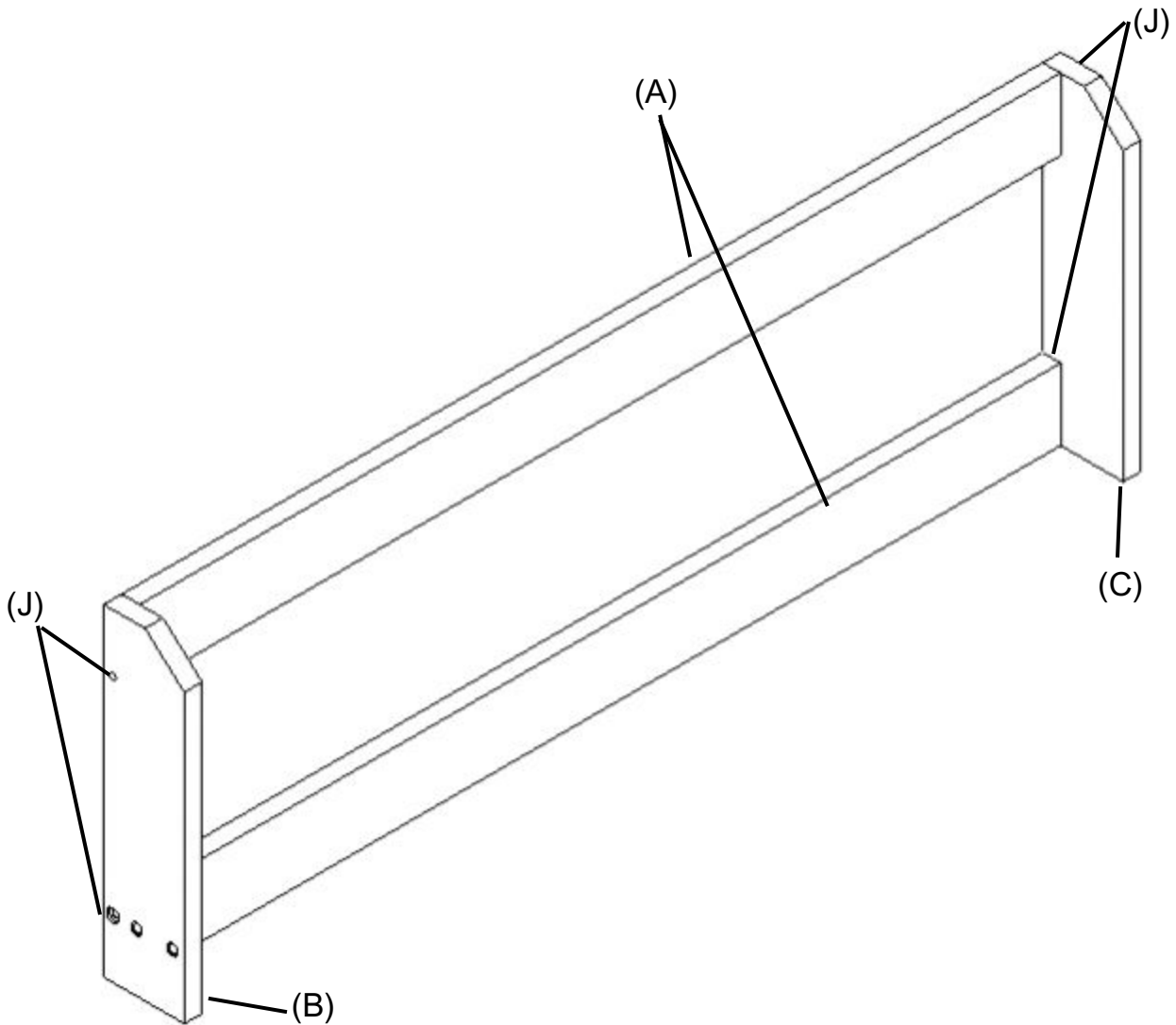
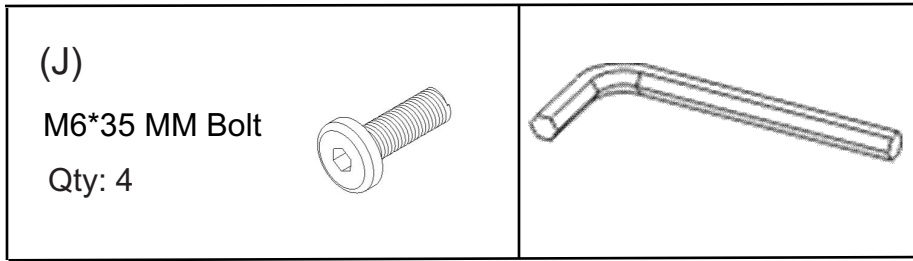

Posterior superior transverse (A) was fixed with medial plate (B.C)

Secure with bolt (J) x4

Step 5

(J)
M6*35 MM Bolt
Qty: 8

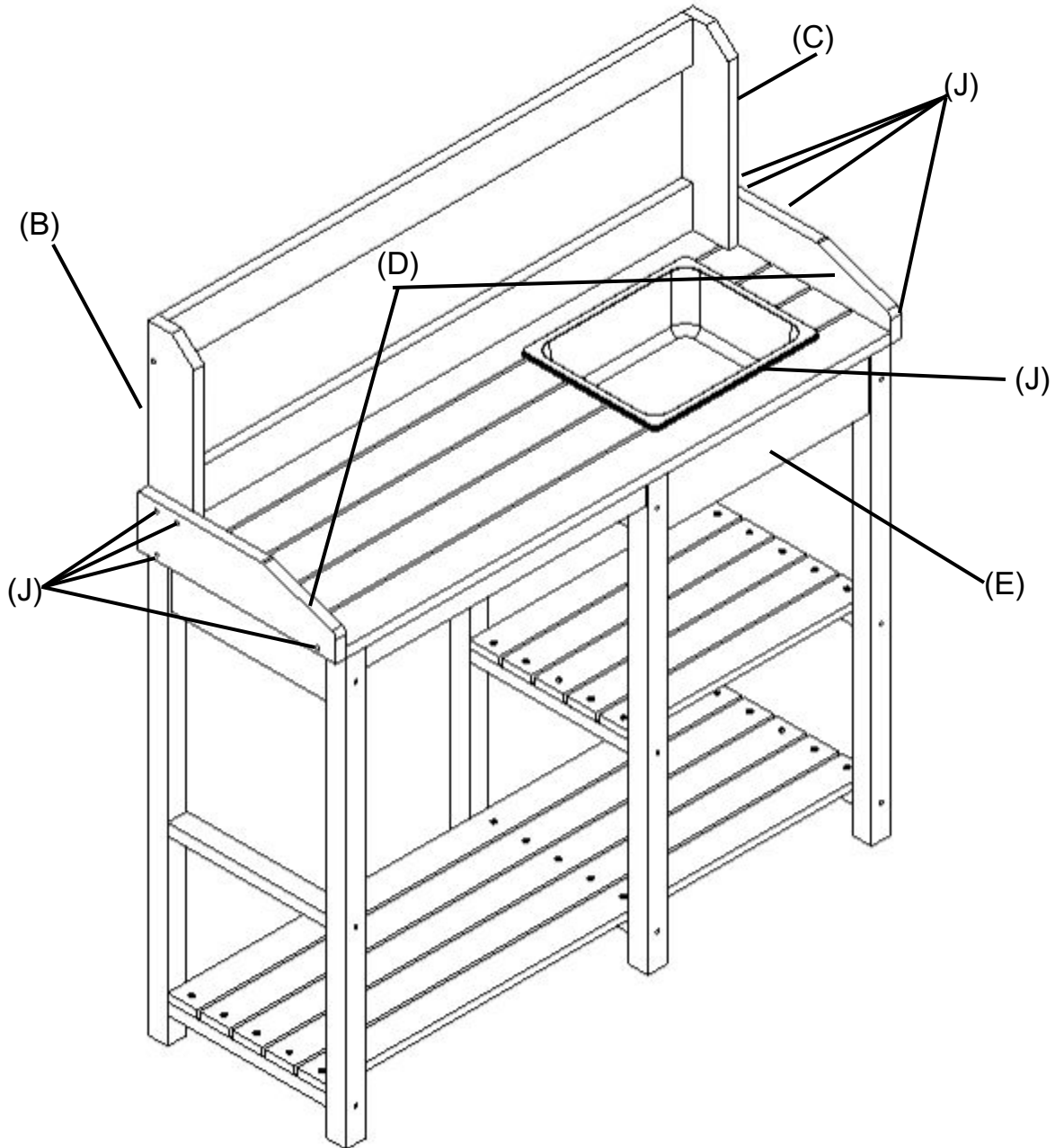
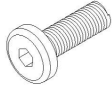

The lateral plate (D) is fixed with the medial plate (B C) face frame (F)
Secure with bolt (J) x8