

10-DRAWER STORAGE CHEST
10-SCHUBLADEN-KOMMODE
COFFRE DE RANGEMENT À 10 TIROIRS
10-CASSETTI CASSETTIERA
10-CÓMODA DE ALMACENAMIENTO

EN

 Attention: For safety and stability, we suggest you have to secure the anti-tip accessories to the wall to prevent tipping, injury, and property damage.

Attention:

1. Periodically check that all components are tightly secured.
2. Assemble on a flat, clean, and soft surface.
3. Confirm all parts are present prior to assembly.
4. Prepare electric tools in advance for a quicker installation.

DE

Achtung: Aus Sicherheits- und Stabilitätsgründen empfehlen wir, das Anti-Kipp-Zubehör an der Wand zu befestigen, um Kippen, Verletzungen und Sachschäden zu vermeiden.

Achtung:

1. Prüfen Sie regelmäßig, ob alle Komponenten fest sitzen.
2. Montieren Sie das Gerät auf einer ebenen, sauberen und weichen Oberfläche.
3. Vergewissern Sie sich vor dem Zusammenbau, dass alle Teile vorhanden sind.
4. Bereiten Sie Elektrowerkzeuge im Voraus vor, um eine schnellere Installation zu ermöglichen.

FR

Attention: Pour plus de sécurité et de stabilité, nous vous recommandons de fixer l'attache de pointe au mur pour éviter le déversement, les dommages et les dommages matériels.

Attention:

1. Vérifiez périodiquement que tous les composants sont bien fixés.
2. Assemblez le tout sur une surface plane, propre et douce.
3. Confirmez que toutes les pièces sont présentes avant l'assemblage.
4. Préparez les outils électriques à l'avance pour une installation plus rapide.

IT

Attenzione: Per assicurare sicurezza e stabilità, ti consigliamo di fissare al muro gli accessori anti-ribaltamento per prevenire rovesciamenti, lesioni o danni ai beni.

Attenzione:











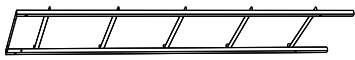
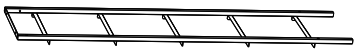
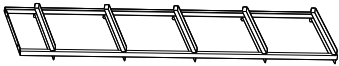

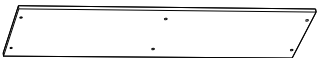

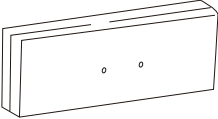
1. Controllare periodicamente che tutti i componenti siano fissati saldamente.
2. Assemblare su una superficie piana, pulita e morbida.
3. Assicurarsi che siano presenti tutte le parti prima dell'assemblaggio.
4. Preparare gli strumenti elettrici in anticipo per un'installazione più veloce.

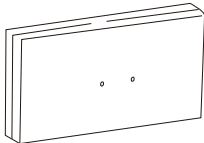
ES

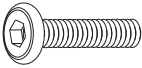

Atención: Por seguridad y estabilidad, le sugerimos que coloque los accesorios de fijación a la pared para evitar vuelcos, lesiones y daños a su propiedad.

Atención:

1. Revise que todos los componentes estén asegurados con regularidad.
2. Monte sobre una superficie que sea plana, limpia y suave.
3. Antes de montar el producto, revise que tenga todas las piezas a mano.
4. Para facilitar la instalación, prepare las herramientas eléctricas necesarias con tiempo.

Item no. Nr. N° d'article Articolo No. Artículo No.	Reference Image Referenzbild Image de référence Immagine di riferimento Imagen de referencia	Qty. Menge Qté. Qtà Cant.	Item no. Nr. N° d'article Articolo No. Artículo No.	Reference Image Referenzbild Image de référence Immagine di riferimento Imagen de referencia	Qty. Menge Qté. Qtà Cant.
A		X1	B		X1
C		X1	D		X2
E		X2	F		X1
G		X1	H		X2
I		X2	J		X10
K		X8	1		X1
2	 M6X25mm	X6	3	 M6X10mm	X6
4	 M5X10mm	X8	5	 M4X12mm	X10
6	 M4X60mm	X2	7		X2
8		X4			

1

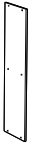
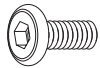
-  **A** 1pc
-  **B** 1pc
-  **C** 1pc
-  **F** 1pc
-  **3** 6pcs

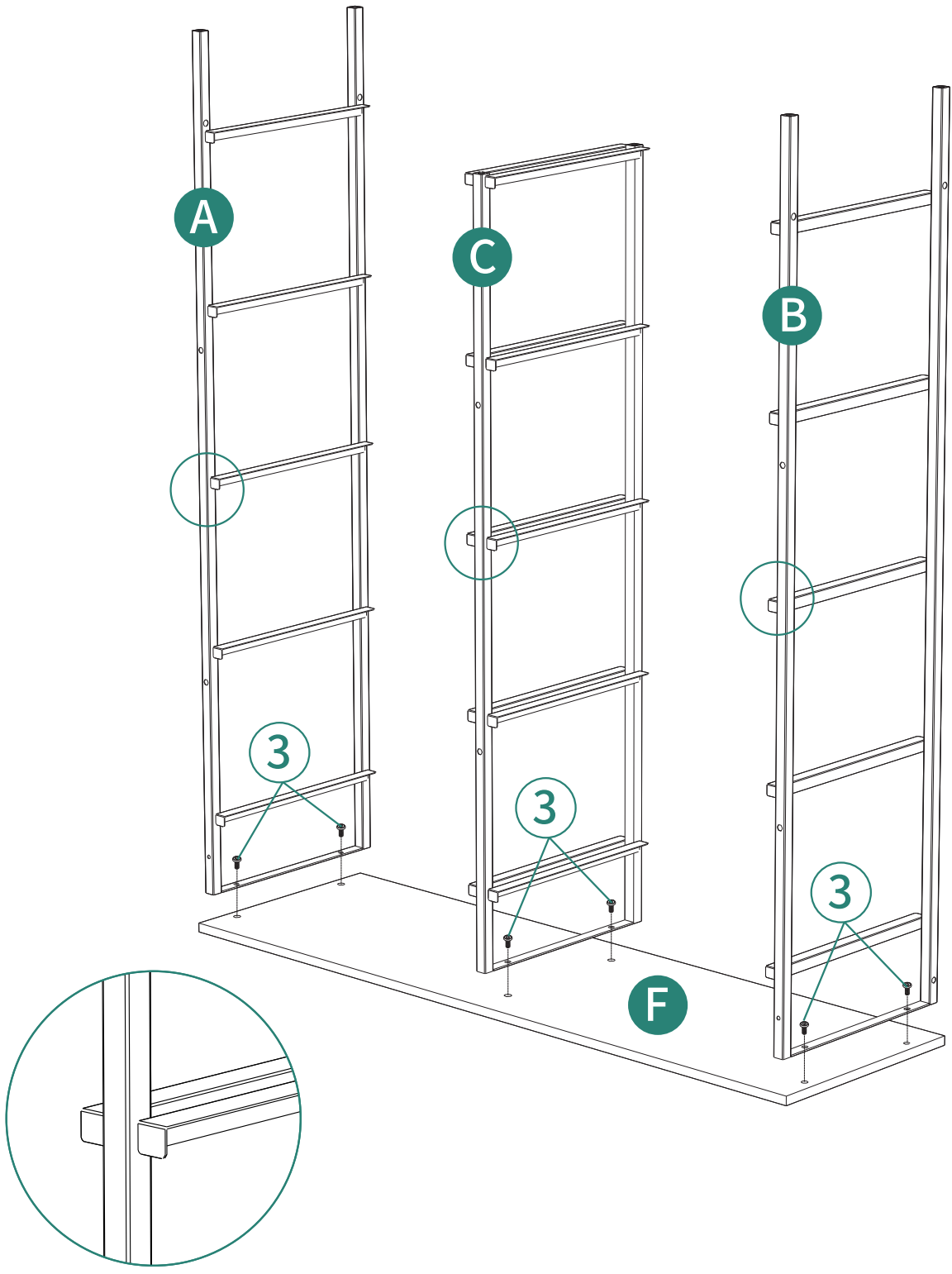

2



ⓔ 2pcs ② 6pcs

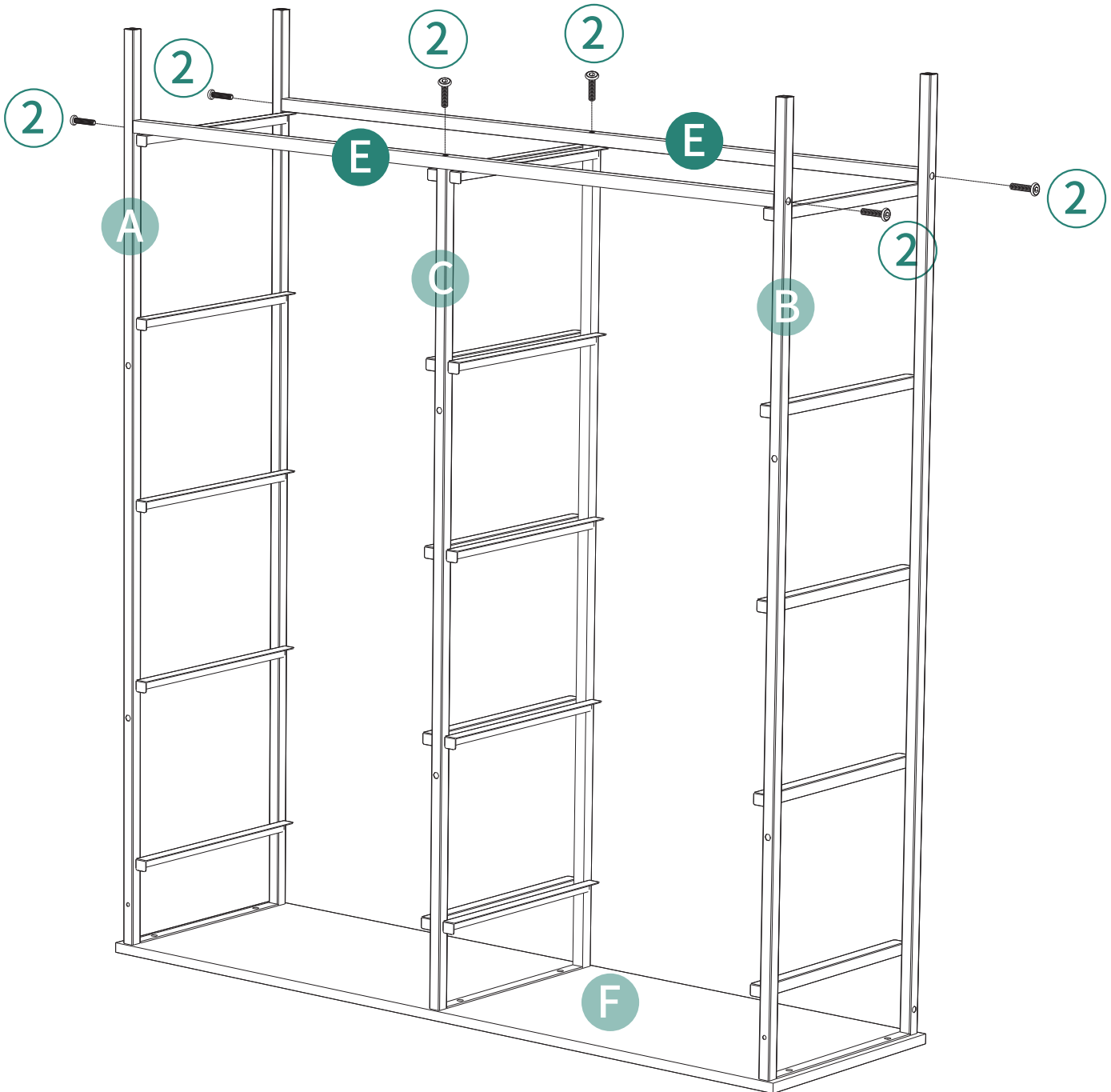

3

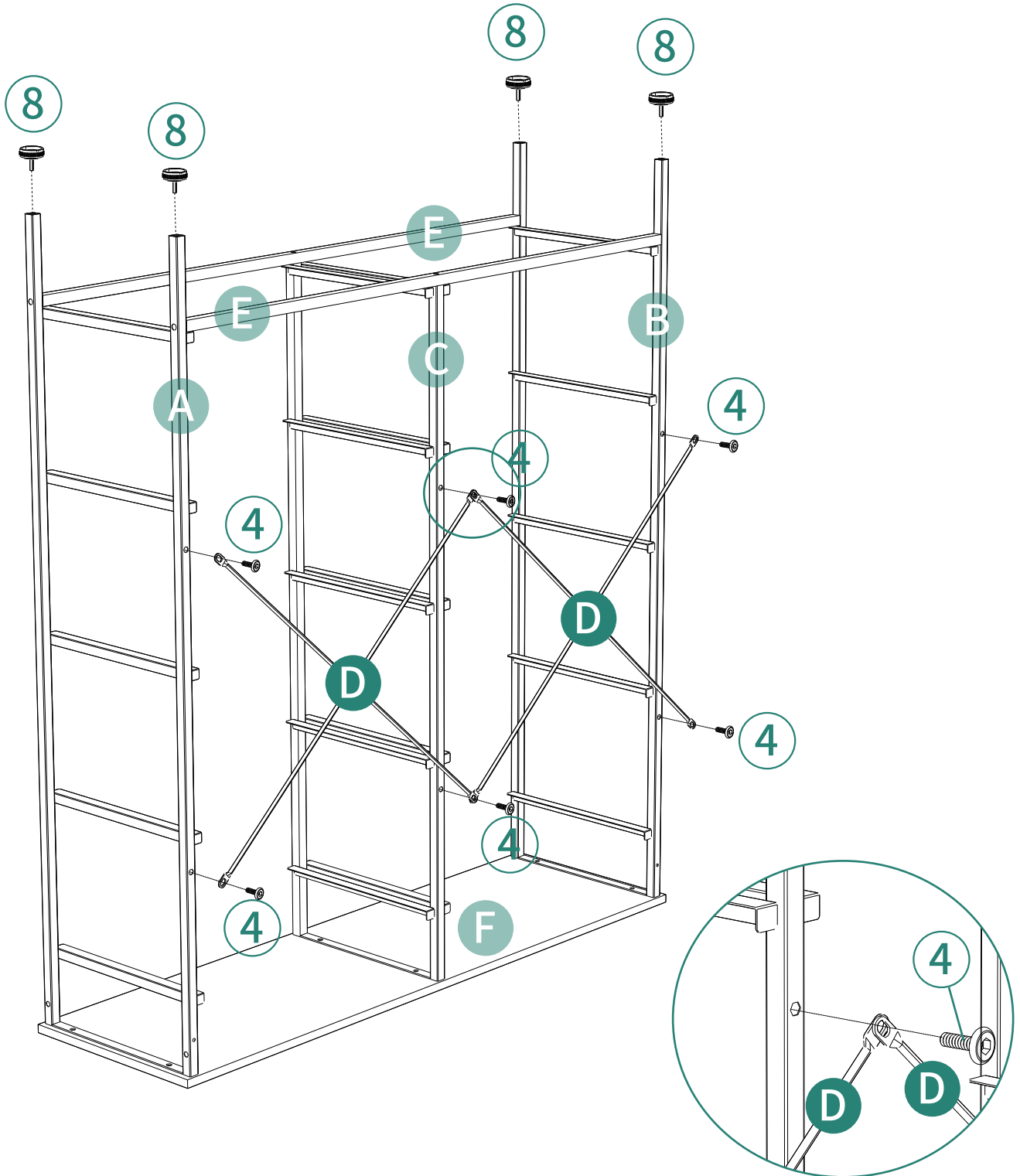
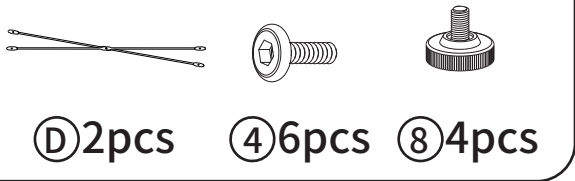

4

X2

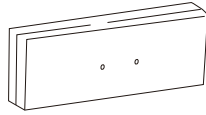

ⓐ 2pcs



ⓑ 2pcs



Ⓒ 2pcs



Ⓓ 2pcs

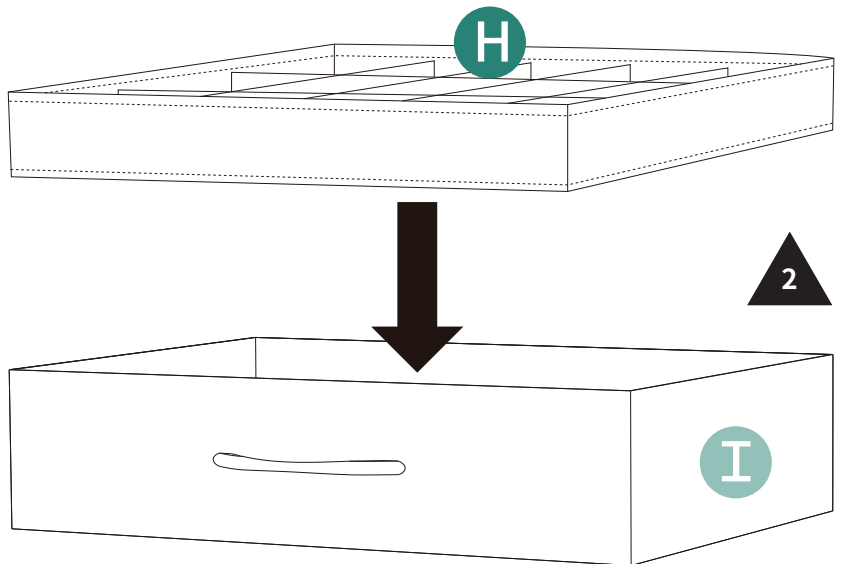
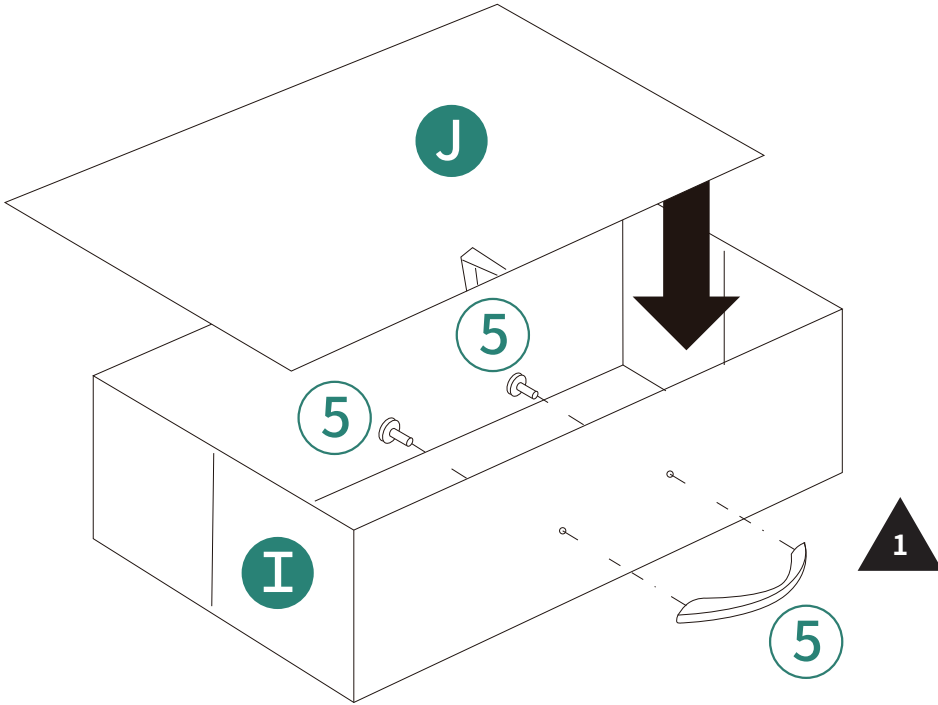

5
X8

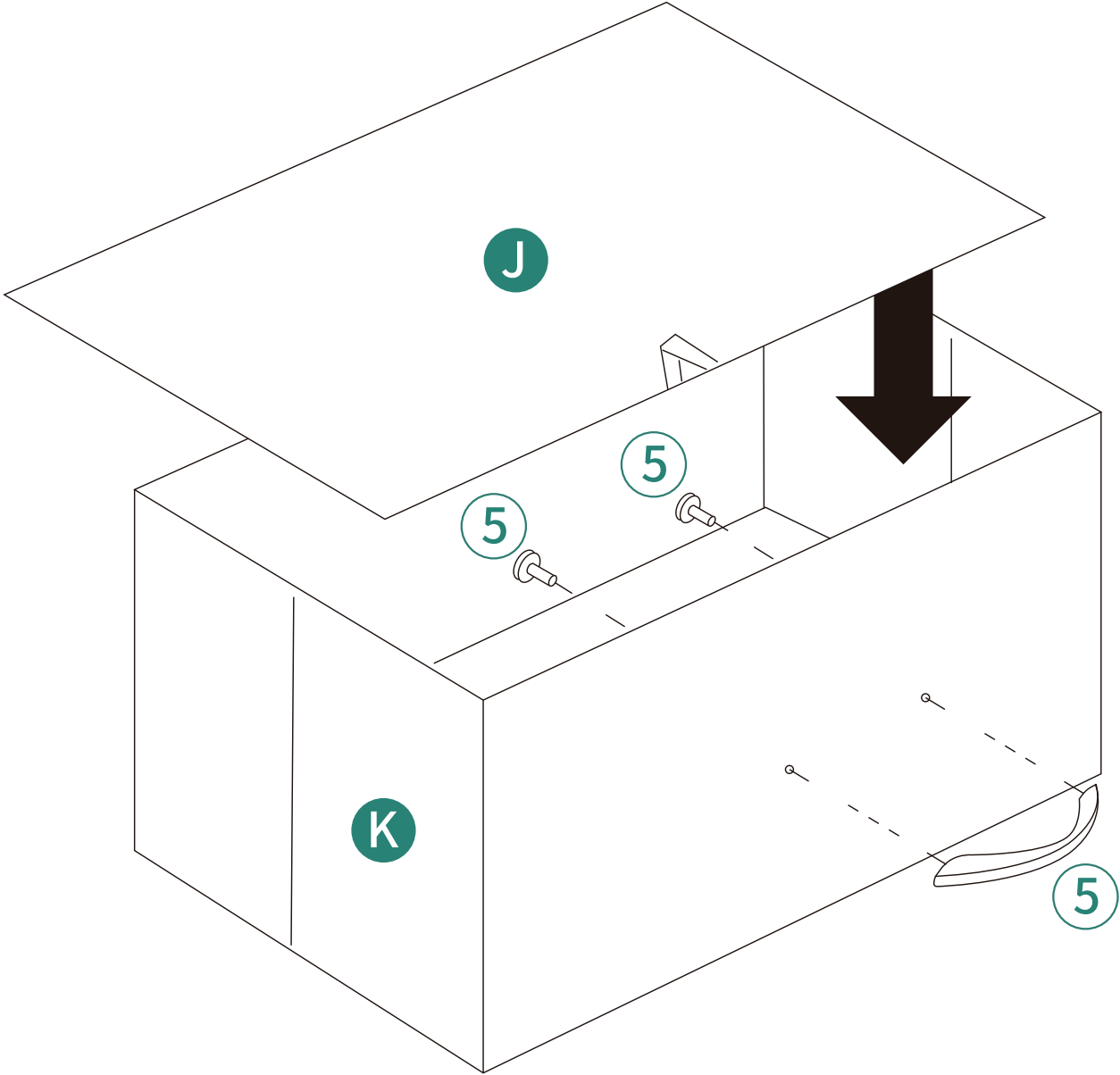
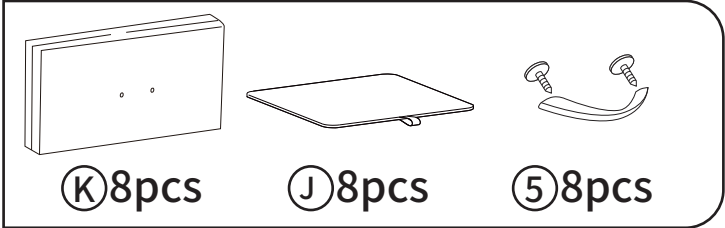

6

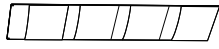

ⓐ 1pc



④ 2pcs

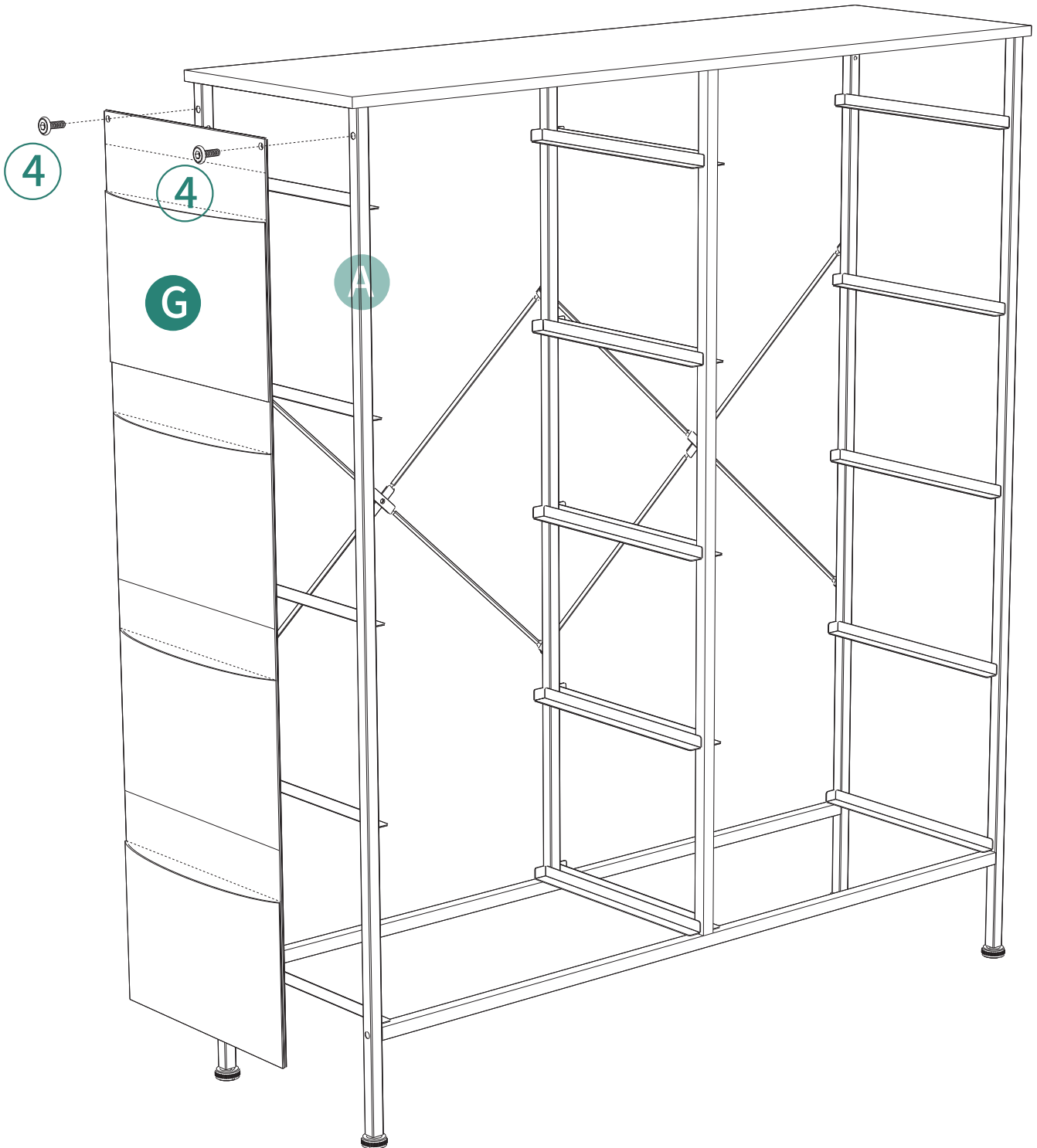

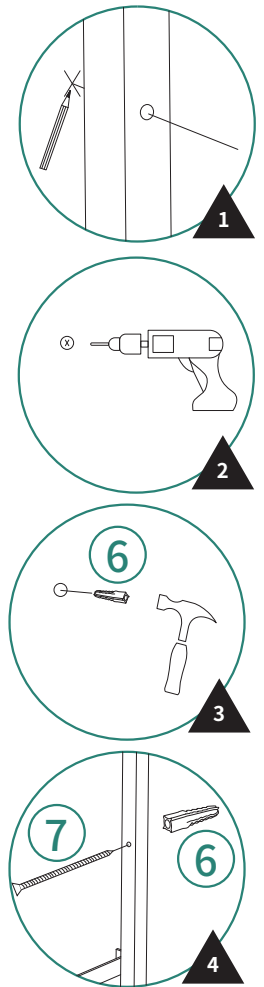
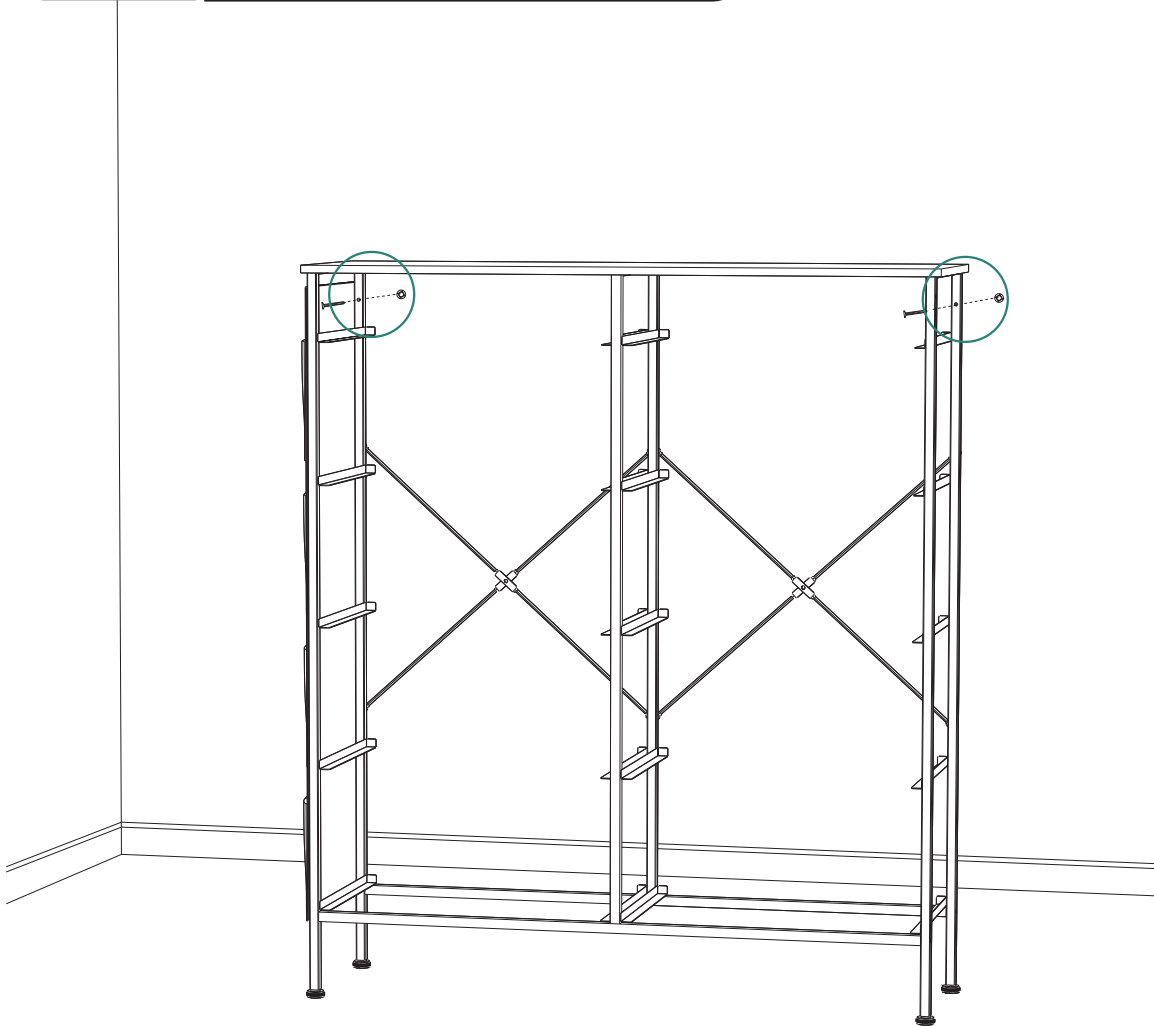
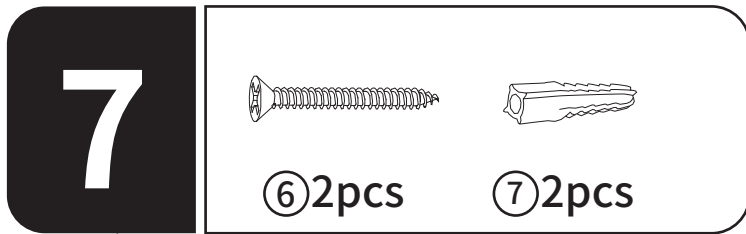

Fixing the fabric dresser to the wall is recommended.
Please follow the instructions.

Es wird empfohlen, die Stoffkommode an der Wand zu befestigen.
Bitte befolgen Sie die Anweisungen.

Il est recommandé de fixer la commode en tissu au mur.
Veuillez suivre les instructions.

Si consiglia di fissare il comò in tessuto alla parete.
Seguire le istruzioni.

Se recomienda fijar la cómoda de tela a la pared.
Por favor, siga las instrucciones.

8

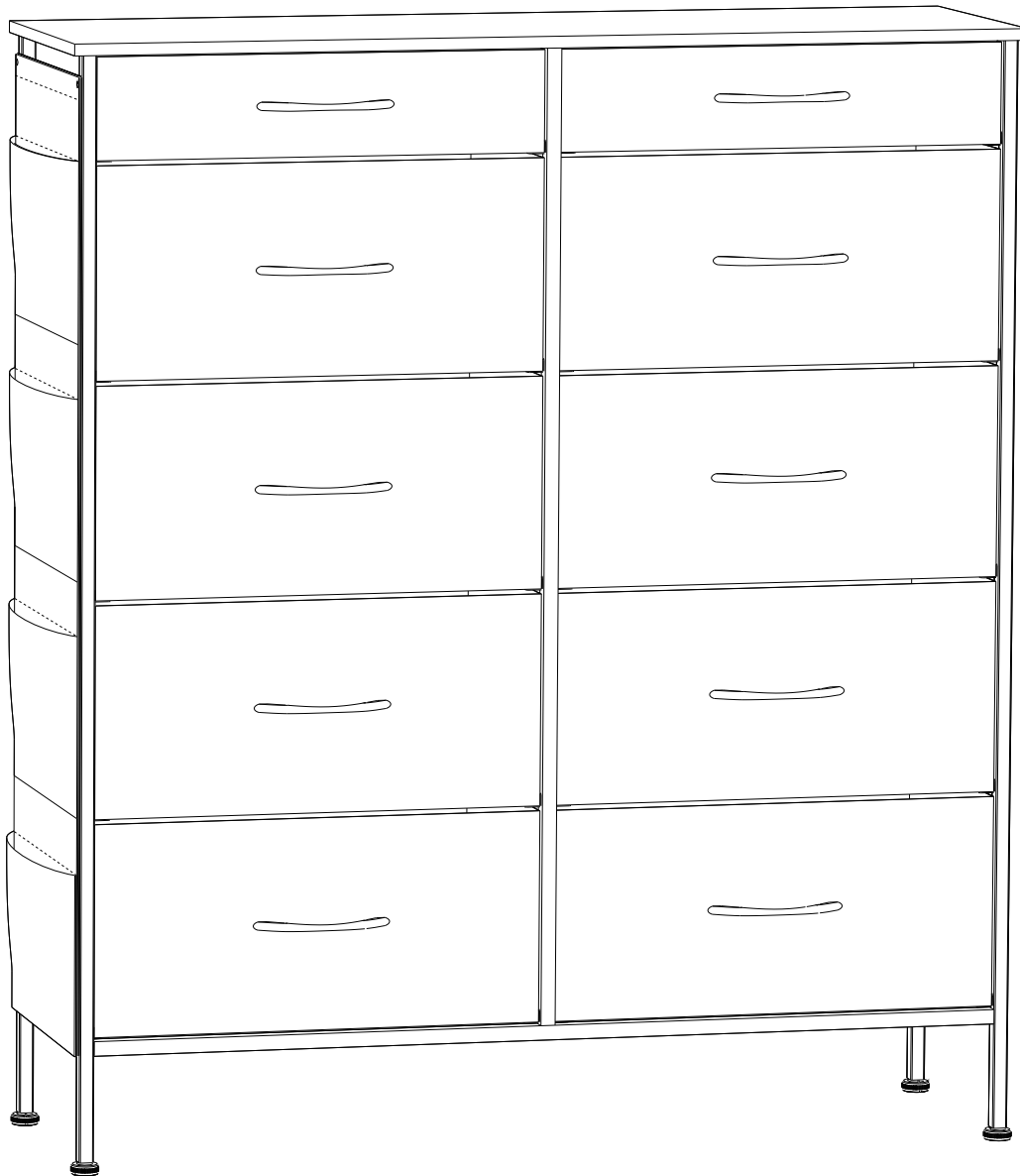

Installation Completed

Installation Abgeschlossen

Installation Complétée

Installazione Completata

Instalación Completada