

OWNER MANUAL

ATTENTION

Attention Customers living in the United States and Canada

If you are missing parts, hardware, or if your product has been damaged during shipping

DO NOT RETURN YOUR PRODUCT

The store does not stock parts and may not be able to help you. Please contact us directly and **we will ship you the parts** you need to your shipping address **at no cost to you**. For the quickest and most efficient service, please reach out to us

We're here to help!

※ **Stay Scratch-Free: Safeguard Your Furniture by Assembling on Carpet.**

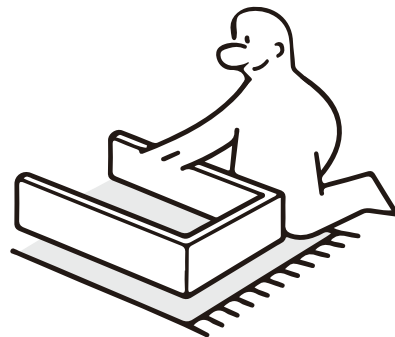
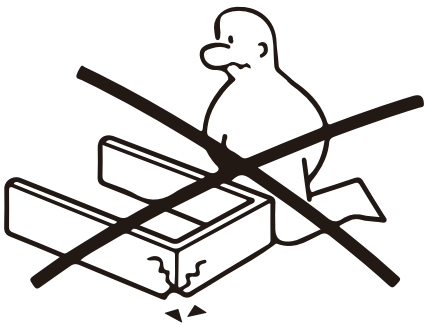

※ **Stuck in Assembly Limbo? Check out our website or contact our support team for quick solutions!**

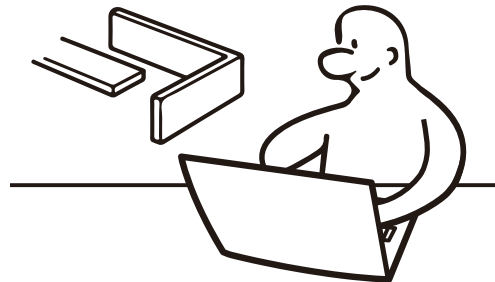
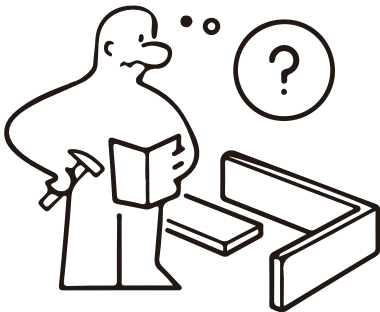

WARNING: ASSEMBLY NOTICE

Attention

Important Instructions for Assembling Your Furniture To ensure the longevity and integrity of your MDF furniture, please adhere to the following guidelines:

DO NOT USE AN ELECTRIC DRILL

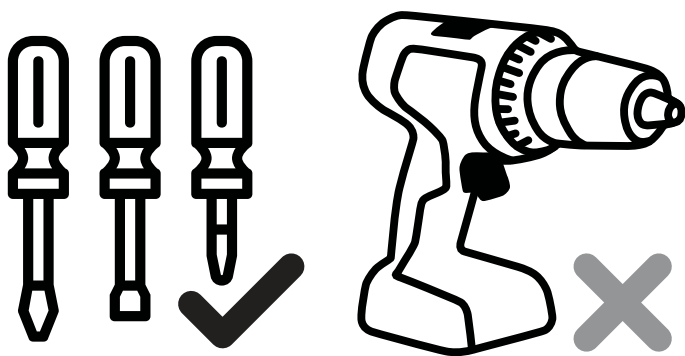

Using an electric drill can cause irreversible **damage to the MDF boards**, leading to compromised structural integrity and potential voiding of your warranty.

IF AN ELECTRIC DRILL MUST BE USED

- **Set to Lowest Torque Setting :**

Ensure your drill is set to the lowest possible torque setting to avoid over-tightening and damaging the material.

- **Proceed with Caution :**

Carefully monitor the drilling process to prevent excessive force and damage.

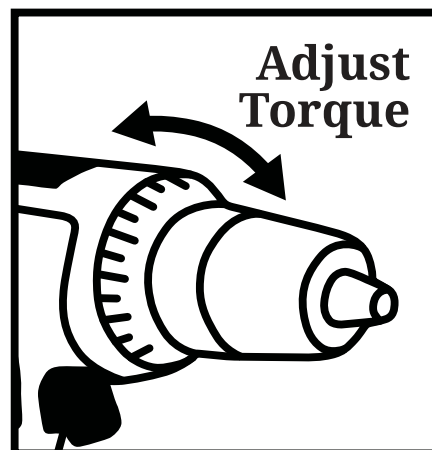

For best results and to avoid any damage, we highly recommend using the provided manual tools or a handheld screwdriver.

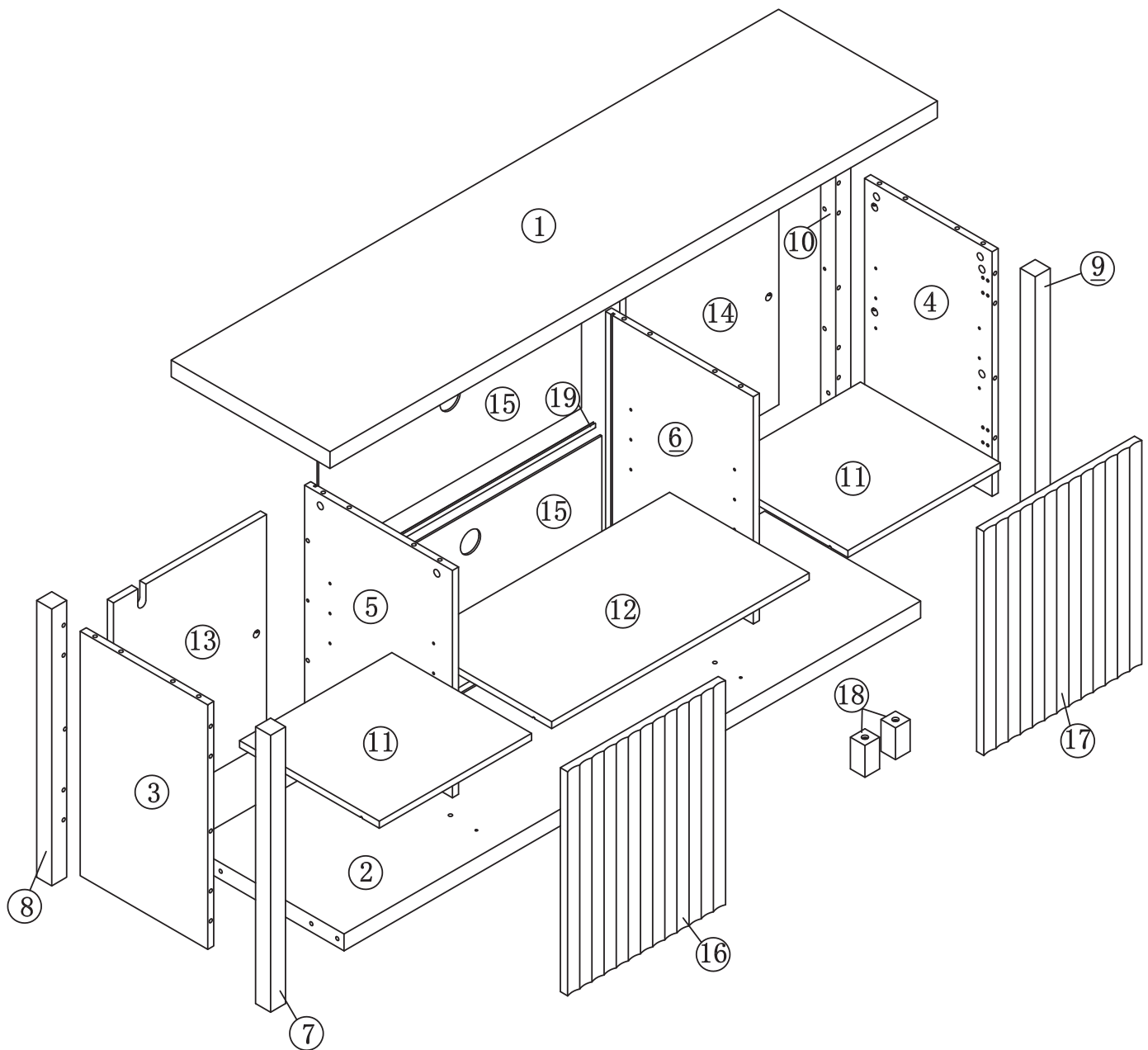

Thank you for your attention and understanding.

PARTS LIST



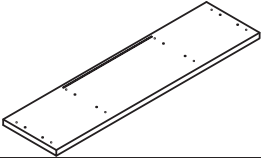
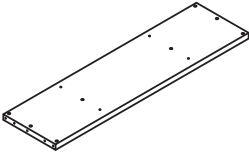
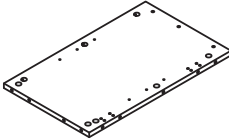
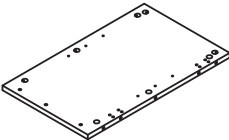
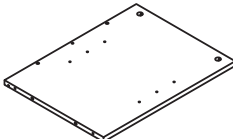
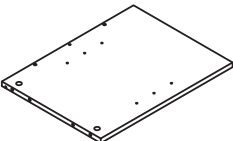
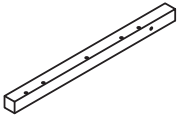
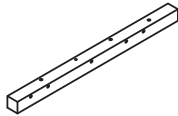
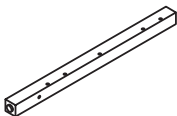
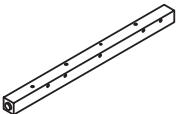

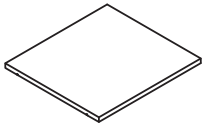
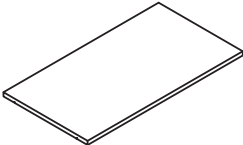
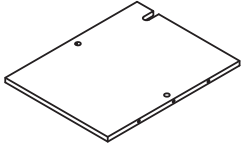
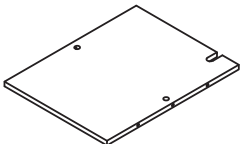
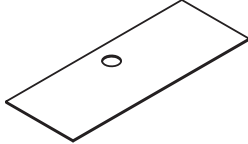
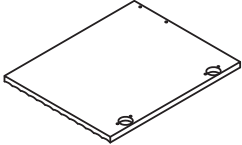
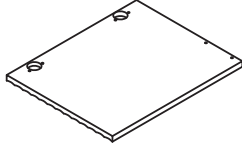

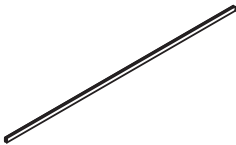



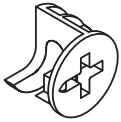
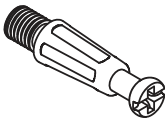
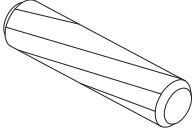
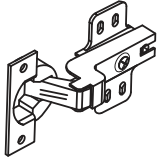

PARTS LIST

Item	Reference Image	Qty
1		x1
2		x1
3		x1
4		x1
5		x1
6		x1
7		x1
8		x1
9		x1
10		x1

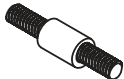
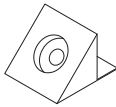
Item	Reference Image	Qty
11		x2
12		x1
13		x1
14		x1
15		x2
16		x1
17		x1
18		x2
19		x1

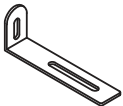
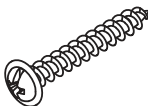
HARDWARE LIST

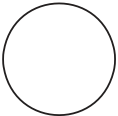
<p>A</p>  <p>x30</p>	<p>B</p>  <p>x30</p>	<p>C</p>  <p>x32</p>	<p>D</p>  <p>x4</p>
<p>E</p>  <p>φ4.2x50MM x4</p>	<p>F</p>  <p>x12</p>	<p>G</p>  <p>φ4x14mm x24</p>	<p>H</p>  <p>φ3.5x12mm x4</p>
<p>I</p>  <p>φ3x16mm x6</p>	<p>J</p>  <p>x2</p>	<p>K</p>  <p>x6</p>	<p>L</p>  <p>x2</p>
<p>M</p>  <p>x2</p>	<p>N</p>  <p>x2</p>	<p>O</p>  <p>x2</p>	<p>P</p>  <p>x2</p>
<p>Q</p>  <p>x24</p>			

1

7

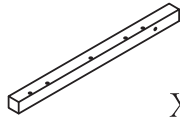

x1

8

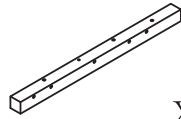

x1

9

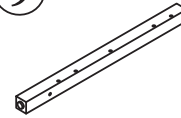

x1

10

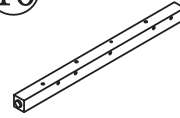

x1

B

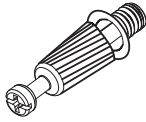

x12

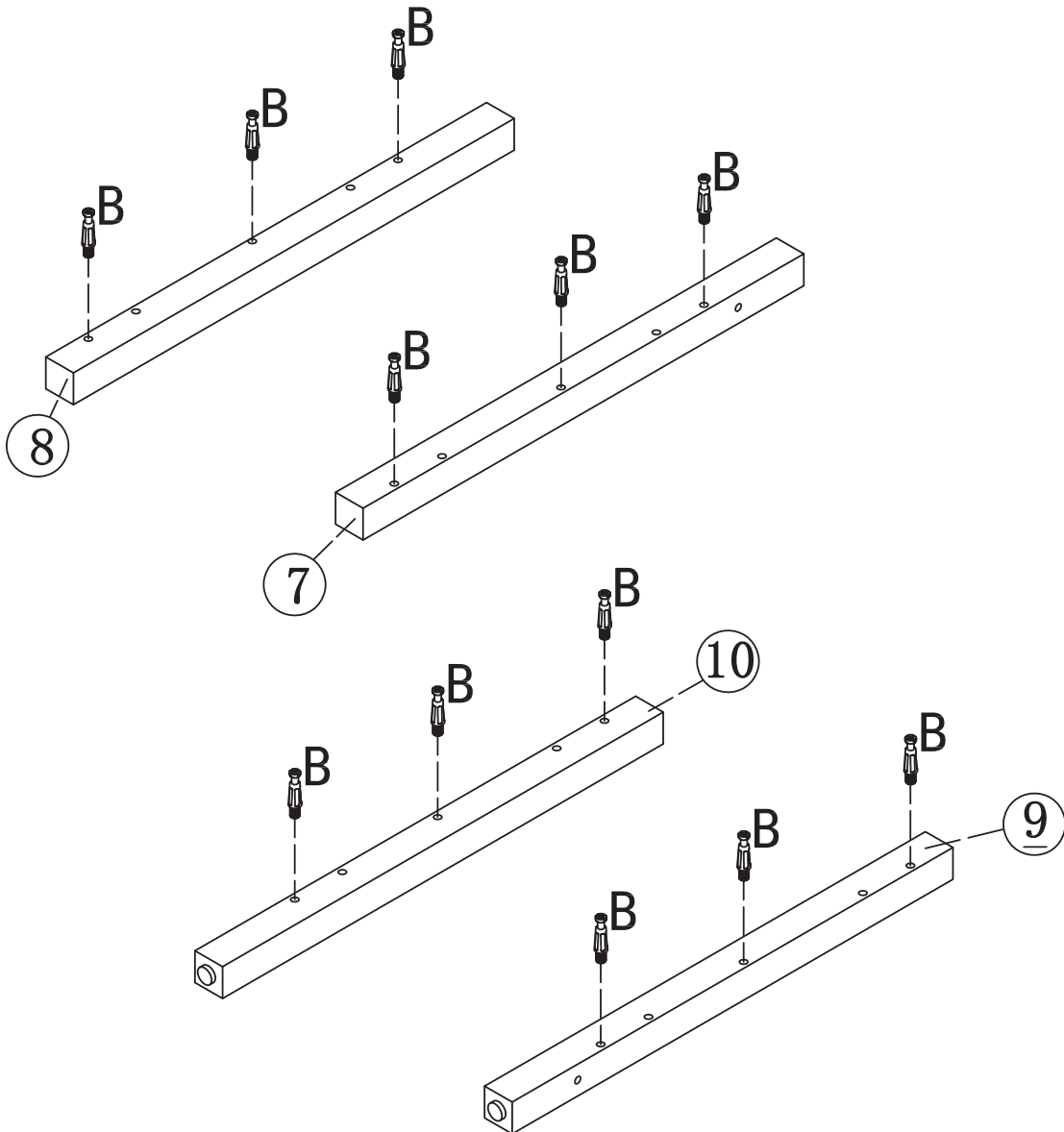

2

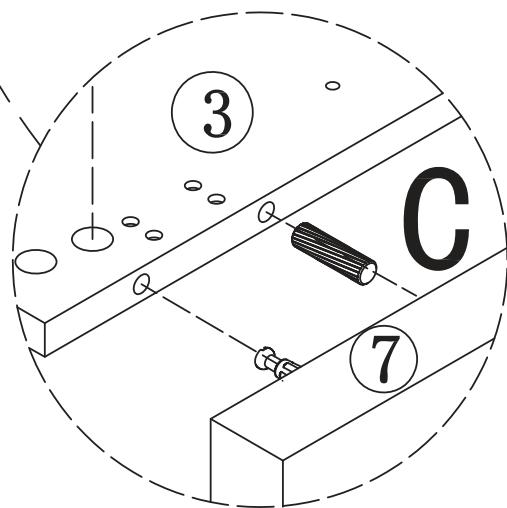
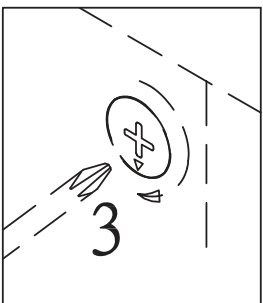
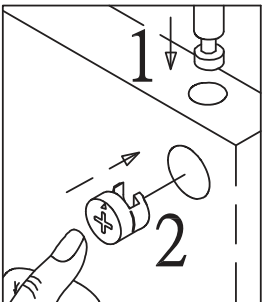
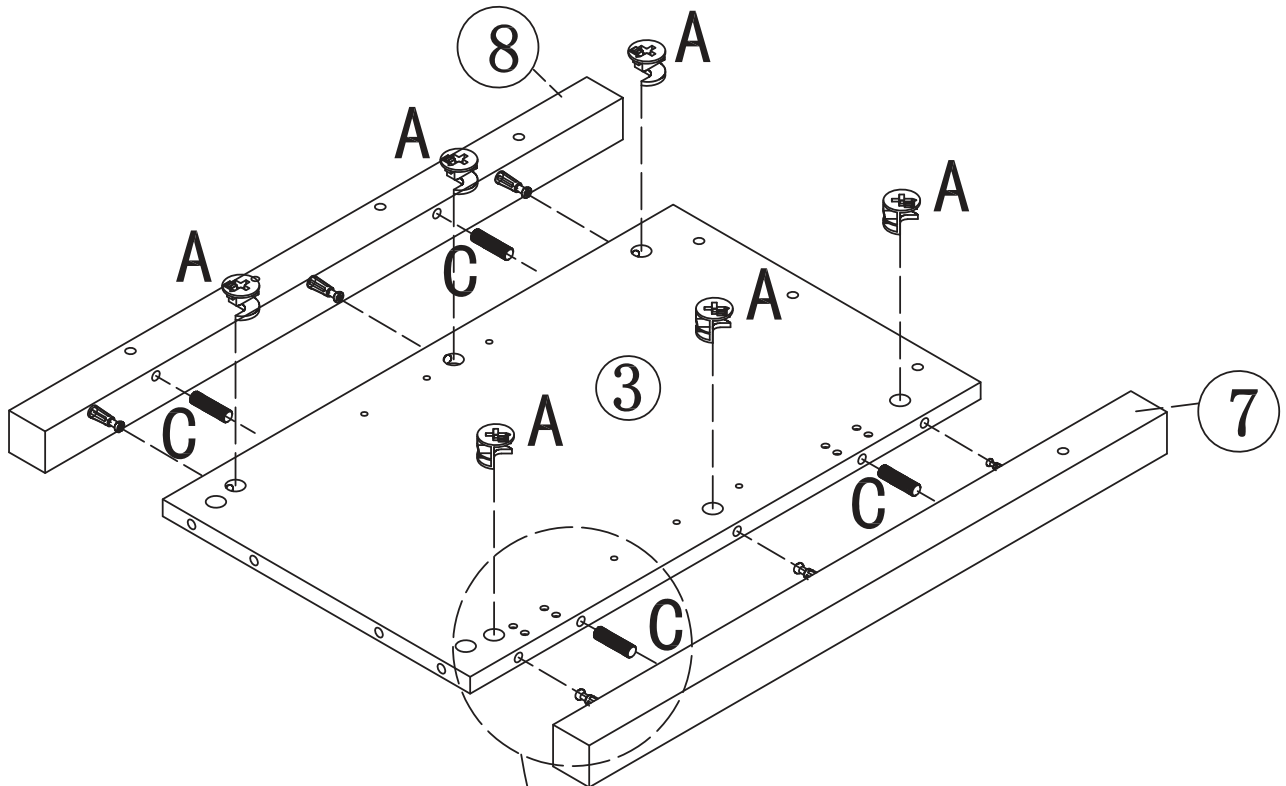
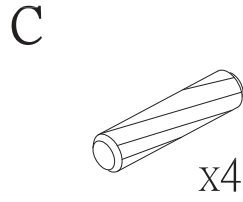
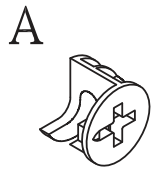
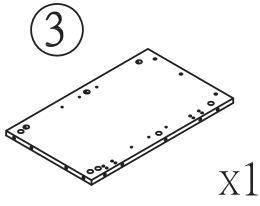

3

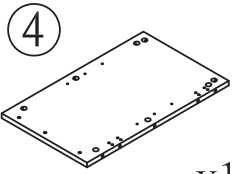

x1

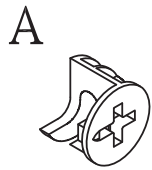

x6

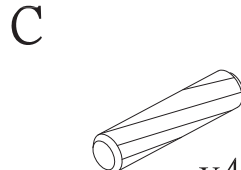

x4

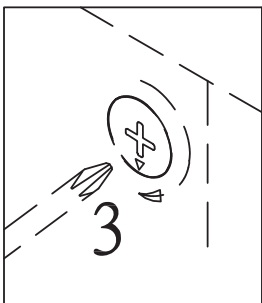
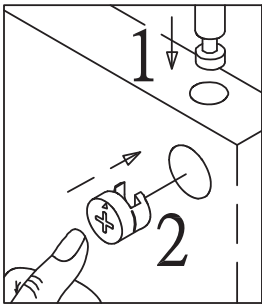
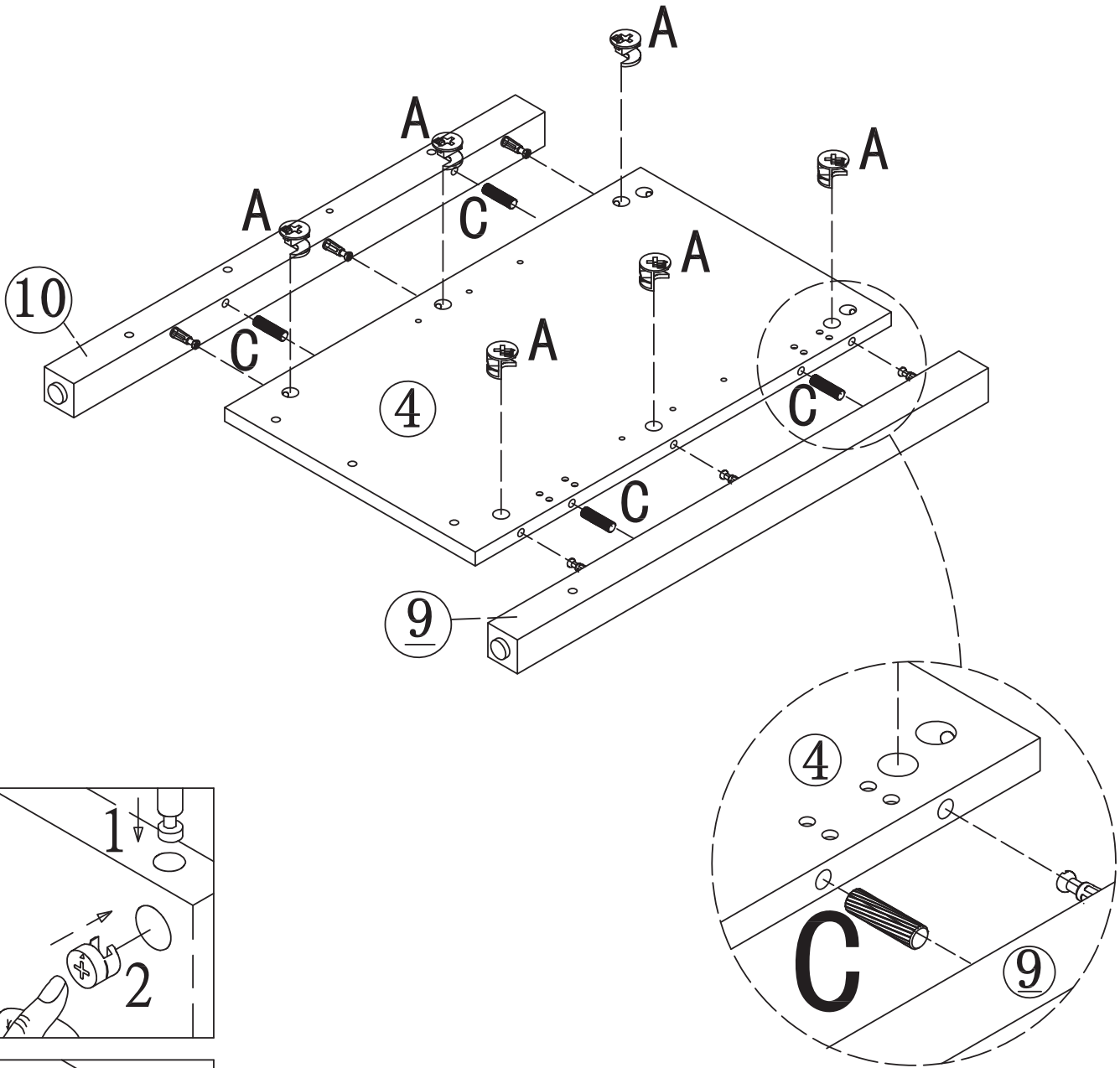

4

B

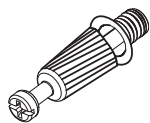

x4

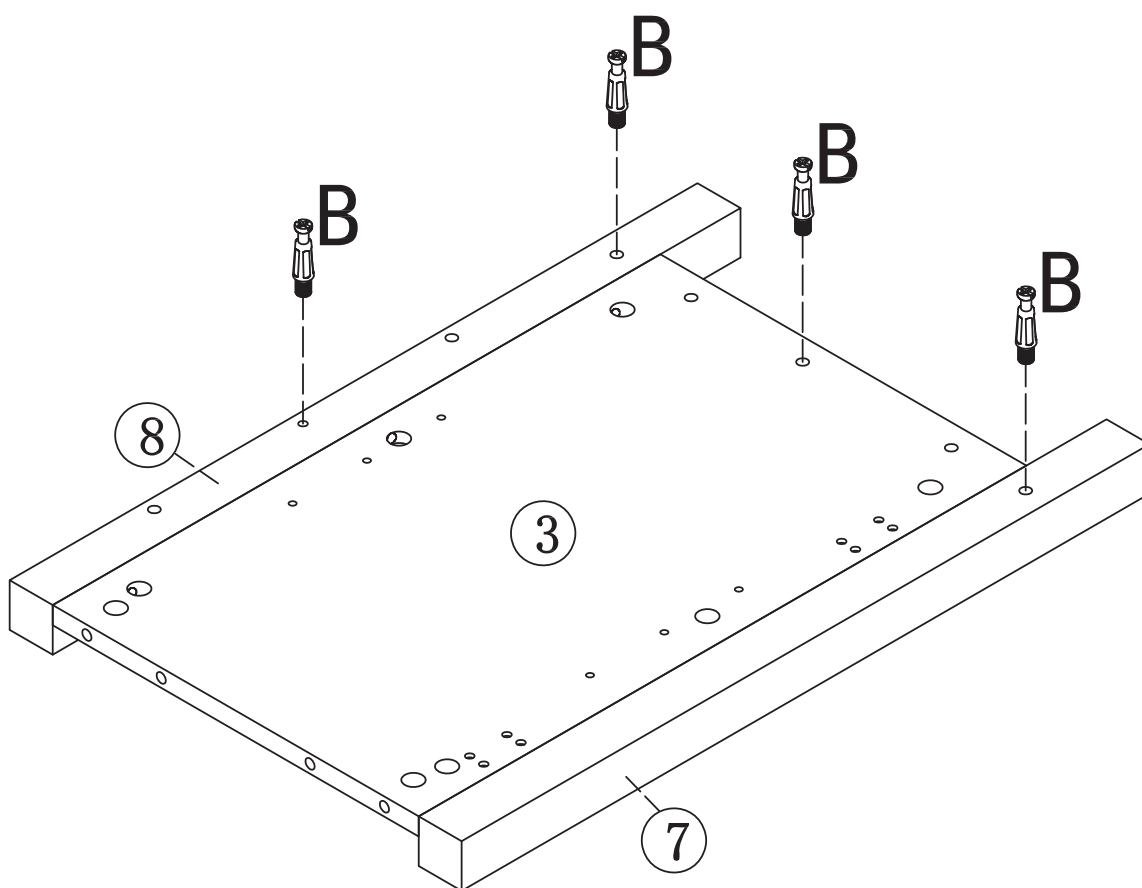

5

B



x4

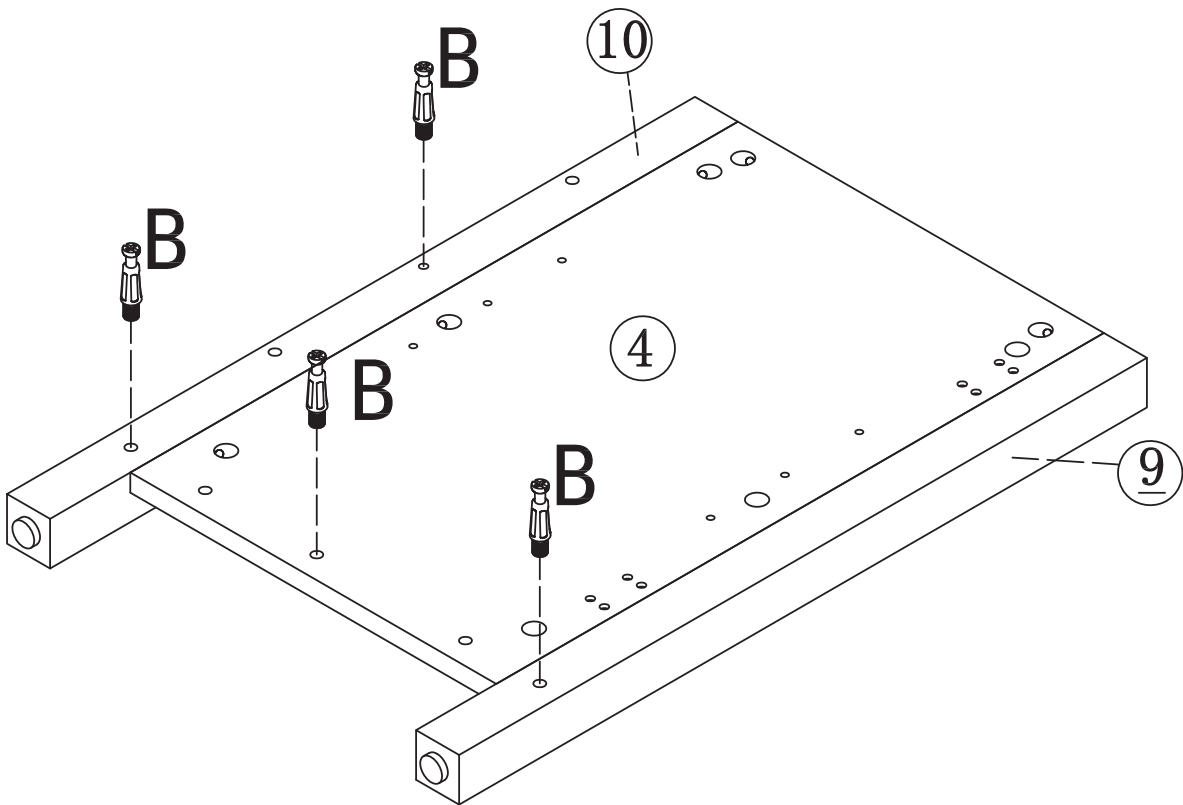

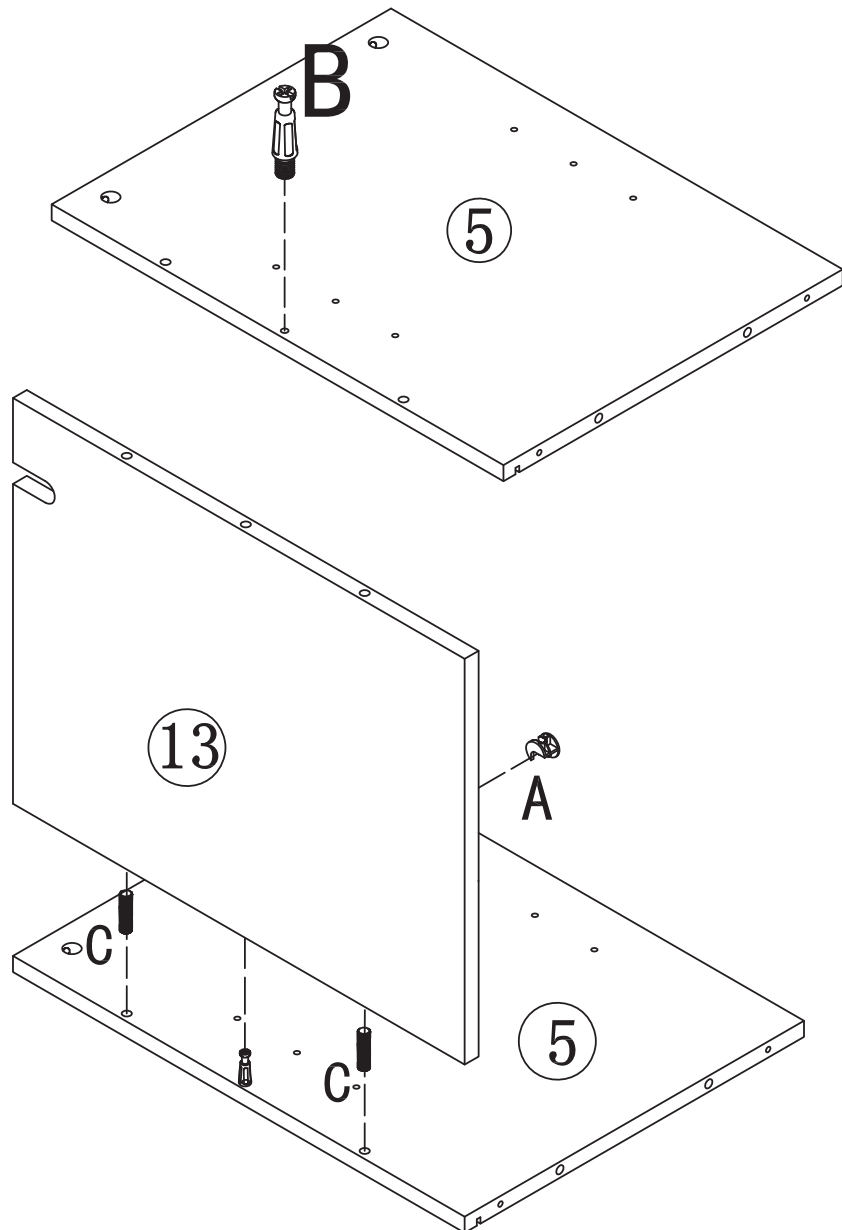
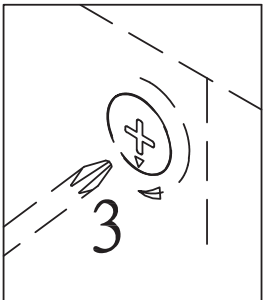
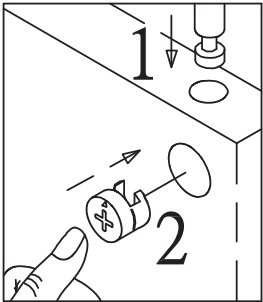
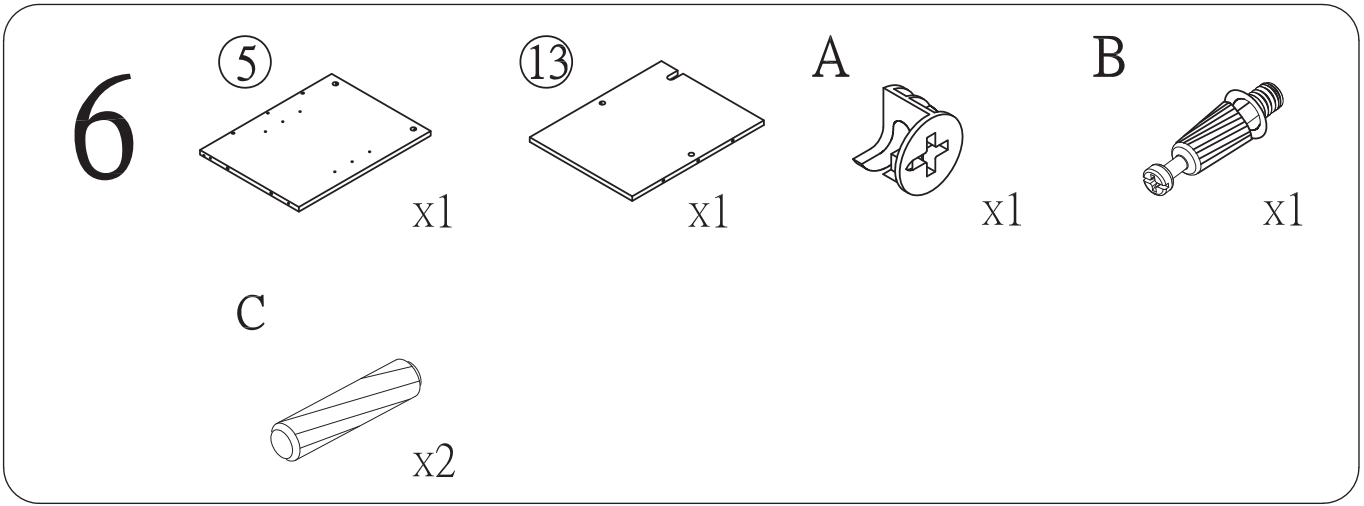

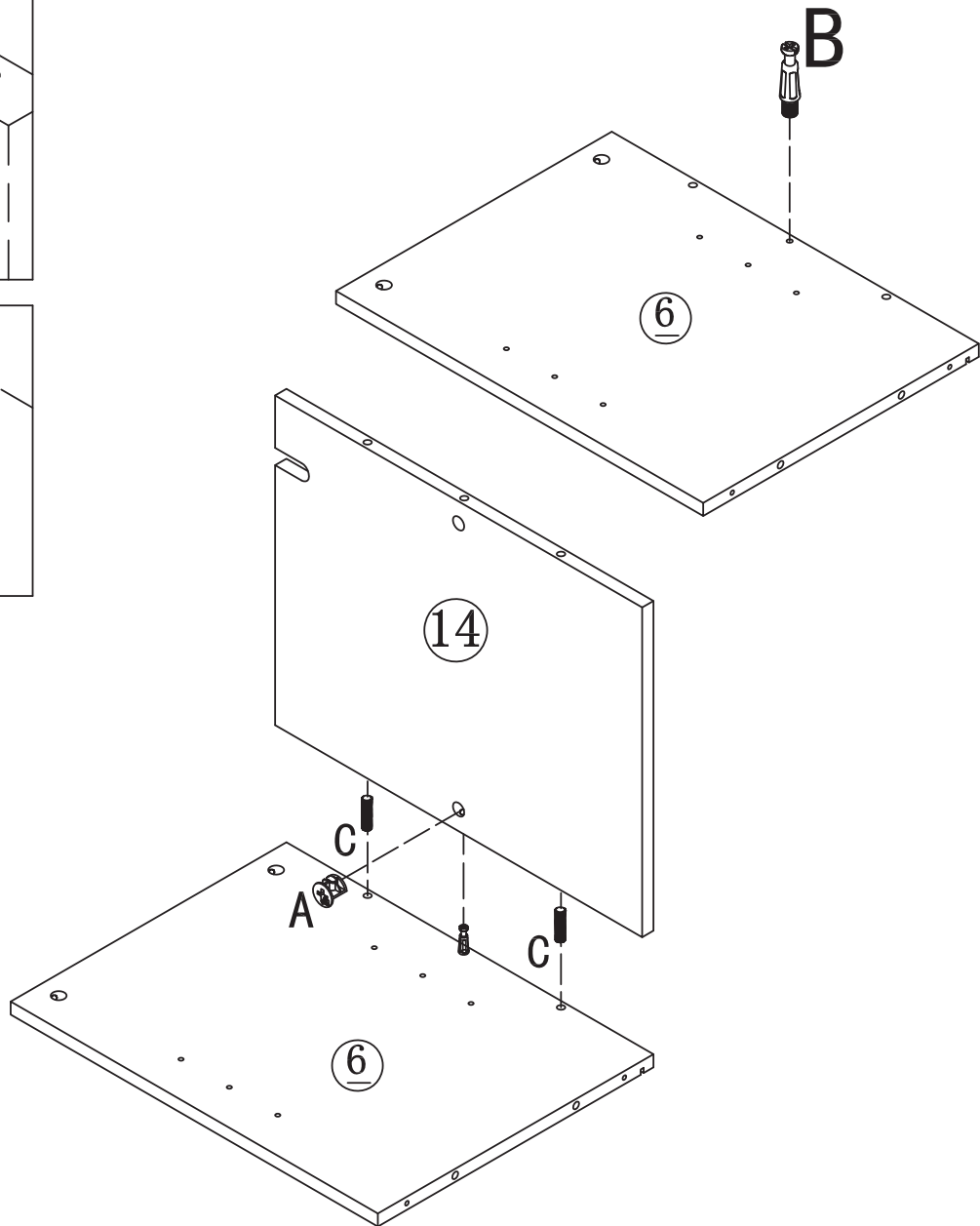
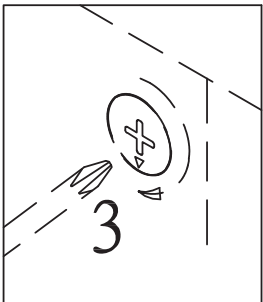
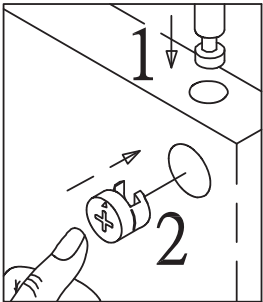
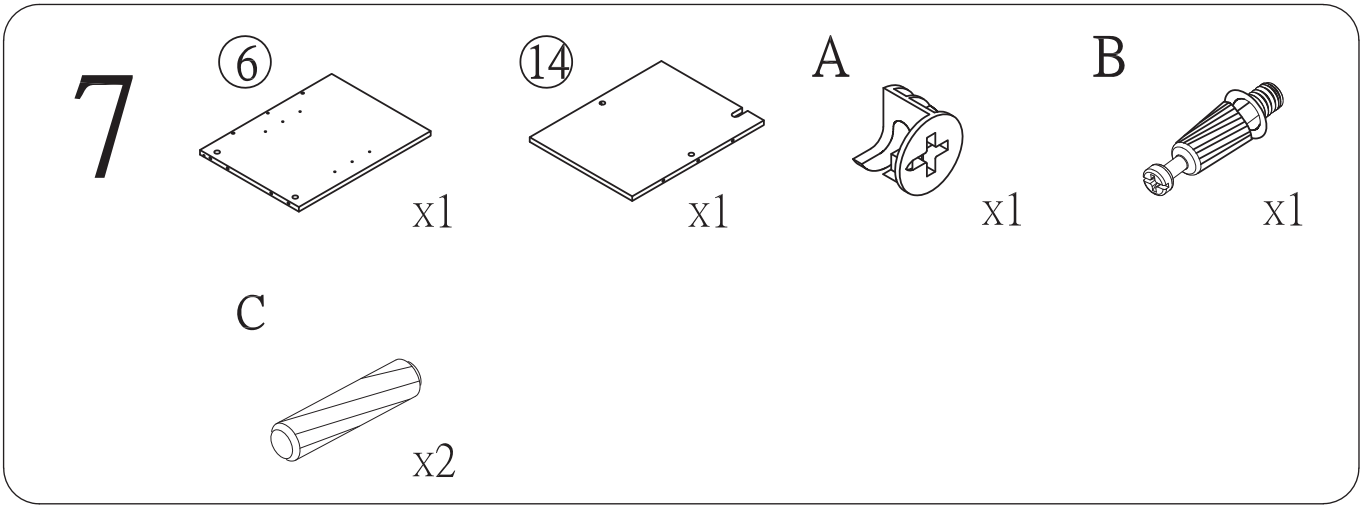

8

2

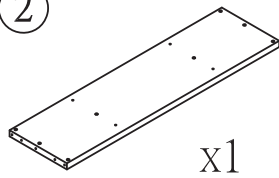

x1

C

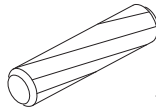

x4

E



x4

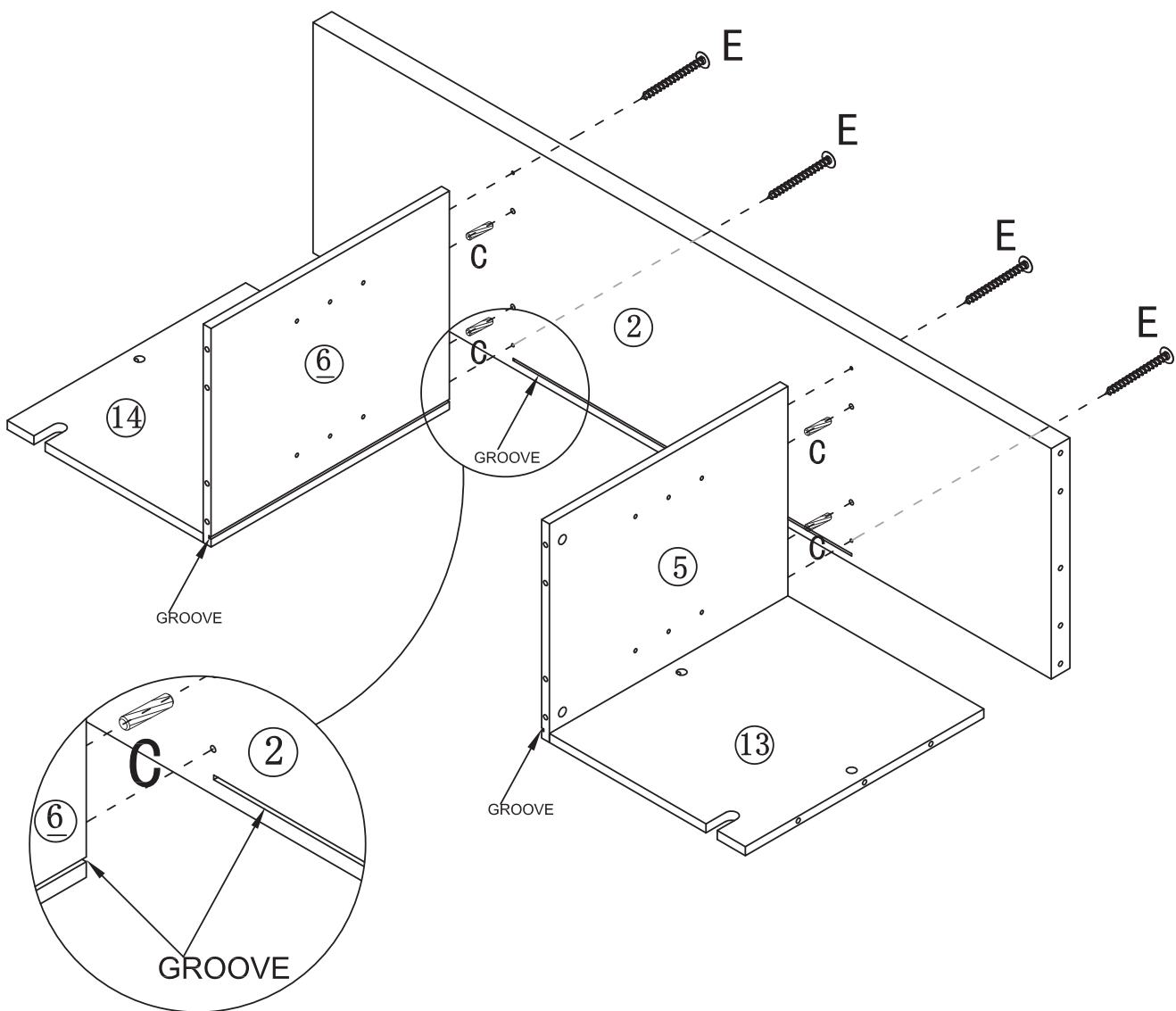

Note: Plate (6) slot
butt plate (2) slot

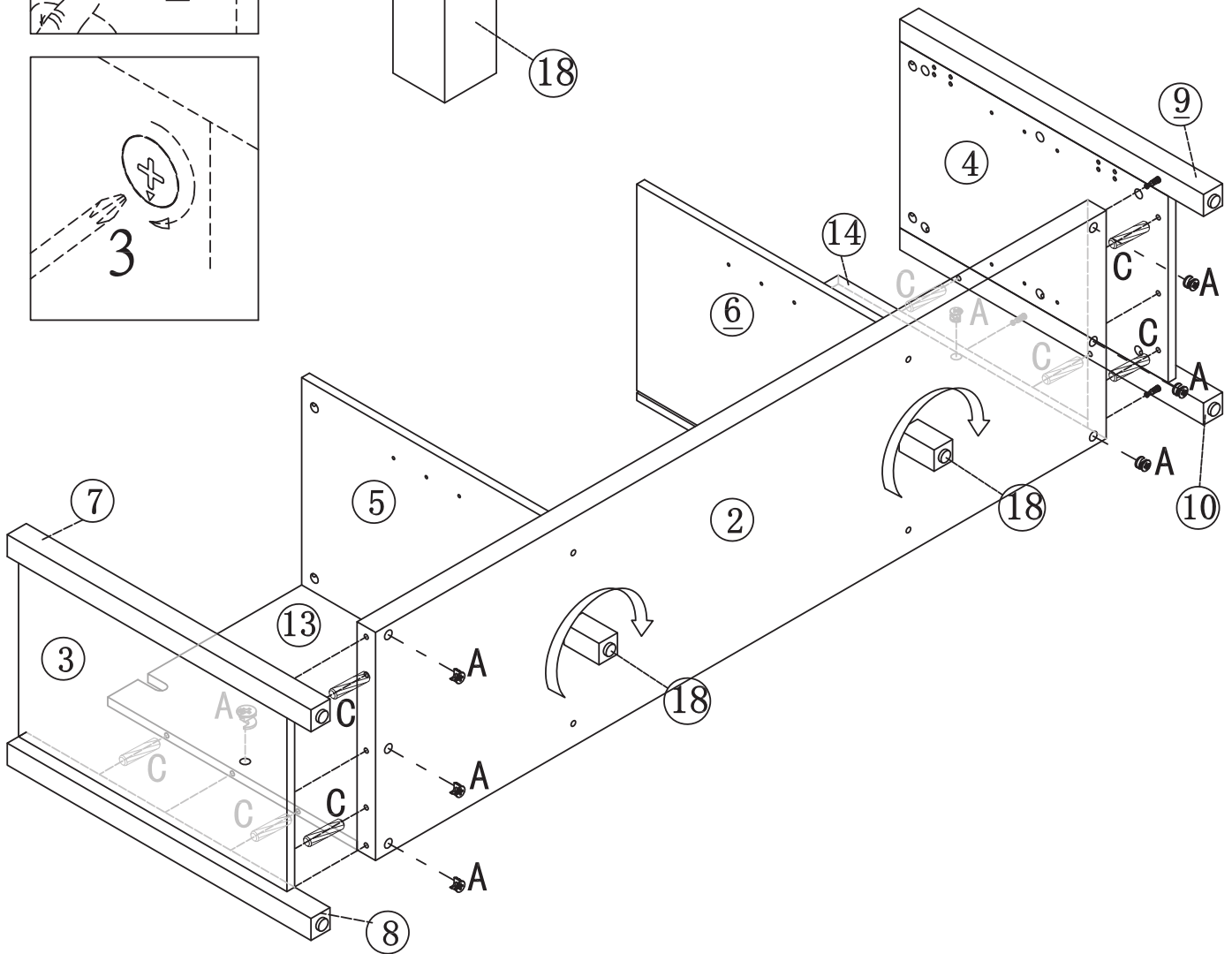
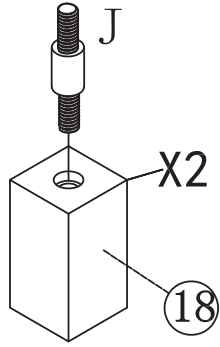
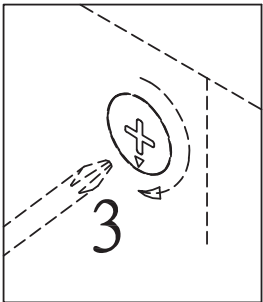
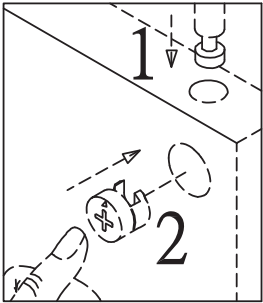
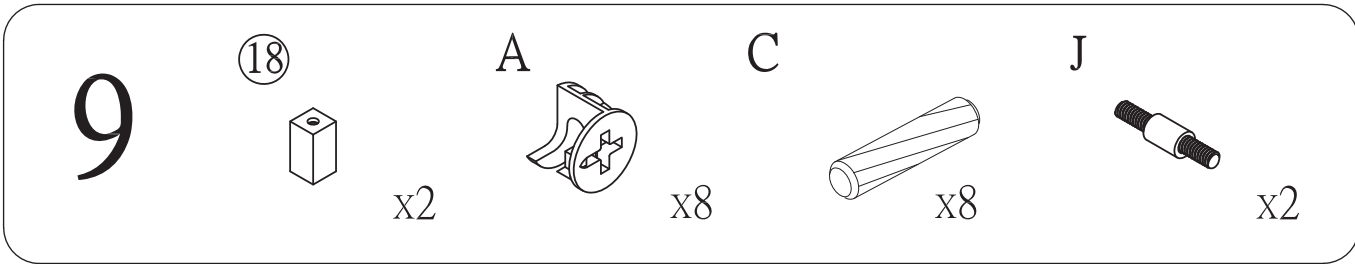

10

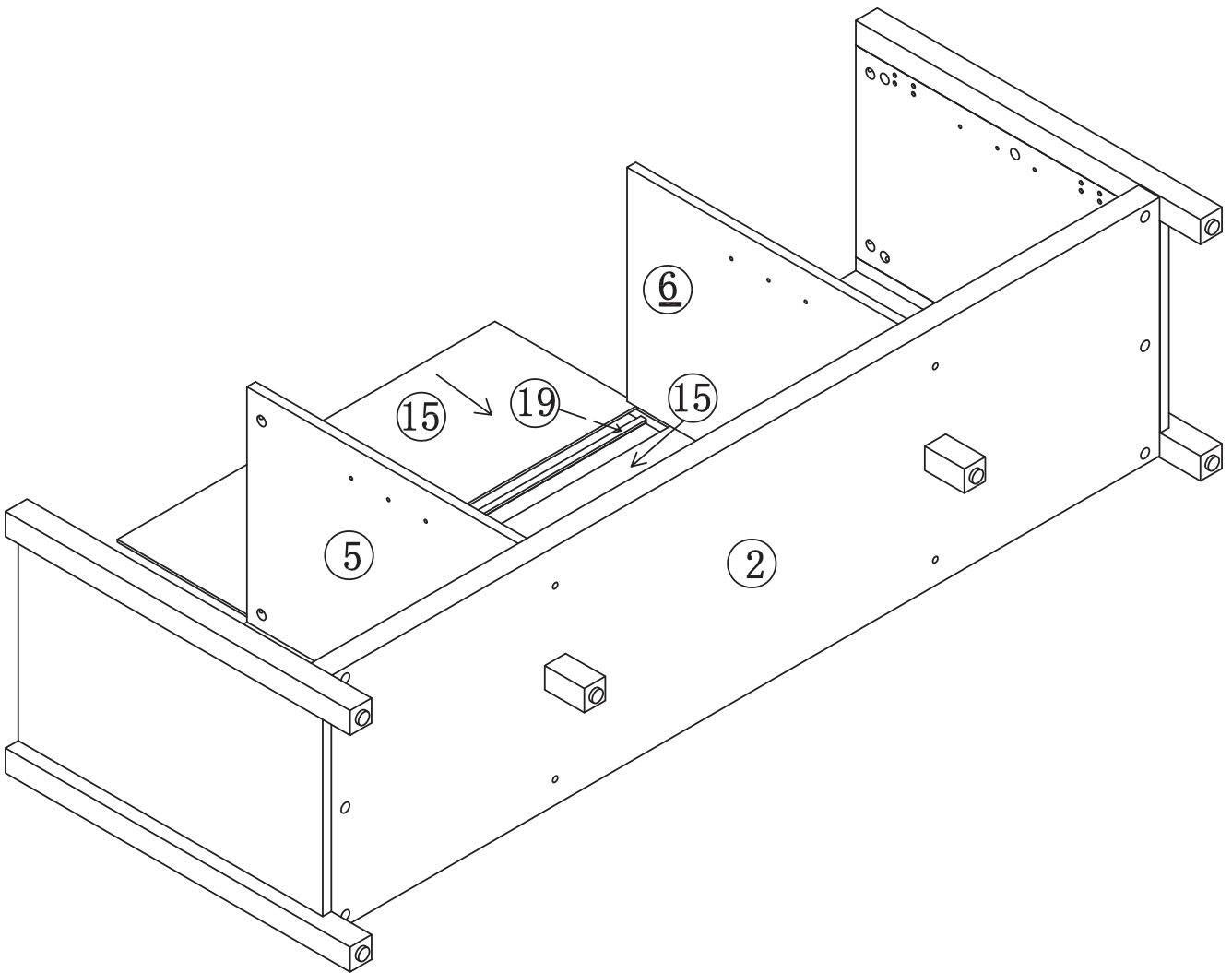
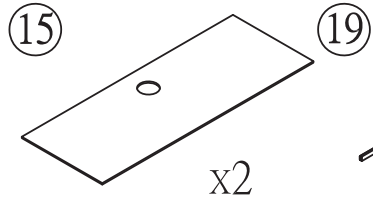

12

A

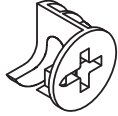

x8

C

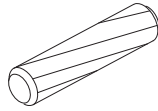

x8

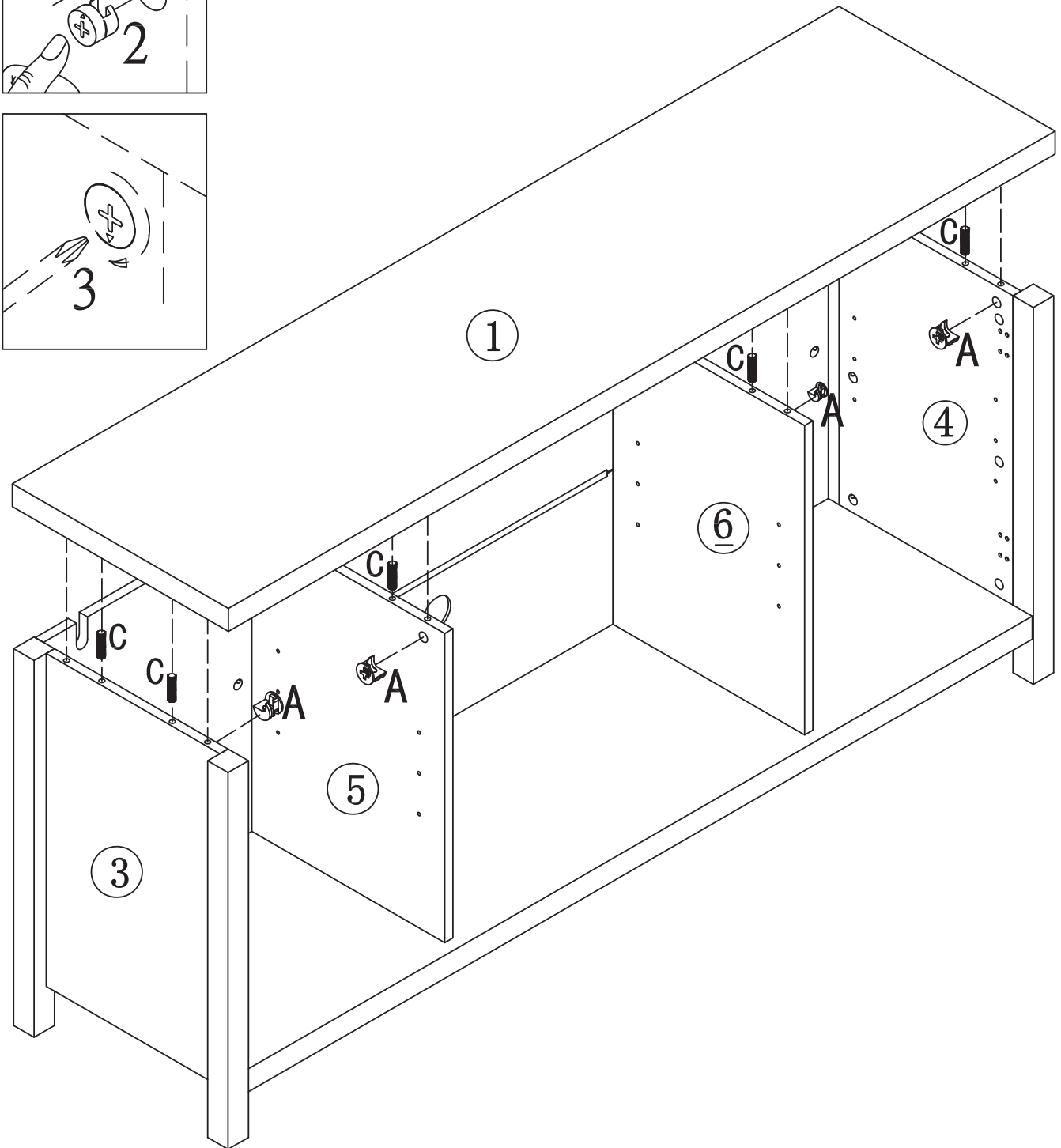
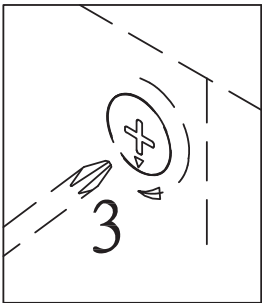
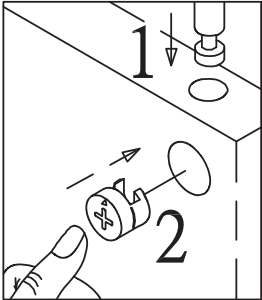

13

①①

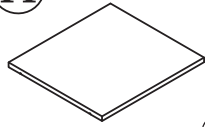

x2

①②

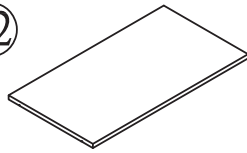

x1

F



x12

Q

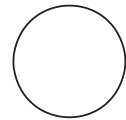

x24

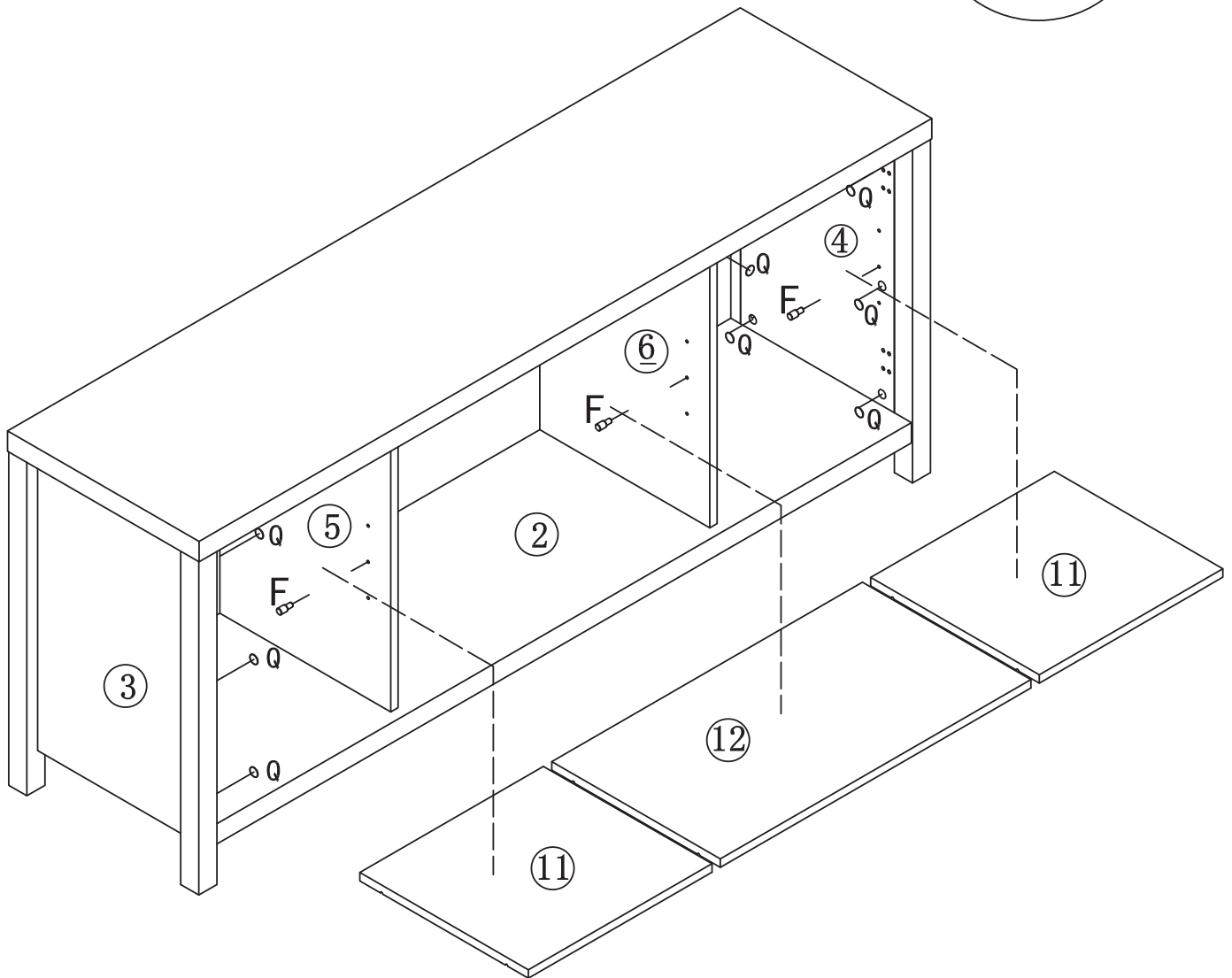
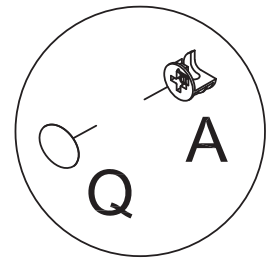

14

I



x6

K

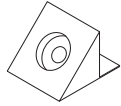

x6

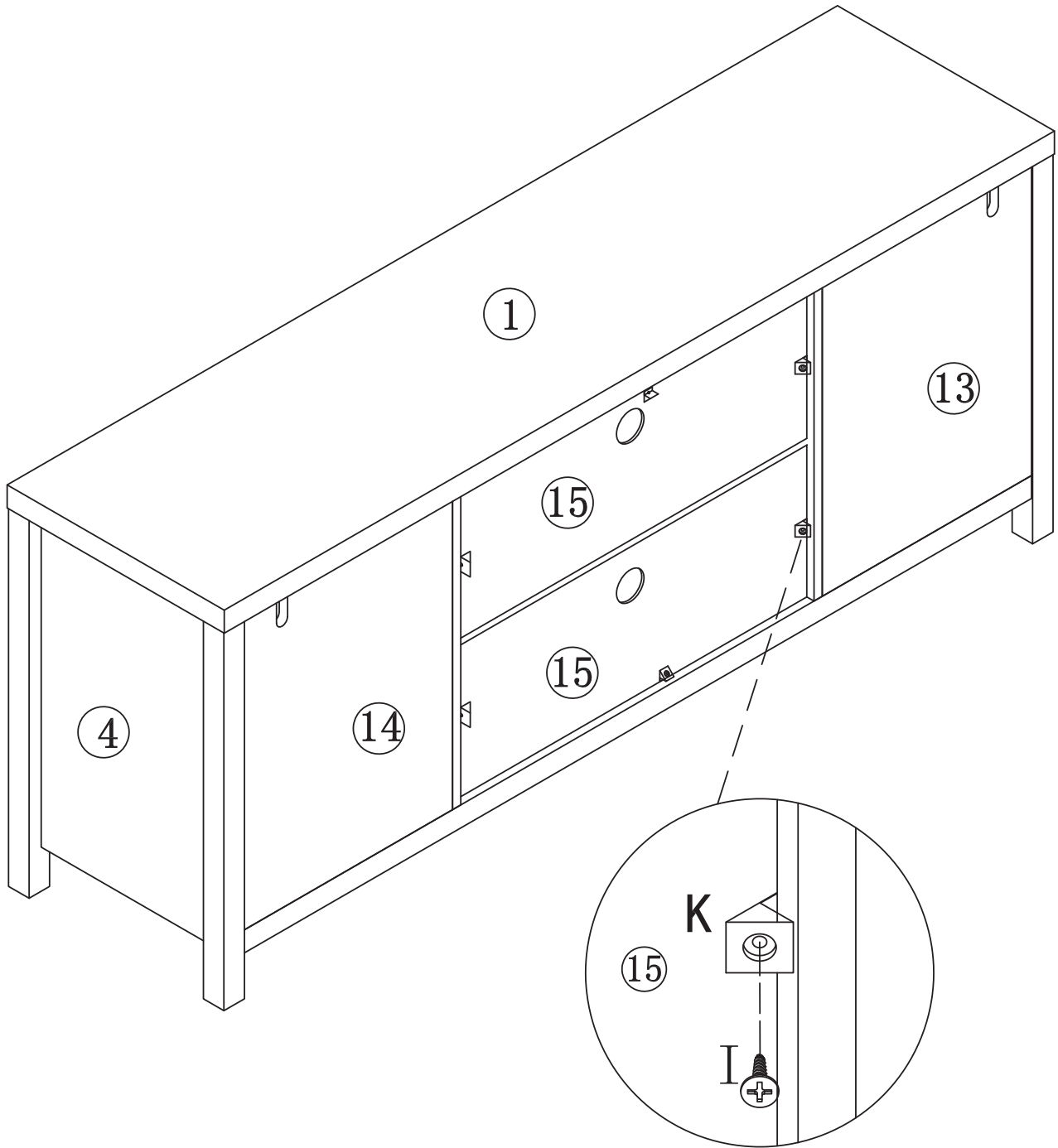

15

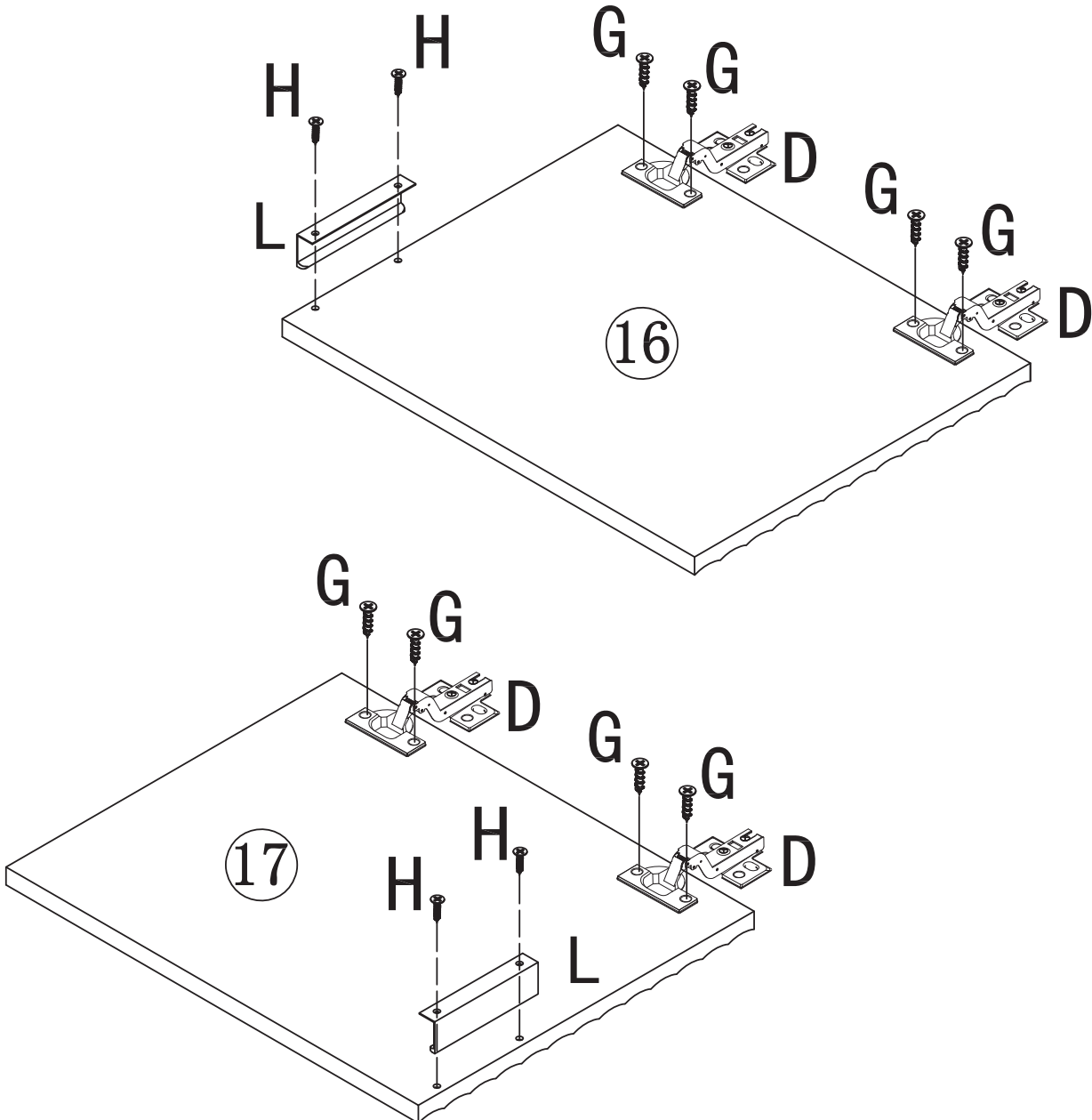
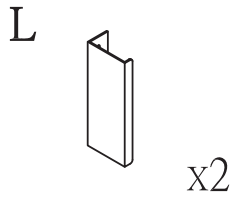
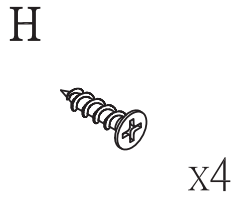
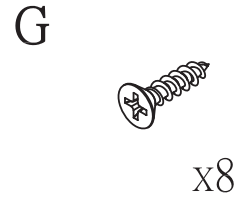
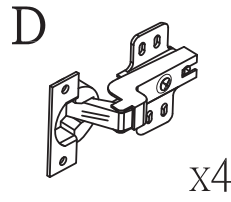
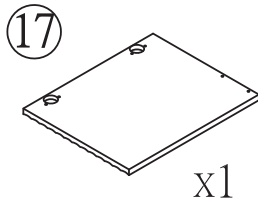
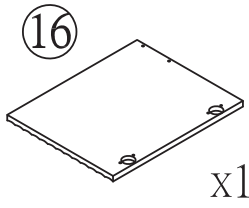

16^G



x16

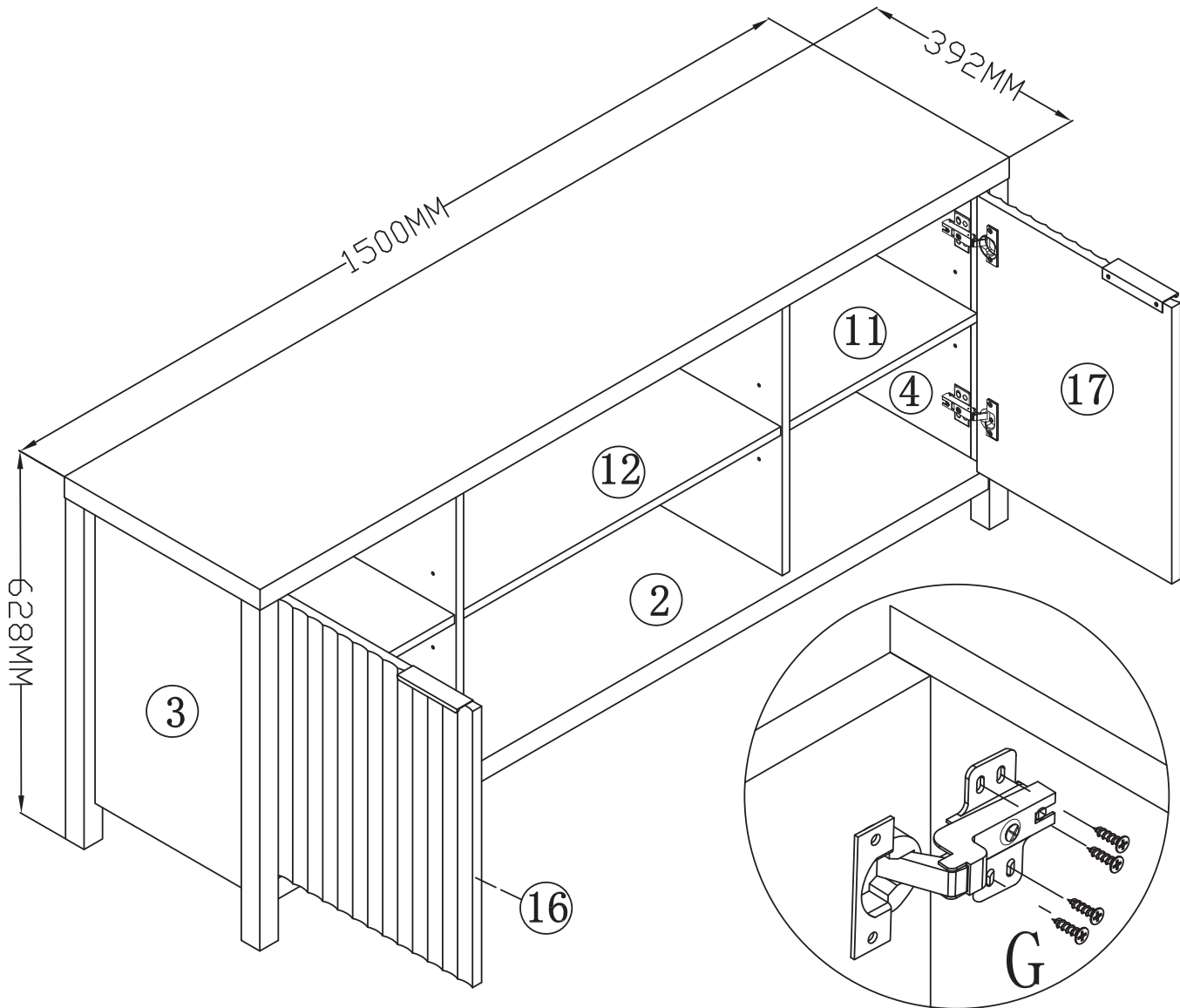

Adjusting the door

- .Before adjusting the hinge, please check whether the cabinet is skewed.
- . If the skew can not be repaired, please remove the anti-tipping device first, then adjust the cabinet to vertical position.
- .Please adjust the hinge with the door open.
- . Please operate it with more than 2 people, one person holds the door and the other one adjusts the screw.
- .Have trouble adjusting the door? Please check out our video on adjusting the door via our website or contact

17

M

O

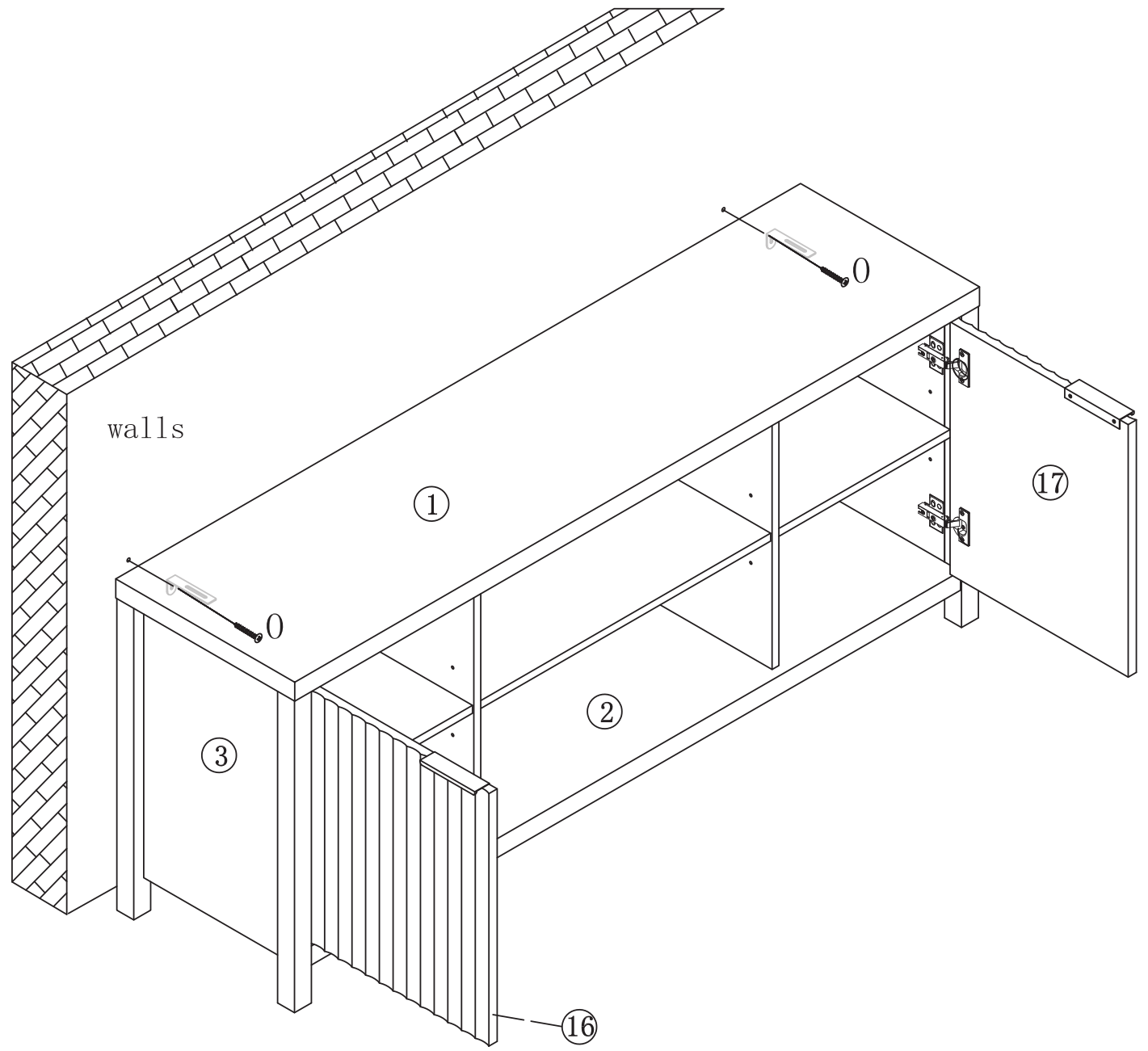
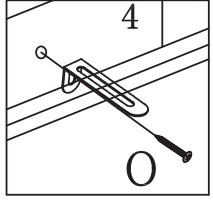
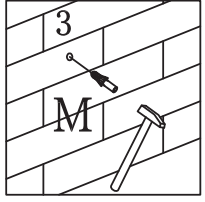
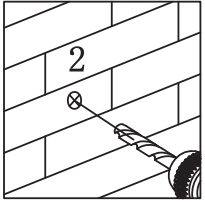
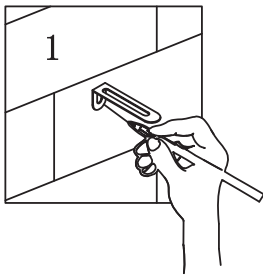
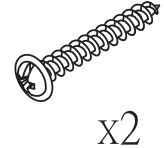
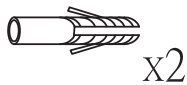

Components Name

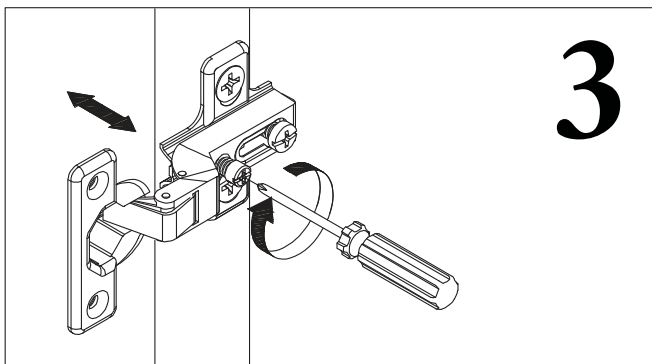
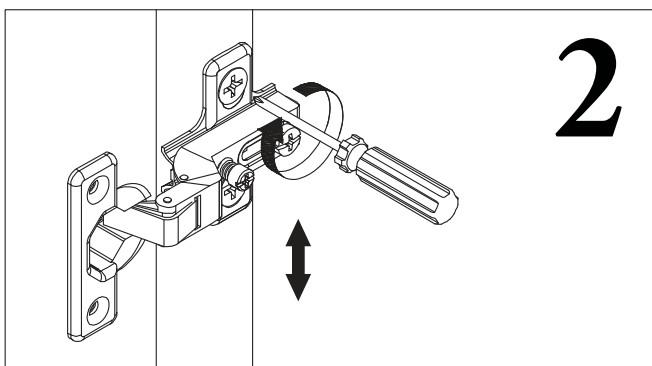
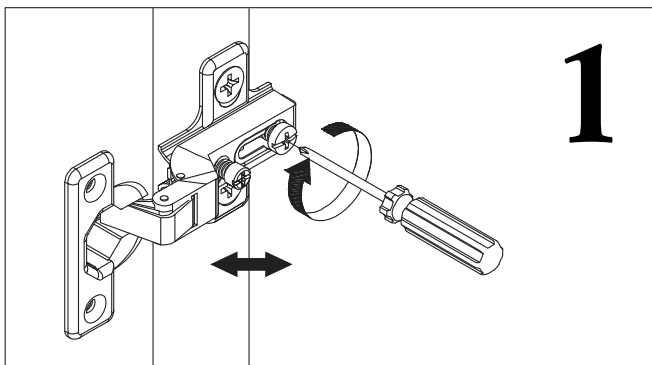
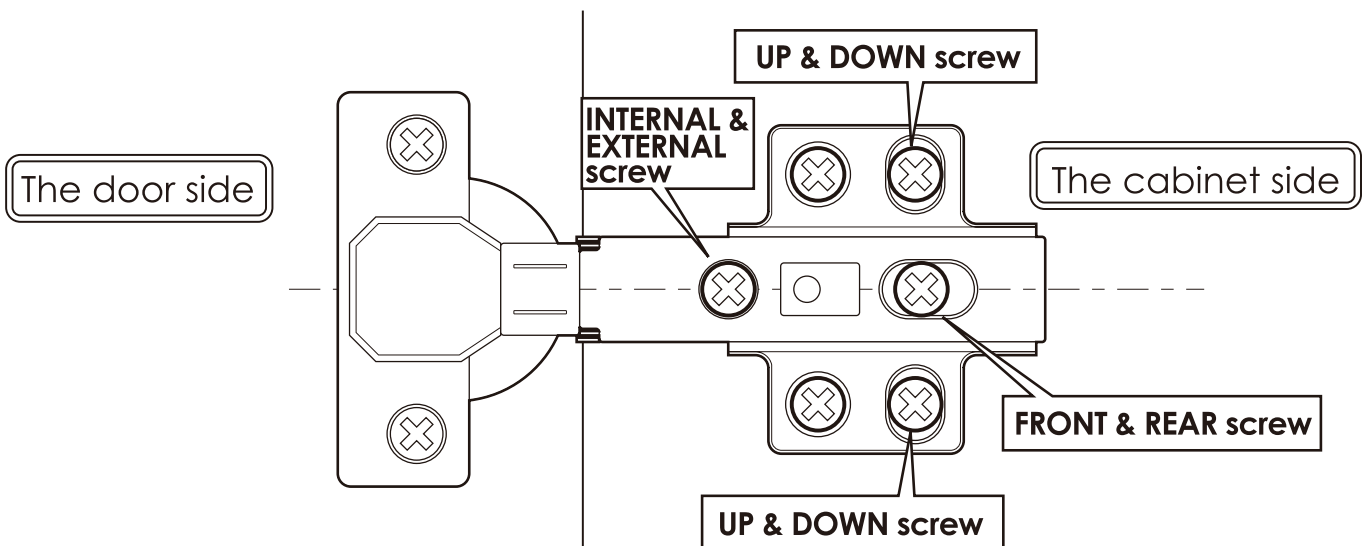

Doors may need to be adjusted after the initial shipping of the cabinet . The cabinet doors have a three-way adjustment fea-ture. Height, side to side, level and depth can be adjusted. With the hinge slightly closed you can access the middle screw for up / down adjustment . With the hinge fully extended you can access the front and back screws. These screws will move the door side to side and in and out.

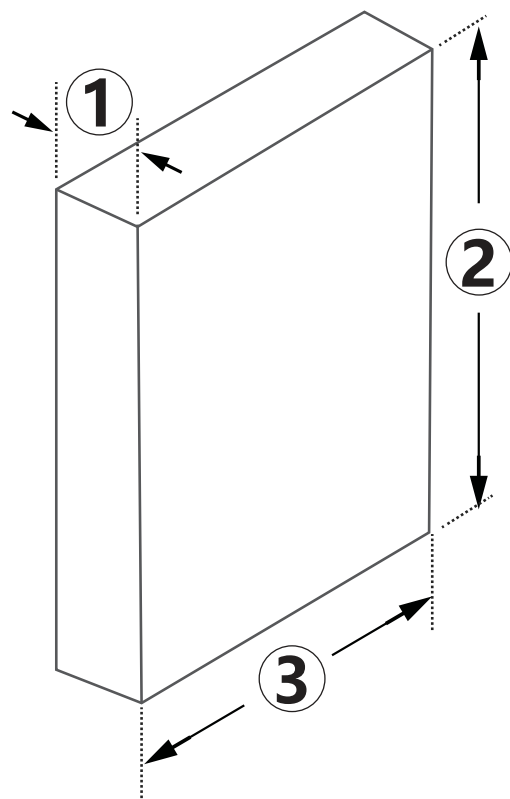

Warranty Information

Thank you for purchasing our furniture. We are committed to delivering high-quality furniture that meets your expectations. This product comes with a 1-year limited warranty covering defects in materials and workmanship under normal use from the date of purchase.

Warranty Coverage

Structural damage or defects in the wood panels.

Malfunction of hardware components such as hinges or screws.

Any damage caused during transit that affects product functionality.

Exclusions

Damage caused by improper assembly or modifications.

Issues caused by external factors such as moisture or extreme temperatures.

In case of any warranty claims, please contact our customer service team with your proof of purchase and a detailed description of the issue.

Quality Assurance (QA) & Common After-Sales Issues

We take pride in our rigorous quality assurance process to ensure every piece of furniture meets high standards. However, we understand that issues may arise. Below are some of the common after-sales concerns and their potential solutions:

Gaps Between Panels

If there are visible gaps between the panels, please check the assembly process to ensure all parts are securely fastened. If the issue persists, contact our customer service for assistance.

Misaligned Doors

In case the doors are not aligned properly, adjustments to the hinges may be needed. Instructions for adjusting the hinges are included in the manual. If adjustments do not resolve the issue, please contact us.

Shipping Damage

If your furniture arrives with any damage from shipping, such as dents or scratches, please report the damage immediately. We will arrange for a replacement or repair.

Incorrect Hole Alignment

If any holes for assembly are misaligned, please refrain from forcing the components together. Contact our customer service for troubleshooting or part replacement.

Thank You!

For Purchasing from us

Despite our reinforced packaging, transit mishandling can sometimes occur. In the rare event that your product arrives damaged, we're here to assist you. If your product is in perfect condition, you can disregard this message.

If you discover any damage upon receipt of your package, please contact our after-sales mailbox immediately

Additionally, we kindly request your assistance in filing a claim against the shipping carrier for the mishandling of your package. Please help us by providing clear photos as follows:

- ★ **Complete Shipping Label (Express Delivery Waybill):** Take a clear image of the entire shipping label affixed to the package with visible and legible text and barcodes
- ★ **Exterior Packaging Damage:** Capture a comprehensive photo showing the damaged exterior of the shipping package.
- ★ **Interior Item Damage:** Provide images focusing on the damaged areas of product

Your cooperation is invaluable, and we assure you that we're committed to resolving this issue promptly. Your satisfaction remains our top priority.

Thank you for your understanding and assistance.
Best regards,