

# ASSEMBLY INSTRUCTIONS

## 3 DRAWER DRESSER



# Thank you for your purchase!

Remove all parts and hardware from the box and lay on a carpeted or scratch-free work surface.  
Do not dispose of any contents until assembly is completed.

## TOOLS REQUIRED:

ALLEN KEY (included)



SCREW DRIVER (Not Included)

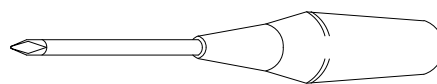

## PARTS ENCLOSED IN CARTON

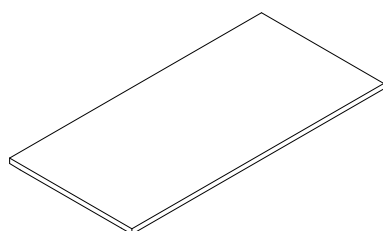

1. Top panel (1 pc)

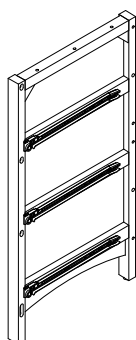

2. Left side (1 pc)

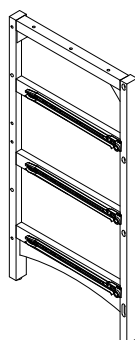

3. Right side (1 pc)

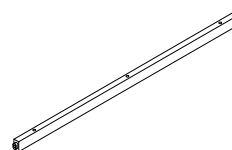

4. Top front rail (1 pc)

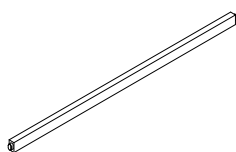

5. Drawer rail (2 pcs)

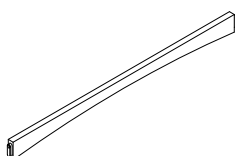

6. Bottom rail (1 pc)

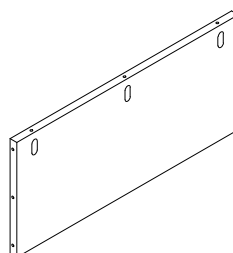

7. Top back panel (1 pc)

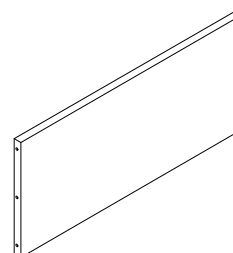

8. Bottom back panel (1 pc)

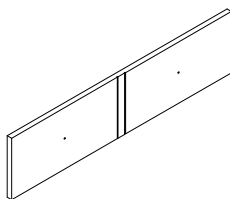

9. Top drawer front (1 pc)

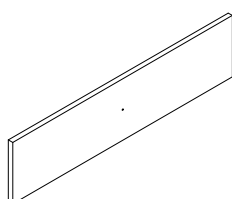

10. Bottom drawer front (2 pcs)

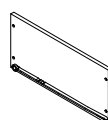

11. Drawer left side (3 pcs)

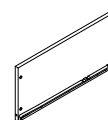

12. Drawer right side (3 pcs)

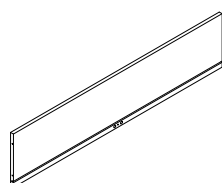

13. Drawer back (3 pcs)

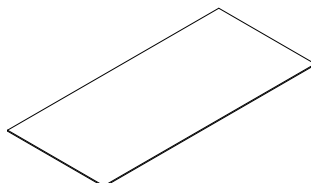

14. Drawer bottom panel (3 pcs)

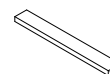

15. Drawer support (3 pcs)

Do not fully tighten all Screws until all parts are in place.

## TOOLS REQUIRED:

ALLEN KEY (included)



SCREW DRIVER (Not Included)

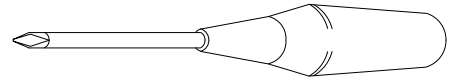

### HARDWARE

(A) Allenbolt 2-3/4" (70mm) (12 pcs)

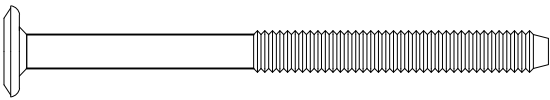

(B) Allenbolt 1-1/2" (38 mm) (10 pcs)

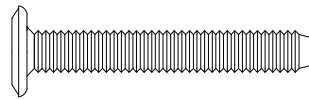

(C) Barrel nut (12 pcs)

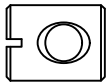

(D) Spring washer (19 pcs)



(E) Crescent washer (3 pcs)



(F) Dowel Ø8x30mm (6 pcs)

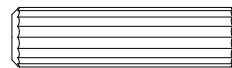

(G) Dowel Ø6x30mm (12 pcs)

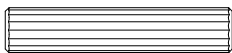

(H) Screw 1" (25 mm) (30 pcs)

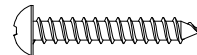

(J) Bolt 1" (25 mm) (4 pcs)



(K) Knob (4 pcs)

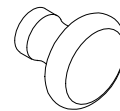

(L) Allen key (1 pc) (length may vary)



Do not fully tighten all bolts until all parts are in place.  
(please add an extra 1/2 revolution to the bolts when using spring washer after tightening)

## STEP 1 " ASSEMBLY OF DRESSER"

### THIS STEP REQUIRES :

- 2. Left side (1 pc)
- 4. Top front rail (1 pc)
- 5. Drawer rail (2 pcs)
- 6. Bottom rail (1 pc)
- 7. Top back panel (1 pc)
- 8. Bottom back panel (1 pc)

(L) Allen key (1 pc)



(A) Allenbolt 2-3/4" (70mm) (6 pcs)

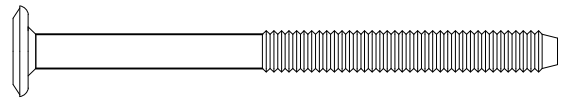

(C) Barrel nut (6 pcs)

(D) Spring washer (6 pcs)

(F) Dowel Ø8x30mm (2 pcs)

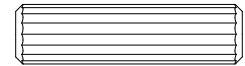
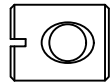

FIG 1

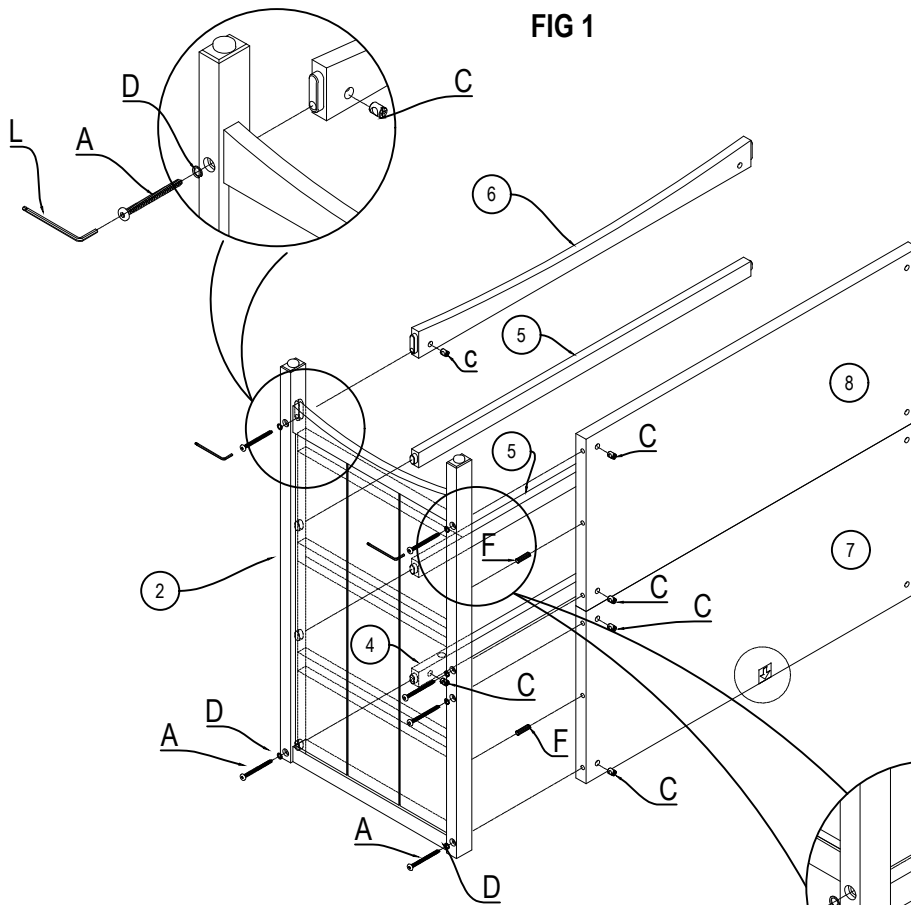
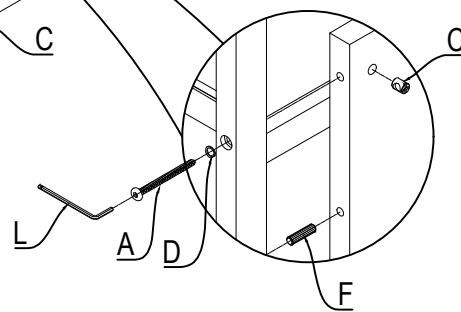

FIG 2



### STEP 1 :

- Lay Left side (2) and Top back panel (7) upside down.
- Insert Dowel (F) into middle hole on top back panel (7), bottom back panel (8).
- Attach Top back panel (7) and Bottom back panel (8) to Left side (2) by using Allen bolt (A), Barrel nut (B), Spring washer (D) as shown in FIG 2. Tighten all bolts with Allen key (L).
- Insert the tenon on the end of Top front rail (4), Drawer rail (5) and Bottom rail (6) into mortise on Left side (2) as diagram. Secure top front rail (4) and bottom rail (6) by using Allen bolt (A), Barrel nut (C), Spring washer (D) as shown in FIG 1. Tighten all bolts with Allen key (L).

## STEP 2 " ASSEMBLY OF DRESSER"

THIS STEP REQUIRES :

(L) Allen key (1 pc)

(A) Allenbolt 2-3/4" (70mm) (6 pcs)

3. Right side (1 pc)

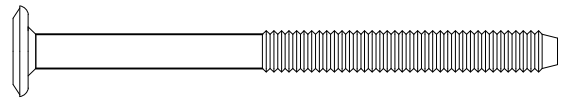

(C) Barrel nut (6 pcs)

(D) Spring washer (6 pcs)

(F) Dowel Ø8x30mm (2 pcs)

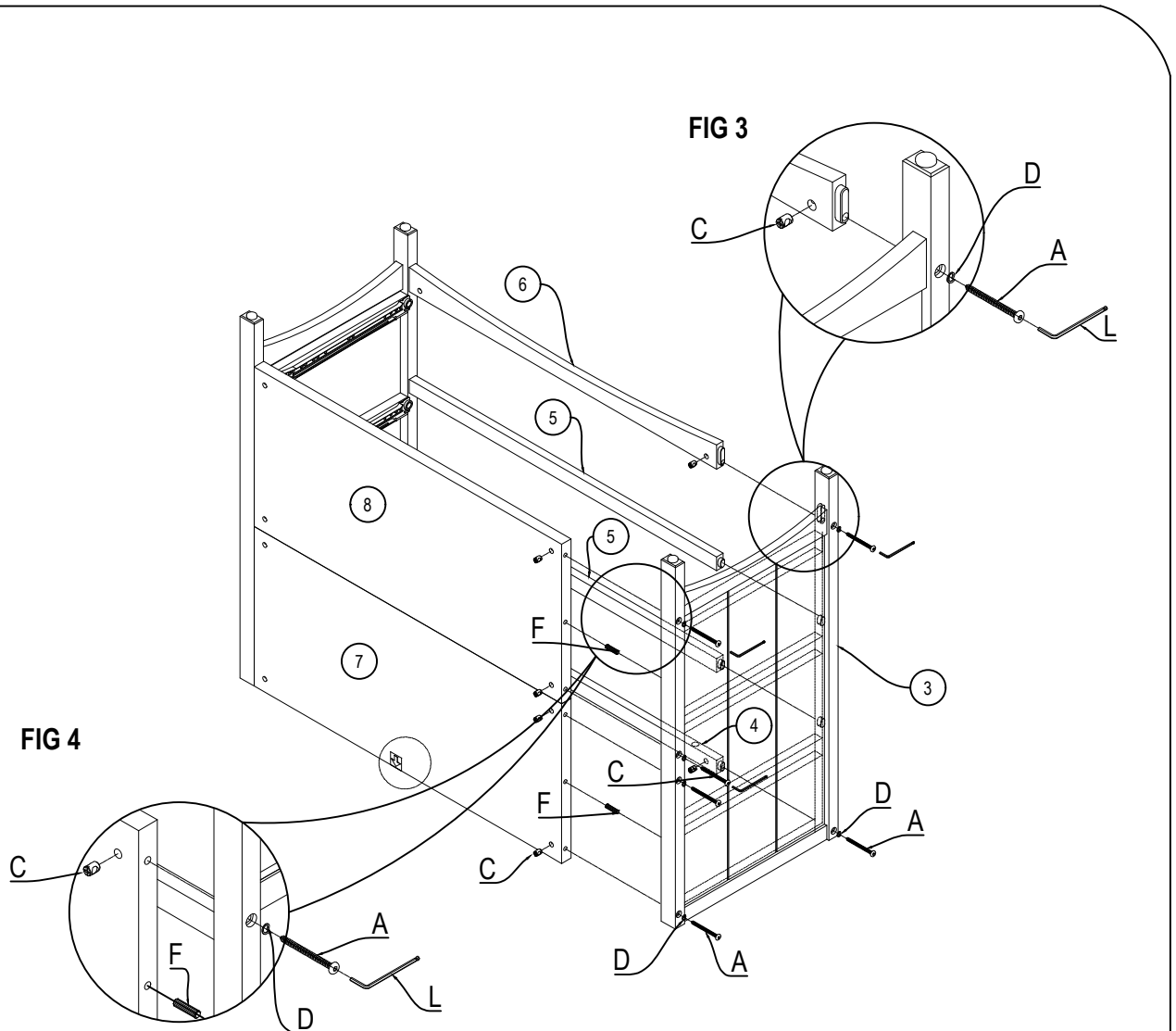
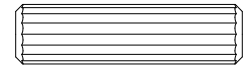
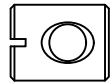

### STEP 2 :

- Lay Right side (3) upside down.
- Insert Dowel (F) into middle hole on top back panel (7), bottom back panel (8).
- Attach Top back panel (7) and Bottom back panel (8) to Right side (3) by using Allen bolt (A), Barrel nut (C), Spring washer (D) as shown in FIG 4. Tighten all bolts with Allen key (L).
- Insert the tenon on the end of Top front rail (4), Drawer rail (5) and Bottom rail (6) into mortise on Right side (3) as diagram. Secure top front rail (4) and bottom rail (6) by using Allen bolt (A), Barrel nut (C), Spring washer (D) as shown in FIG 3. Tighten all bolts with Allen key (L).

## STEP 3 " ASSEMBLY OF DRESSER"

THIS STEP REQUIRES :

(L) Allen key (1 pc)

(B) Allenbolt 1-1/2" (38 mm) (10 pcs)

1. Top panel (1 pc)

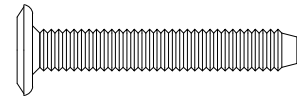

(E) Crescent washer (3 pcs)

(D) Spring washer (7 pcs)

(F) Dowel Ø8x30mm (2 pcs)

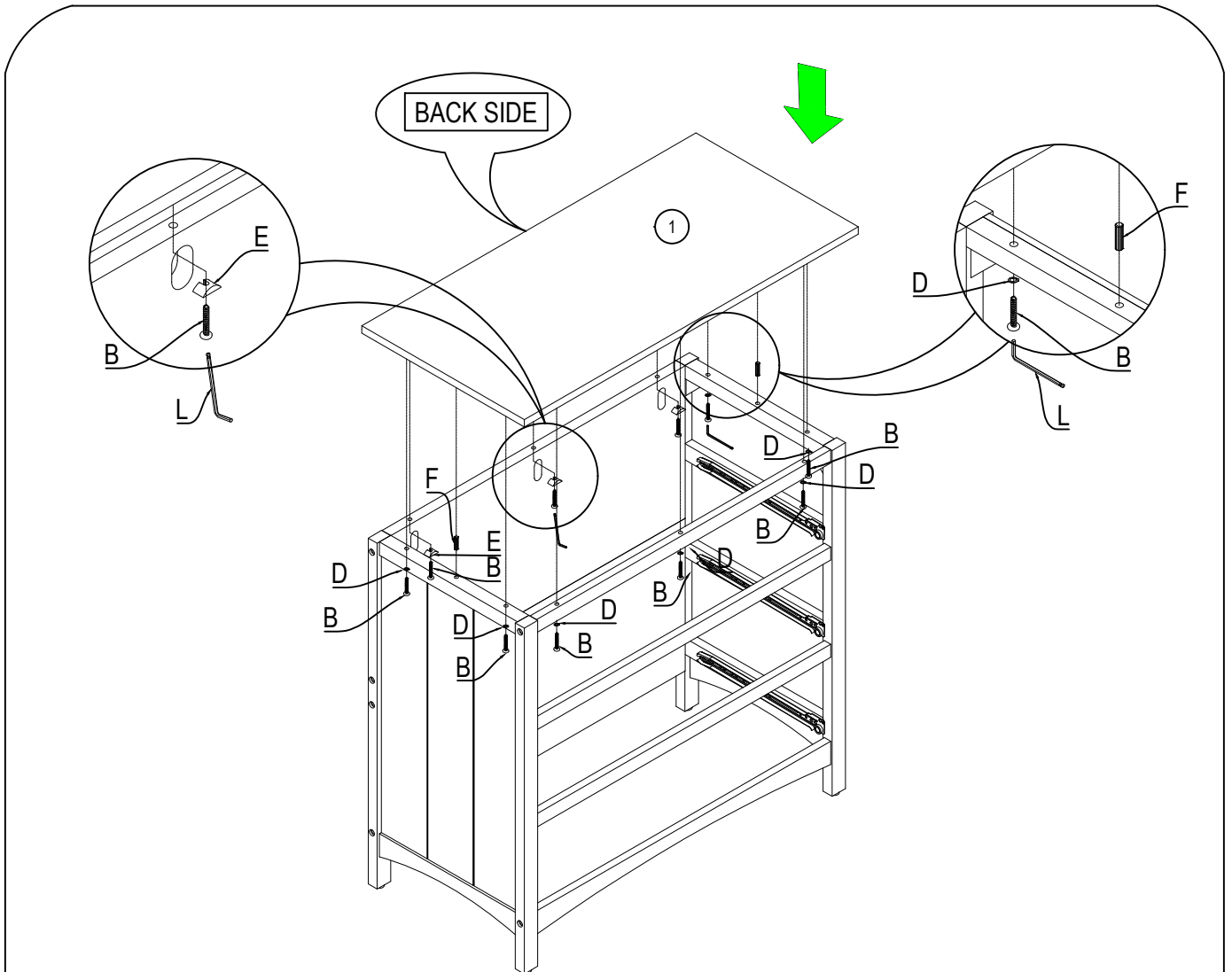
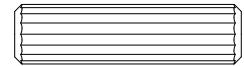

### STEP 3 :

- Flip up the dresser.
- Insert Dowel (F) into the top of both sides.
- Align Top panel (1) with the dowels.
- Attach Top panel (1) to top front rail and both sides by using Allen bolt (B), Spring washer (D). Tighten all bolts with Allen key (L).
- Attach Top panel (1) to back panel by using Allen bolt (B), Crescent washer (E). Tighten all bolts with Allen key (L).

## STEP 4 " ASSEMBLY OF DRAWER"

### THIS STEP REQUIRES :

- 9. Top drawer front (1 pc)
- 10. Bottom drawer front (2 pcs)
- 11. Drawer left side (3 pcs)
- 12. Drawer right side (3 pcs)
- 13. Drawer back (3 pcs)
- 14. Drawer bottom panel (3 pcs)
- 15. Drawer support (3 pcs)

(H) Screw 1" (25 mm) (30 pcs)

(K) Knob (4 pcs)

(J) Bolt 1" (25 mm) (4 pcs)

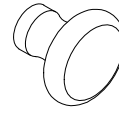
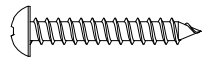

(G) Dowel Ø6x30mm (12 pcs)

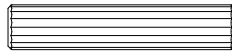

Screwdriver (not included)

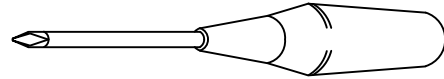

**STEP 4.1**

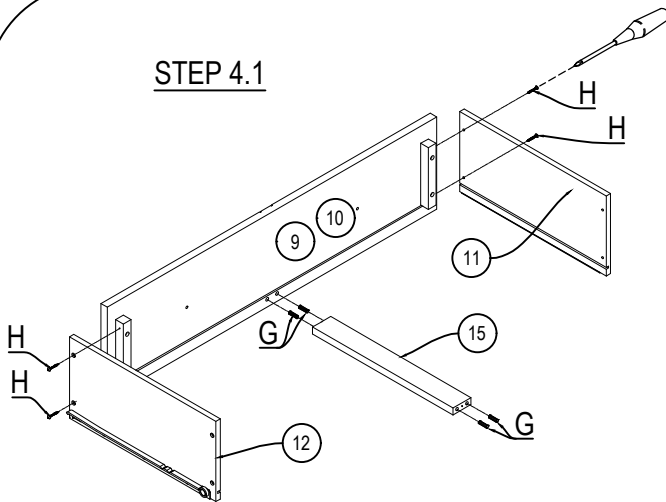

**STEP 4.3**

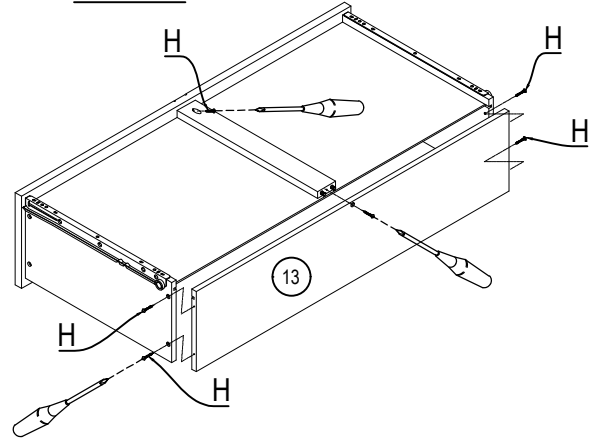

**STEP 4.2**

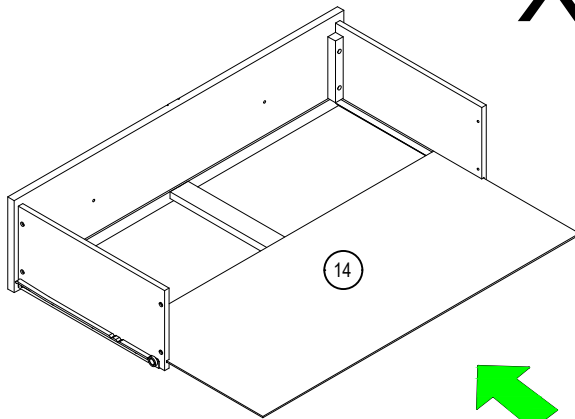

**X3**

**STEP 4.4**

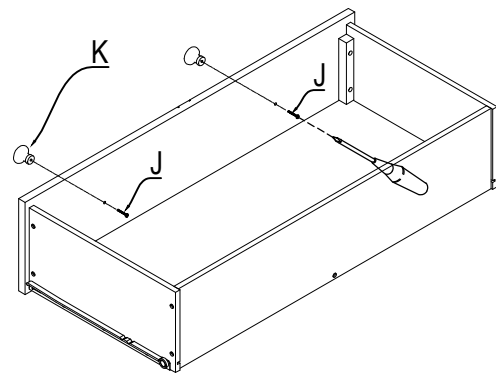

### **STEP 4.1 :**

Attach Drawer left side (11) and Drawer right side (12) to Drawer front (9)(10) with Screws (H). Tighten with the Screwdriver (not included). Attach Drawer support (15) into drawer front with Dowel (G).

### **STEP 4.2 :**

Slide Drawer bottom panel (14) in the grooves on the drawer left side and drawer right side, into the groove on the drawer front.

### **STEP 4.3 :**

Attach Drawer back (13) to drawer side ends with Screws (H). Tighten drawer support to drawer front and drawer back with screw (H). Tighten with the Screwdriver (not included).

### **STEP 4.4 :**

Attach Knob (K) to drawer front with Bolt (J). Tighten with the Screwdriver (not included).

## STEP 5 " ASSEMBLY OF DRAWER"

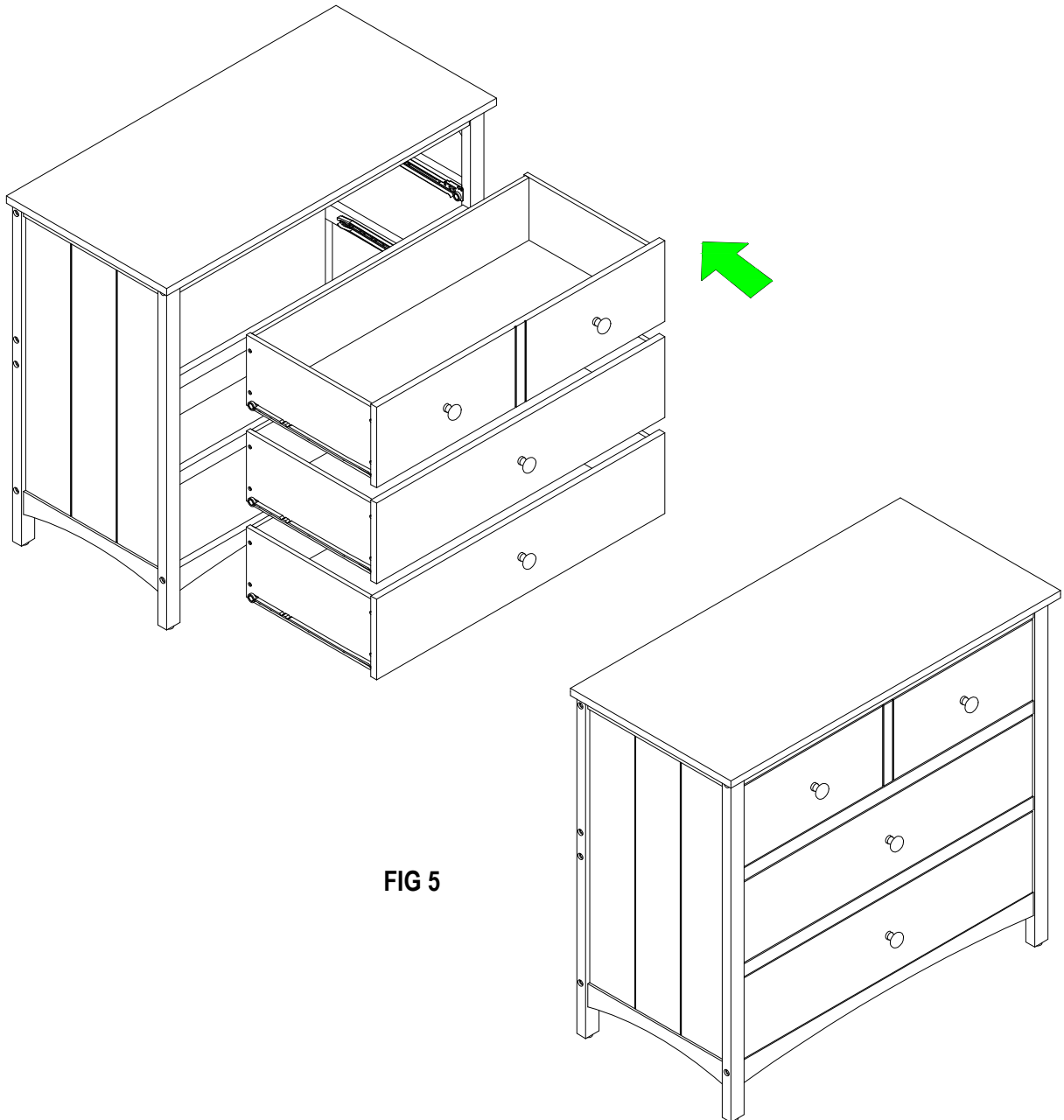

FIG 5

**STEP 5 :**

Assembly drawer box to the dresser as shown. Complete as shown in FIG 5. Thank you.