

# ASSEMBLY INSTRUCTIONS

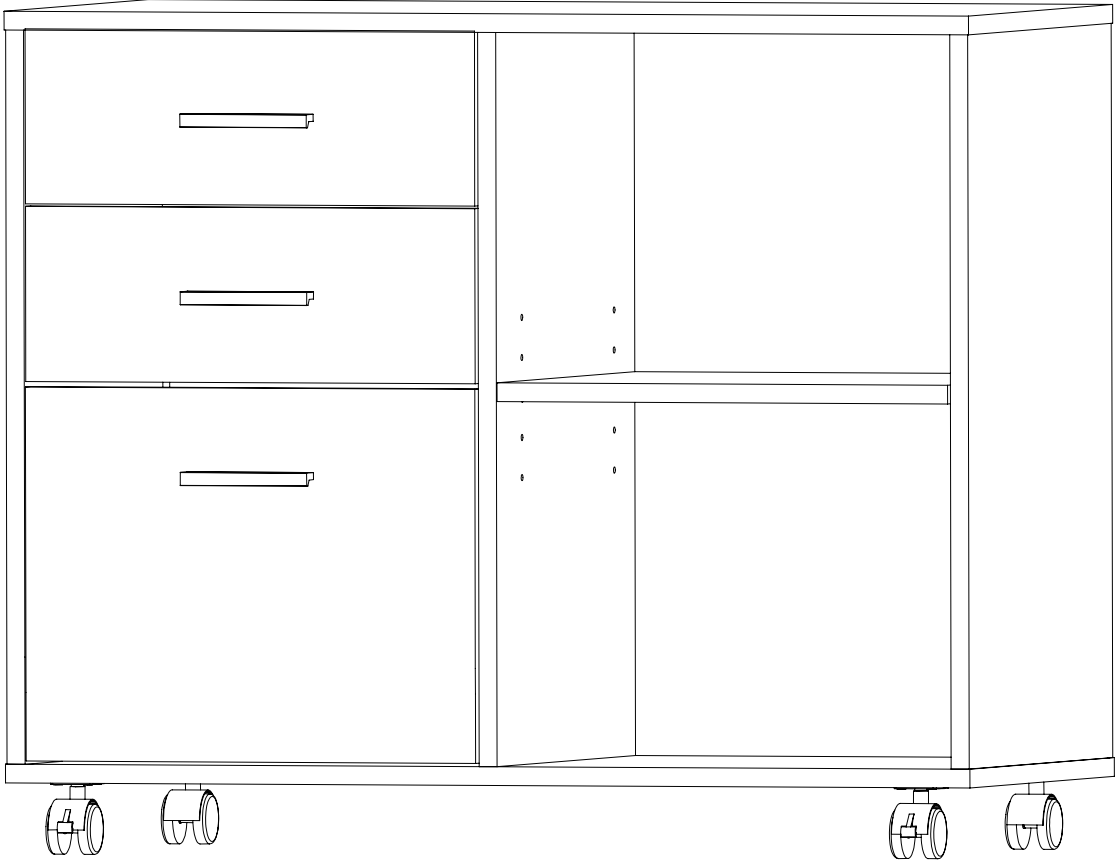

## Tools Required For Assembly

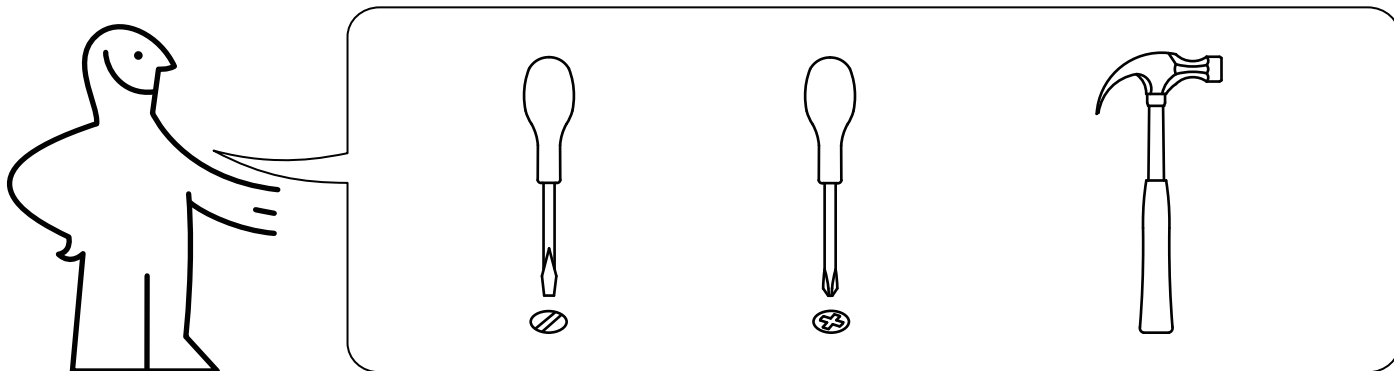

## Need Two Or More People To Complete

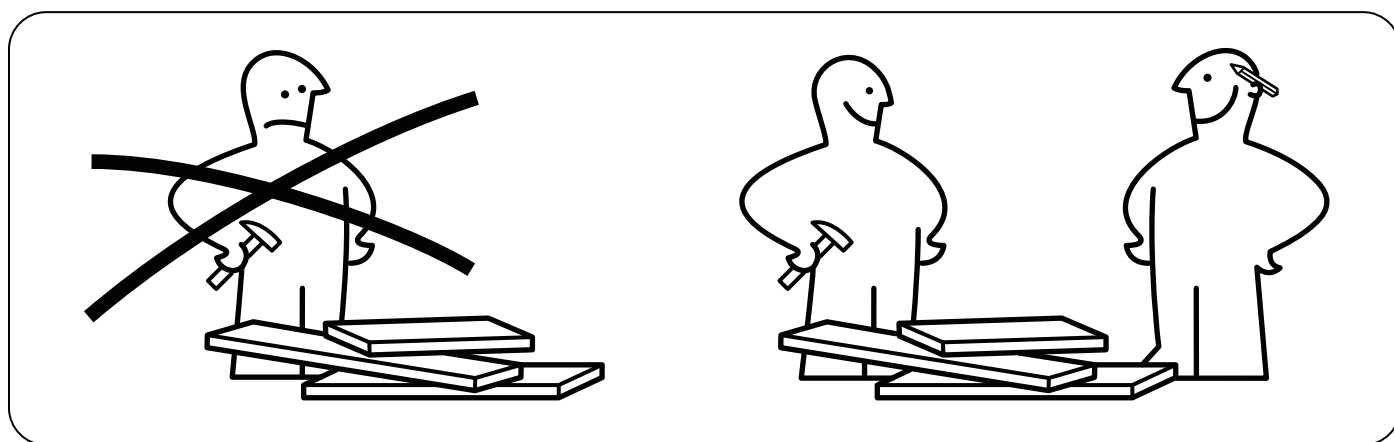

## Assemble Item On a Clean Flat Surface

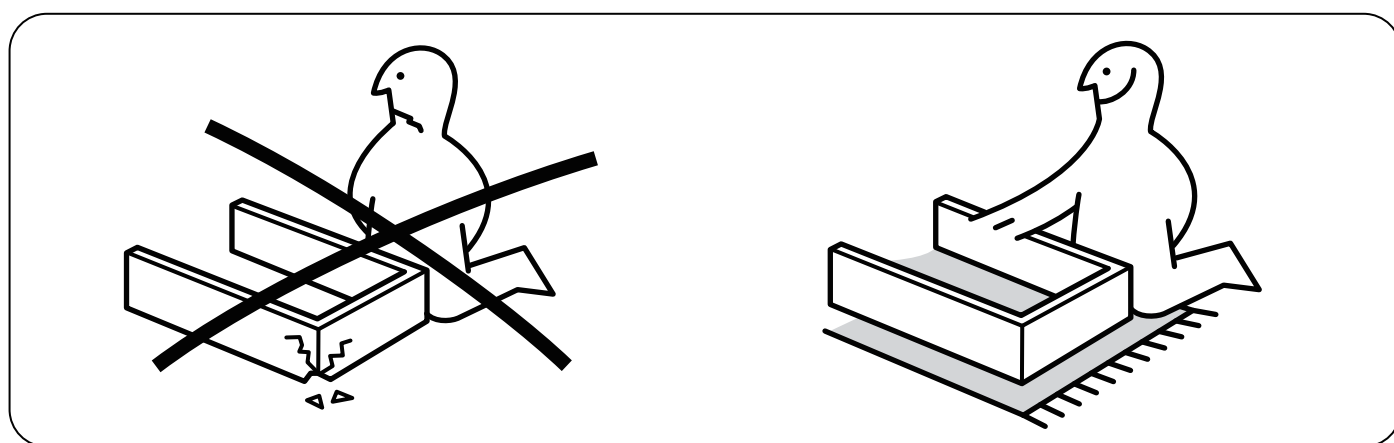

- Please check you have all hardware before assembling.
- Please ensure you have the name of the item and hardware part required and quantity.
- Enjoy your new purchase!

# EXPLODED DRAWING:

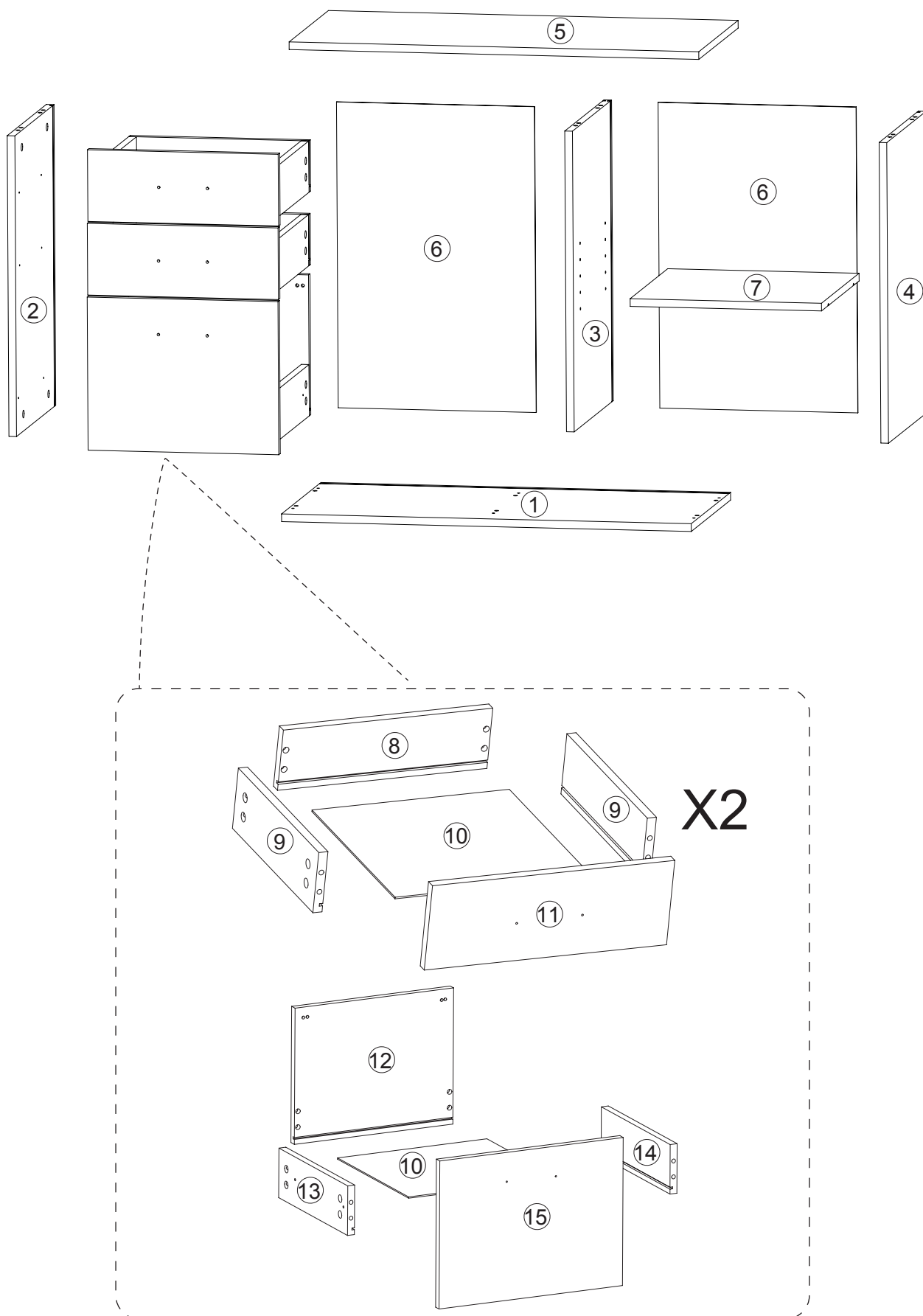

# PARTS:

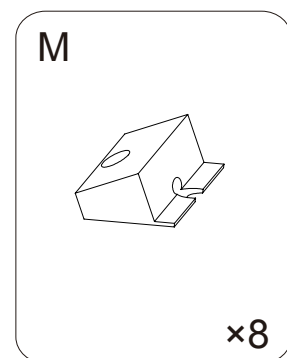
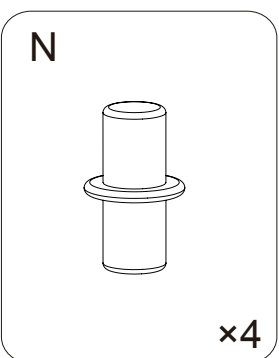
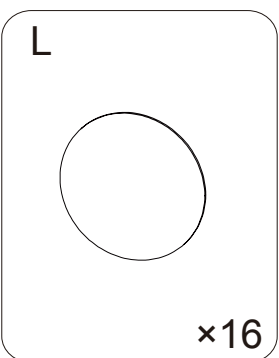
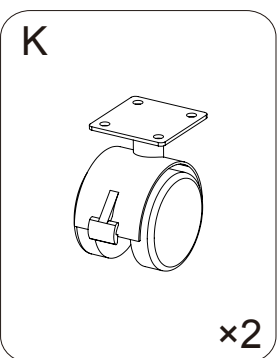
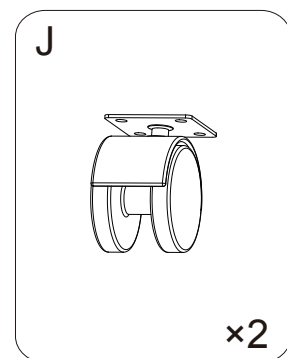
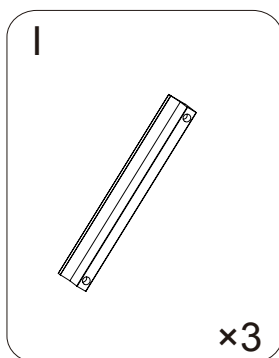
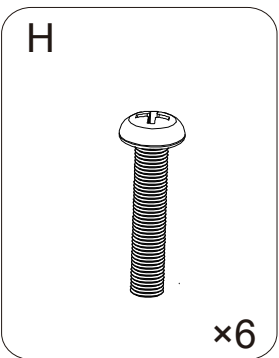
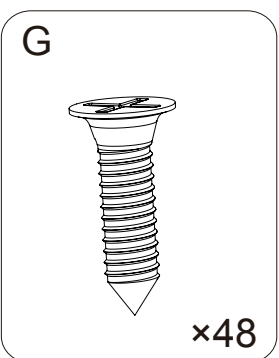
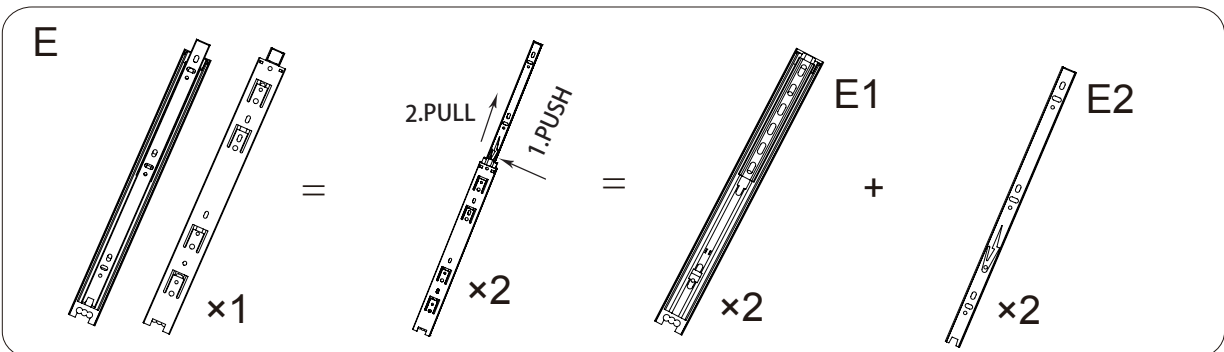
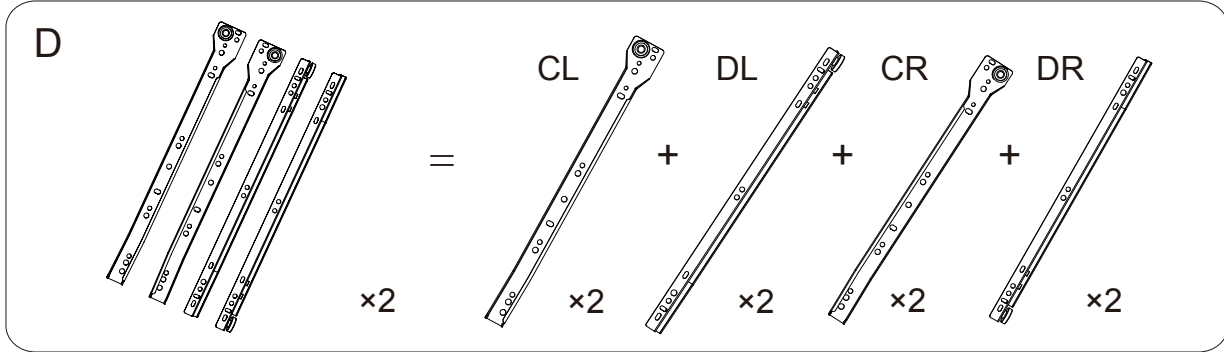
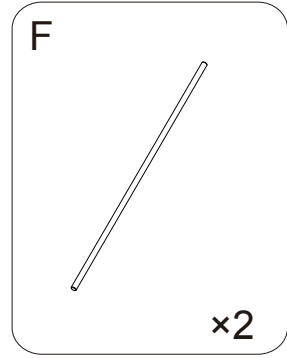
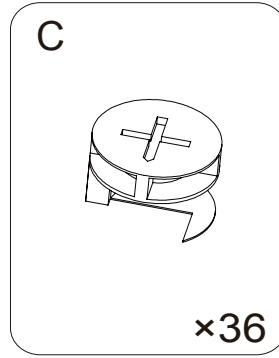
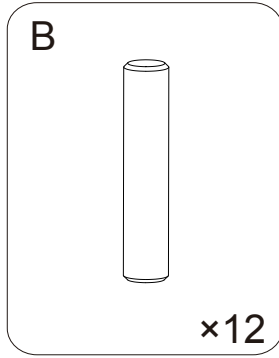
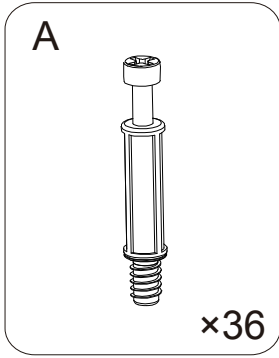

# REMARKS:

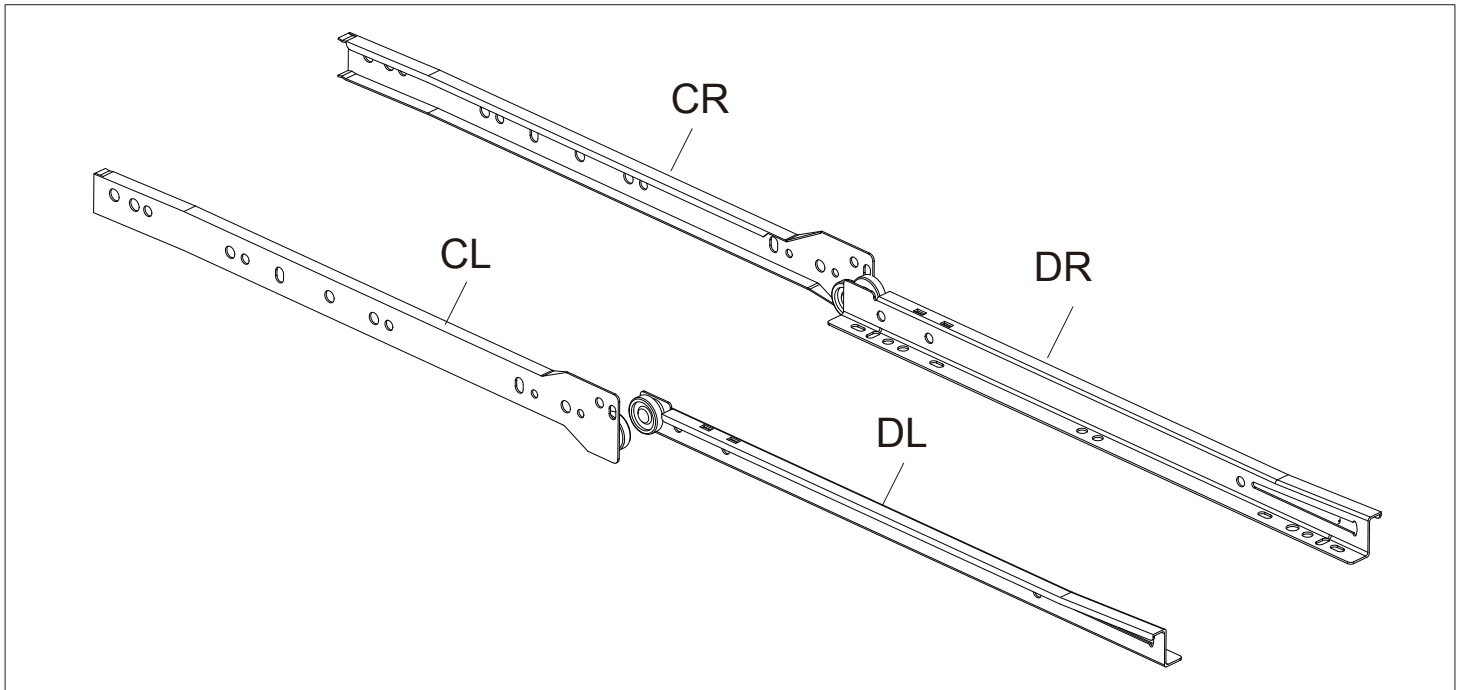

Press the plastic part in the indicated direction to separate drawer runner E1 and E2 before assembling.

**REMARK:**

Please grip the E1 part while sliding the E2 part.

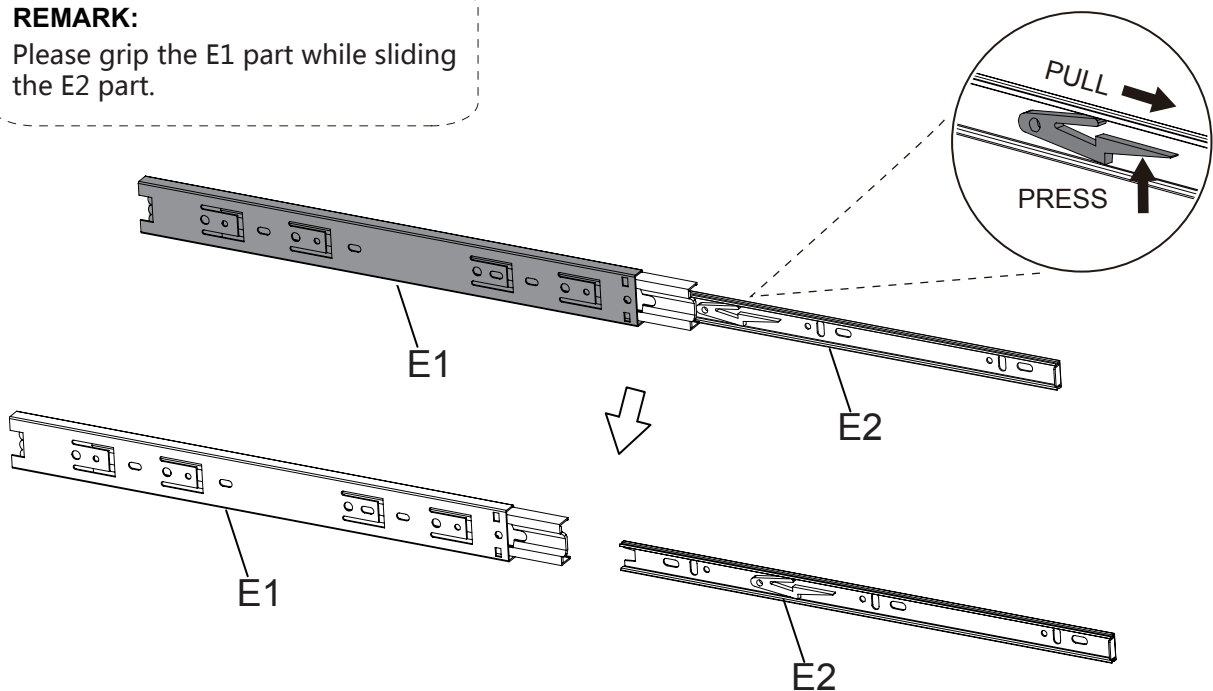

MINIFIX POSITION

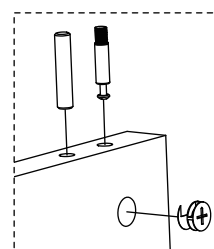

# 1.

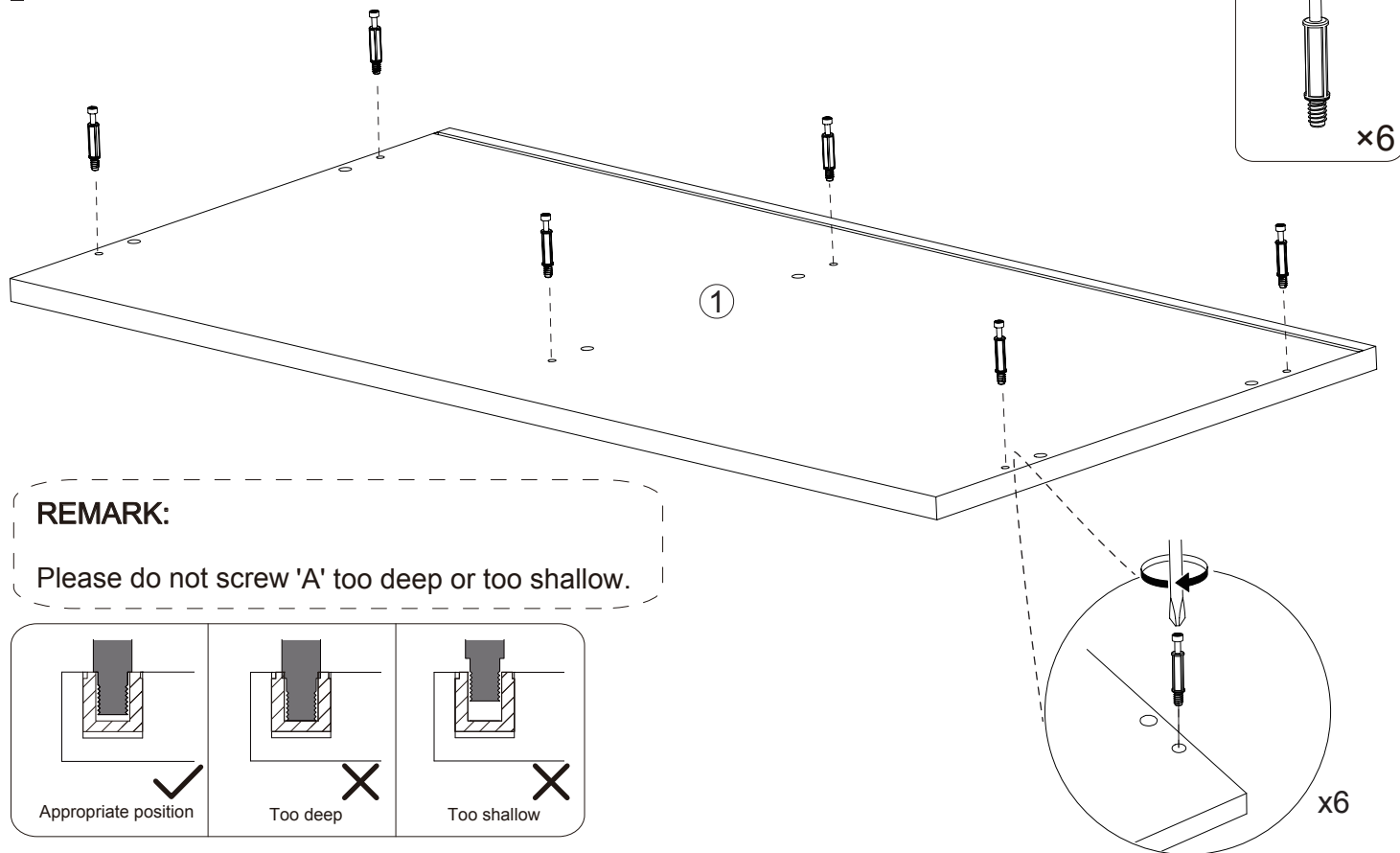

# 2.

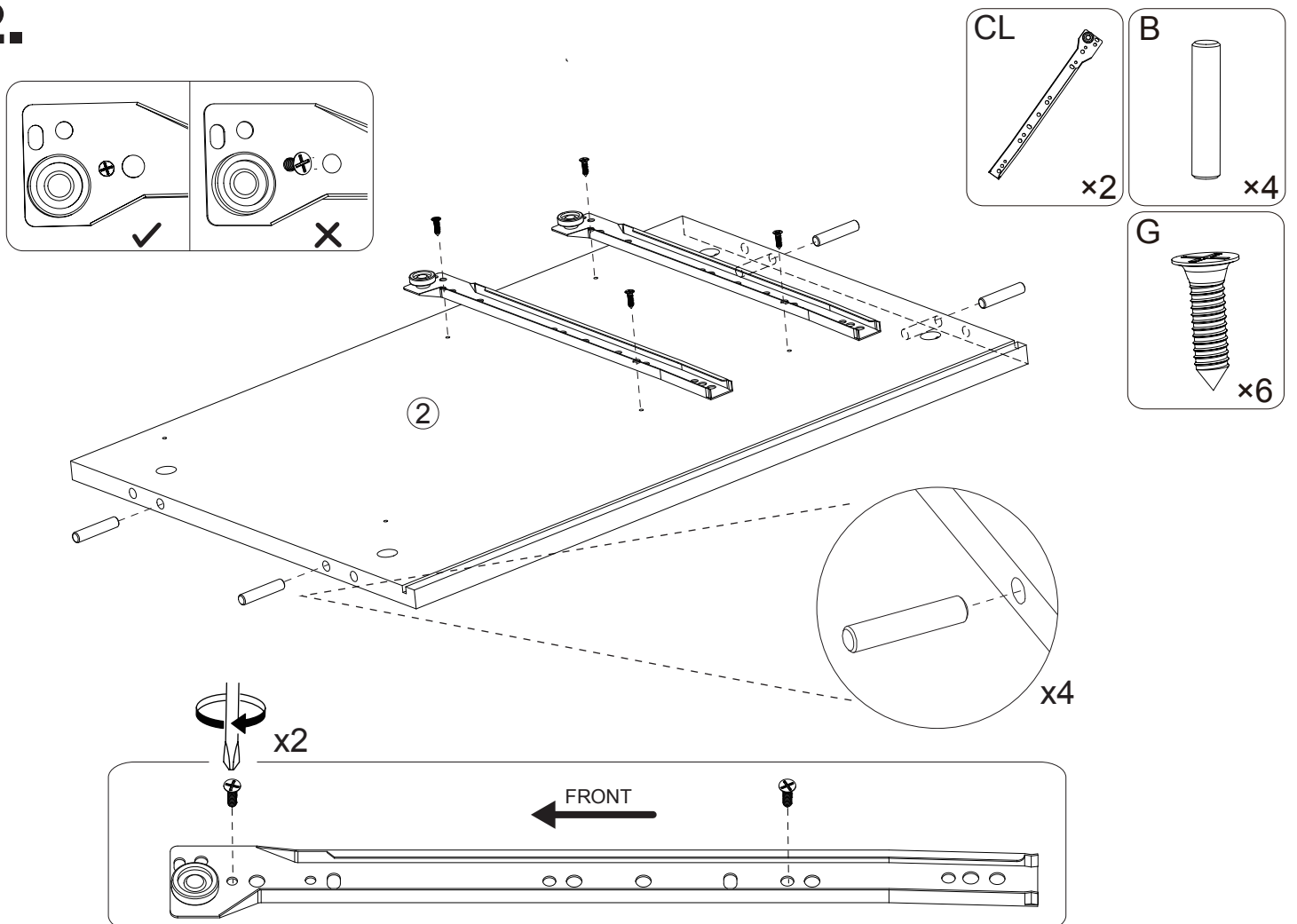

3.

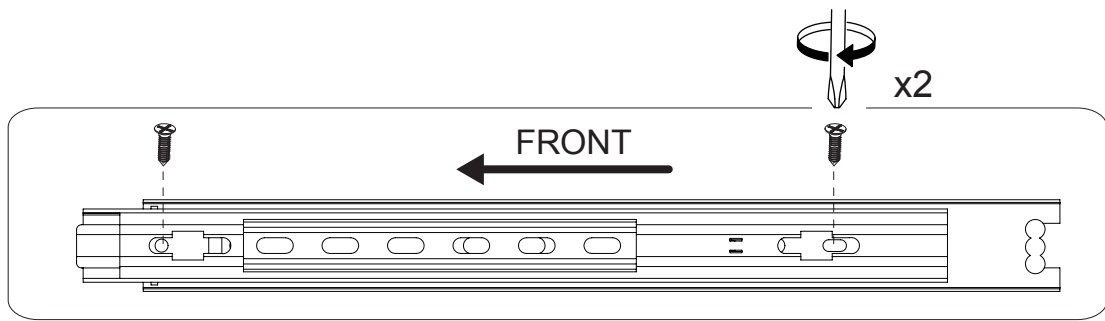
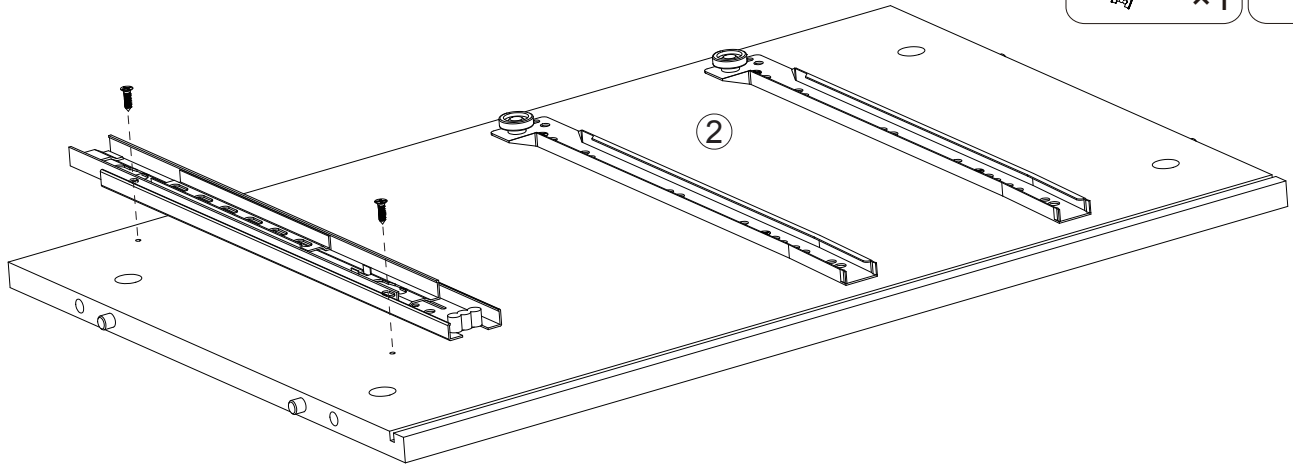
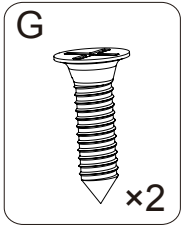

4.

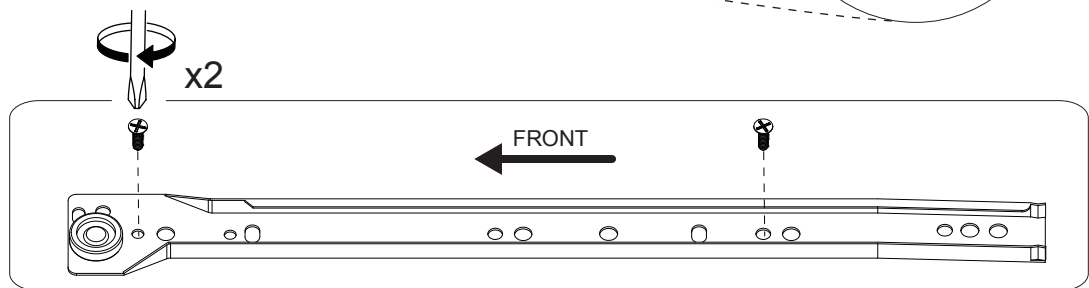
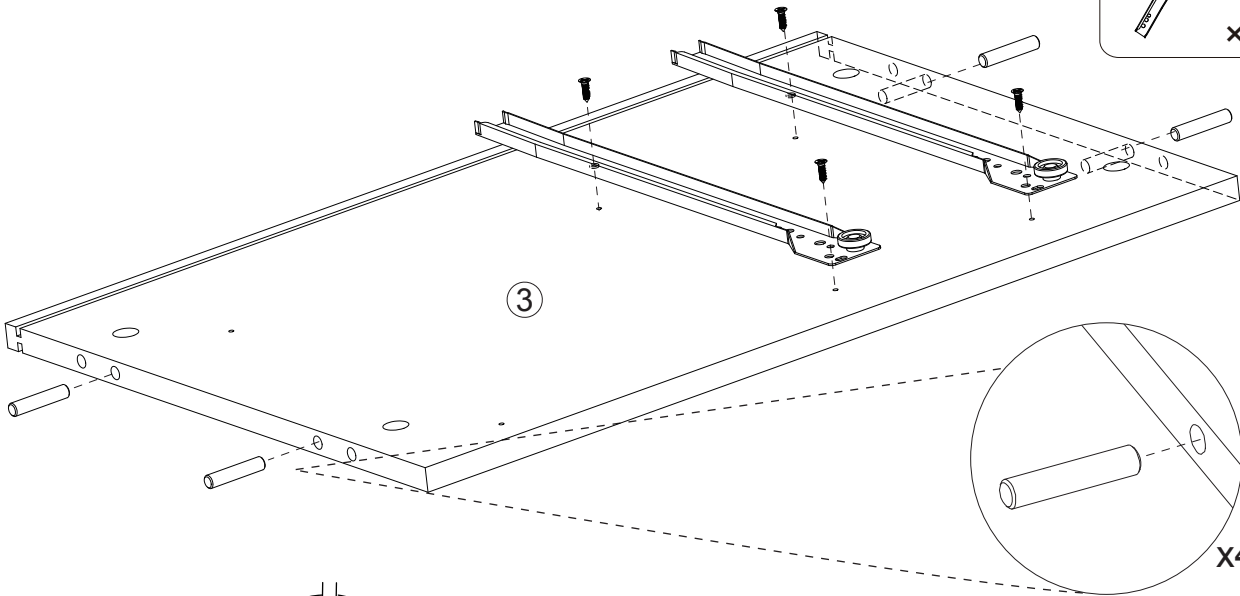
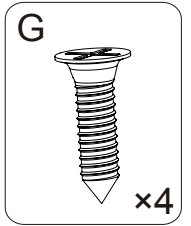
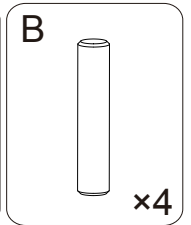
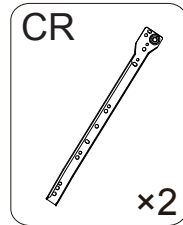

5.

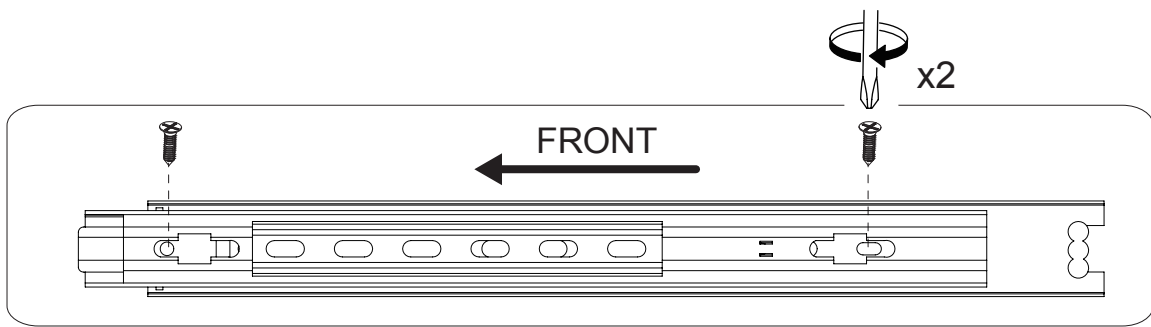
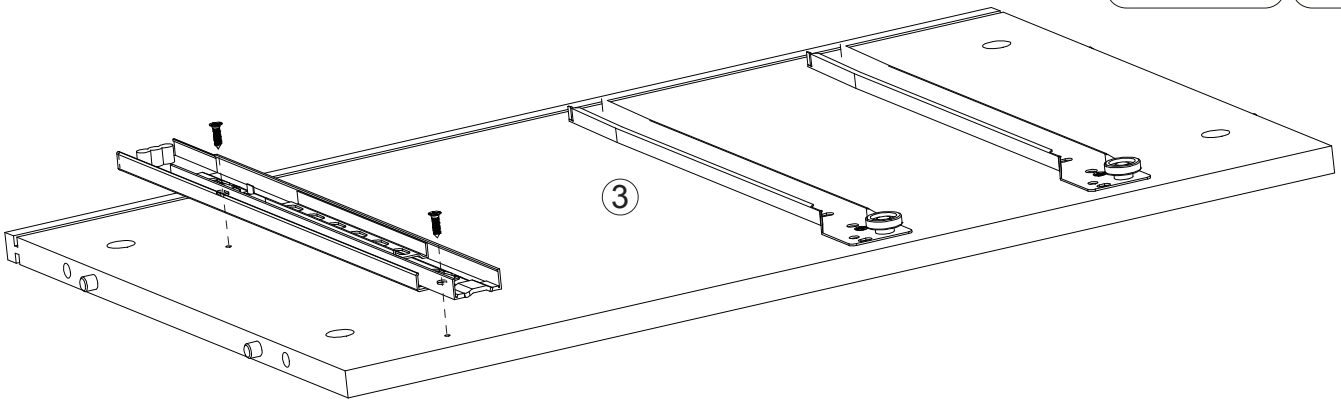
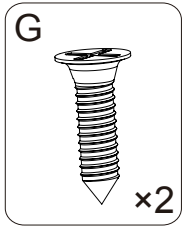
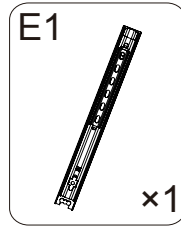

6.

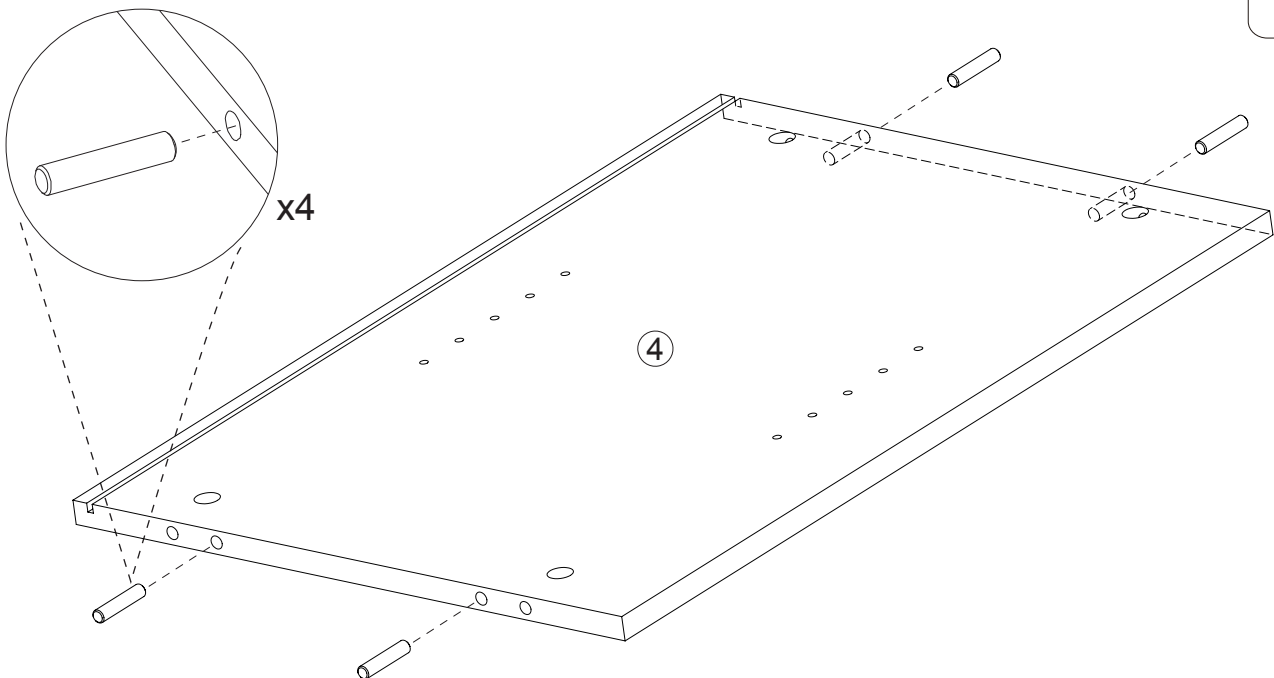
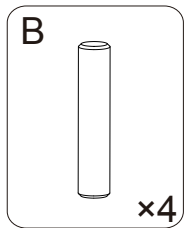

7.

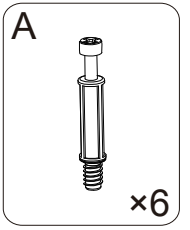
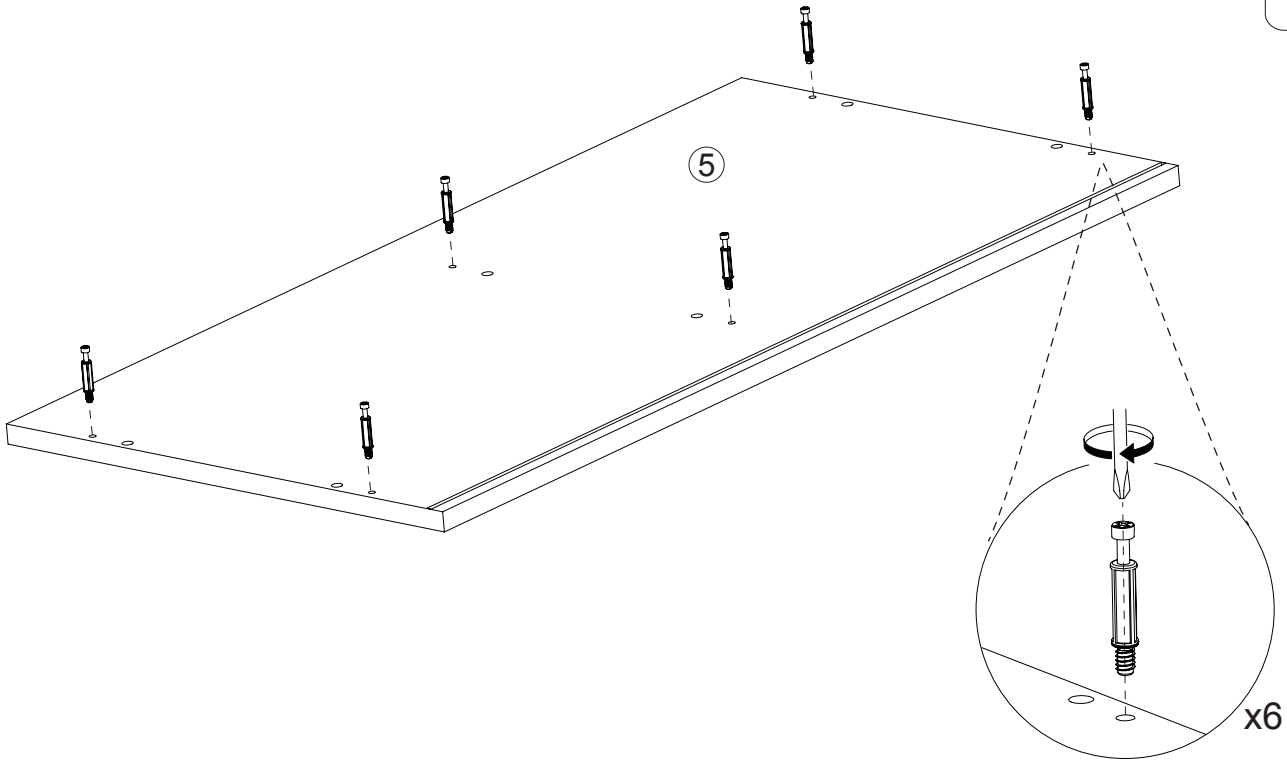

8.

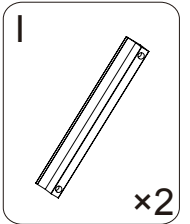
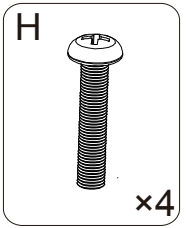
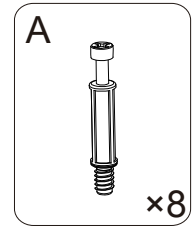
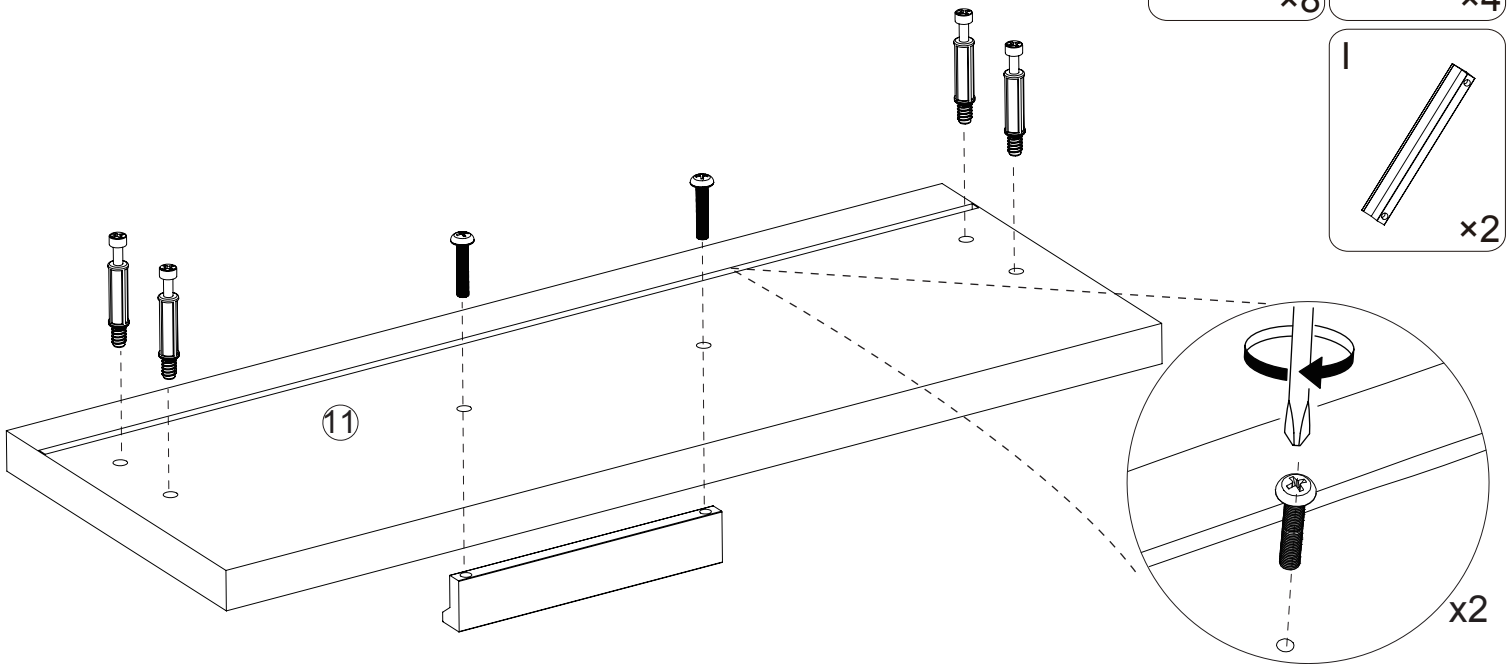

X2

9.

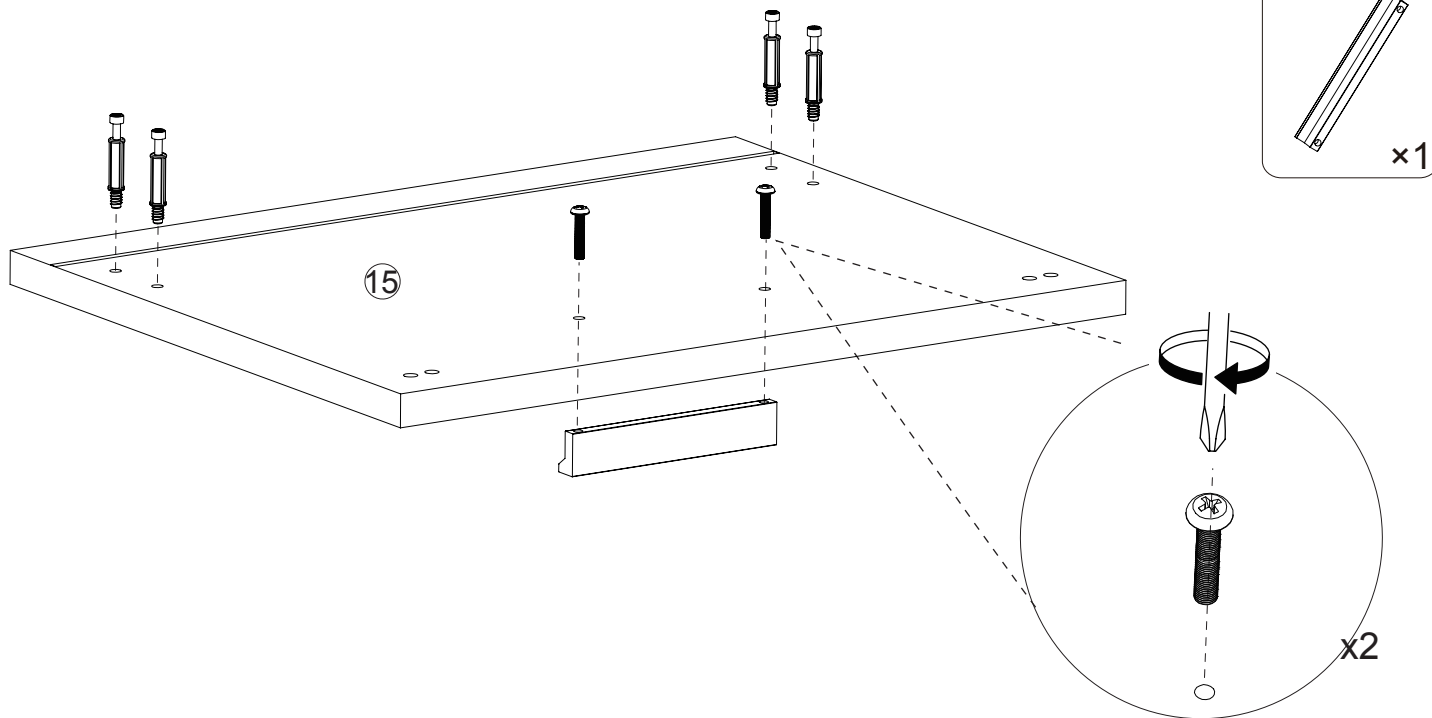

10.

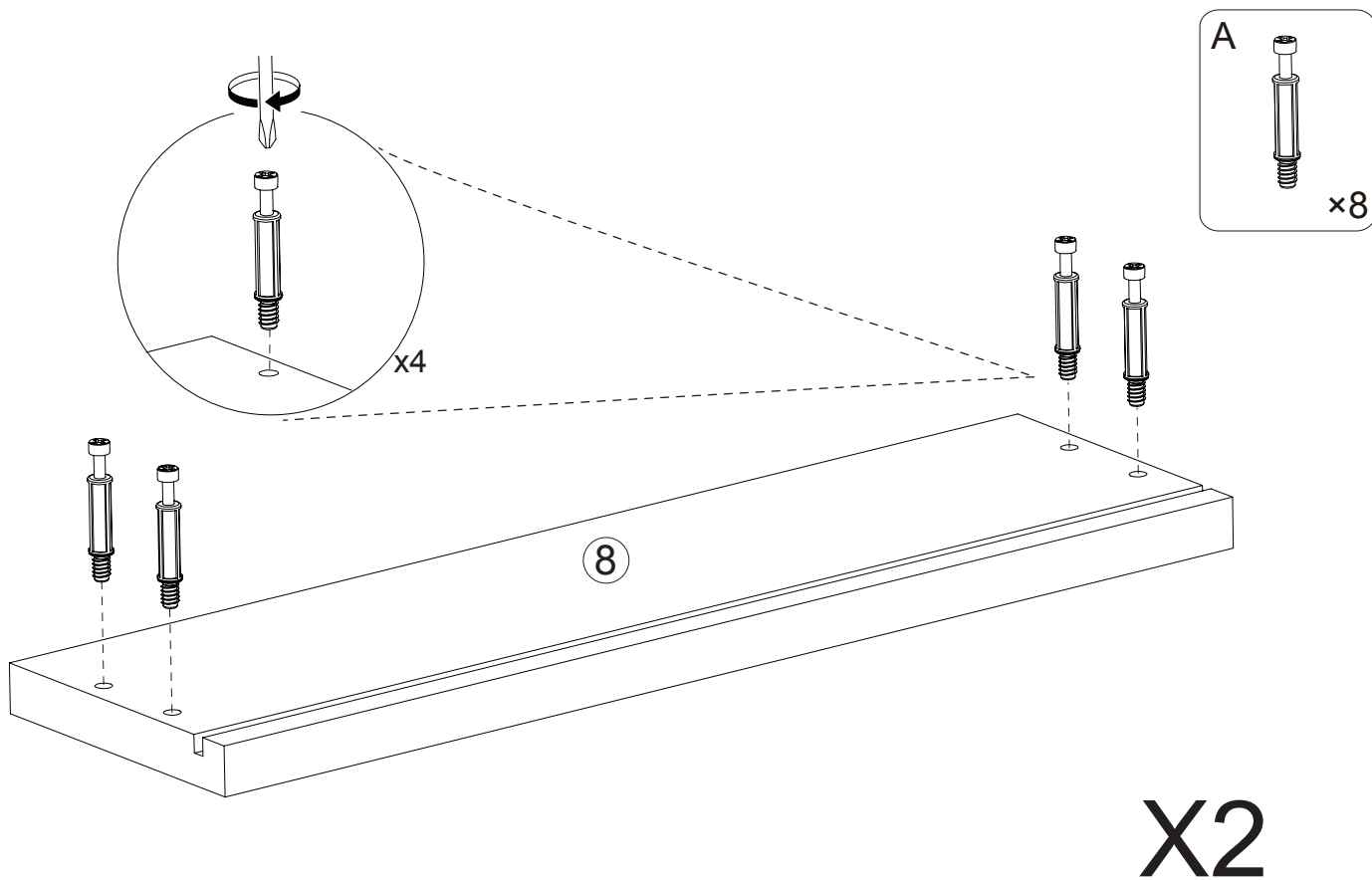

X2

11.

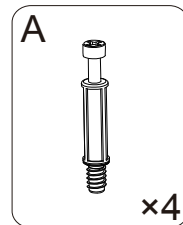
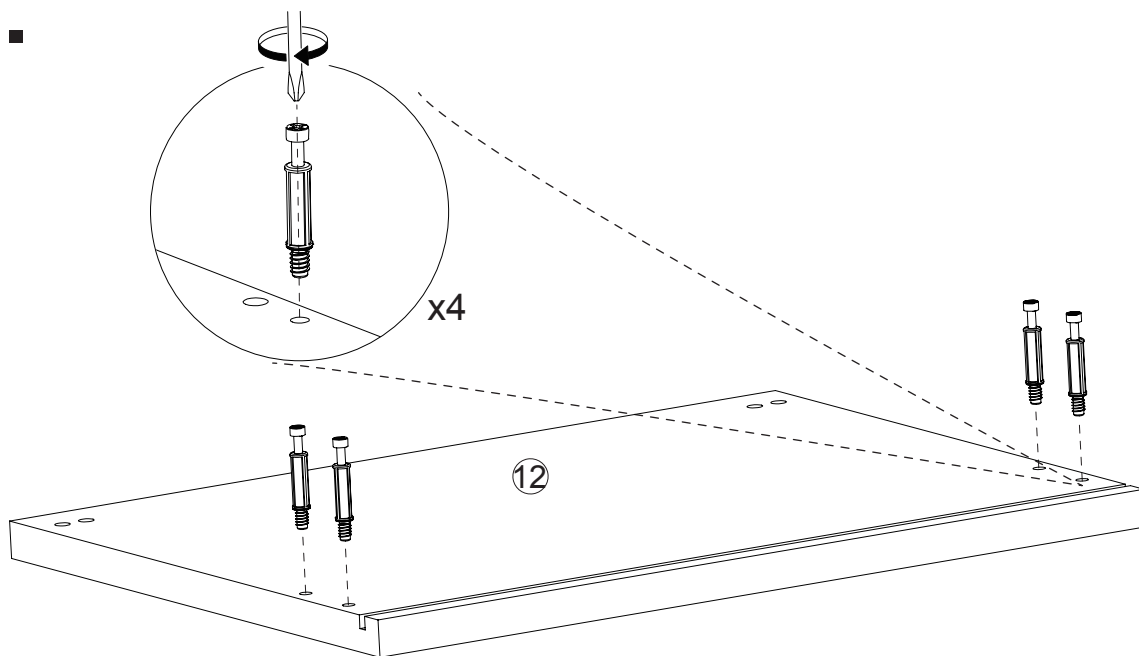

12.

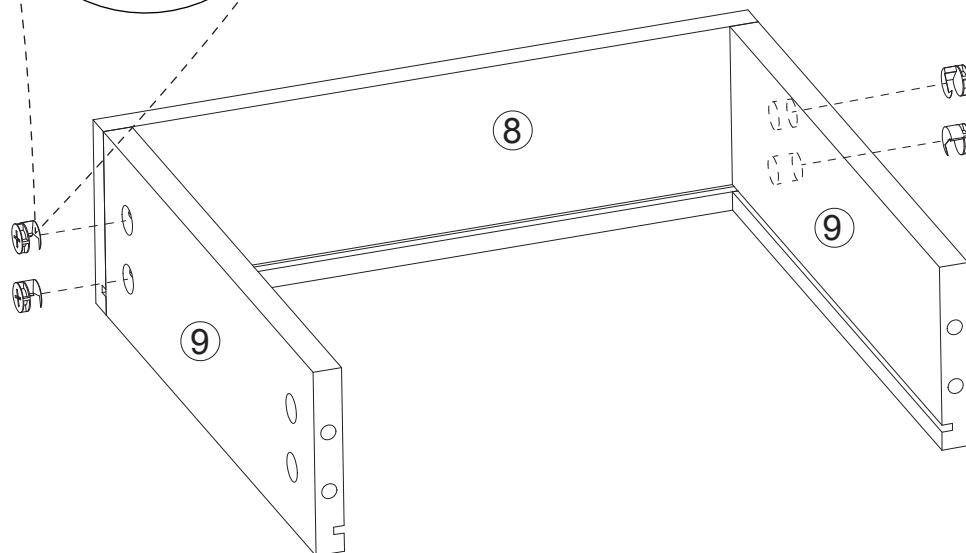
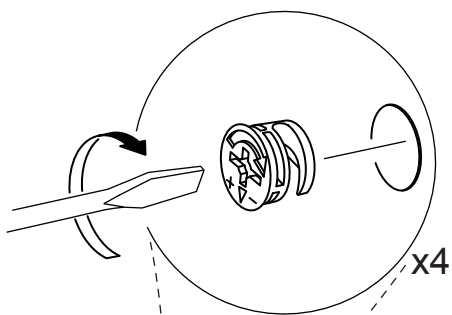
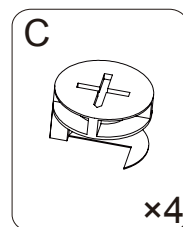
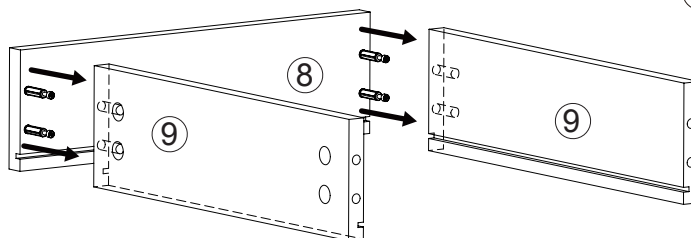
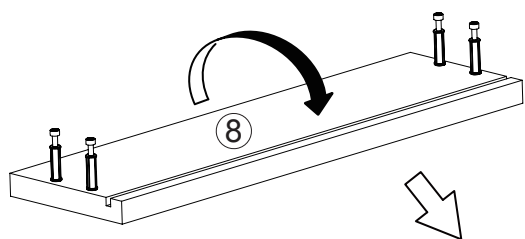

X2

**13.**

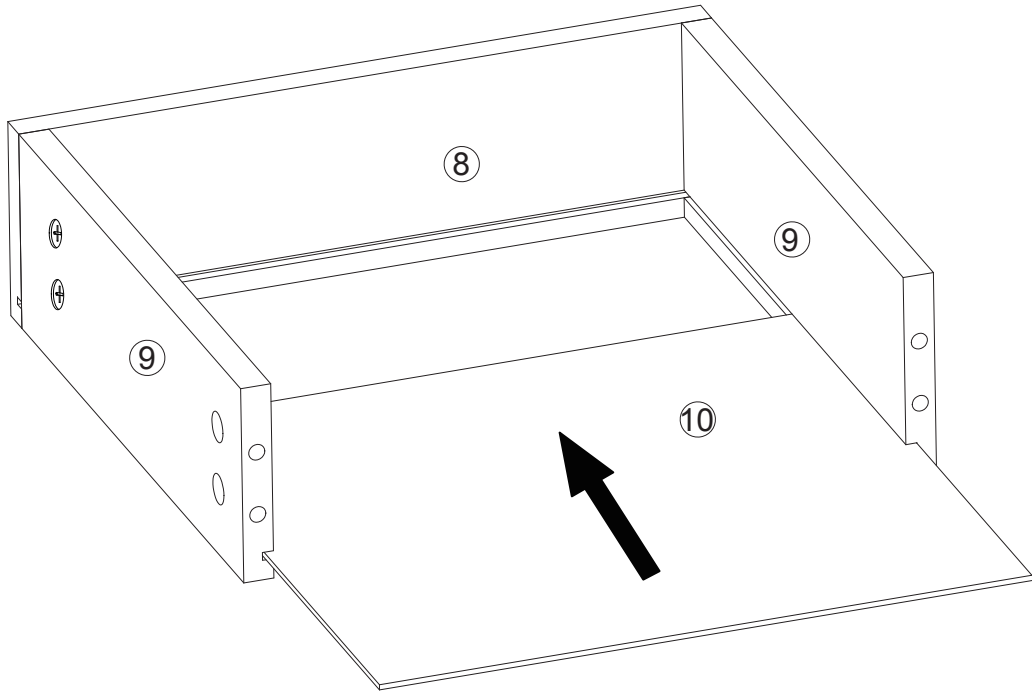

**X2**

**14.**

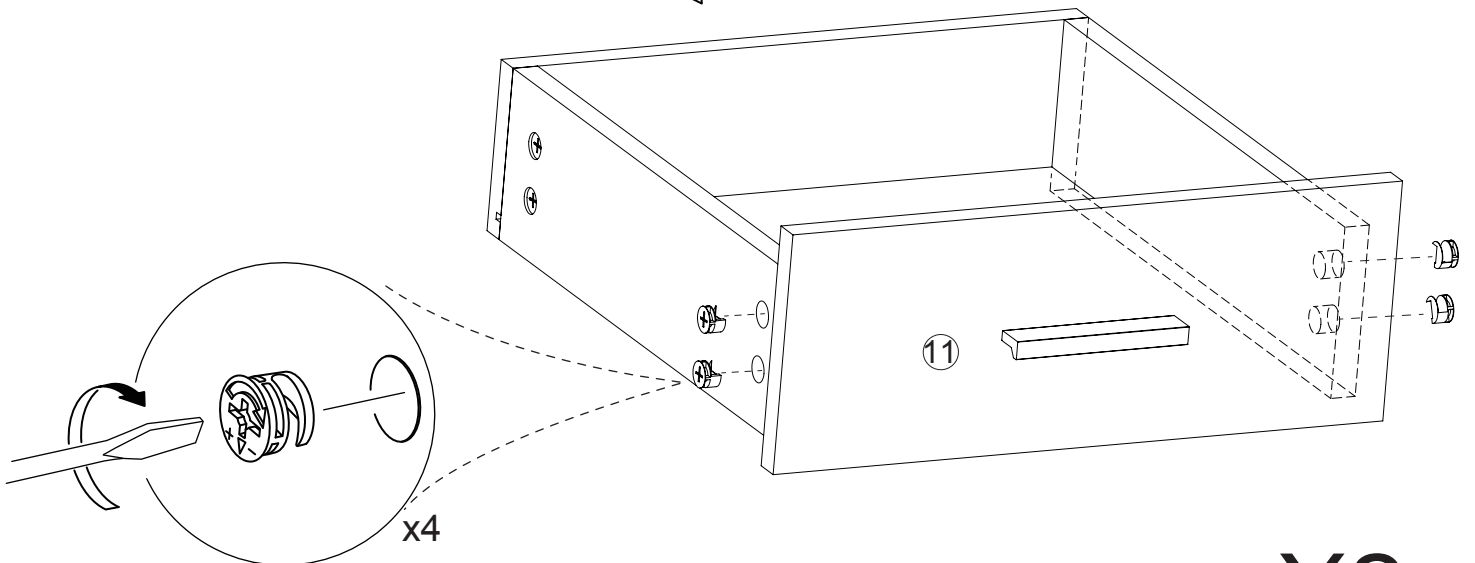
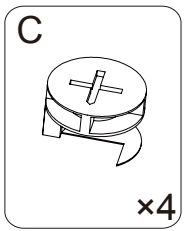
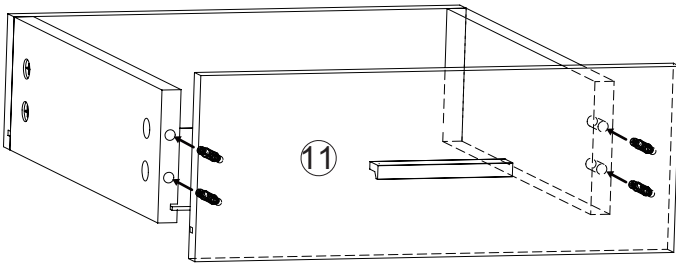

**X2**

15.

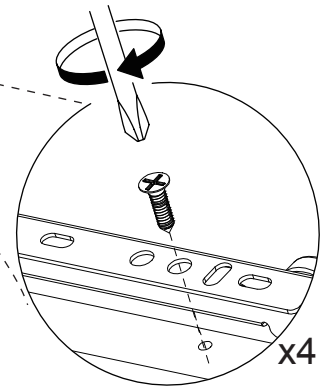
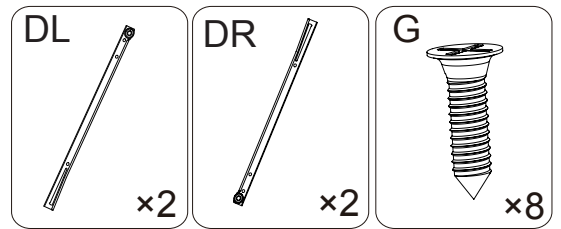
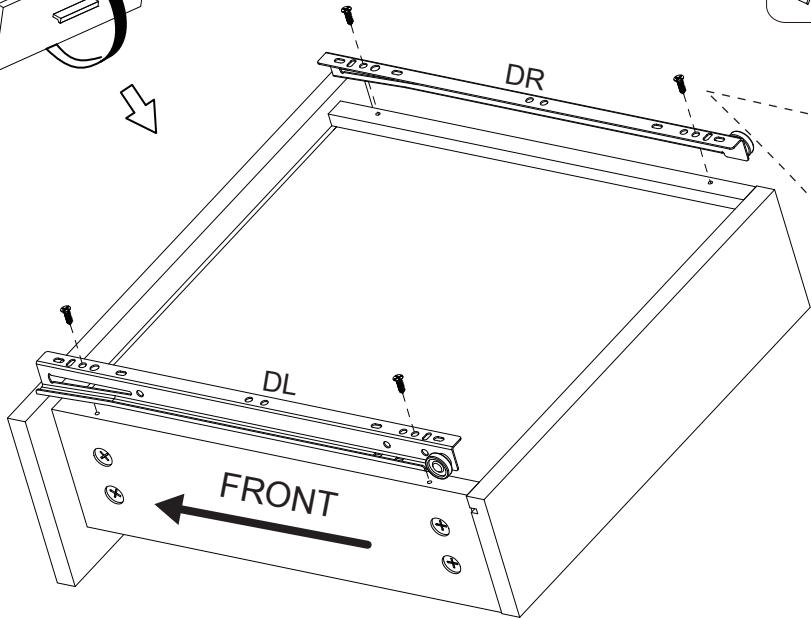
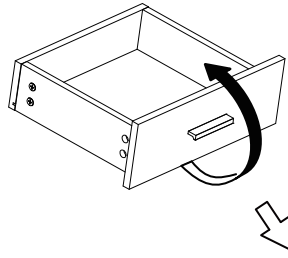

X2

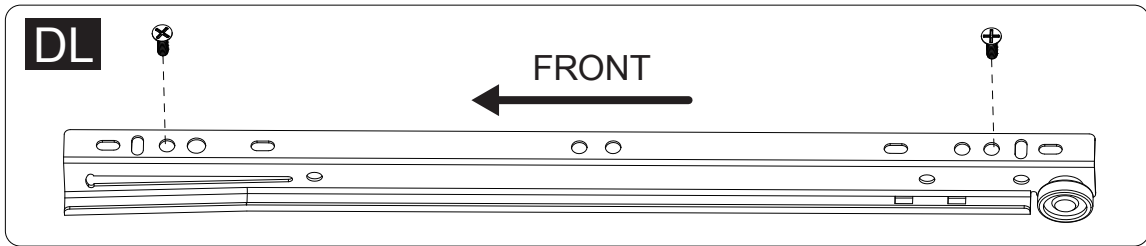

16.

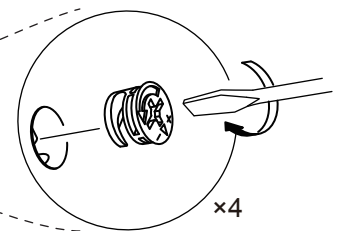
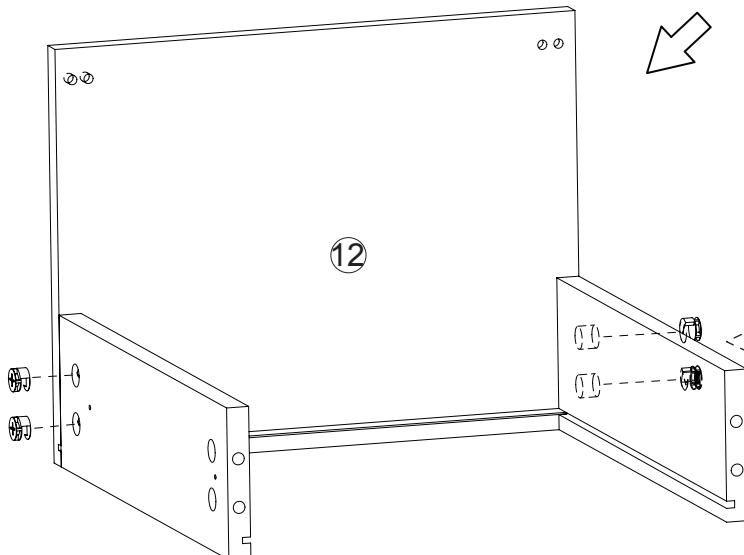
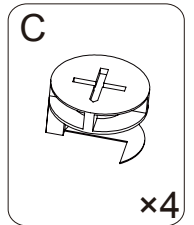
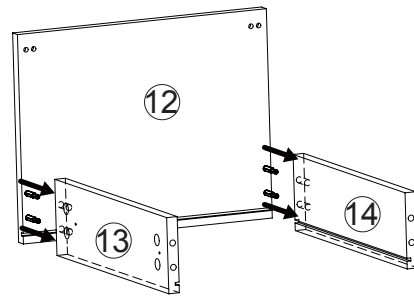
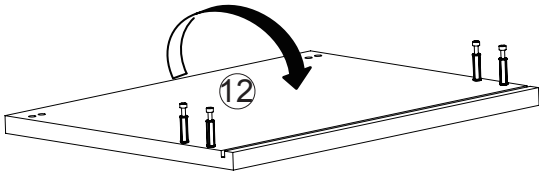

17.

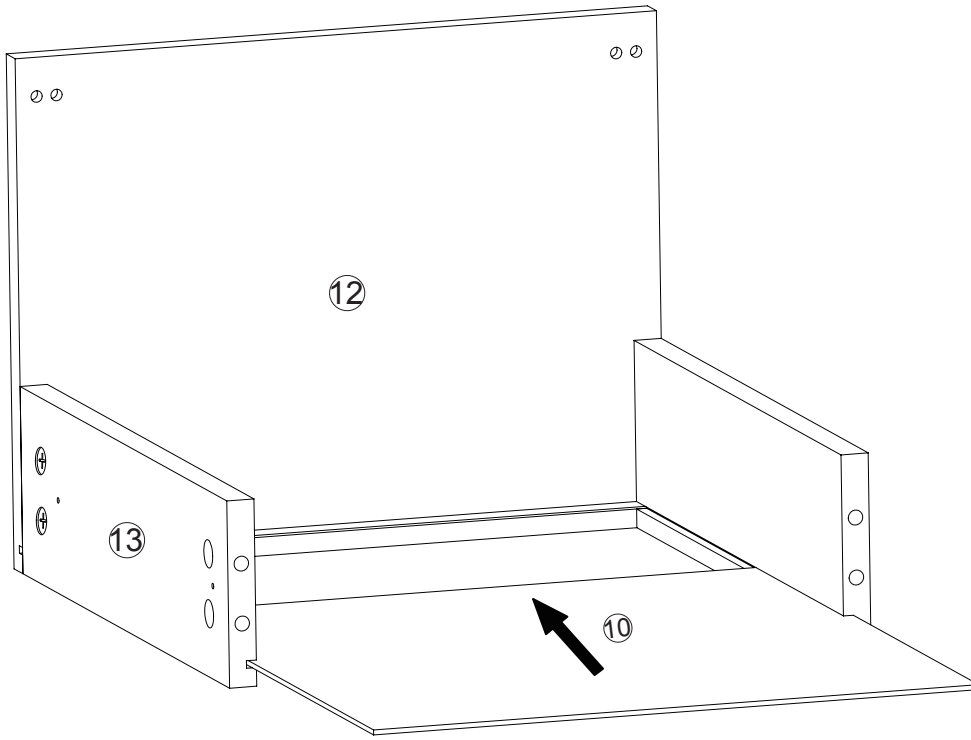

18.

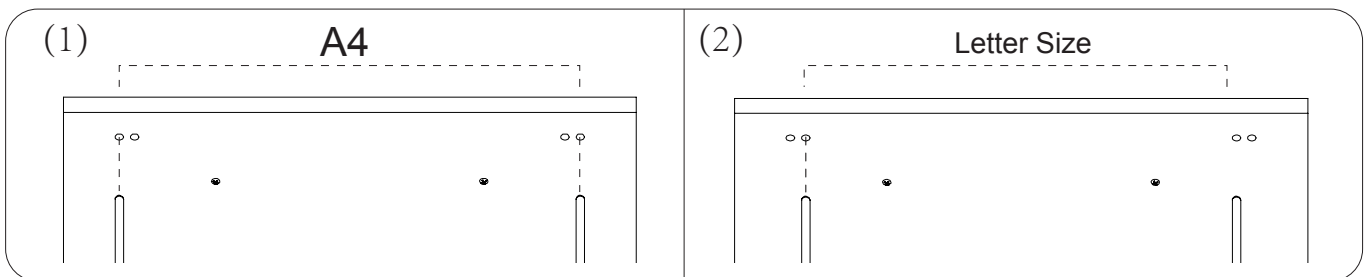
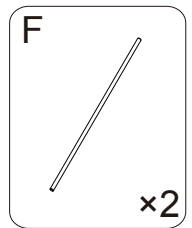
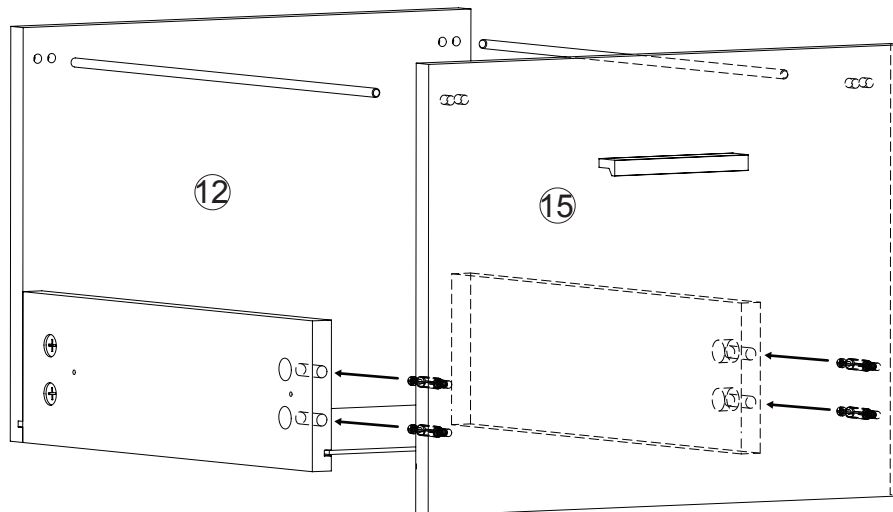

As shown in Fig. 1 installation method, the A4 Size file can be hung after installation.  
As shown in Fig. 2 installation method, the Letter Size file can be hung after installation.

19.

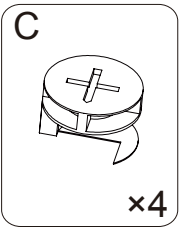
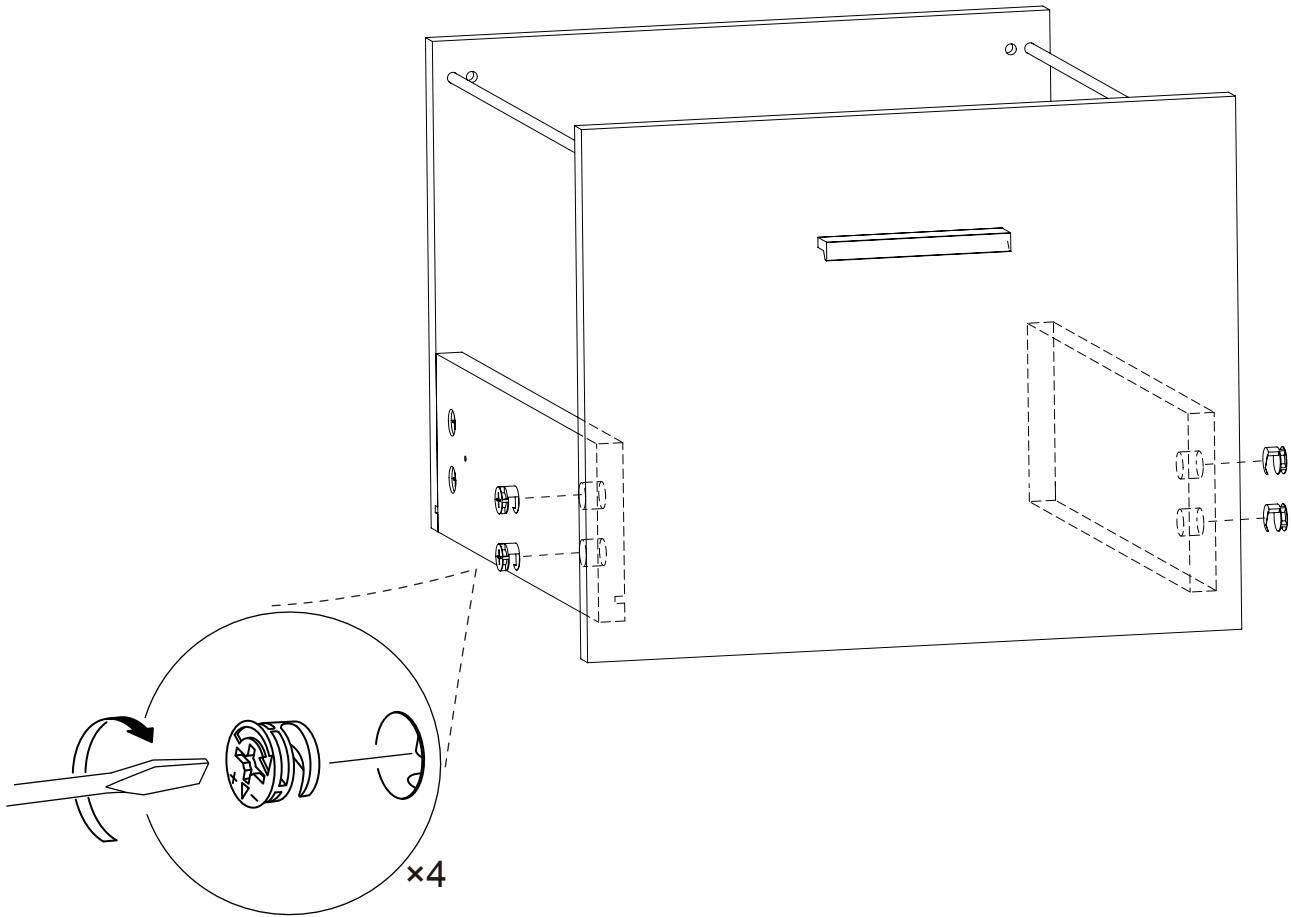

20.

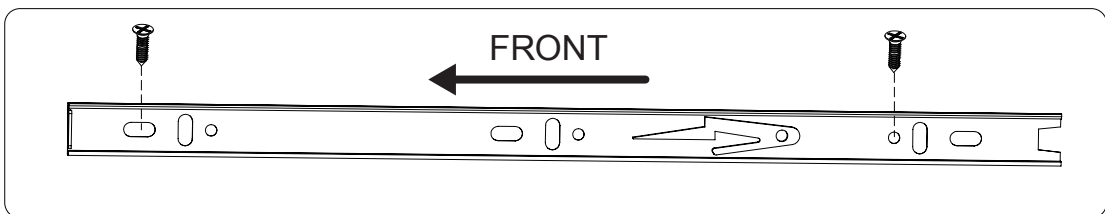
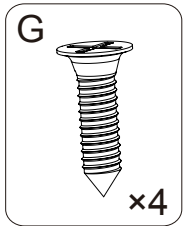
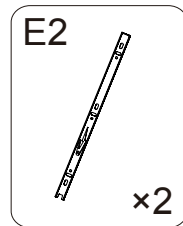
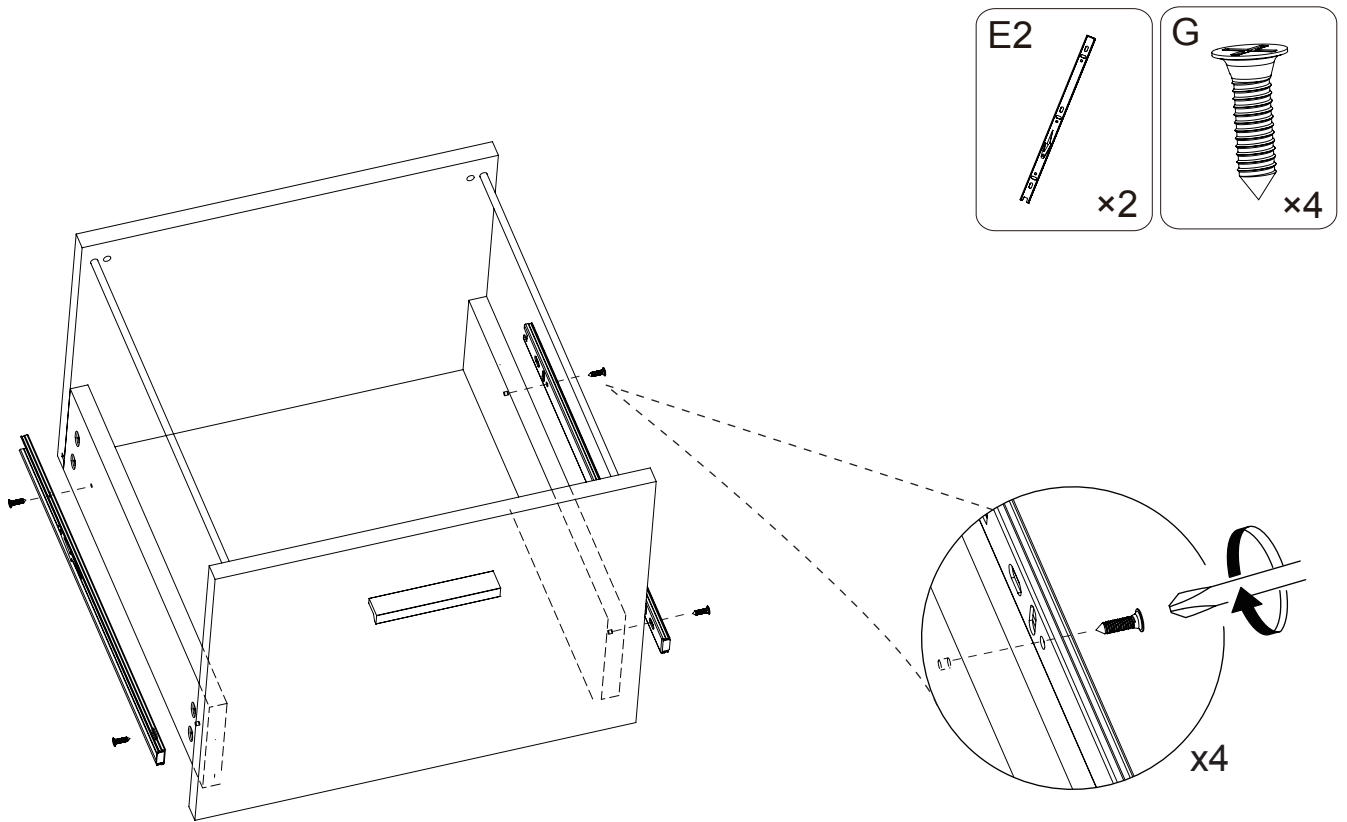

21.

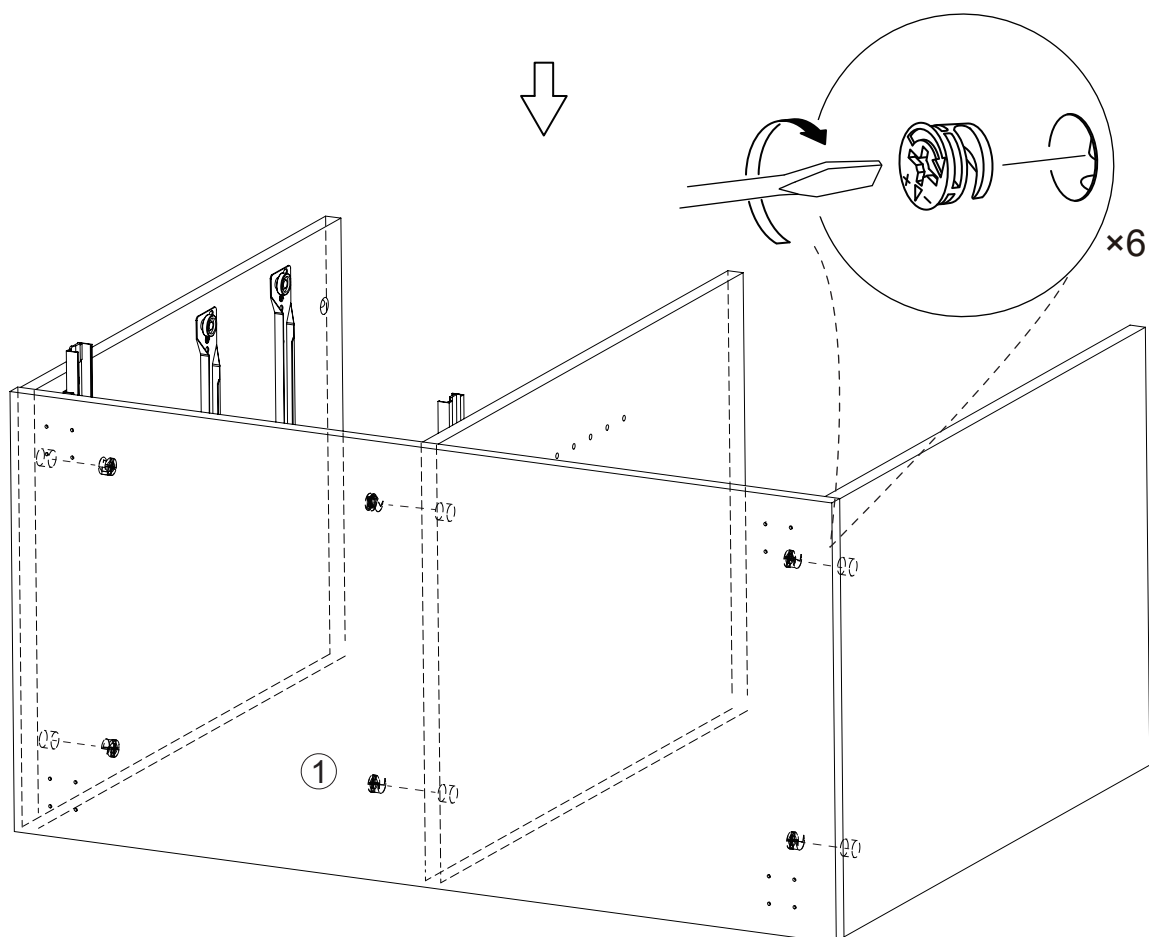
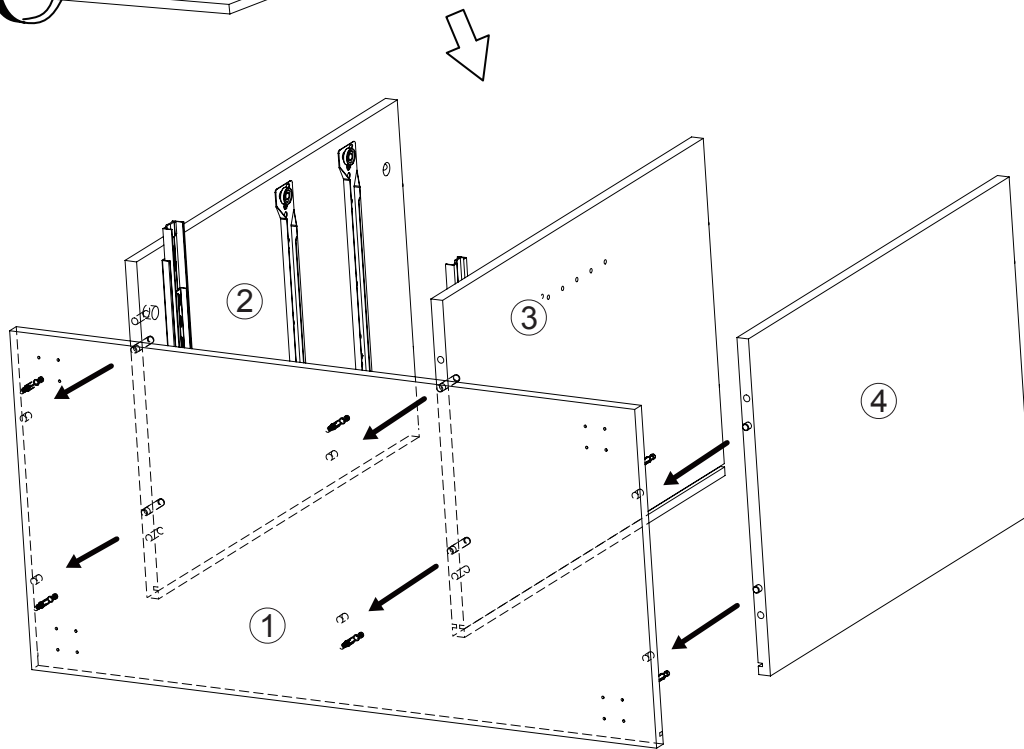
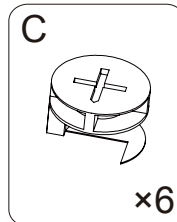
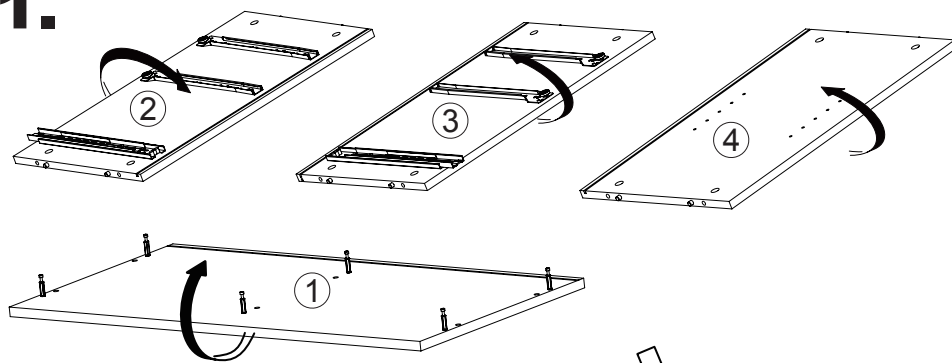

**22.**

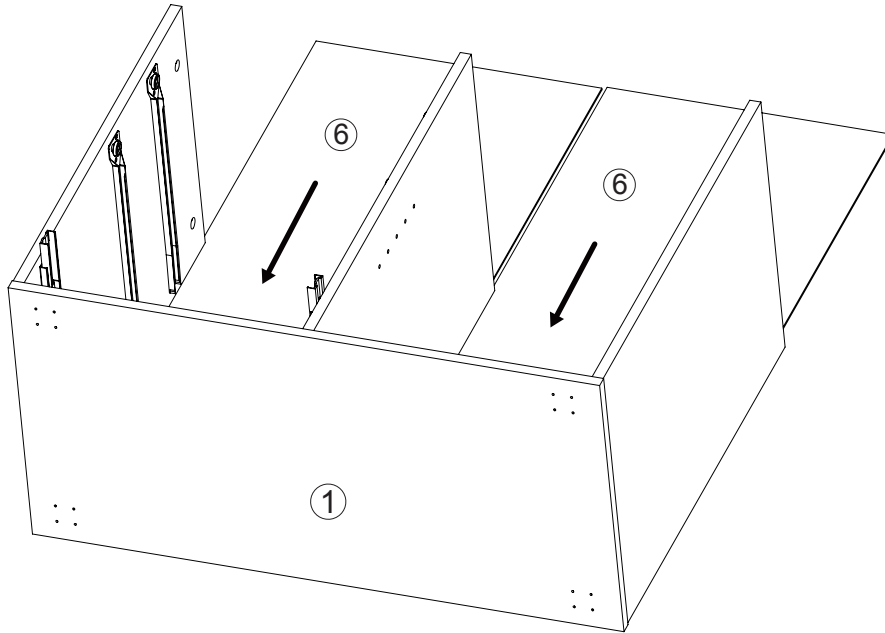

**23.**

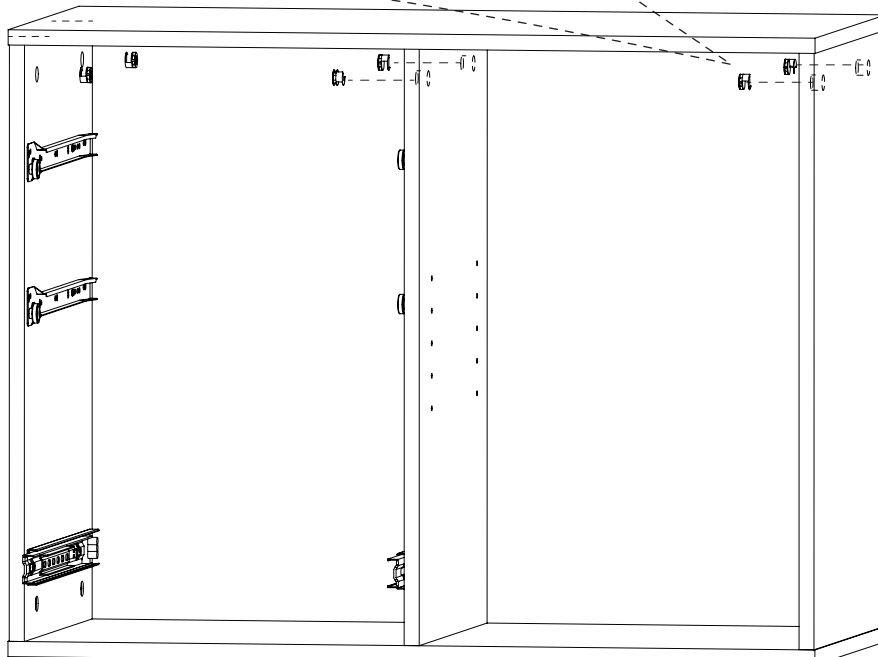
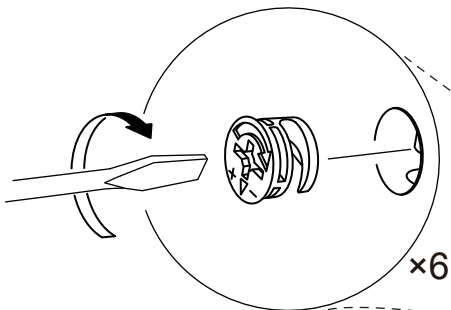
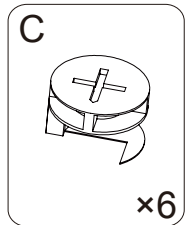
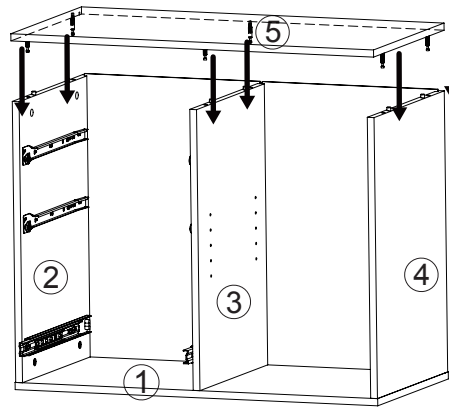
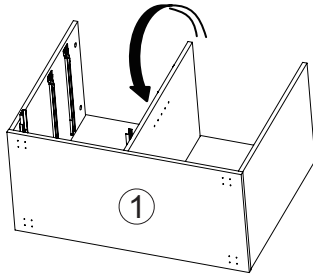

**24.**

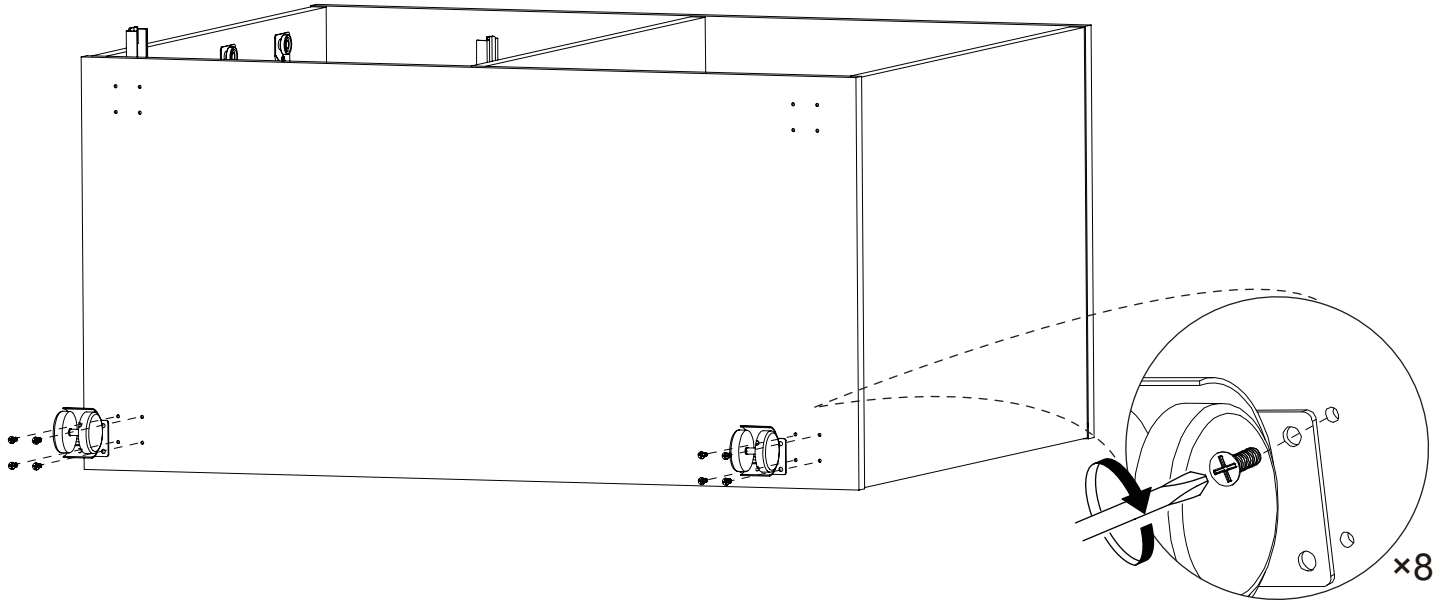
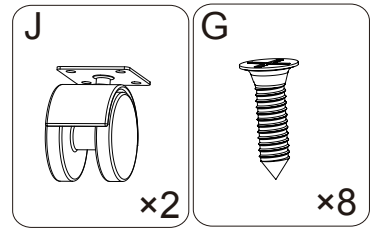
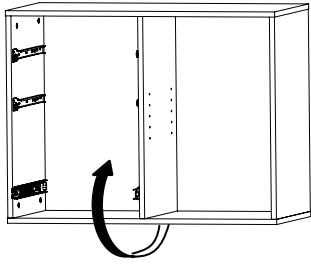

**25.**

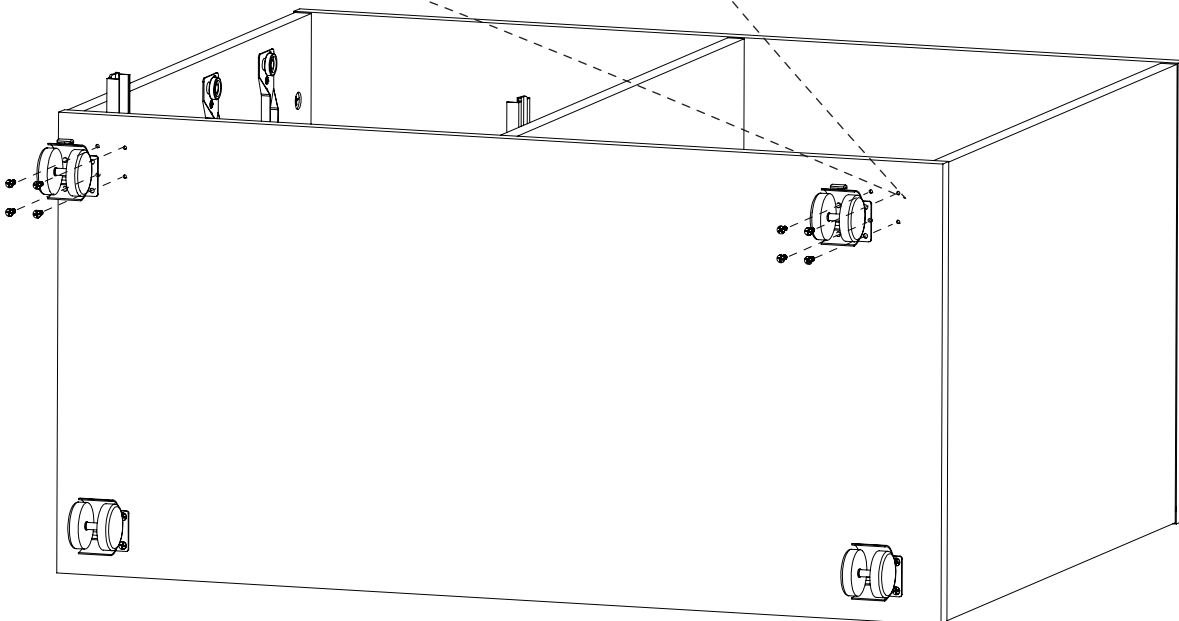
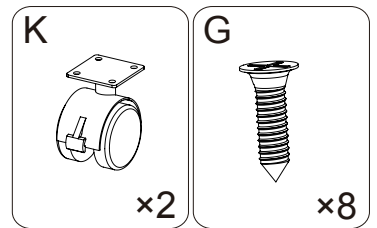
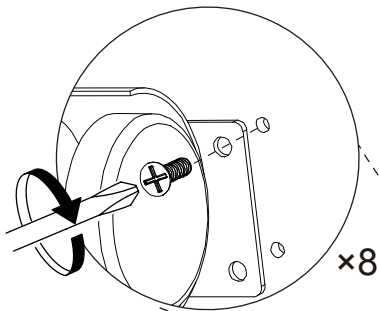

26.

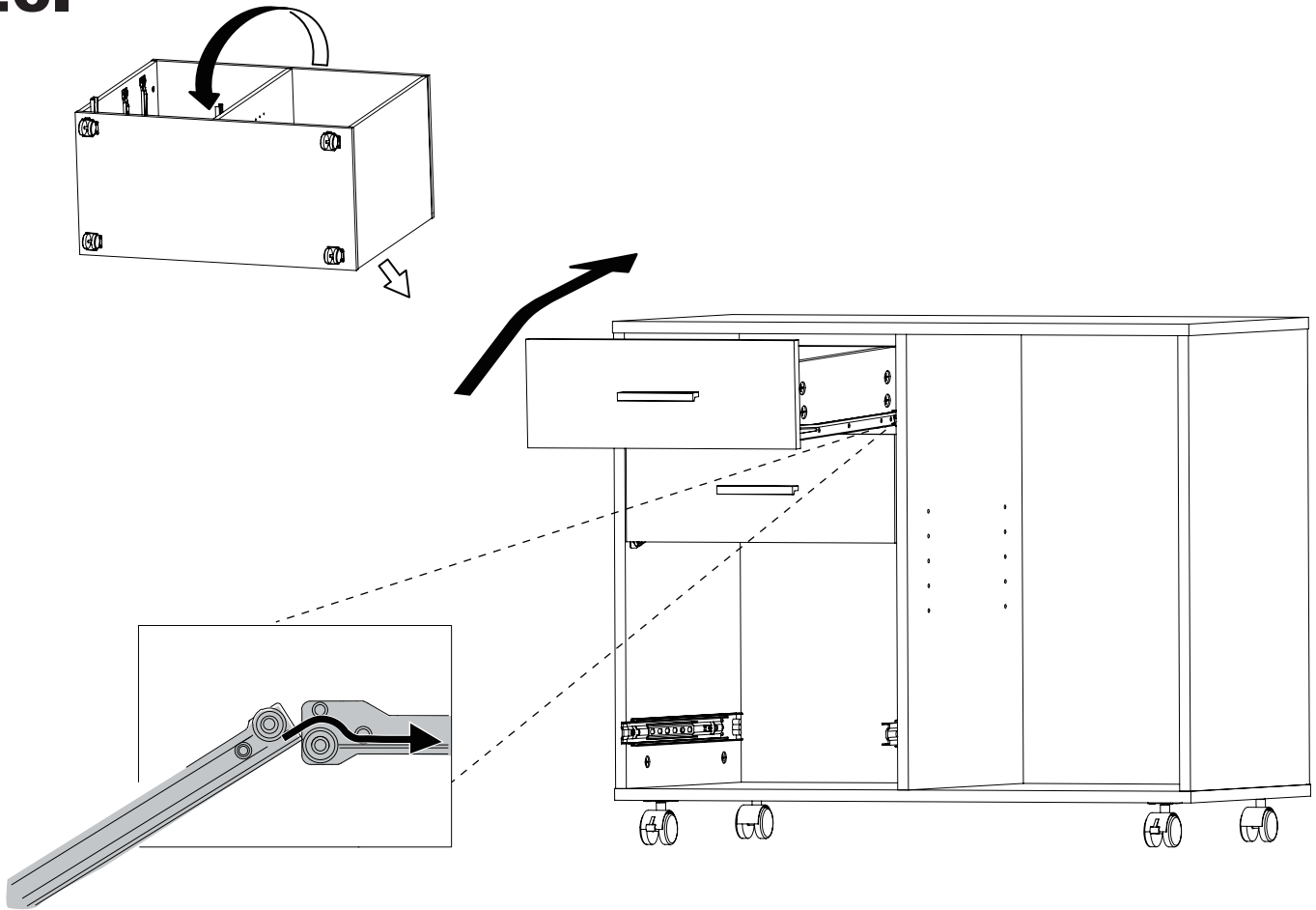

27.

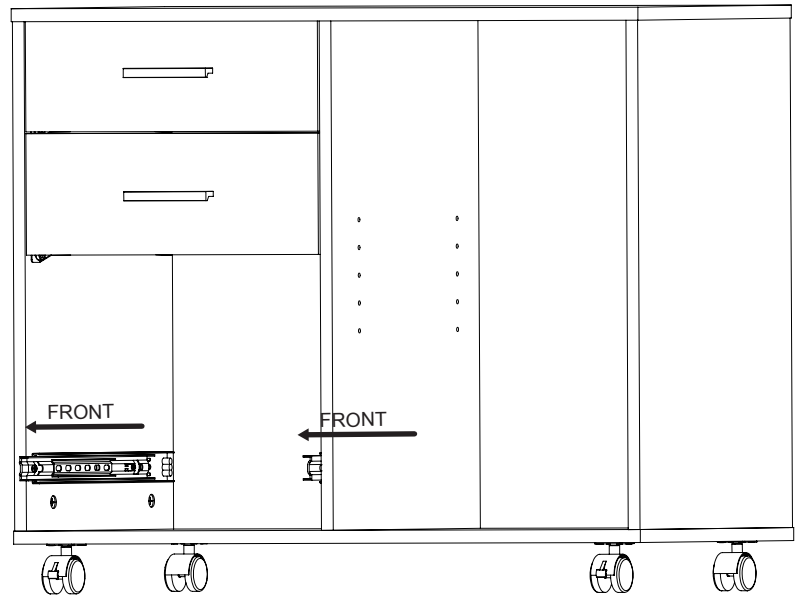
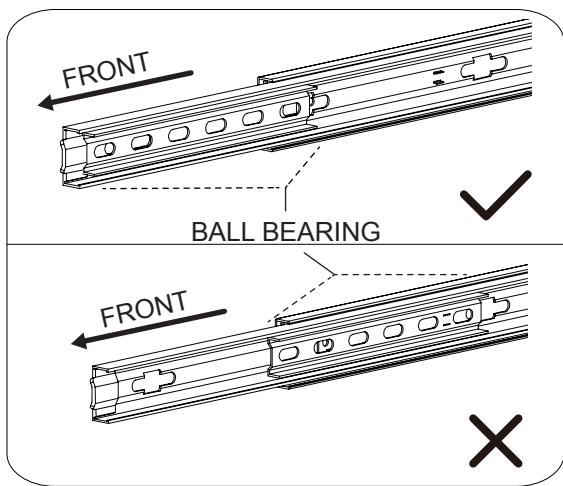

**REMARK:**

Simply push the ball bearing cart all the way to the end of the slide(in both sides), and align the slide runners on the drawer with the unit and push it carefully inside until it stops.

**NOTE:**

If the drawer does not go in smoothly please take it out and repeat the step.

**28.**

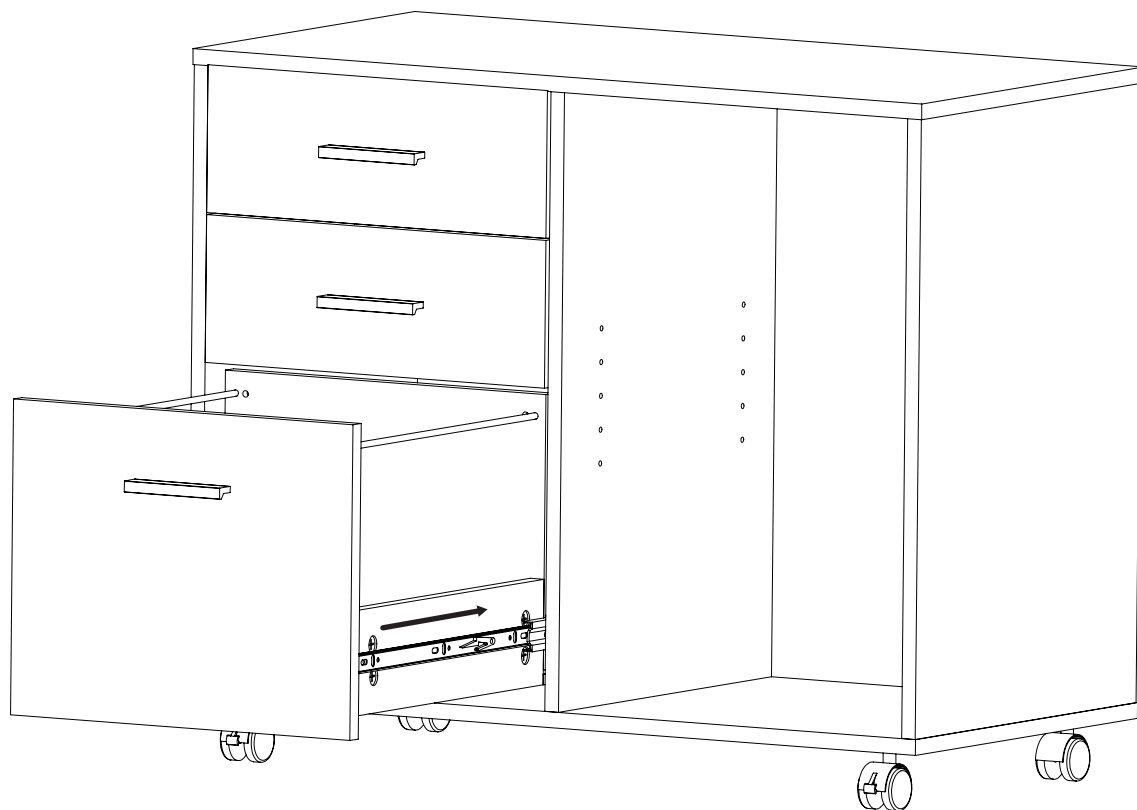

**29.**

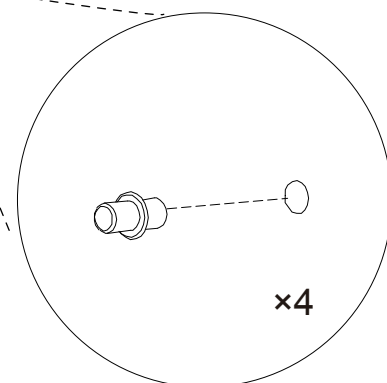
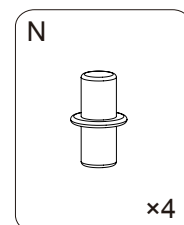
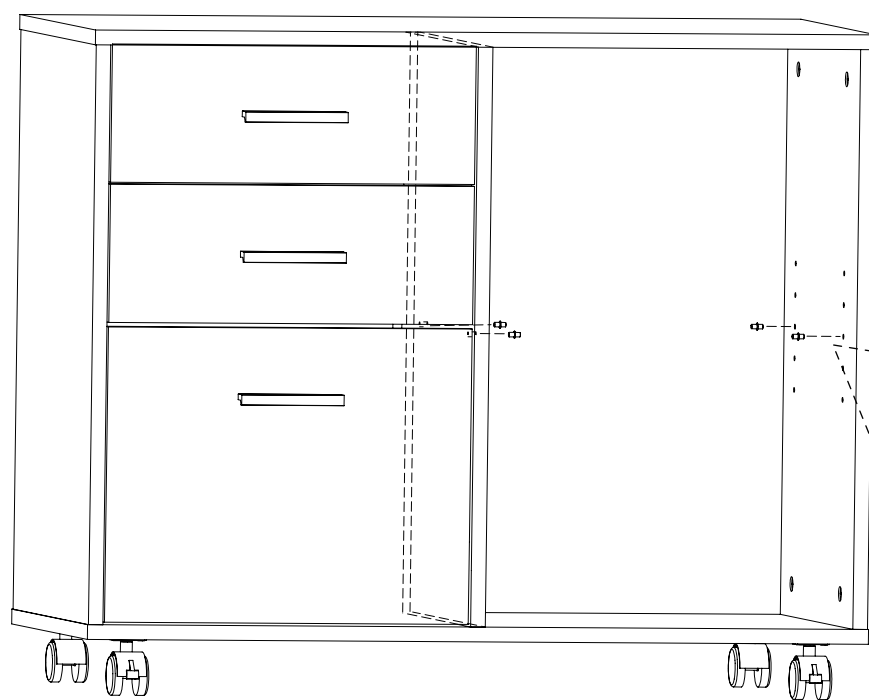

**30.**

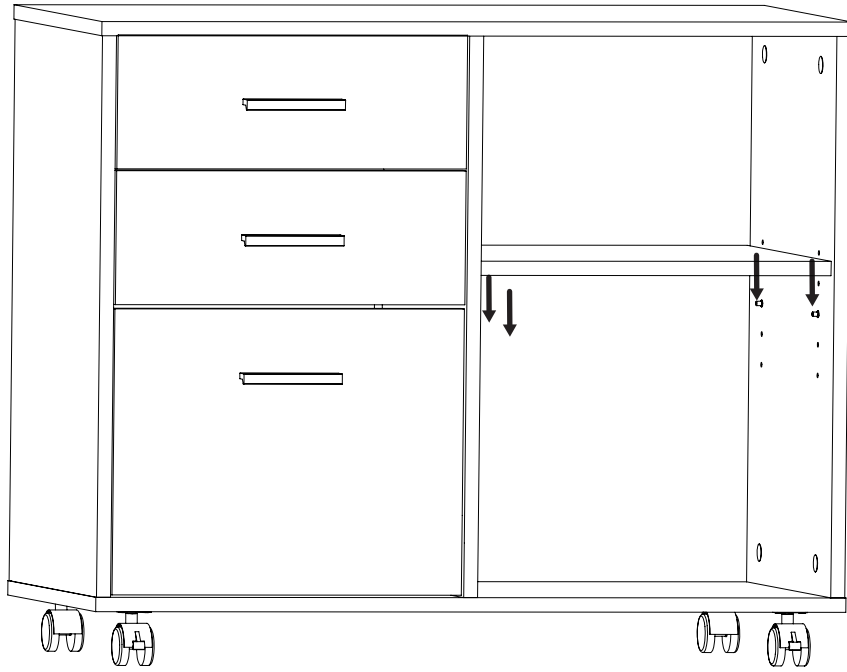

**31.**

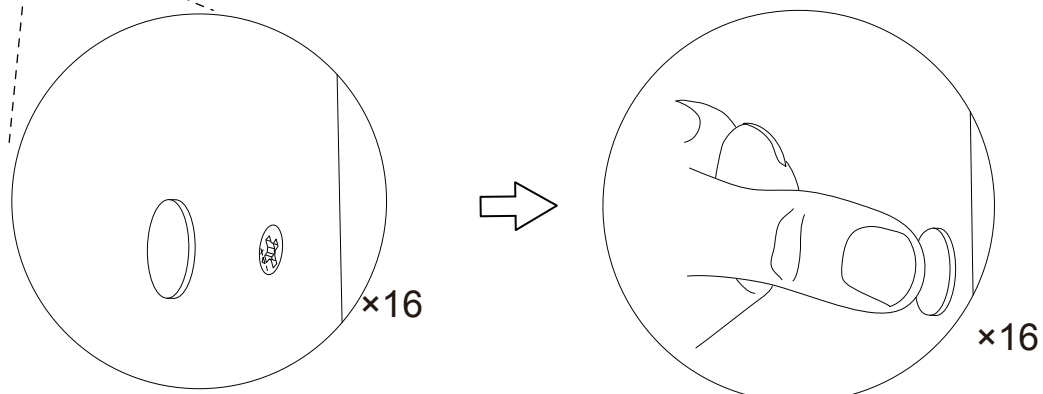
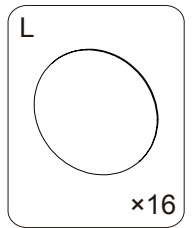
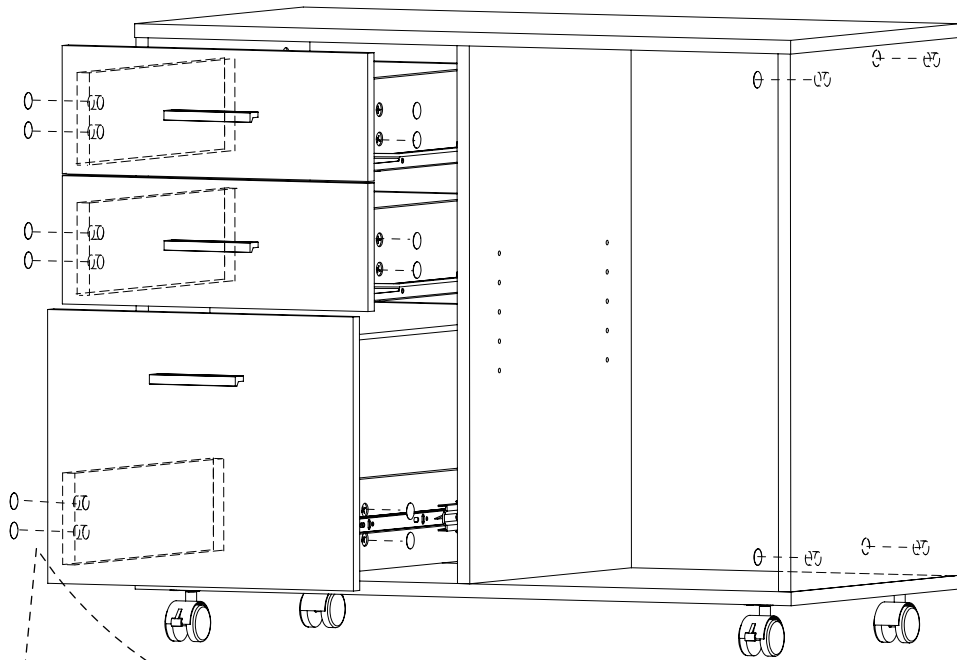

32.

