

ASSEMBLY INSTRUCTIONS

2622K

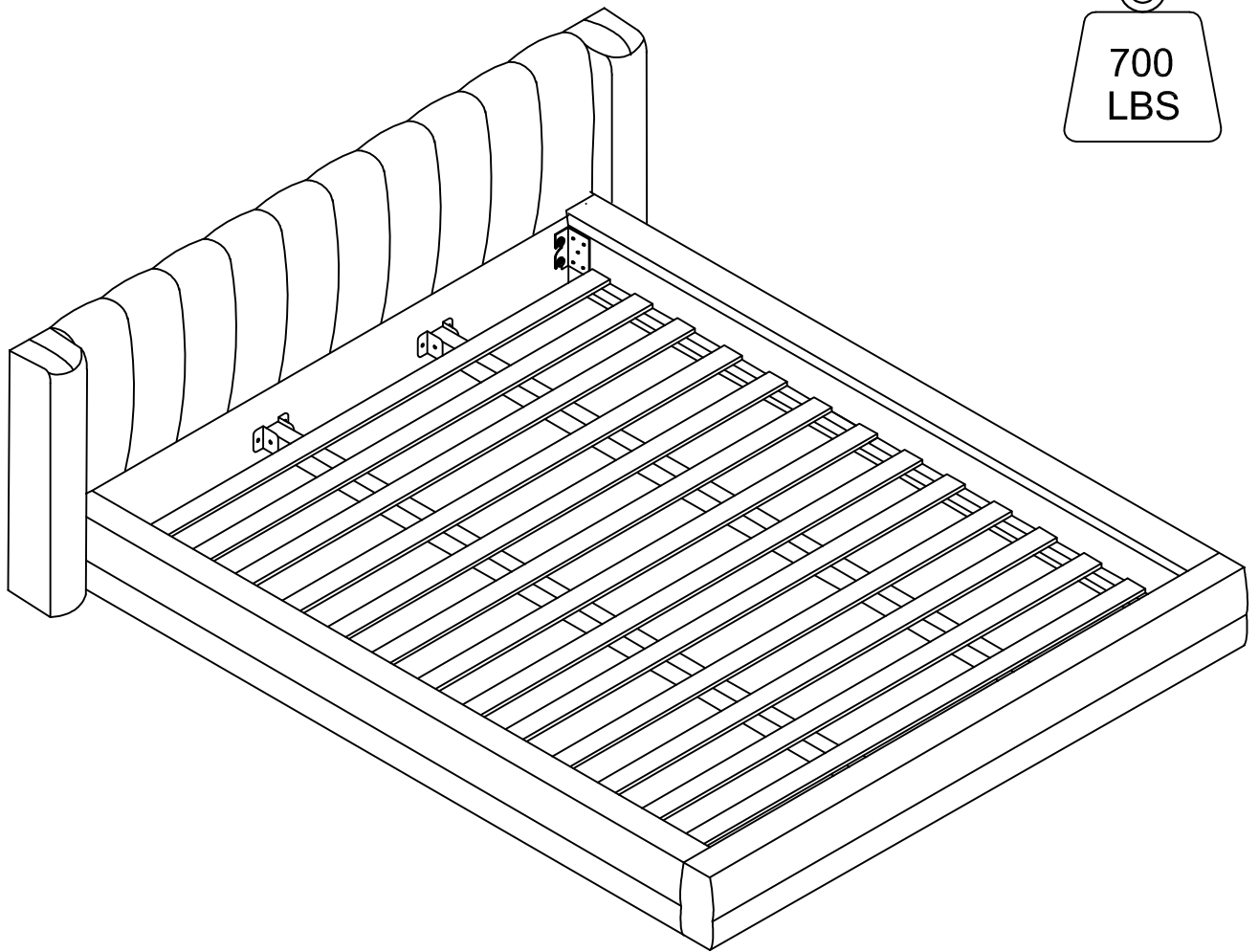

Install all screws according to the instructions, and then tighten them completely.

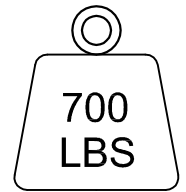

NOTE: The slats are stored at the bottom of Section A

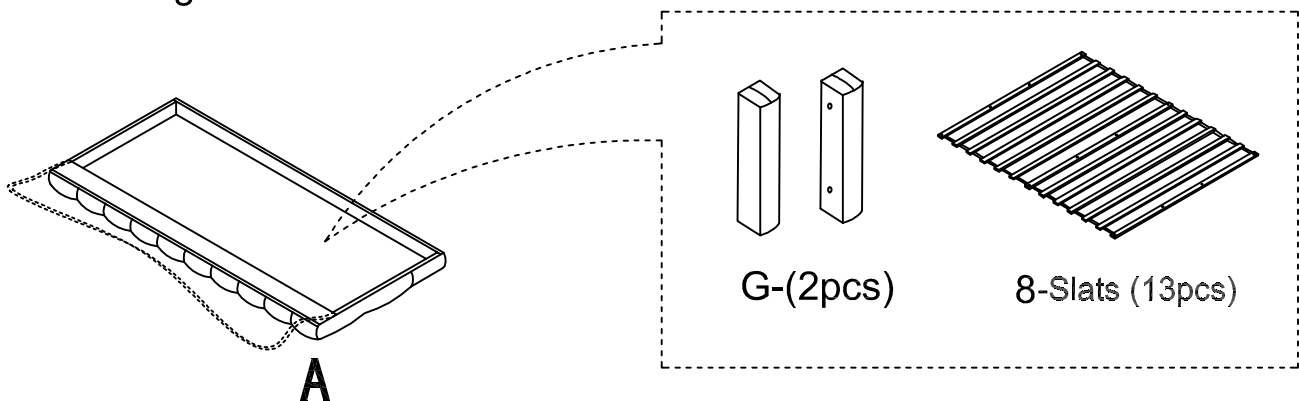
STEP: Packing Details



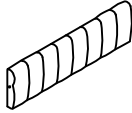
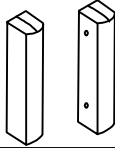
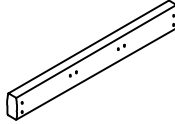

PACKING DETAILS:TOTAL 2 BOXES





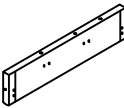
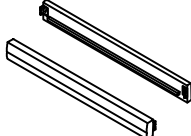



BOX- 1/2

2622K-A	
PART	
	1-Headboard(1pc)
	3 -Headboard Ear (2pcs)
	4 -Footboard (1pc)
	5 -(4pcs)

BOX-2/2

2622K-B	
PART	
	2-Headboard(1pc)
	6-Side Rails (2pcs)
	7-Center Support Bar (2pcs)
	8-Slats (13pcs)

BOX- 1/2

2622K-A	
PART	
	m8*30 Bolt A - (8pcs)
	m6*25 Bolt B-(8pcs)
	m8 Spring Washer C-(15pcs)
	m8*19 Flat Washer D-(15pcs)
	m6*16 Flat Washer E - (8pcs)
	m8 Allen Key F - (1pc)
	m6 Allen Key G - (1pc)
	m4*25 Screw H -(12pcs)
	m8*45 Bolt I-(7pcs)

ASSEMBLY INSTRUCTIONS

STEP 1

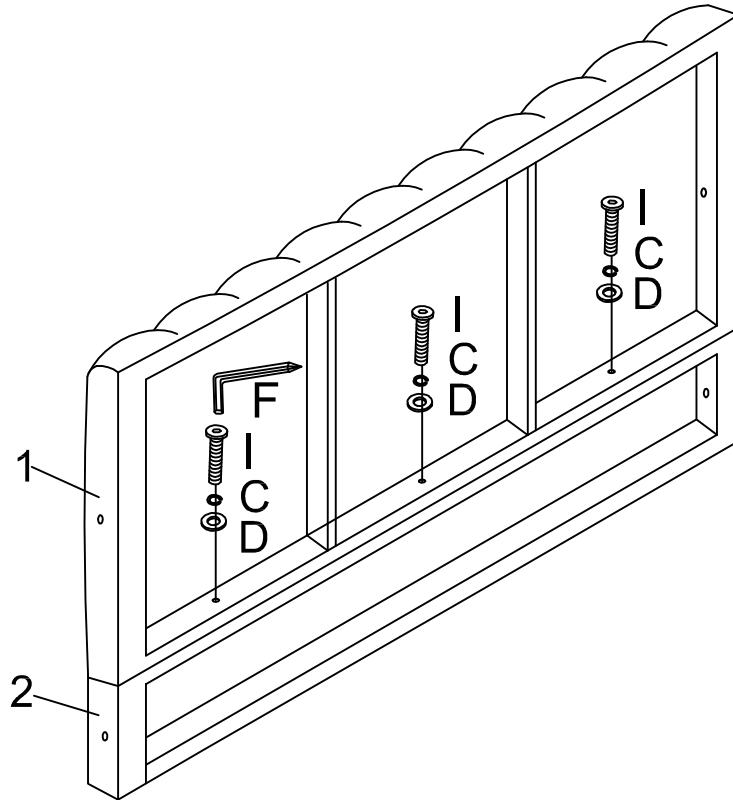

STEP 2

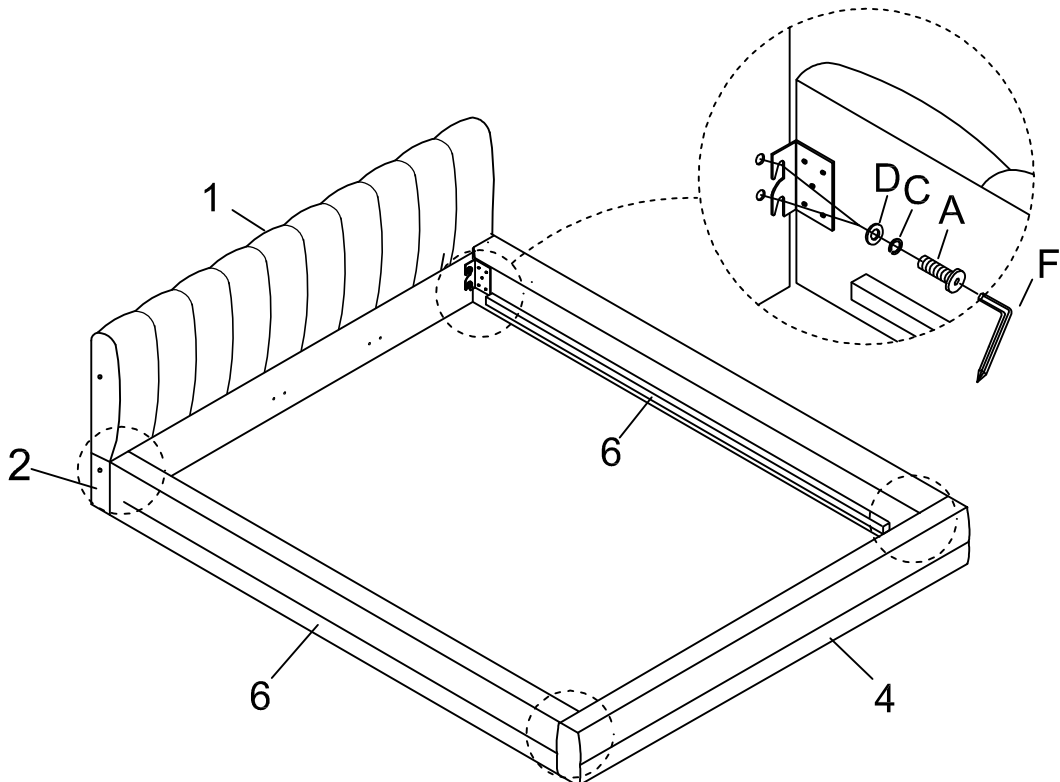

ASSEMBLY INSTRUCTIONS

STEP 3

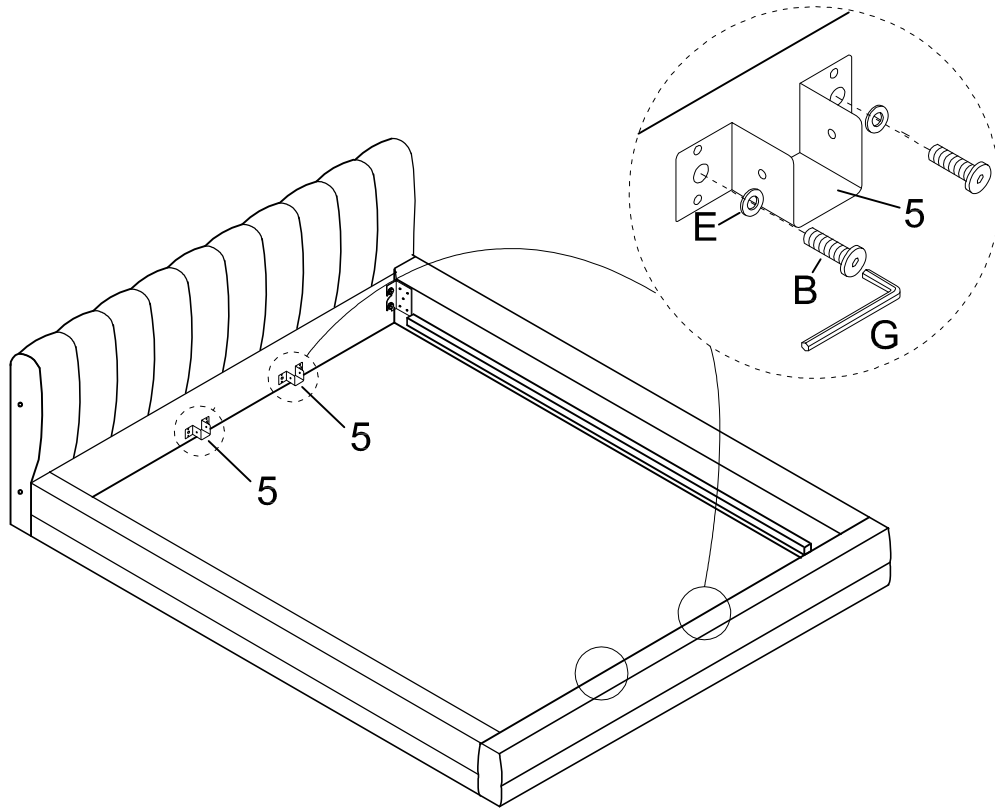

STEP 4

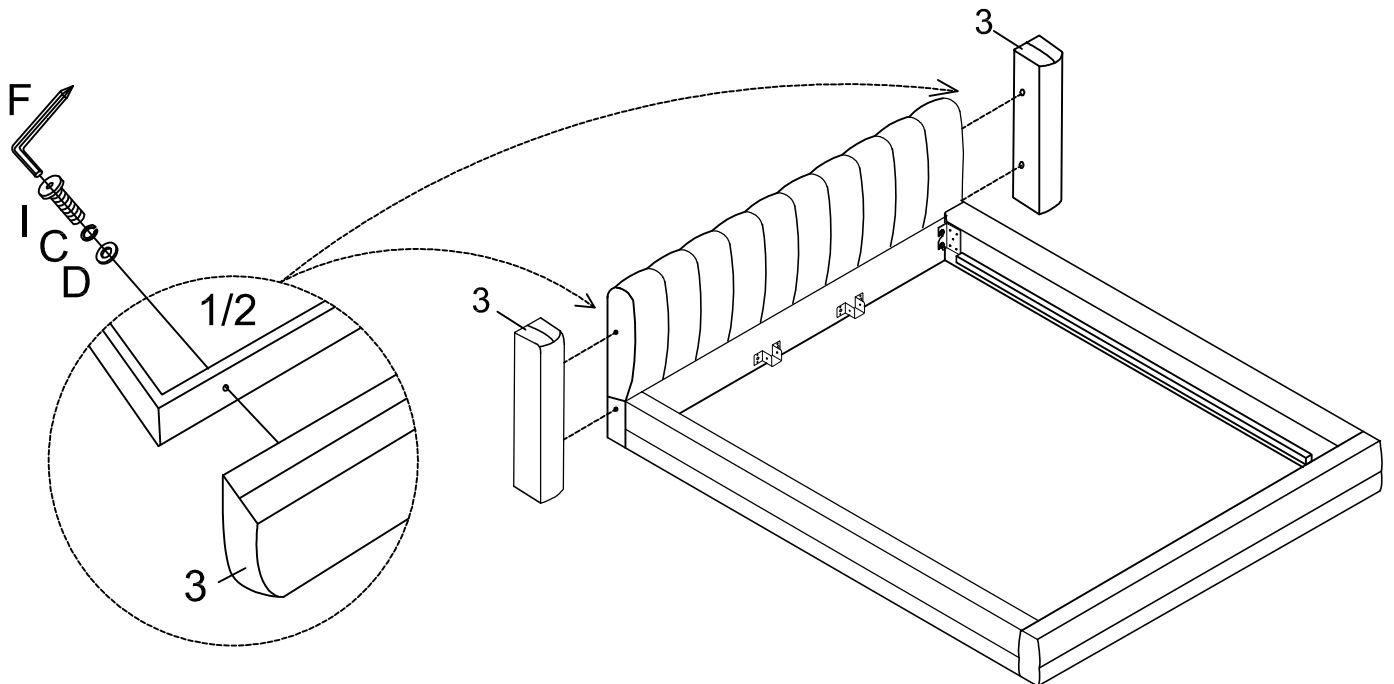

ASSEMBLY INSTRUCTIONS

STEP 5

F-slats (13pcs)

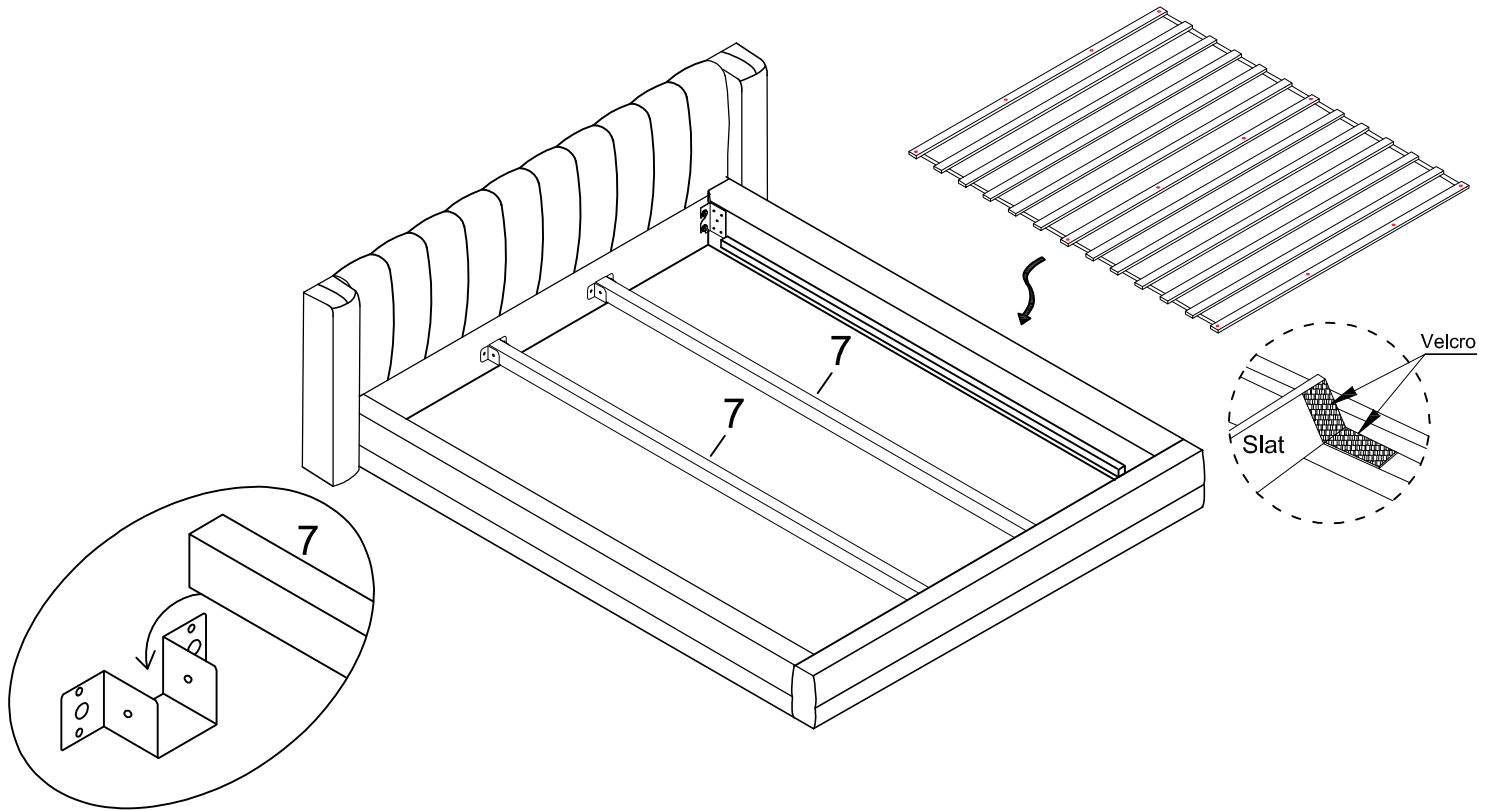

STEP 6

