

## ASSEMBLY INSTRUCTION

Montageanleitung  
Instructions De Montage  
Istruzioni Per L'assemblaggio  
Instrucciones De Montaje  
組立説明書  
安装说明书



## HELPFUL HINTS

### BEFORE YOU START

- Inspect product packaging to ensure the appearance is good.
- Read the assembly instruction carefully and follow it step by step.
- To avoid any scratching, putting a soft blanket on the floor is suggested.
- Identify, sort and count all the parts with tags.
- Find out installation position according to the drawing and install it in correct steps.

### OTHER

- People needed for assembly: 1-2.
- Estimated assembly time: 1.5-2h.

### CAUTION

- Be cautious when using a power drill or power screwdriver.
- Please be aware to slow down and stop when screw is nearly tight.
- Do Not use any harsh chemicals or abrasive cleaners for this item.
- Push, pull or drag this item carefully.

## ASTUCES UTILES

### AVANT DE COMMENCER

- Inspectez l'emballage du produit pour vous assurer que l'apparence est bonne.
- Lisez attentivement les instructions de montage et suivez-les étape par étape.
- Pour éviter toute rayure, posez une couverture douce sur le sol est suggéré.
- Identifiez, triez et comptez toutes les pièces avec des étiquettes.
- Trouver la position d'installation selon le dessin et l'installer dans les étapes correctes.

### AUTRE

- Personnes nécessaires pour l'assemblage : 1-2.
- Temps de montage estimé : 1.5-2 h.

### AVERTIR

- Soyez prudent lorsque vous utilisez une perceuse électrique ou un tournevis électrique.
- Veuillez être conscient de ralentir et d'arrêter lorsque la vis est presque serrée.
- N'utilisez pas de produits chimiques corrosifs ou de nettoyants abrasifs pour cet article.
- Poussez, tirez ou tirez cet article avec précaution.

## CONSEJOS ÚTILES

### ANTES DE EMPEZAR

- Inspeccione el paquete del producto para asegurarse de que la apariencia es buena.
- Lea atentamente las instrucciones de montaje y sígalas paso a paso.
- Para evitar rayas, se sugiere poner una manta suave en el suelo.
- Identifique, clasifique y enumere todas las piezas con etiquetas.
- Averigüe la posición de instalación según el dibujo e instálela en los pasos correctos.

### OTROS

- Personas necesarias para el montaje: 1-2.
- Tiempo de montaje estimado: 1.5-2 h.

### PRECAUCIÓN

- Tenga cuidado al utilizar un taladro eléctrico o un destornillador eléctrico.
- Tenga en cuenta que debe hacerlo más despacio y detenerse cuando el tornillo esté casi apretado.
- No utilice productos químicos agresivos ni limpiadores abrasivos para este artículo.
- Empuje, tire o arrastre este elemento con cuidado.

## SUGGERIMENTI UTILI

### PRIMA DI INIZIARE

- Controllare la confezione del prodotto per assicurarsi che sia in buono stato.
- Leggere con attenzione le istruzioni per l'assemblaggio e seguirle passo dopo passo.
- Per evitare graffi al pavimento, suggeriamo di stendervi una coperta morbida.
- Identificare, suddividere e contare tutte le parti con etichetta.
- Trovare la posizione adatta per il montaggio in base al disegno e montare lo scaffale seguendo correttamente i vari passaggi.

### ALTRO

- Persone necessarie per l'assemblaggio: 1-2.
- Tempo di assemblaggio stimato: 1.5-2 ora.

### ATTENZIONE

- Prestare molta attenzione quando si utilizza un trapano elettrico o un cacciavite elettrico.
- Rallentare con accortezza e fermarsi quando una vite è già sufficientemente serrata.
- Non utilizzare prodotti chimici aggressivi o detergenti abrasivi su questo articolo.
- Spingere, tirare o trascinare questo articolo con cautela.

## NÜTZLICHE HINWEISE

### ⚠️ BEVOR SIE BEGINNEN

- Überprüfen Sie die Produktverpackung auf Schäden.
- Lesen Sie sich die Montageanleitung sorgfältig durch und befolgen Sie sie Schritt für Schritt.
- Um etwaiges Zerkratzen zu vermeiden, wird das Auslegen einer weichen Decke auf dem Boden empfohlen.
- Identifizieren, sortieren und zählen Sie alle Teile mit Tags nach.
- Identifizieren Sie die Montageposition gemäß der Zeichnung und bauen Sie das Regal den richtigen Schritten entsprechend auf.



### SONSTIGES

- Für den Zusammenbau erforderliche Anzahl an Menschen: 1-2.
- Ungefähre Montagedauer: 1.5-2 h.

### ⚠️ VORSICHT

- Seien Sie bei der Verwendung einer Bohrmaschine oder eines Akkuschraubers vorsichtig.
- Bitte vergessen Sie nicht darauf, langsamer zu werden und zu stoppen, sobald die Schraube fast festgezogen ist.
- Verwenden Sie keinerlei aggressive Chemikalien oder scheuernden Reinigungsmittel für dieses Produkt.
- Schieben oder ziehen Sie dieses Produkt vorsichtig.

## 温馨提示

### ⚠️ 安装前注意事项

- 检查产品包装, 确保外观良好。
- 仔细阅读安装说明, 按步骤操作。
- 为了避免刮伤, 建议在地板上放一条柔软的毯子。
- 标识、分类和清点所有部件。
- 根据图形找到安装孔位, 按正确步骤安装。



### 其他:

- 组装所需人员: 1-2人。
- 预计组装时间: 1.5-2小时。

### ⚠️ 注意:

- 小心使用电钻或电动螺丝刀。
- 当螺丝快要拧紧时, 请注意减速。
- 不要使用任何刺激性化学物质或清洗剂。
- 当推、拉或拖动产品时, 注意小心谨慎, 防止损坏。

## 役に立つヒント

### ⚠️ 組立の場所を確保し、順番通りに組み立てる

- 組立場所 (充分広くて平たい場 所) を確保してください。
- 床や壁、商品を傷つけないように、商品の下に厚めの布や段ボールなどを敷いてください。
- 組立の順番を守らないと、組立できなくなったり、商品を傷つけたりします。



### その他

- 組み立てに必要な人: 1-2。
- 組立時間: 約1.5-2時間。

### ⚠️ 部品を確認する

- ネジ類などの部品番号、形状を説明書の部品一覧で確認してください。
- 部品をなくさないように纏めて置いてください。
- 部品を取り出すときに使う分だけ取り出してください。

# DETAILS

DETAILS  
DÉTAILS/POINTS DE MONTAGE  
NOTE PARTICOLARI

DETALLES  
組み立てのポイント  
詳細情報

This user manual is applicable for Queen】 frame series products.  
Ce manuel d'utilisation est applicable aux produits avec les cadres Queen】.  
Diese Installationsanleitung gilt für Produkte der Bettrahmenserie Queen】.  
Questo manuale utente è valido per i prodotti di serie con telaio Queen】  
Este manual de usuario es aplicable a los productos de las series de marcos Queen】.  
本取付説明書は Queen】 ベッドフレームシリーズ製品に適用します。  
此安装说明书适用于【Queen】系列产品。

UNIT: INCH/CM/厘米

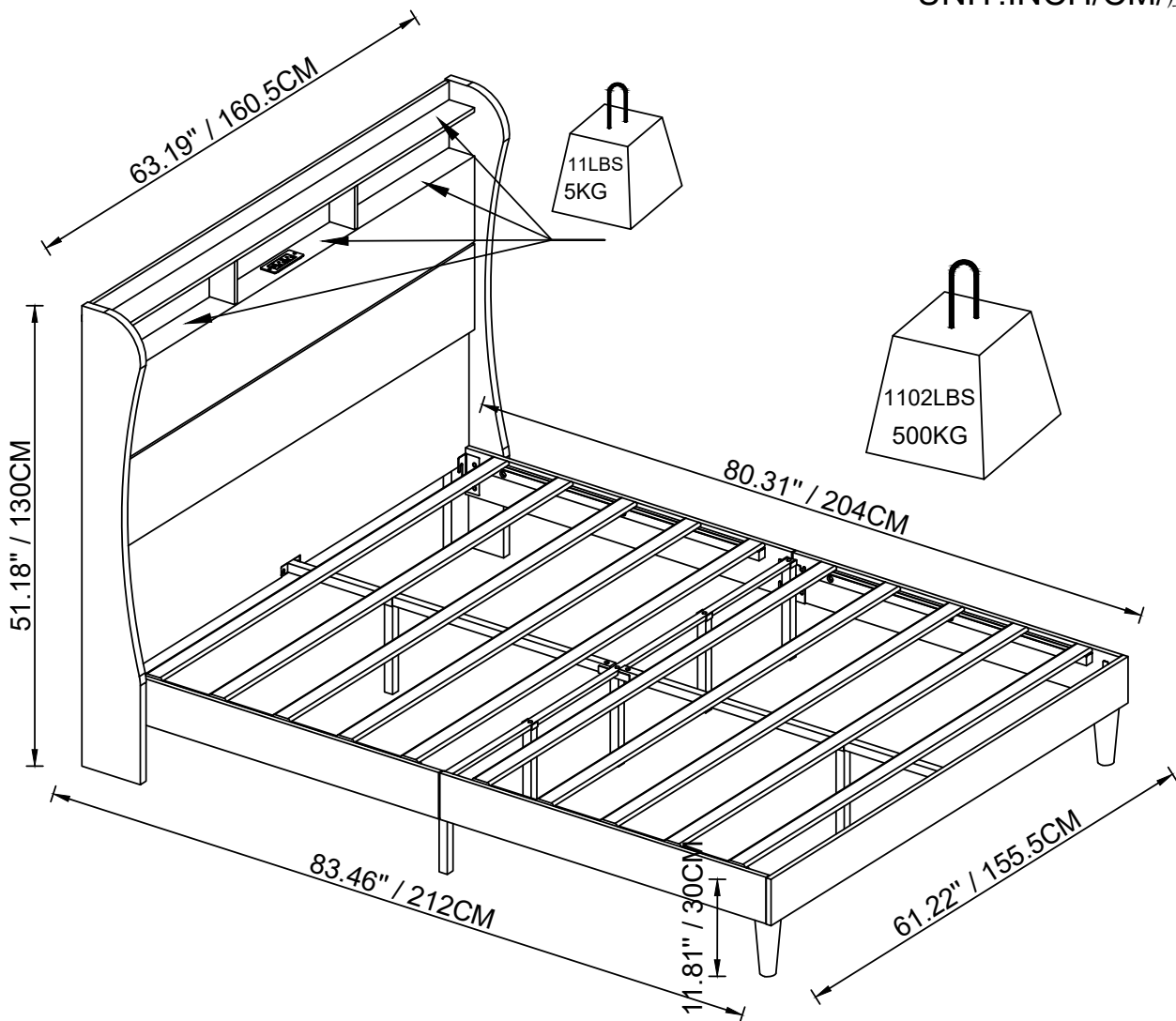

- The size of the mattress that matches this bedstead: 61.22"(155.5CM)x80.31"(204CM)
- La taille du matelas à laquelle correspond ce châlit: 61.22"(155.5CM)x80.31"(204CM)
- Matratzengröße, die zu diesem Bettgestell passt: 61.22"(155.5CM)x80.31"(204CM)
- Misura materasso compatibili con questo giroletto: 61.22"(155.5CM)x80.31"(204CM)
- Tamaño del colchón para este marco de cama: 61.22"(155.5CM)x80.31"(204CM)
- このベッドフレームにマッチングするマットレスのサイズ: 61.22"(155.5CM)x80.31"(204CM)
- 此床架匹配的床垫尺寸: 61.22"(155.5CM)x80.31"(204CM)

# DETAILS

DETAILS  
DÉTAILS/POINTS DE MONTAGE  
NOTE PARTICOLARI

DETALLES  
組み立てのポイント  
詳細情報

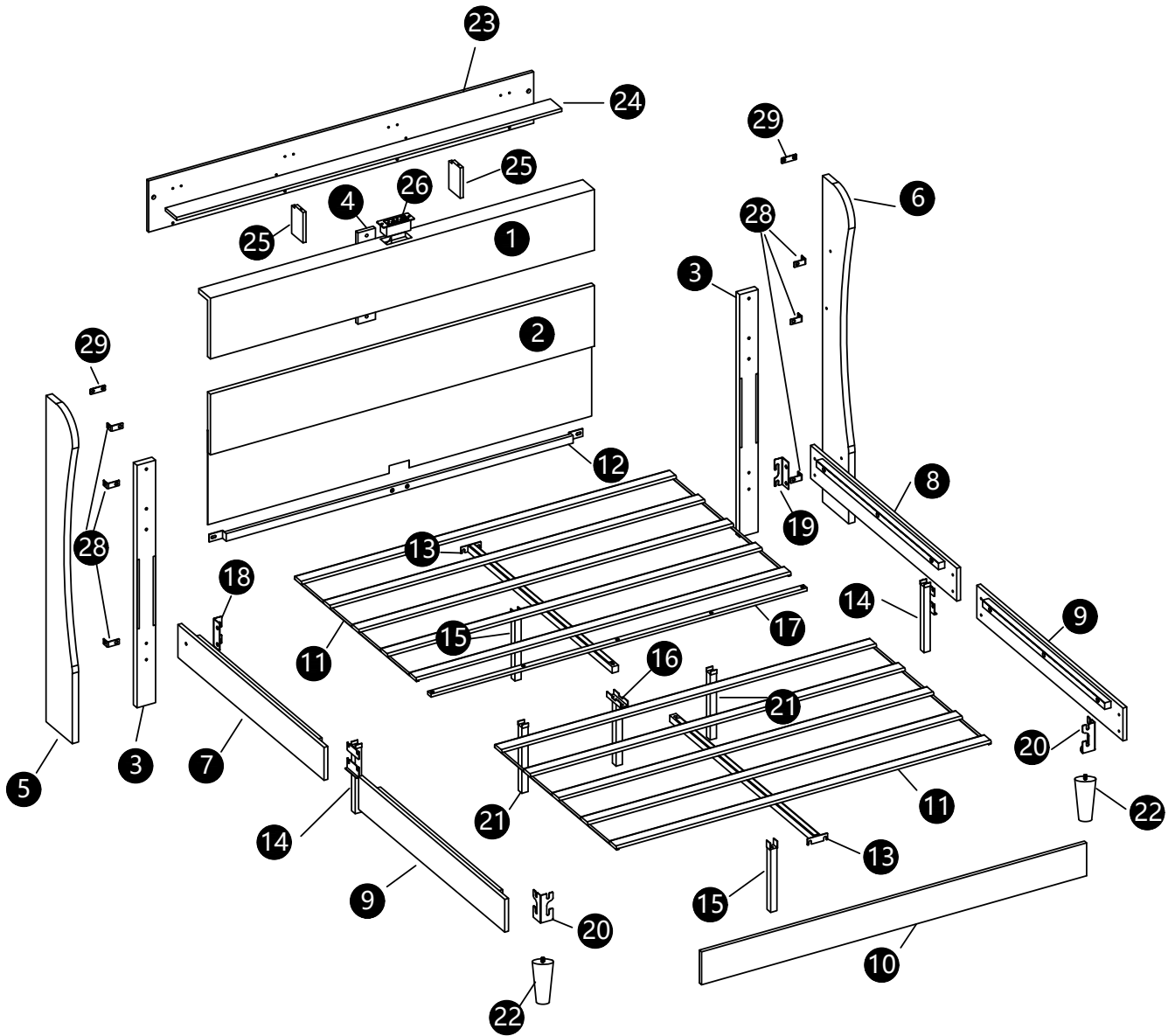

# PART LIST

STÜCKLISTE  
LISTE DES PIÈCES  
ELENCO DEI PEZZI

LISTA DE PIEZAS  
部品の確認  
部件清單

1

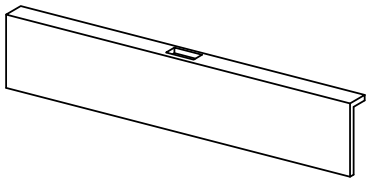

X1

2

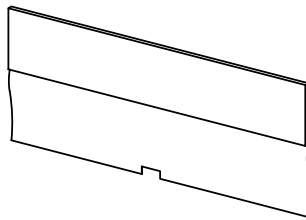

X1

3



X2

4

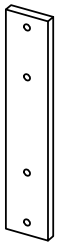

X1

5



X1

6



X1

7

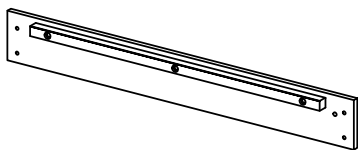

X1

8

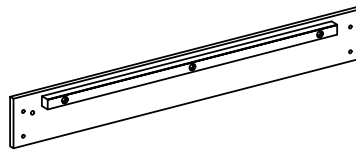

X1

9

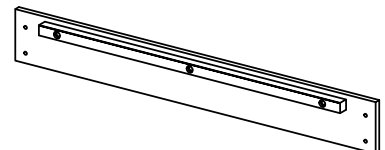

X2

10

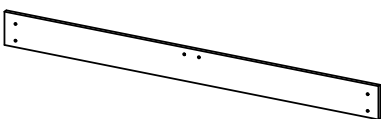

X1

11

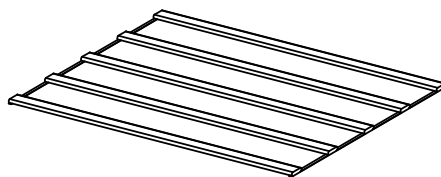

X2

12

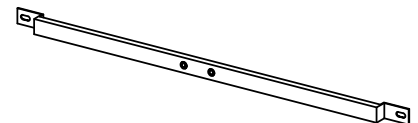

X1

13

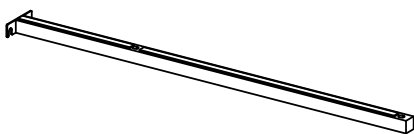

X2

14



X2

15

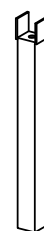

X2

# PART LIST

STÜCKLISTE  
LISTE DES PIÈCES  
ELENCO DEI PEZZI

LISTA DE PIEZAS  
部品の確認  
部件清單

16

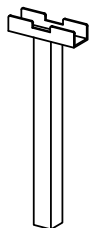

X1

17

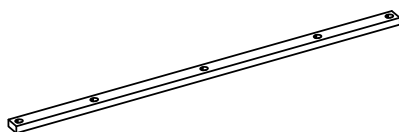

X1

18

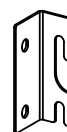

X1

19



X1

20



X2

21



X2

22



X2

23

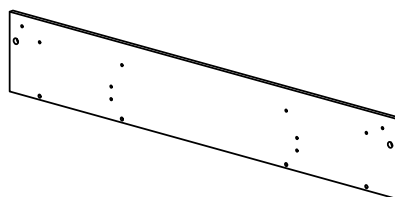

X1

24

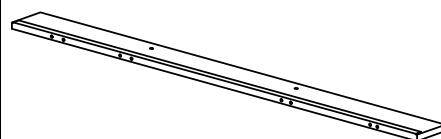

X1

25



X2

26

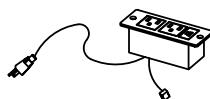

X1

27

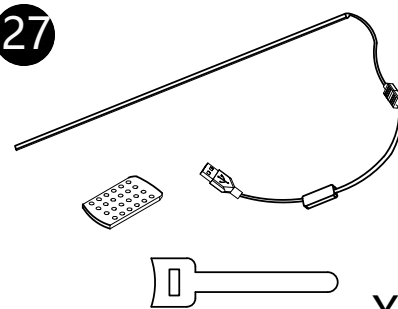

X1

28

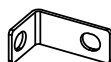

X6

29







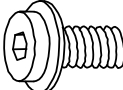
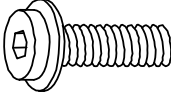
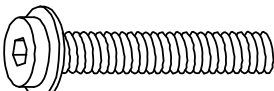
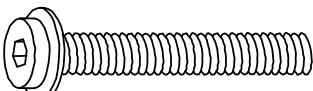
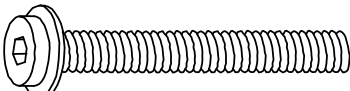
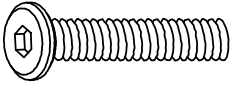
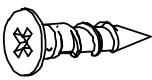

X2

# ACCESSORY LIST

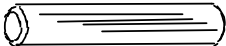
LISTE DES ACCESSOIRES  
ZUBEHÖRLISTE  
ELENCO DEGLI ACCESSORI

LISTA DE ACCESORIOS  
付属品部品の確認  
配件清单

<b>A</b>	M8x10mm	2+1	
<b>B</b>	M8x15mm	42+2	
<b>C</b>	M8x30mm	4+1	
<b>D</b>	M8x35mm	11+1	
<b>E</b>	M8x40mm	6+1	
<b>F</b>	M6x25mm	4+1	
<b>G</b>	M4x15mm	2+1	
<b>H</b>	M6x40mm	8+1	
<b>I</b>	φ6x30mm	6+1	
<b>J</b>	D5	1	
<b>K</b>	D4	1	
<b>L</b>		1	

※Remote control battery installation procedure

※Étapes d'installation de la batterie à télécommande

※ Schritte zur Installation der Batterie der Fernbedienung

※Passaggi di installazione della batteria del telecomando

※Pasos de instalación de la batería de control remoto

※リモコンの電池取り付け手順

※遥控器电池安装步骤

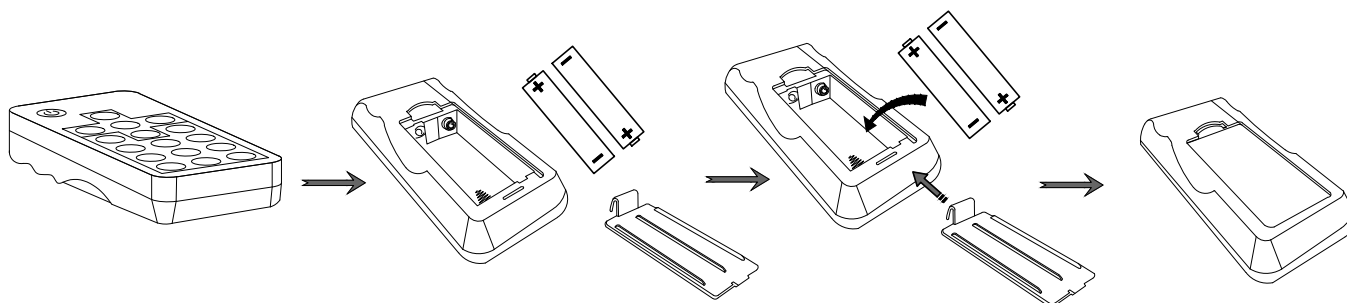

1. The battery compartment is located on the back end of the remote control.
2. Press and slide the battery door open.
3. Insert 2 AAA batteries, checking that the + and - sides of the battery match inside the battery compartment.
4. Replace the battery compartment door.
5. Batteries are not included in the package due to safety transportation.

**Note:**

- A. Do not mix old and new batteries together in the remote.
- B. Do not mix alkaline, standard(carbon-zinc), or rechargeable (NiCad, NiMh, etc.) batteries together.

- 
- 1.Le compartiment de la batterie est situé à l'arrière de la télécommande.
  - 2.Appuyez et faites glisser la porte de la batterie pour l'ouvrir.
  3. Insérez 2 piles AAA et vérifiez si le côté + et le côté - de la batterie correspondent. Dans le compartiment de la batterie.
  4. Remplacez le couvercle de la batterie.
  5. En raison du transport sûr, la batterie n'est pas incluse dans l'emballage.

**Remarque :**

- A. Ne mélangez pas les anciennes et les nouvelles batteries dans la télécommande.
- B. Ne mélangez pas les piles alcalines, standard (zinc carbone) ou rechargeables (NiCad, NiMh, etc.).

- 
1. Das Batteriefach befindet sich am hinteren Ende der Fernbedienung.
  2. Drücken und schieben Sie die Batterietür, um sie zu öffnen.
  3. Setzen Sie 2 AAA-Batterien ein und überprüfen Sie, ob die +-Seite und --Seite der Batterie übereinstimmen, Im Batteriefach.
  4. Ersetzen Sie die Batterietür.
  5. Aufgrund des sicheren Transports ist die Batterie nicht im Paket enthalten.

**Hinweis:**

- A. Mischen Sie alte und neue Batterien nicht in der Fernbedienung.
- B. Mischen Sie keine Alkali-, Standard- (Kohlenstoff-Zink) oder wiederaufladbaren (NiCad, NiMh usw.) Batterien zusammen.

1. Il vano batteria si trova nella parte posteriore del telecomando.
2. Premere e far scorrere lo sportello della batteria per aprirlo.
3. Inserire 2 batterie AAA e verificare se il lato + e il lato - della batteria corrispondono.  
Nel vano batteria.
4. Sostituire lo sportello della batteria.
5. A causa del trasporto sicuro, la batteria non è inclusa nel pacchetto.

**Nota:**

- A. Non mescolare insieme batterie vecchie e nuove nel telecomando.
  - B. Non mescolare insieme batterie alcaline, standard (carbon zinco) o ricaricabili (NiCad, NiMh, ecc.).
- 

1. El compartimento de la batería se encuentra en la parte trasera del mando a distancia.
2. Presione y deslice la puerta de la batería para abrirla.
3. Inserte 2 pilas AAA y compruebe si el lado + y el lado - de la batería coinciden.  
En el compartimento de la batería.
4. Reemplace la puerta de la batería.
5. Debido a la seguridad del transporte, la batería no está incluida en el paquete.

**Nota:**

- A. No mezcle las baterías viejas y nuevas en el mando a distancia.
  - B. No mezcle baterías alcalinas, estándar (zinc de carbono) o recargables (NiCad, NiMh, etc.).
- 

1. 電池室はリモコンの後ろ側にあります。
2. 電池ドアを押してスライドさせて開けます。
3. 2本のAAA電池を、電池室内の+と-が一致するように挿入します。
4. 電池室のドアを元に戻します。
5. 安全輸送のため、電池をパッケージに入れしないでください。

**注意:**

- A. 古い電池と新しい電池を一緒に使用しないでください。
  - B. アルカリ電池、標準（炭酸亜鉛）電池、充電式（ニッカド、ニッケル水素など）電池を混ぜて使用しないでください。
- 

1. 电池舱位于遥控器的后端。
2. 按下并滑动打开电池舱门。
3. 插入两节AAA电池，检查电池的正极和负极是否与电池内部隔间匹配。
4. 合上电池舱门。
5. 出于运输安全考虑，包装中不包括电池。

**注意:**

- A. 不要在遥控器中将新旧电池混在一起。
- B. 不要将碱性、标准（碳锌）或可充电（镍镉、镍氢等）电池混合在一起。

1

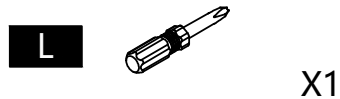
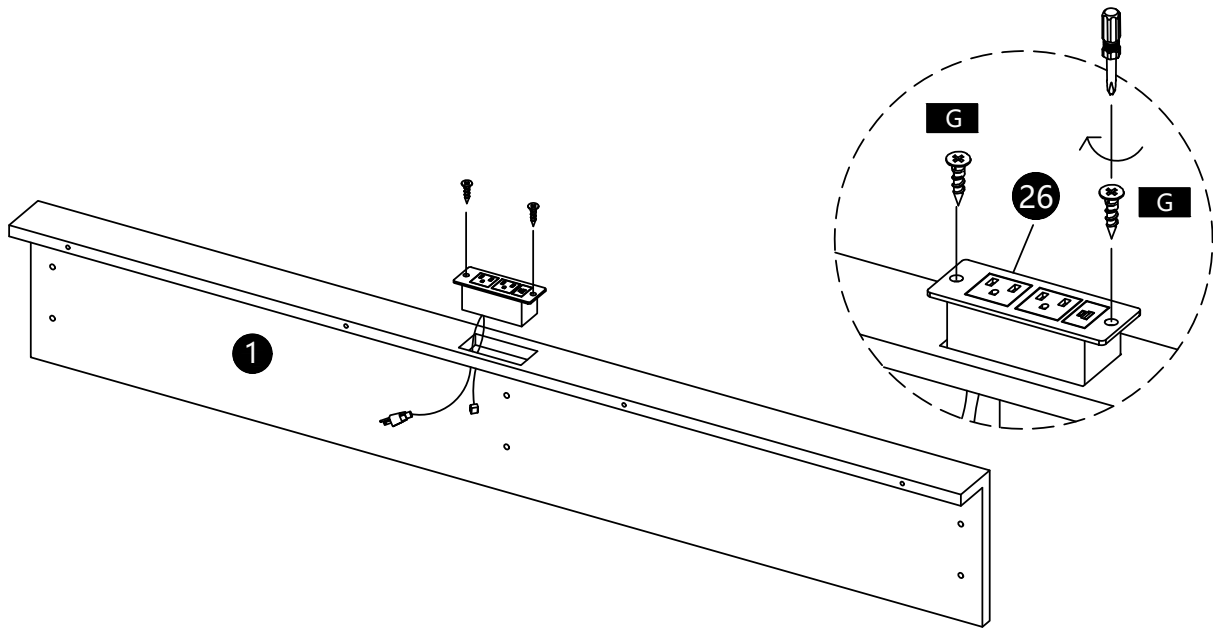

2

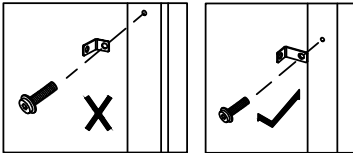
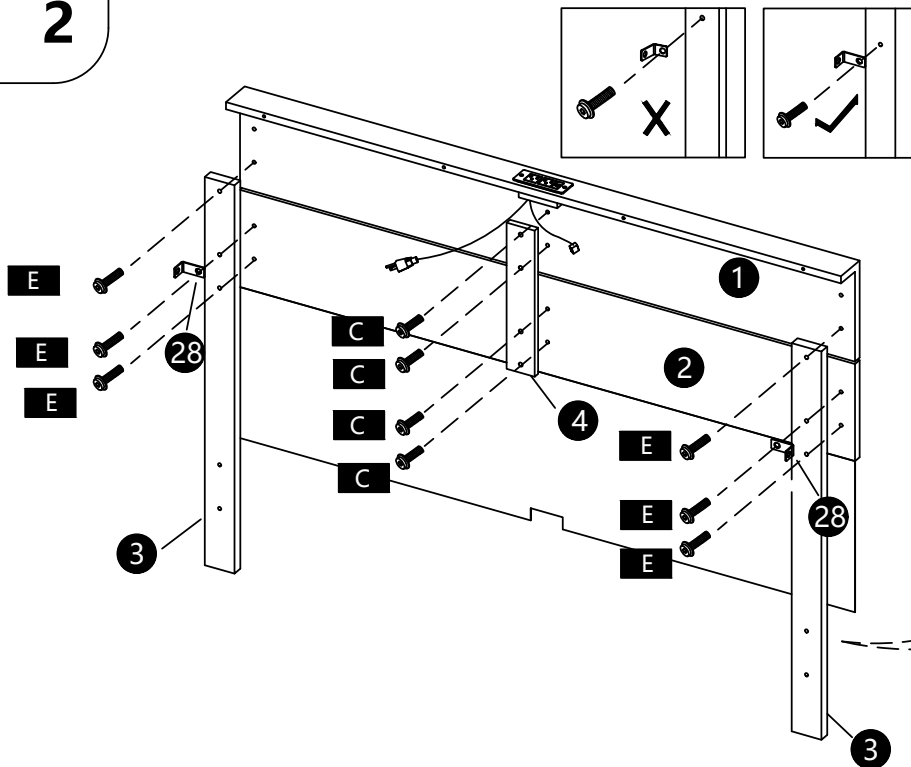

Two persons are needed.  
Deux personnes sont nécessaires.  
Zwei Personen sind erforderlich.  
Sono necessarie due persone.  
Se necesitan dos personas.  
必ず2人で作業してください。  
※需要男1个人协助。

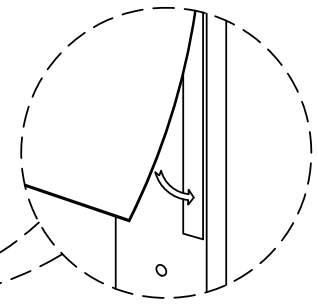
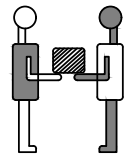

The flannel is adhered to the bed foot with Velcro.

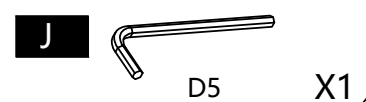
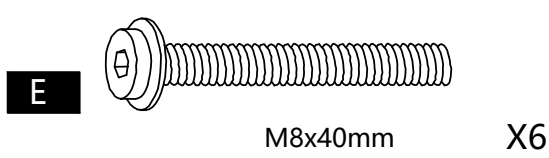
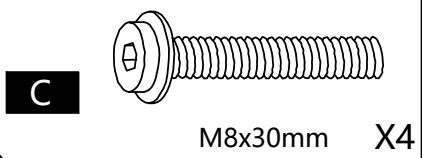

3

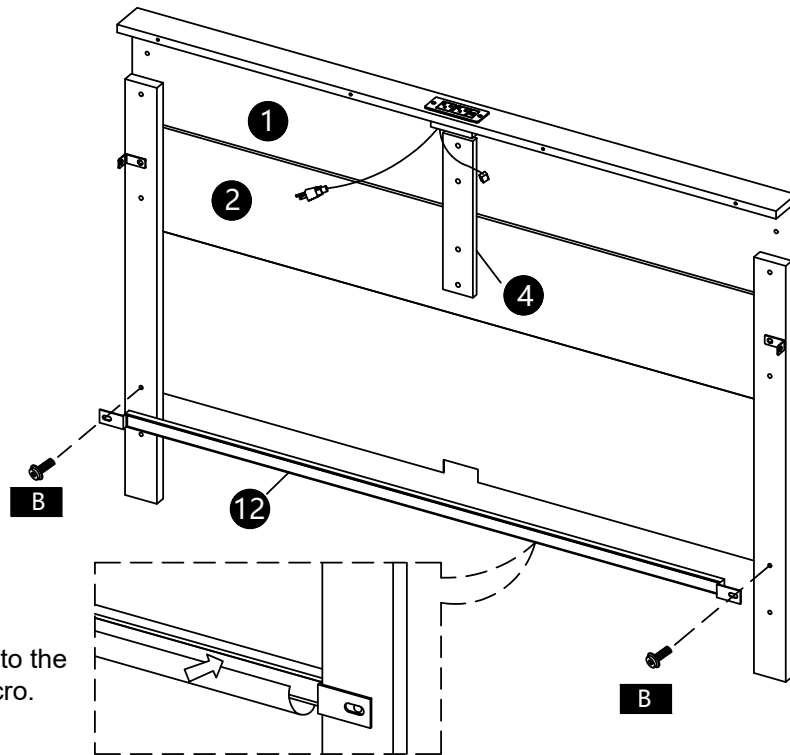

The flannel is adhered to the horizontal rod with Velcro.

**B**

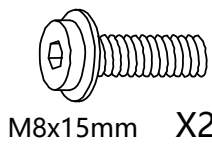

M8x15mm X2

**K**



D5 X1

4

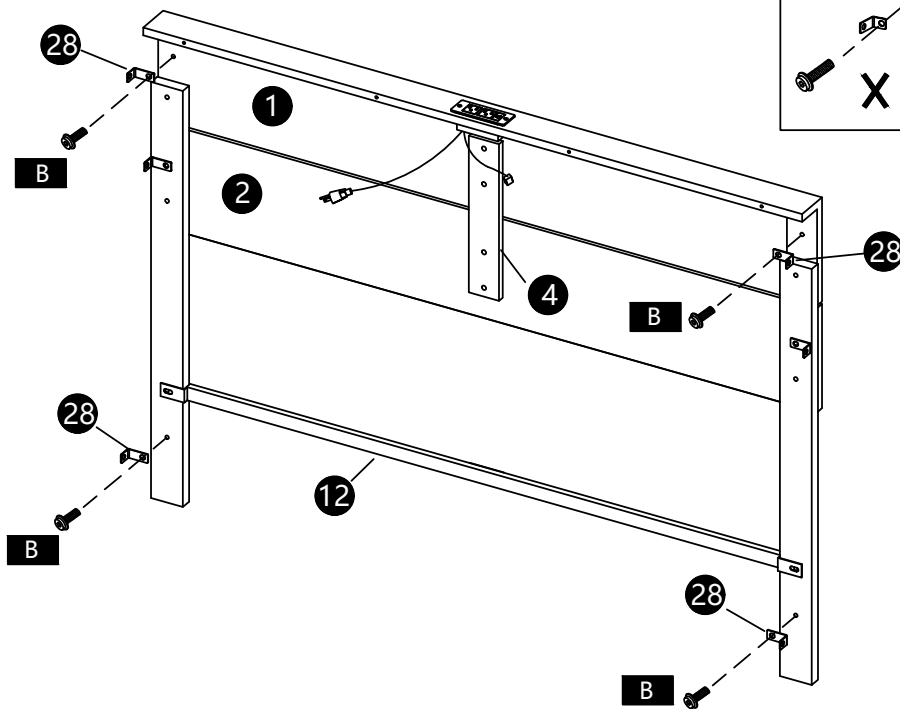

**B**

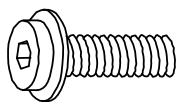

M8x15mm X4

**J**



D5 X1

5

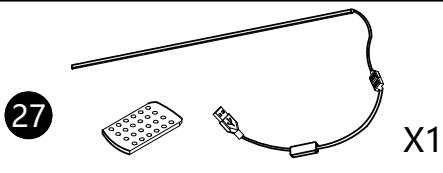
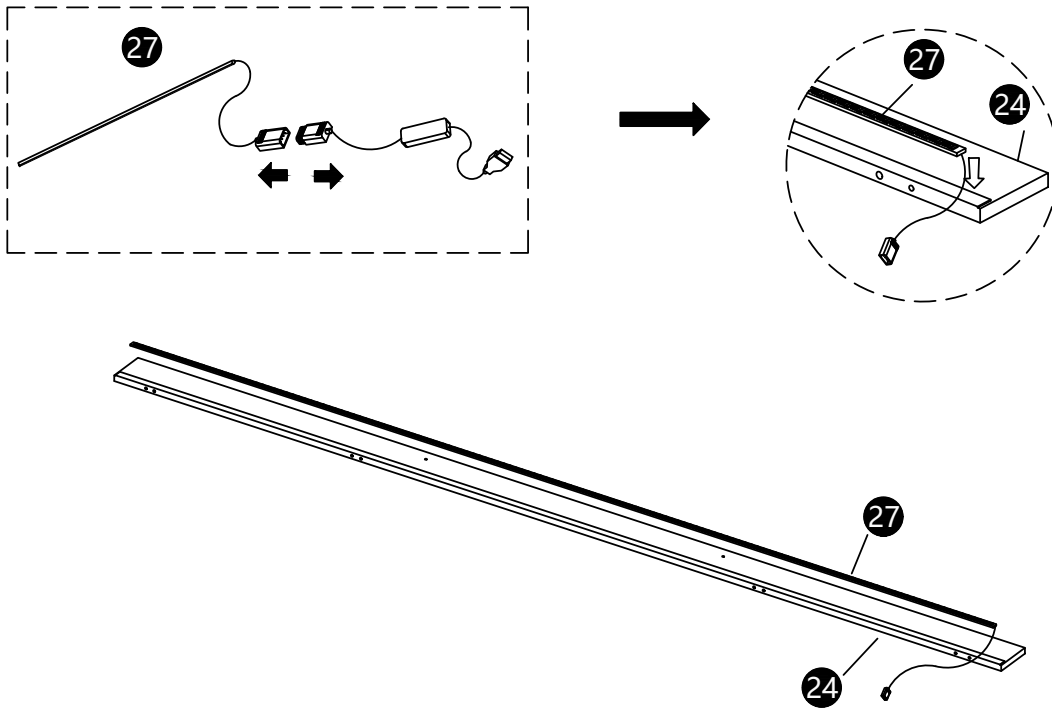

6

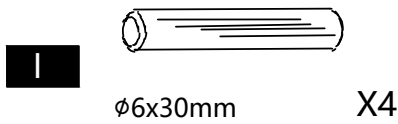
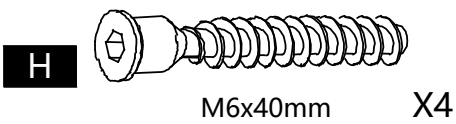
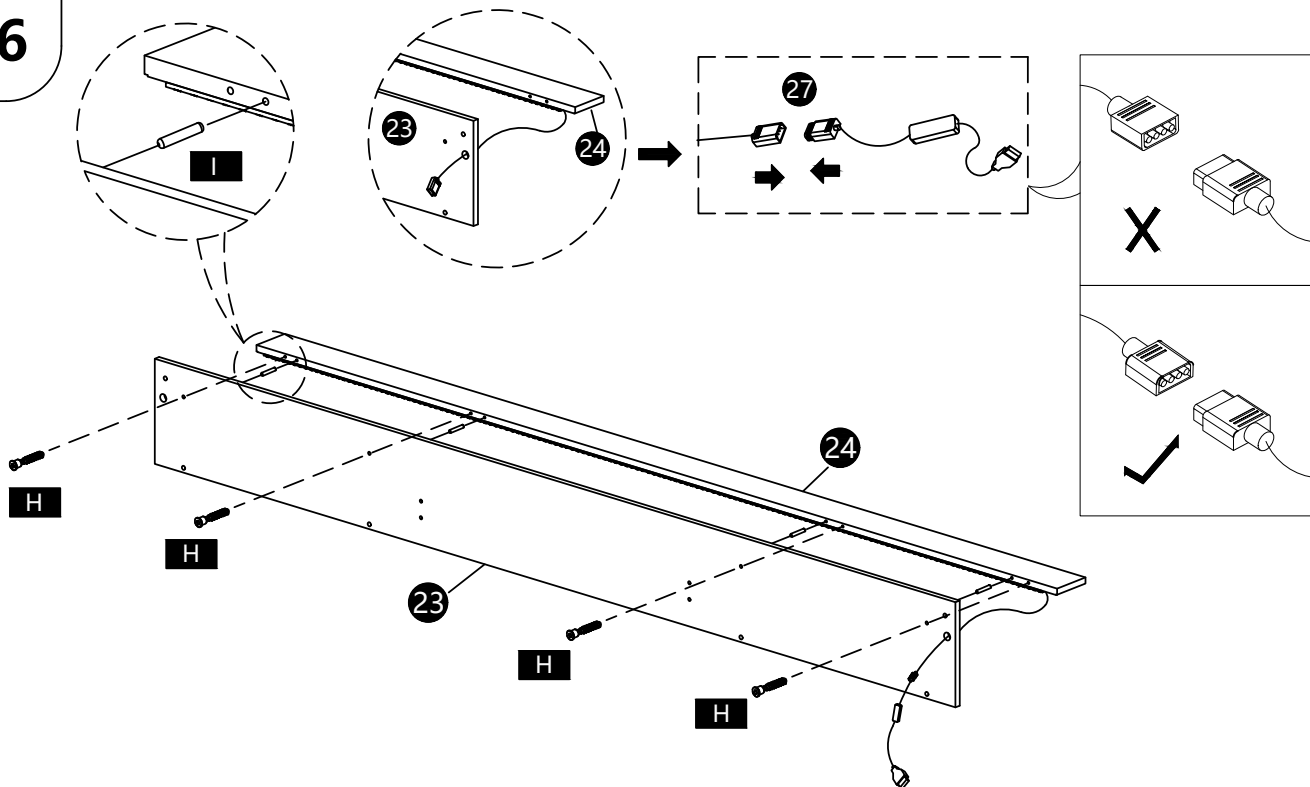

7

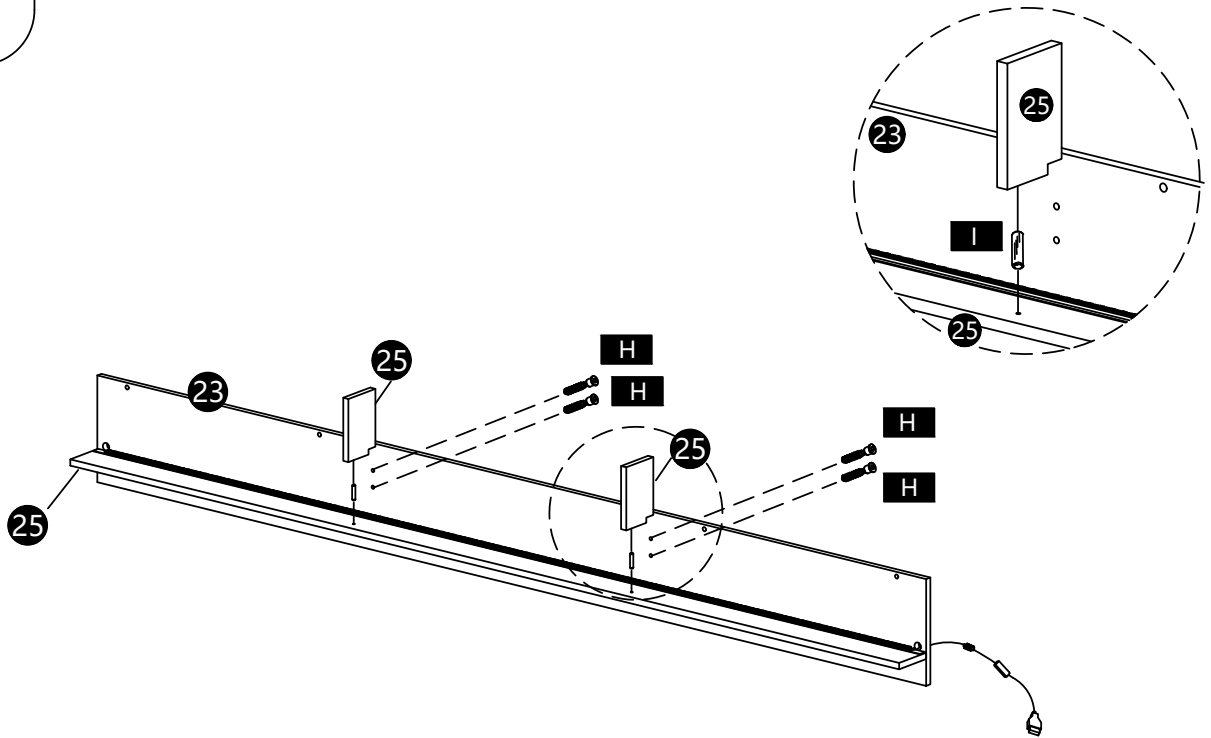

H

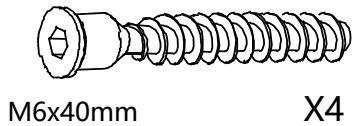

I

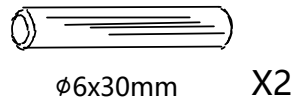

K

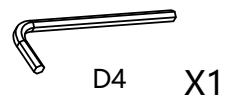

8

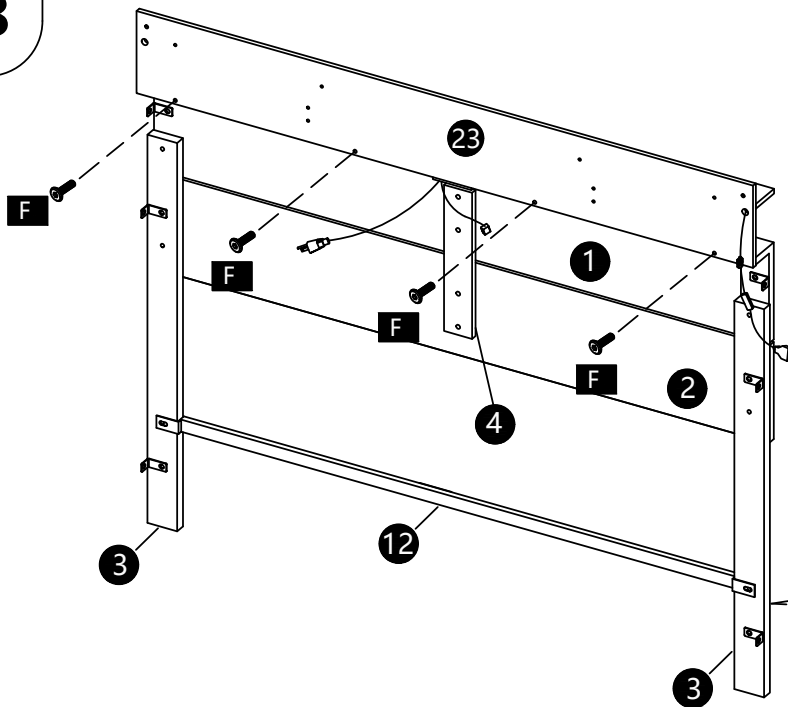

Two persons are needed.  
Deux personnes sont nécessaires.  
Zwei Personen sind erforderlich.  
Sono necessarie due persone.  
Se necesitan dos personas.  
必ず2人で作業してください。  
※需要另1个人协助。

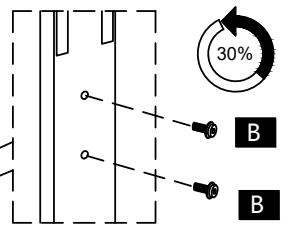
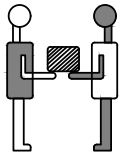

Pre-install 30% of the screw process.

F

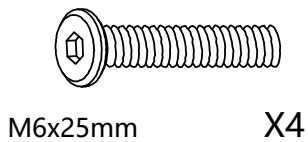

B

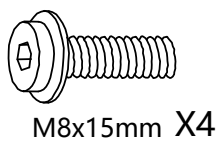

L

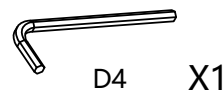

9

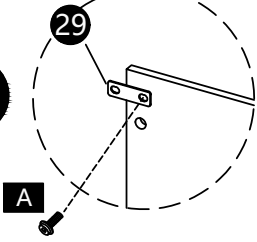

Pre-install 80% of the screw process.

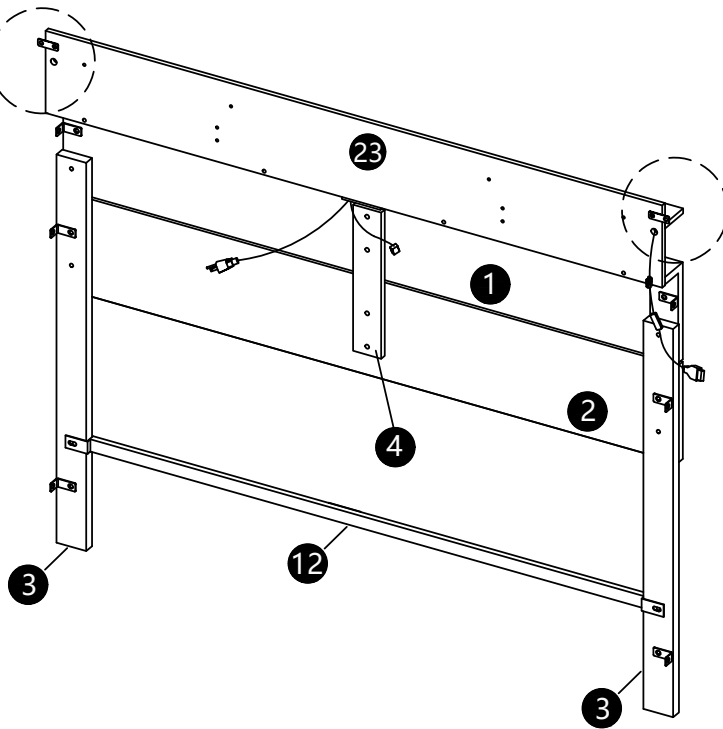

A

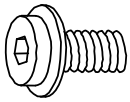

M8x10mm X2

29



X2

10

B

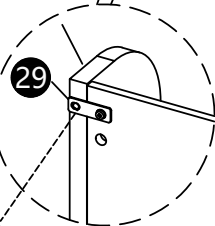

Screw installation is 80%.

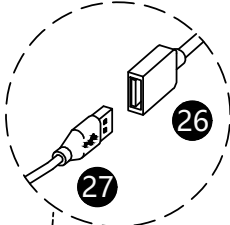

Two persons are needed.  
 Deux personnes sont nécessaires.  
 Zwei Personen sind erforderlich.  
 Sono necessarie due persone.  
 Se necesitan dos personas.  
 必ず2人で作業してください。  
 ※需要另1个人协助。

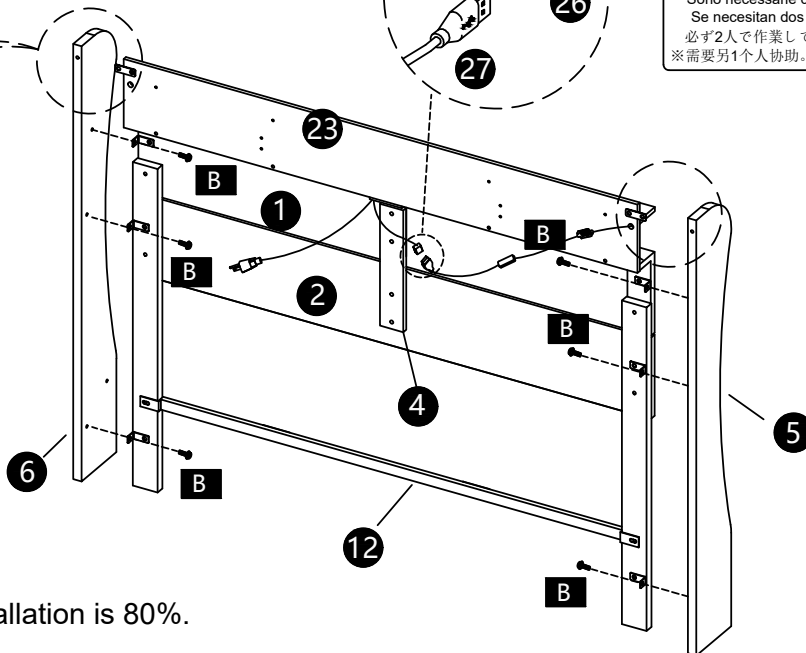
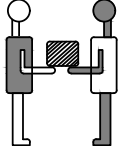

B

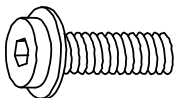

M8x15mm X8

J

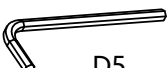

D5 X1

11

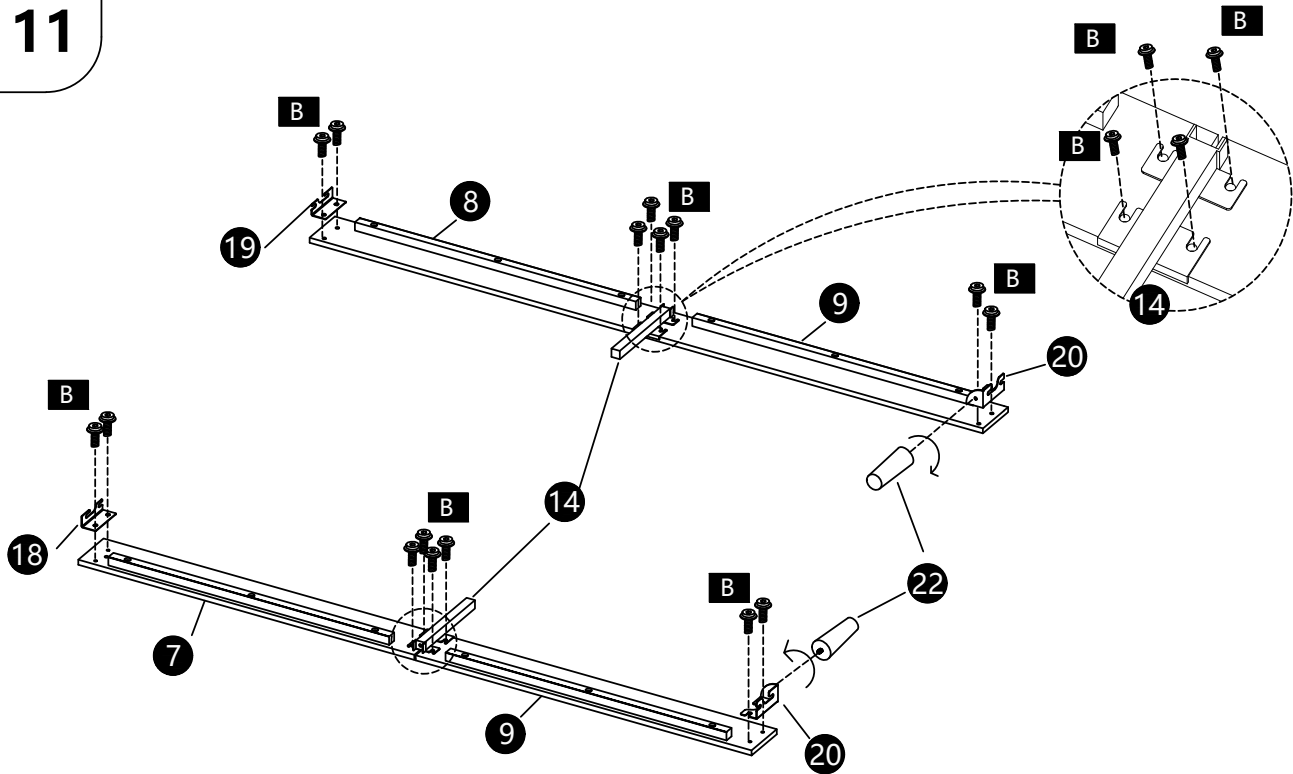

**B**

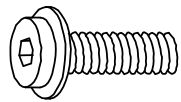

M8x15mm X16

**M**



D5

X1

12

Two persons are needed.  
 Deux personnes sont nécessaires.  
 Zwei Personen sind erforderlich.  
 Sono necessarie due persone.  
 Se necesitan dos personas.  
 必ず2人で作業してください。  
 ※需要另1个人协助。

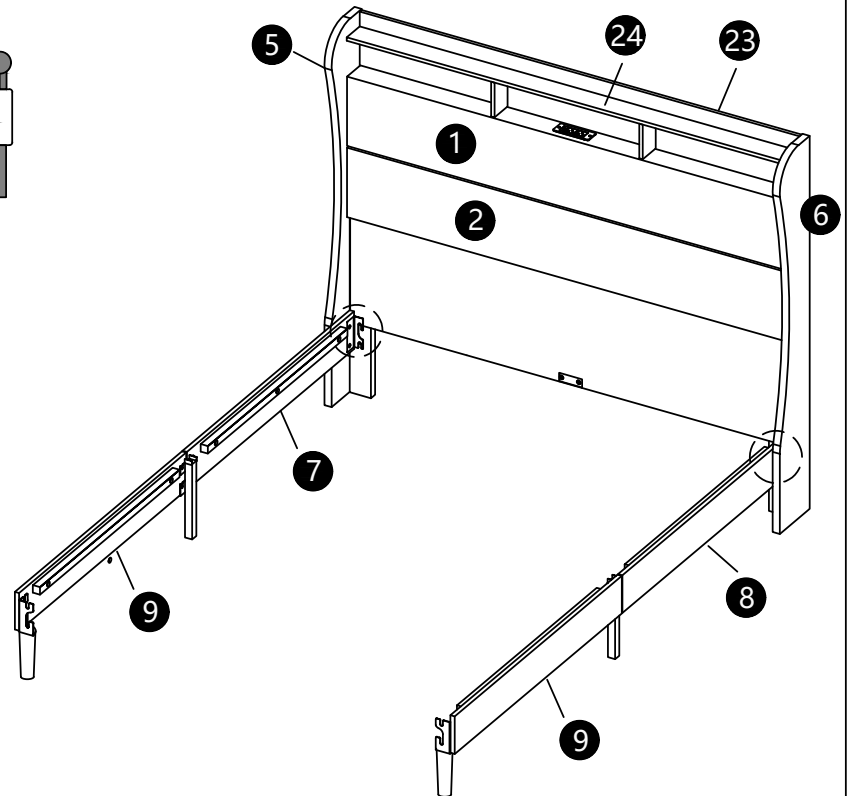
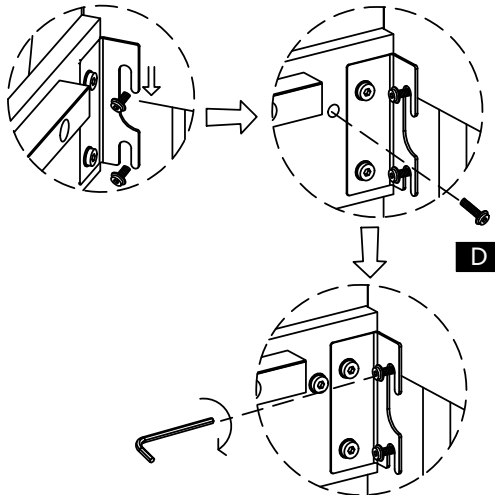
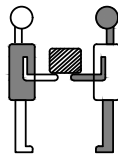

**D**

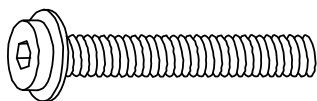

M8x35mm X2

**J**



D5

X1

13

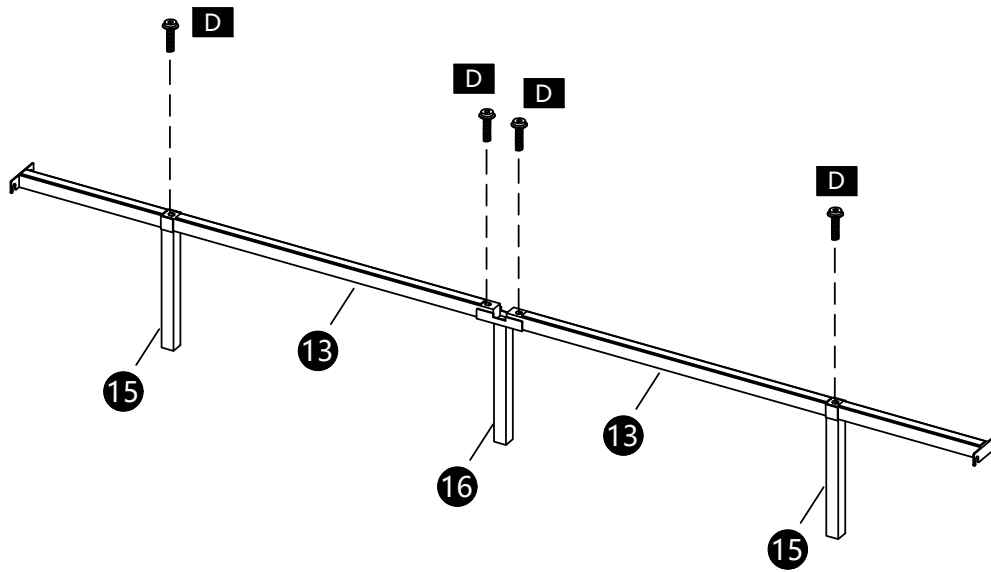

D

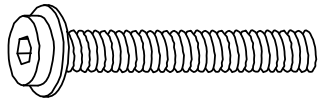

M8x35mm X4

J



D5 X1

14

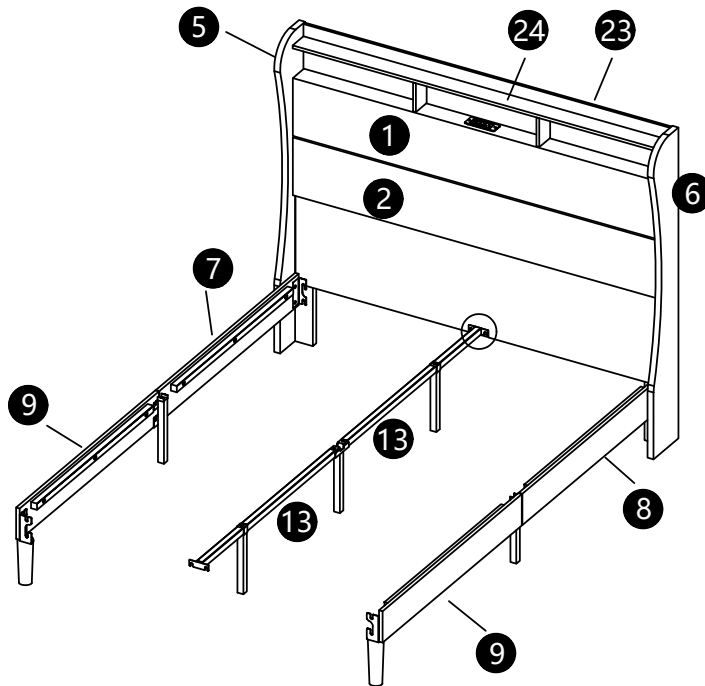

Two persons are needed.  
Deux personnes sont nécessaires.  
Zwei Personen sind erforderlich.  
Sono necessarie due persone.  
Se necesitan dos personas.  
必ず2人で作業してください。  
※需要另1个人协助。

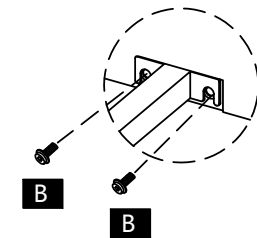
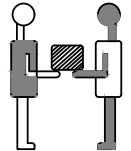

B

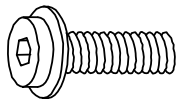

M8x15mm X2

J



D5 X1

15

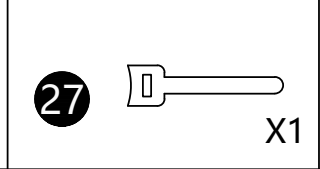
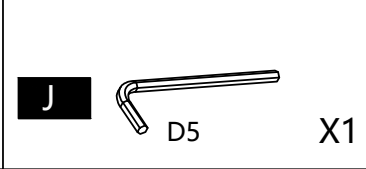
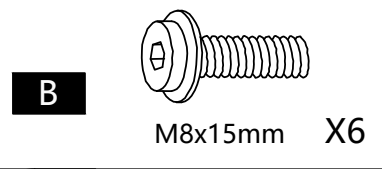
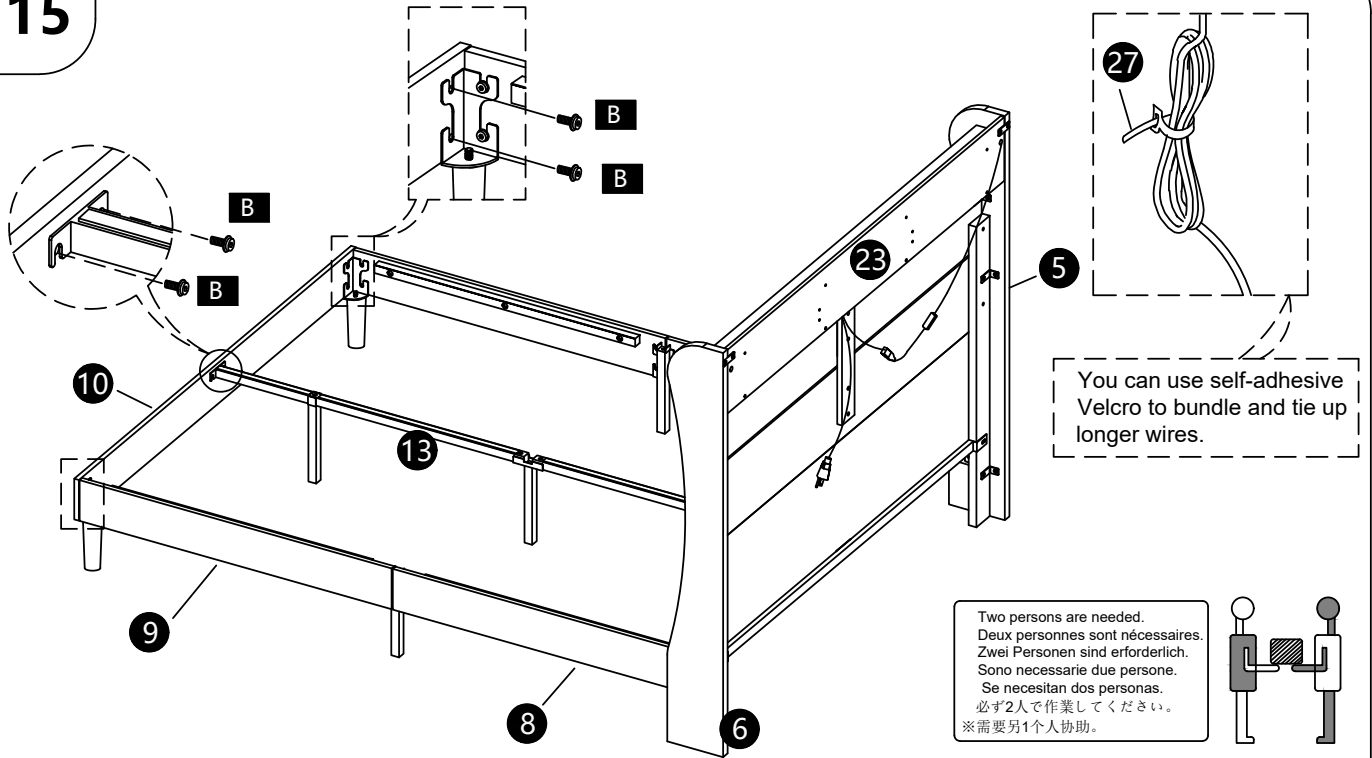

16

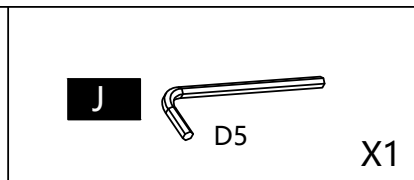
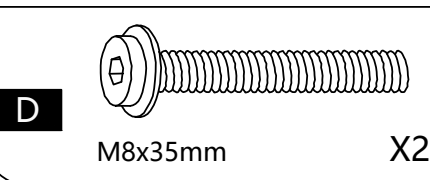
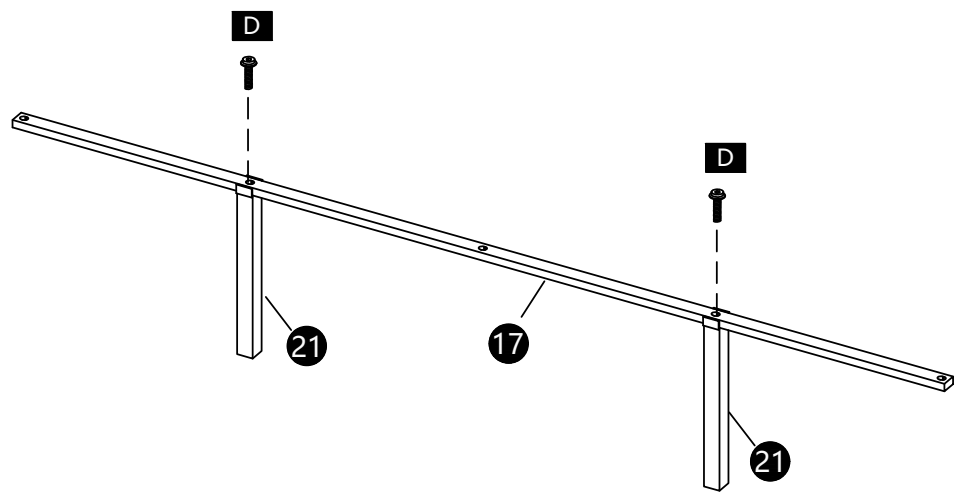

17

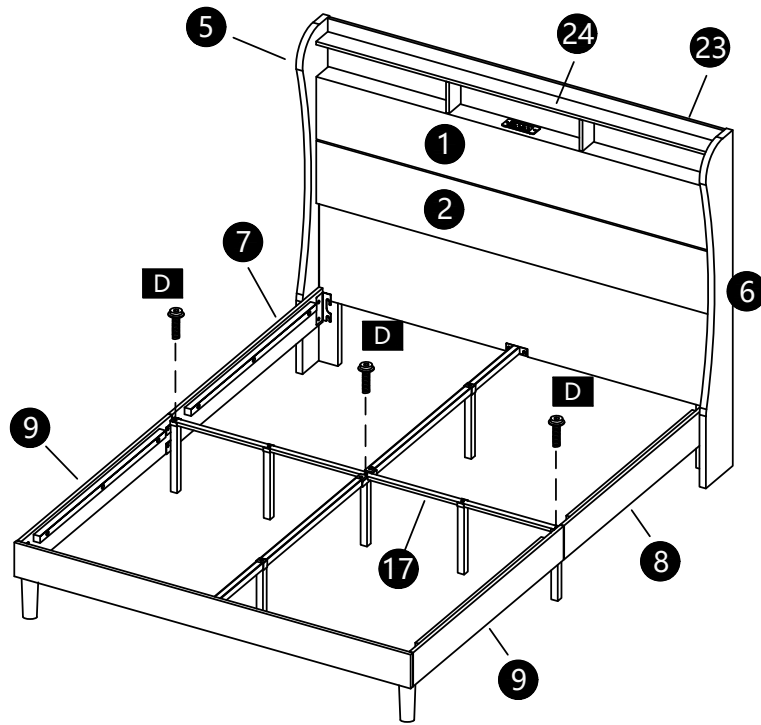

D

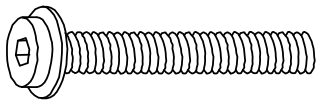

M8x35mm

X3

J



D5

X1

18

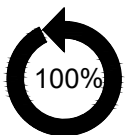
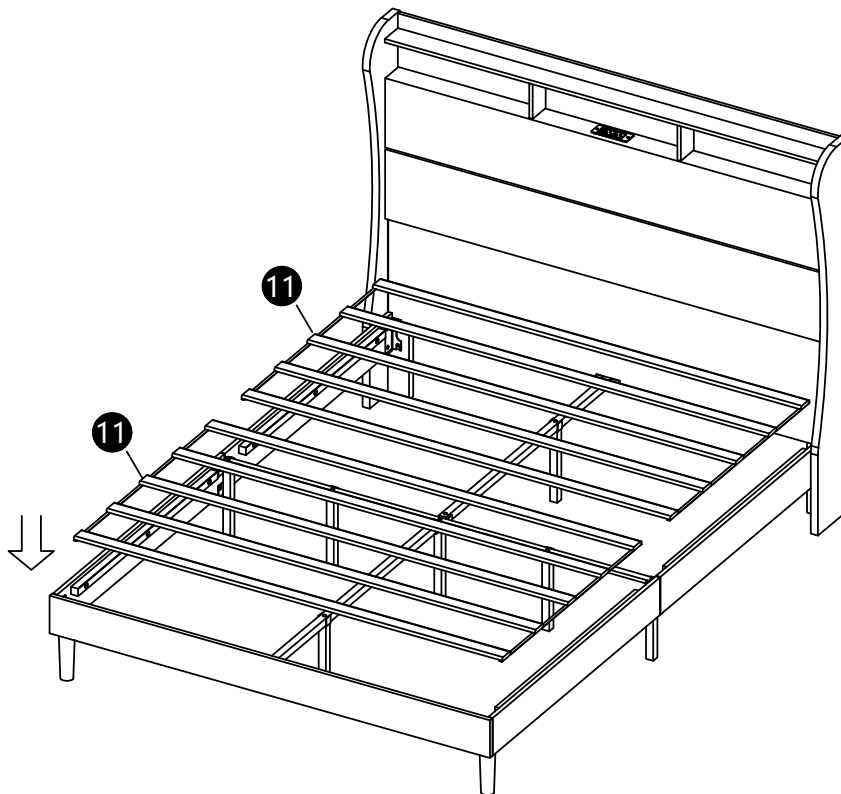

All screws are 100% tightened.