

# FULL BED & QUEEN BED

## Assembly Instructions

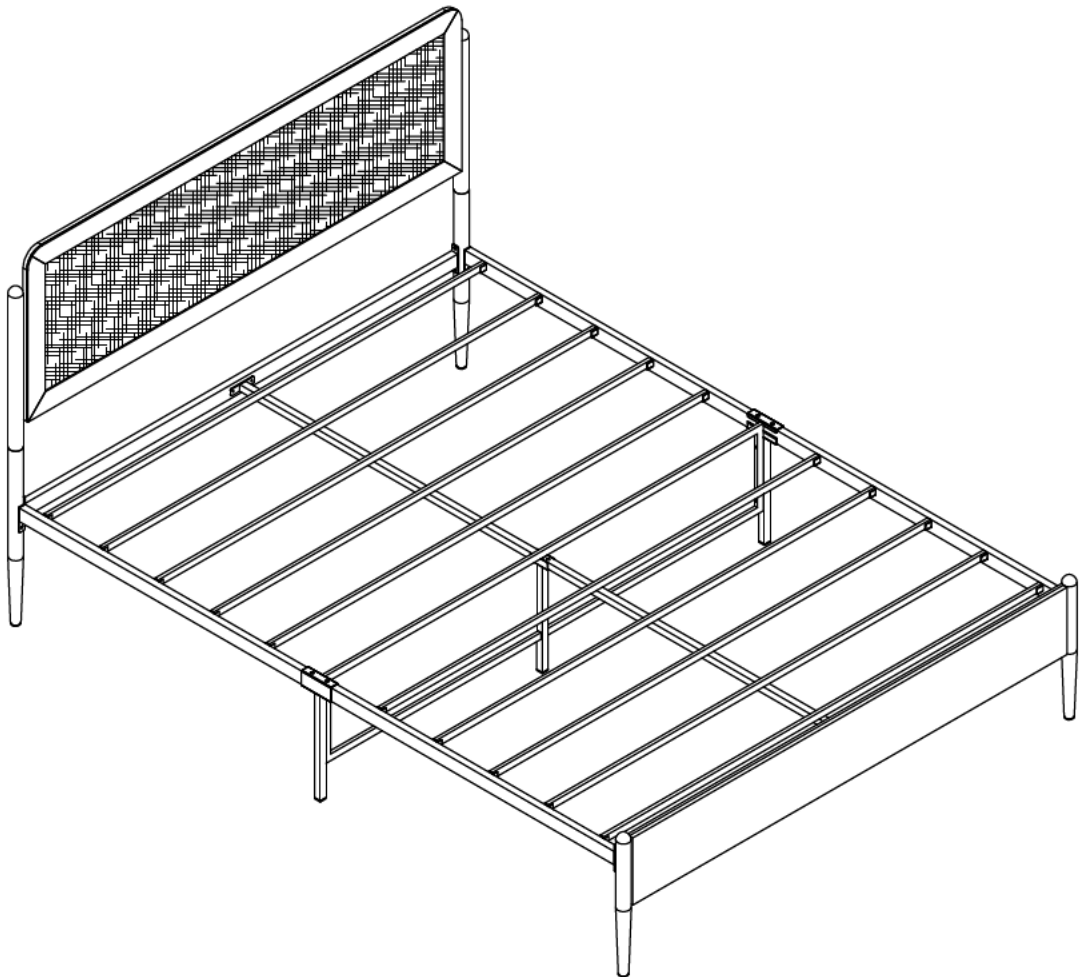

## YOU NEED

### 1. Tools required

A Phillips head screw driver is required for the assembly of this product. (not included)  
Electric tool should not be used to assemble this product.

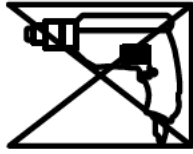

### 2. Two people are needed



### 3. Installation takes 60 minutes



### 4. Technical Specifications

Max weight capacity	700lbs
---------------------	--------



## **IMPORTANT SAFETY INFORMATION**

- **Please carefully read the following instructions and caution warnings before assembling the product.**
- **Following this guide will ensure that you install, use and maintain the product properly.**
- **Please keep this installation and user manual/instructions for future reference in case you need to disassemble the product.**
- **Never allow children to climb onto the product. Ensure that you have special safety measures when children are around on their own.**
- **Be sure to check that all parts of the product are intact after you open the package.**
- **Do not assemble if you notice serious damage such as cracks or bends.**
- **During installation, please use work gloves for hand safety.**
- **Please assemble the unit on carpeted floor or the flat cardboard box to avoid scratching the surface or your floor while assembling on the floor.**
- **To assemble, please use the complimentary installation tools (Phillips screwdriver). Pay more attention to the direction of components at each steps.**
- **It is recommended that two people work together to assemble the product.**

## **RETURN POLICY**

- **Please contact us directly within 30 days after receiving.**
- **Ensure the product is in a good condition with the original box and all original certificates of purchase, manuals, and accessories attached.**

## **How to maintain your product**

- **Check the screws of the product are not loose from regular use.**
- **Do not use sharp instruments, rubbing alcohol, corrosive chemicals, or abrasive cleaners to clean the item.**

# HARDWARE LIST

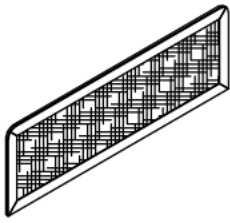

①

1PC

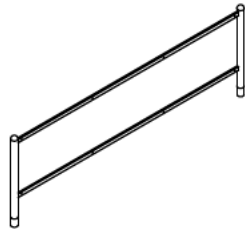

②

1PC

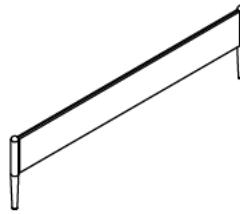

③

1PC

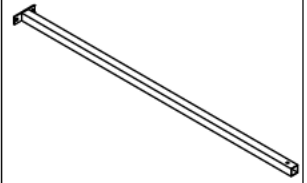

④

1PC

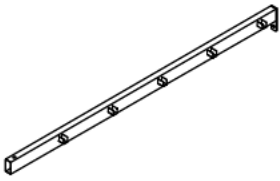

⑤

1PC

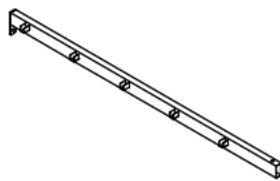

⑥

1PC

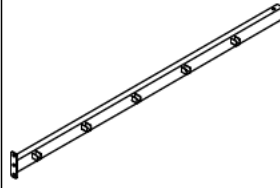

⑦

1PC

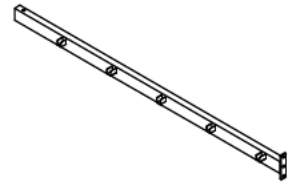

⑧

1PC



⑨

2PCS

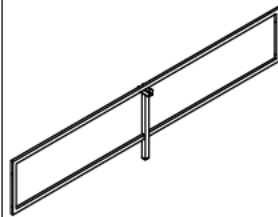

⑩

1PC



⑪

10PCS

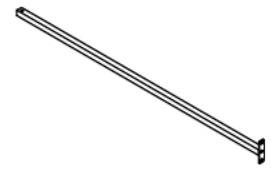

⑫

1PC



⑬

1PC



⑭



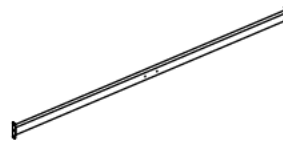





1PC



⑮

1PC

**COMPONENTS ID Nr.**

<b>A</b>		<b>M8*15</b>	<b>Bolt cap: Ø15</b>	<b>4PCS</b>
<b>B</b>		<b>M6*12</b>	<b>Bolt cap: Ø11</b>	<b>10PCS</b>
<b>C</b>		<b>M8*50</b>	<b>Bolt cap: Ø15</b>	<b>2PCS</b>
<b>D</b>		<b>M6*32</b>	<b>Bolt cap: Ø15</b>	<b>6PCS</b>
<b>E</b>		<b>M6*10</b>	<b>Bolt cap: Ø15</b>	<b>4PCS</b>
<b>F</b>		<b>M6*30</b>	<b>Bolt cap: Ø11</b>	<b>4PCS</b>
<b>G</b>		<b>M6*18</b>	<b>Bolt cap: Ø11</b>	<b>8PCS</b>
<b>H</b>		<b>M6*20</b>	<b>Bolt cap: Ø13</b>	<b>6PCS</b>
<b>I</b>		<b>M4</b>		<b>1PCS</b>

# PRODUCT ASSEMBLY

## Step 1

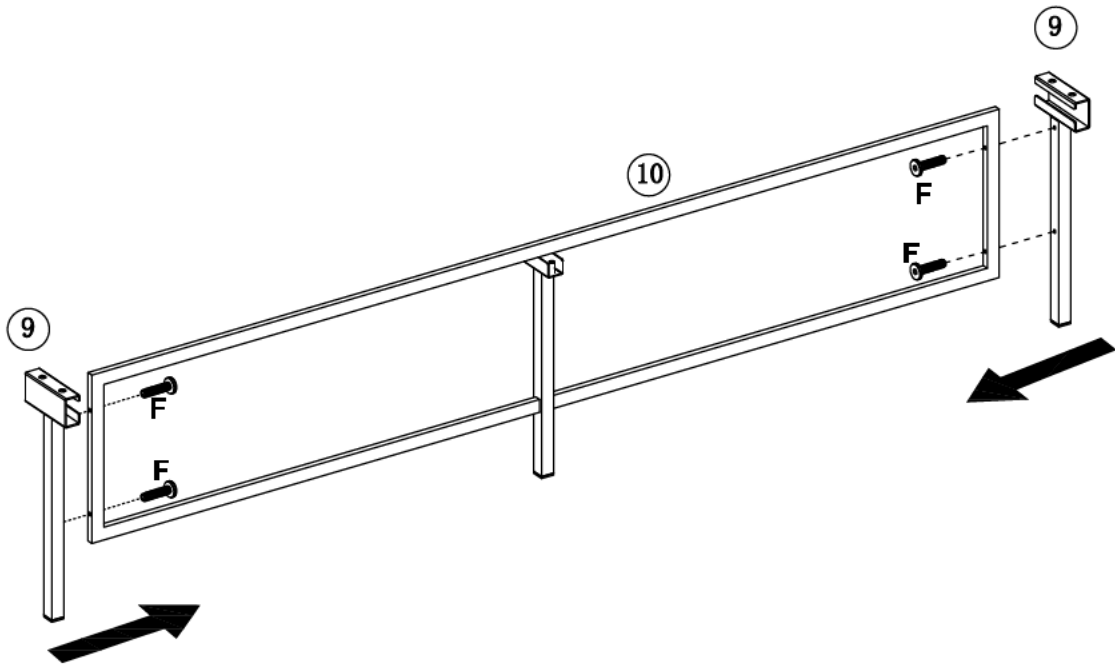
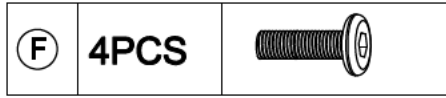

## Step 2

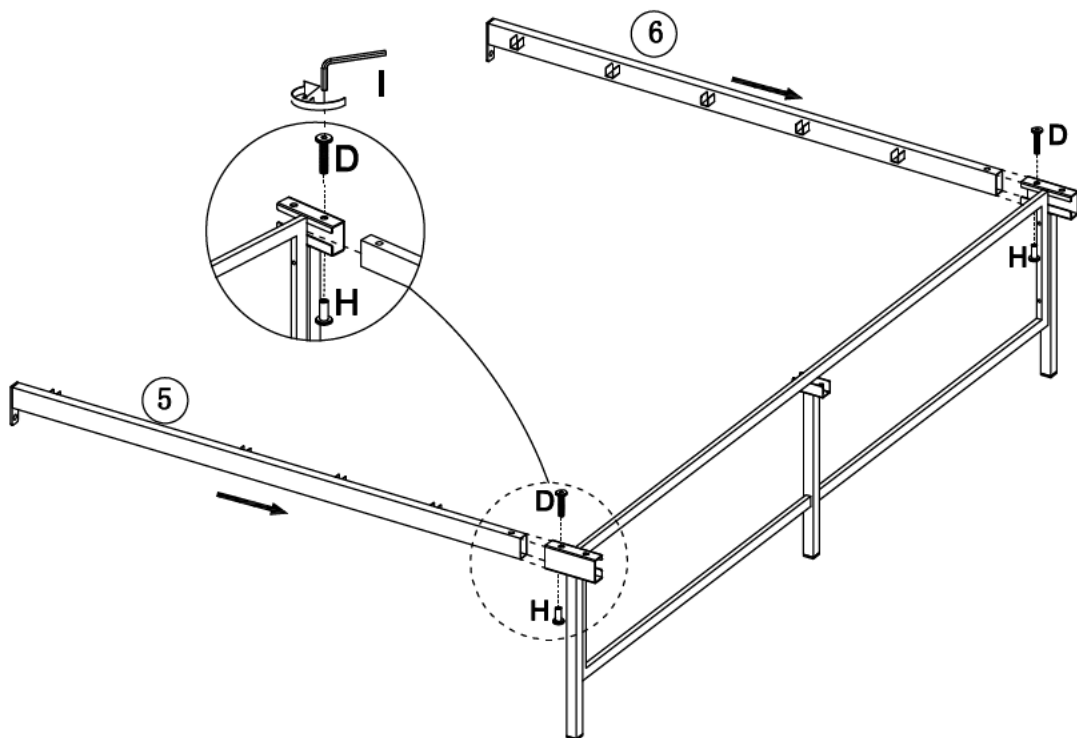

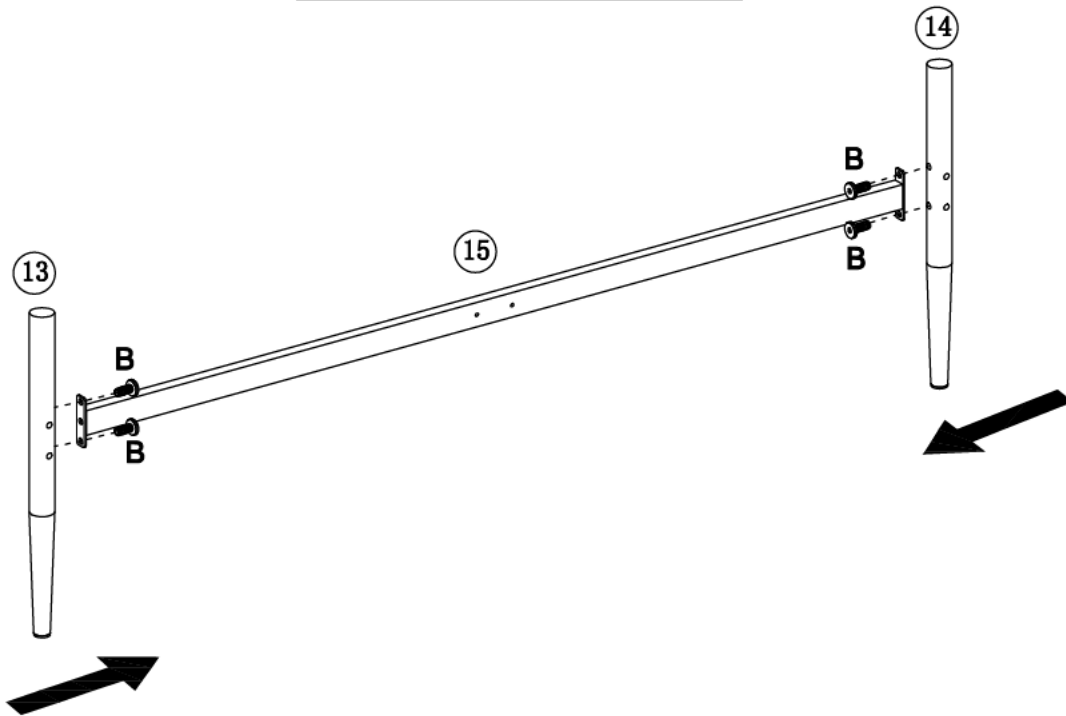

### Step 3

(B)	4PCS	
-----	------	---



### Step 4

(C)	2PCS		(H)	2PCS	
(D)	2PCS				

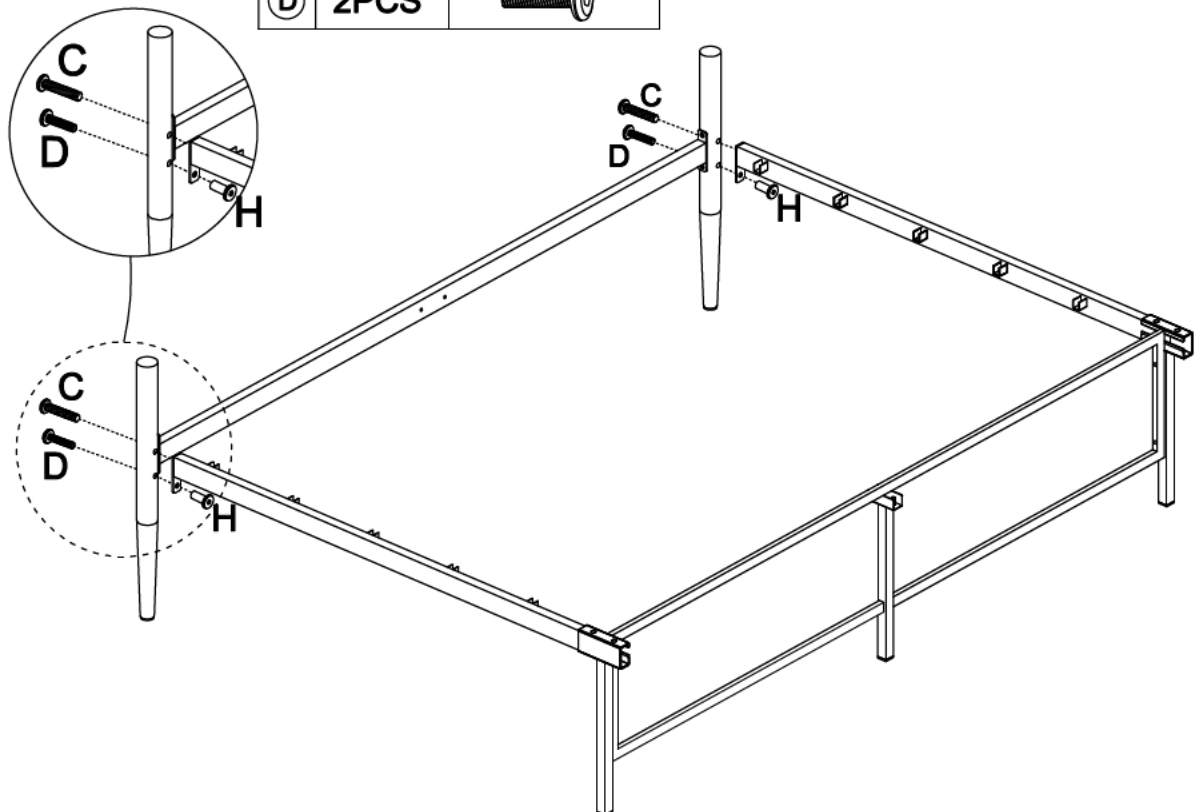

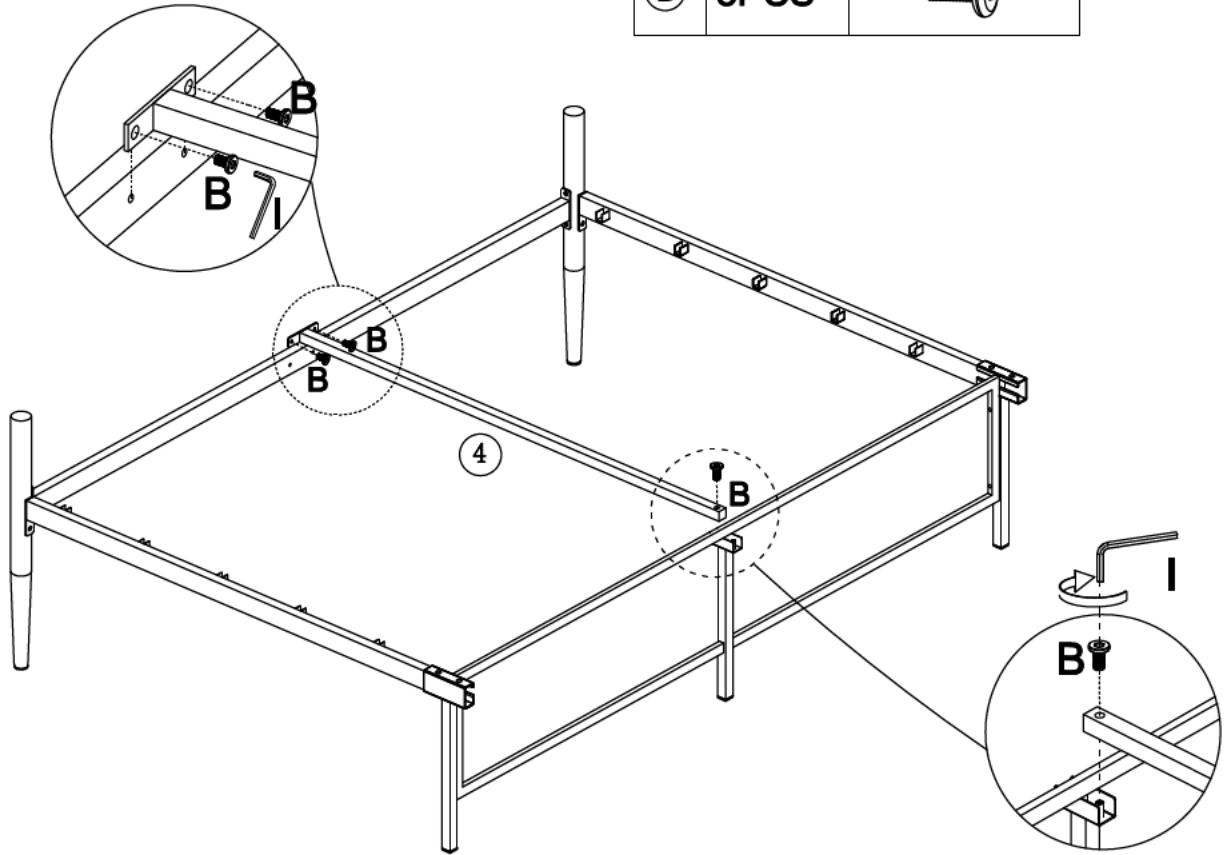

### Step 5

(B)	3PCS	
-----	------	---



### Step 6

(D)	2PCS	
(H)	2PCS	

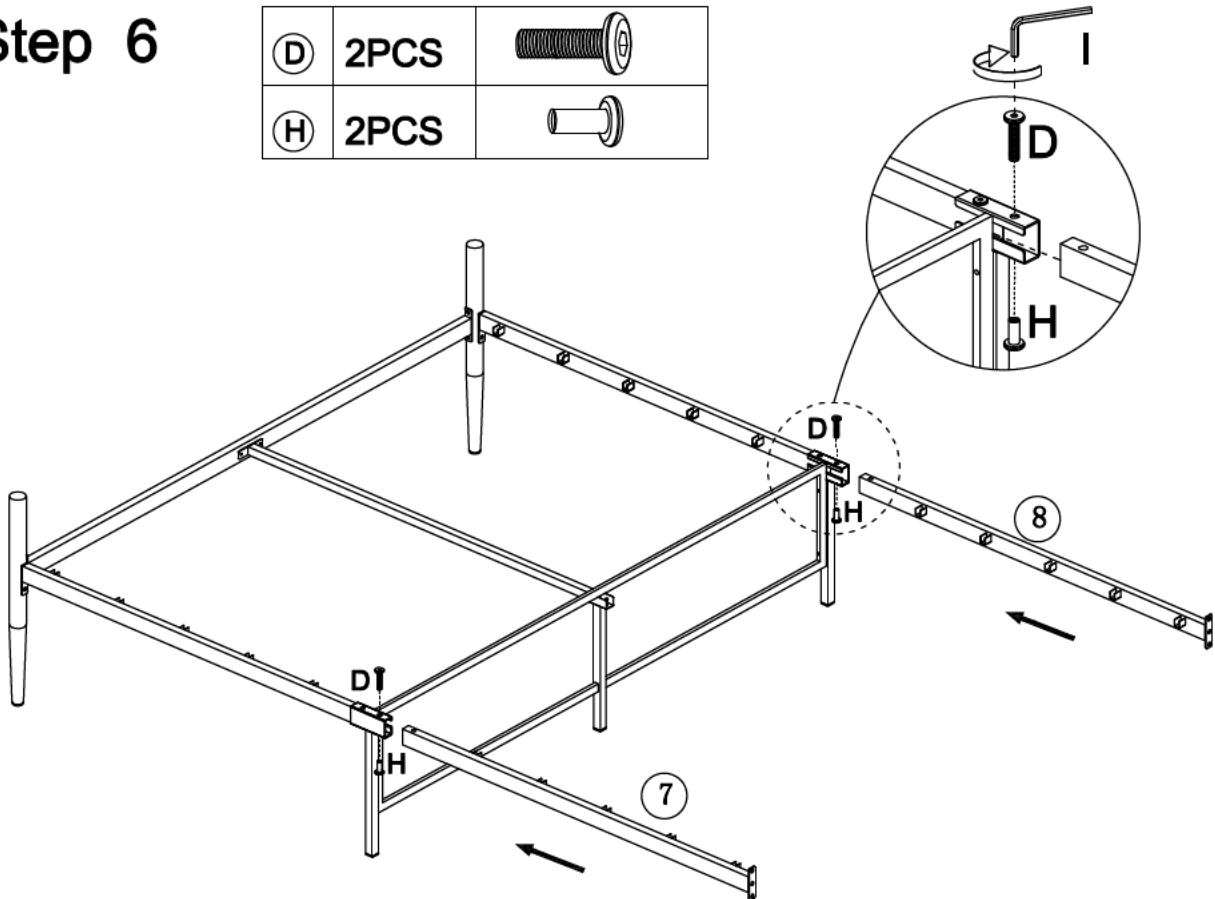

# Step 7

<b>(A)</b>	<b>4PCS</b>	
------------	-------------	---

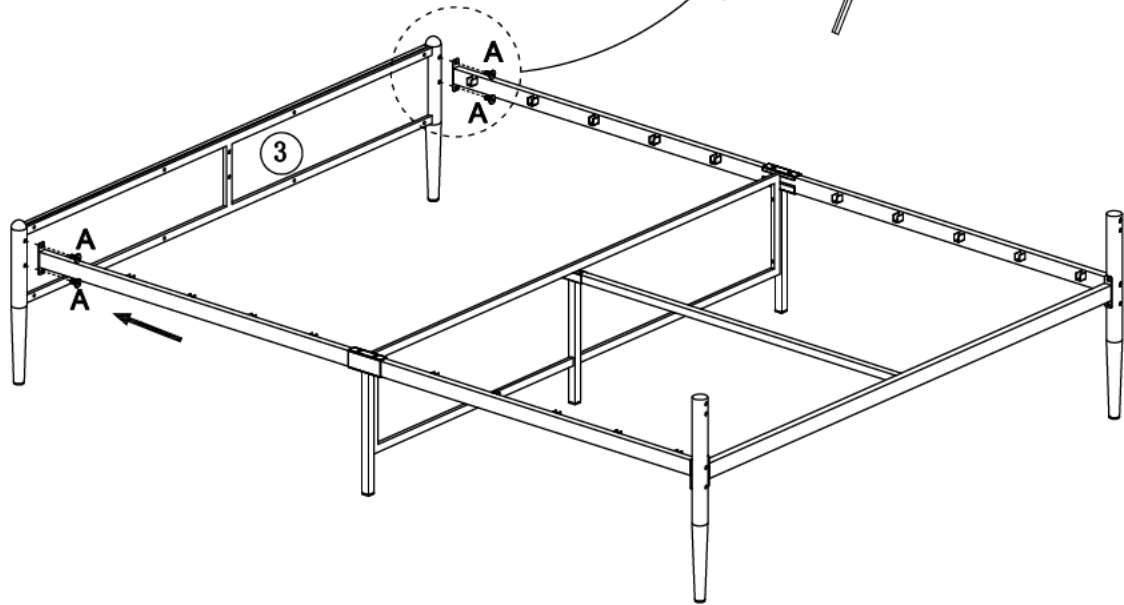
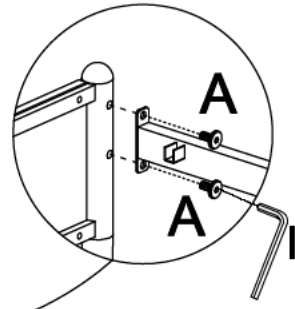

# Step 8

<b>(B)</b>	<b>3PCS</b>	
------------	-------------	---

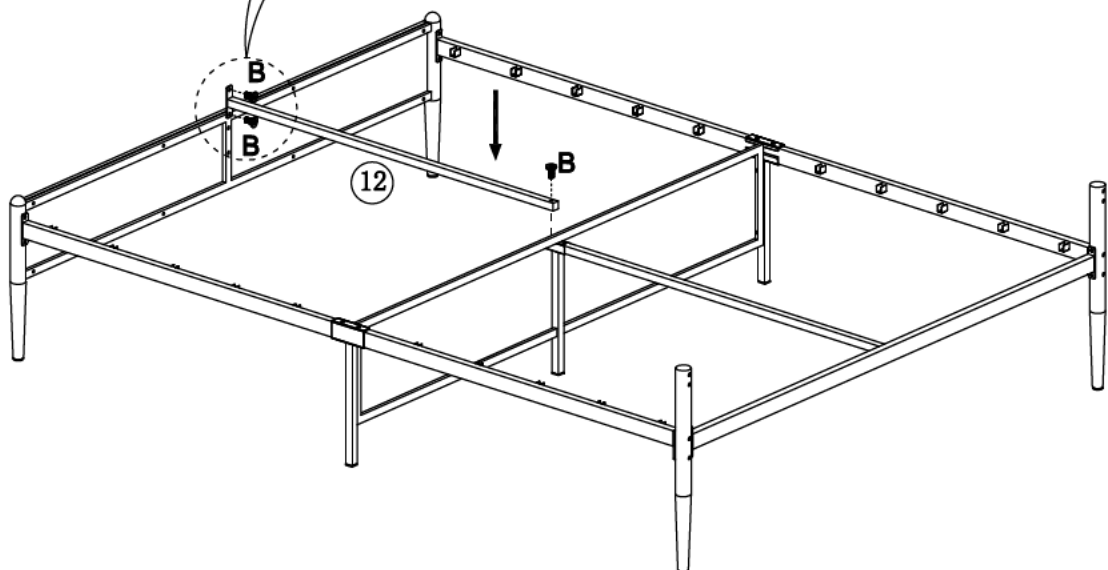
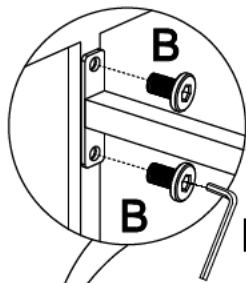

**PRODUCT ASSEMBLY**

**Step 9**

ⓐ	8PCS	
---	------	---

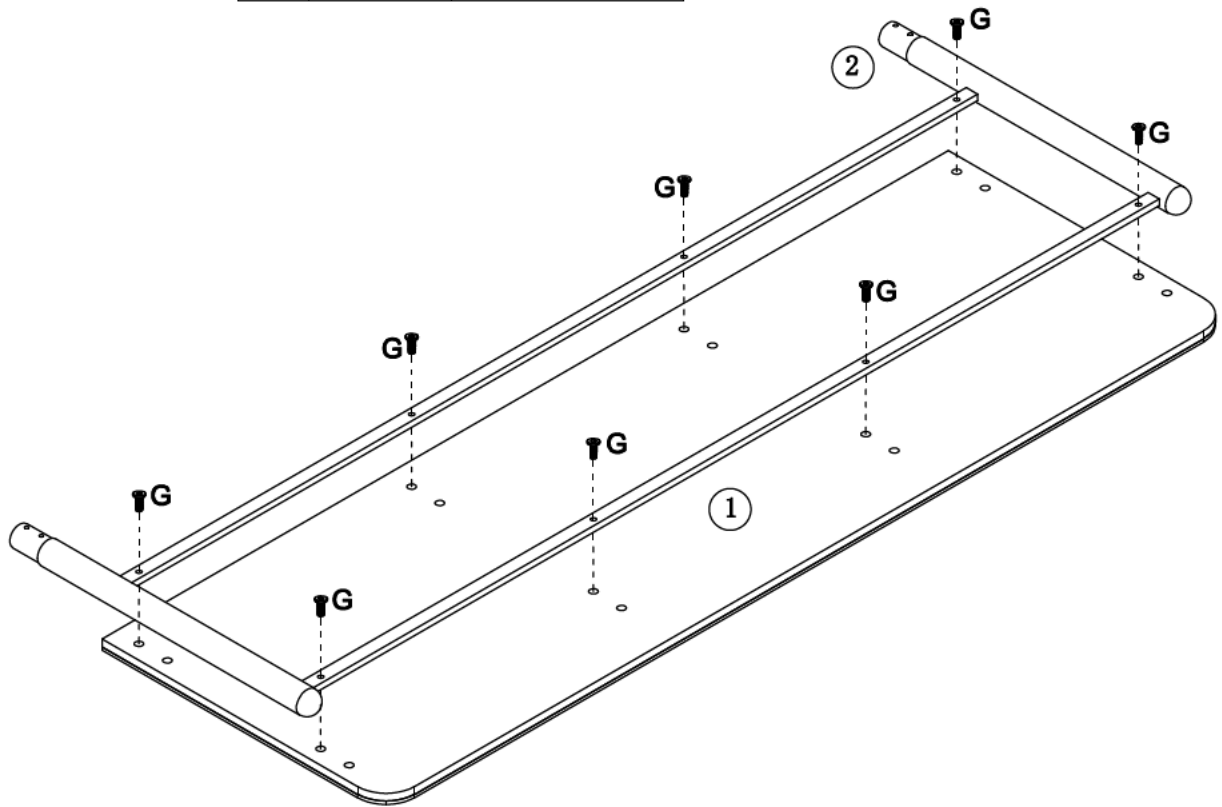

**Step 10**

ⓔ	4PCS	
---	------	---

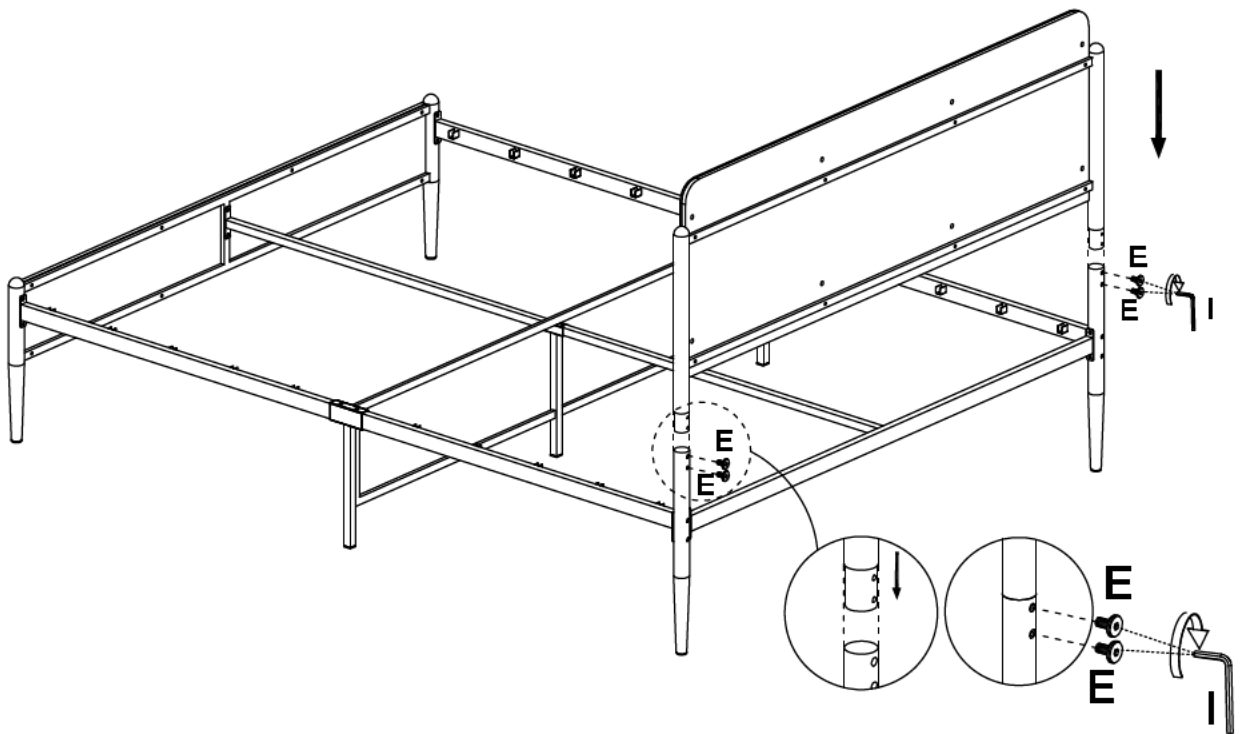

# Step 11

