

Assembly Instructions

Bar Table

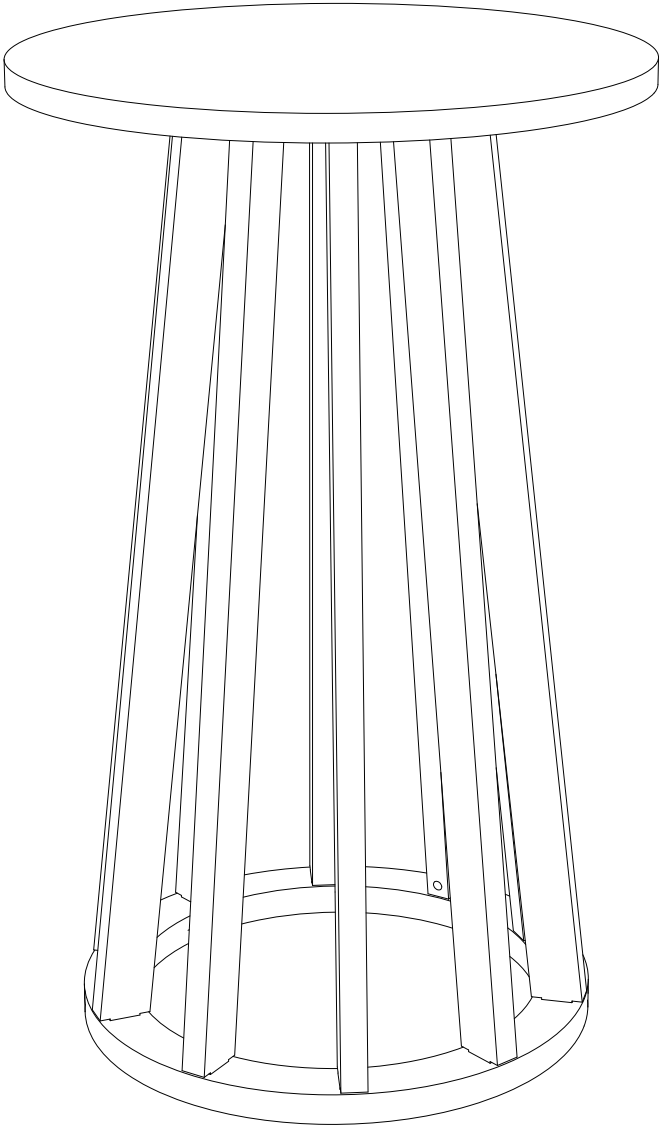

Contact Us

We're here to help you.

Your satisfaction is our top priority. If you encounter any issues with this product, such as missing or damaged parts, we're here to help. Please retain the original packaging and take photos of the packaging and the product, then contact us as soon as possible.

Warm Tips

1. Carefully read these instructions and keep them for future reference.
2. Check the parts list and confirm everything's there before starting assembly.
3. When assembling, put all parts on a soft, smooth surface like a carpet to avoid scratches.
4. Don't fully tighten screws until all parts are confirmed in place to avoid misalignment.

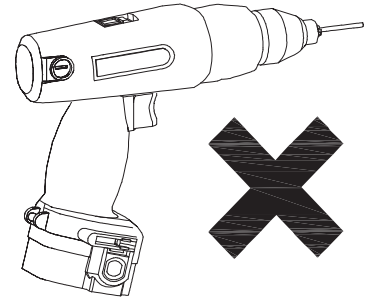
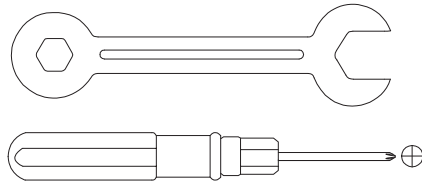
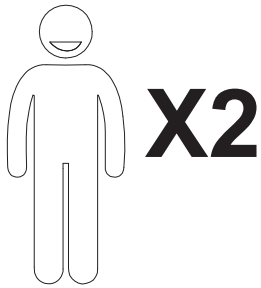

We recommend using hand tools for assembly.

If an electric screwdriver is used, reduce power and torque to avoid damage to the product.

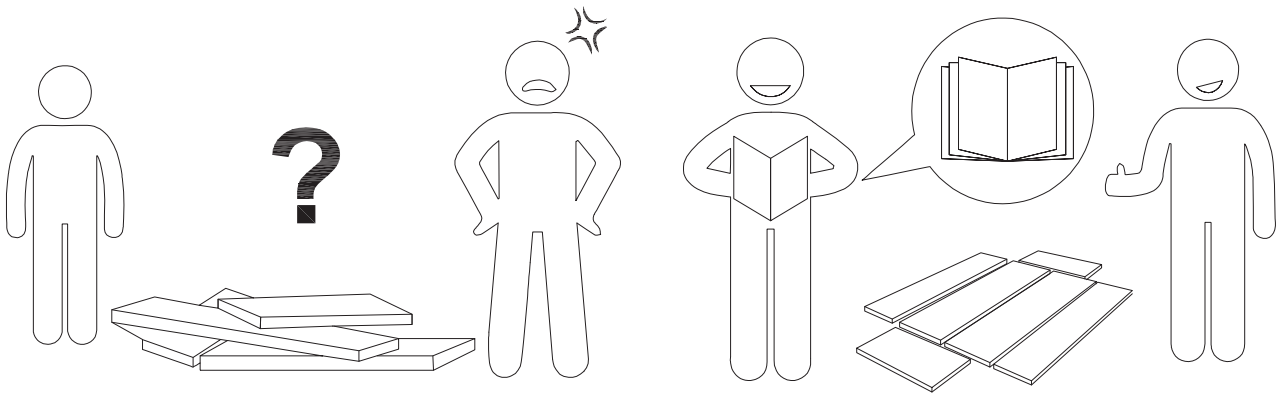

AVOID SCRATCHES

In order to avoid scratching, this furniture should be assembled on a soft surface, such as a rug.

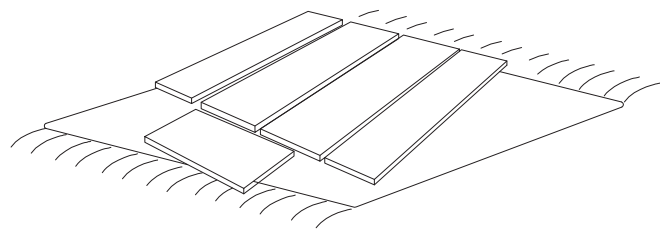
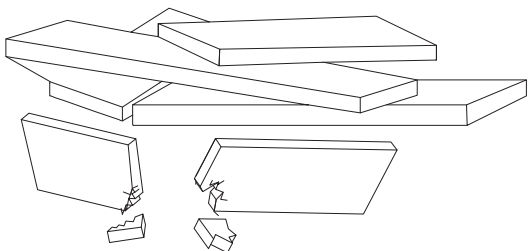

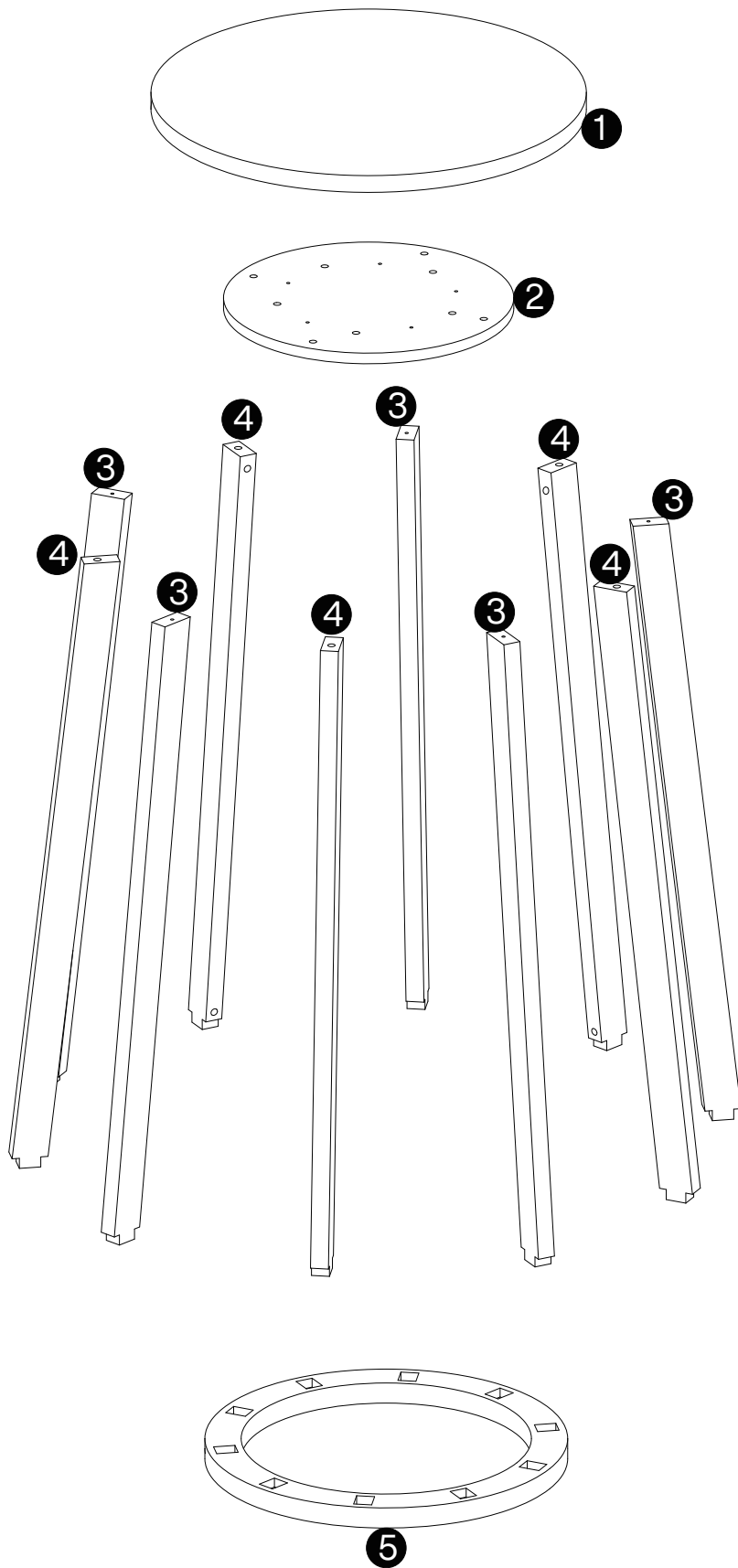



⚠ Caution

Make sure all parts are included. Most board parts are labeled or stamped on the raw edge. Contact us for a free replacement if you encounter any damaged or missing parts.

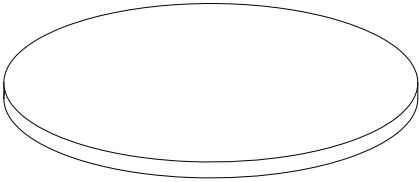
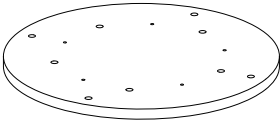
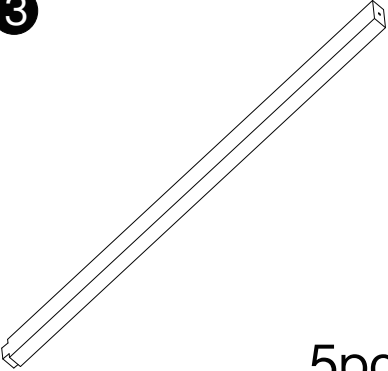
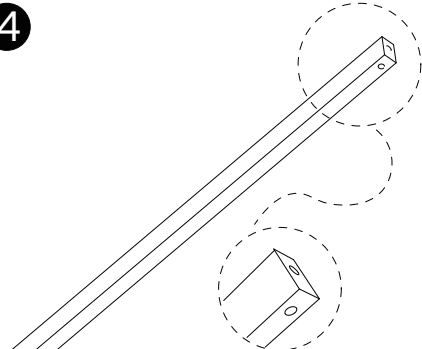
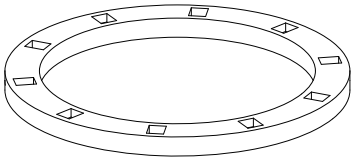
Parts List

<p>1</p>  <p>1pc</p>	<p>2</p>  <p>1pc</p>	
<p>3</p>  <p>5pcs</p>	<p>4</p>  <p>5pcs</p>	<p>5</p>  <p>1pc</p>

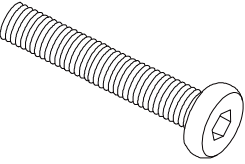
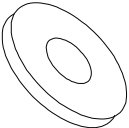
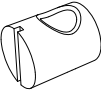
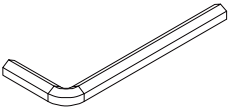
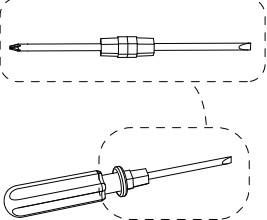
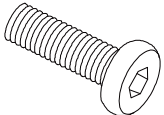
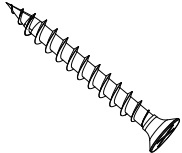
Hardware List



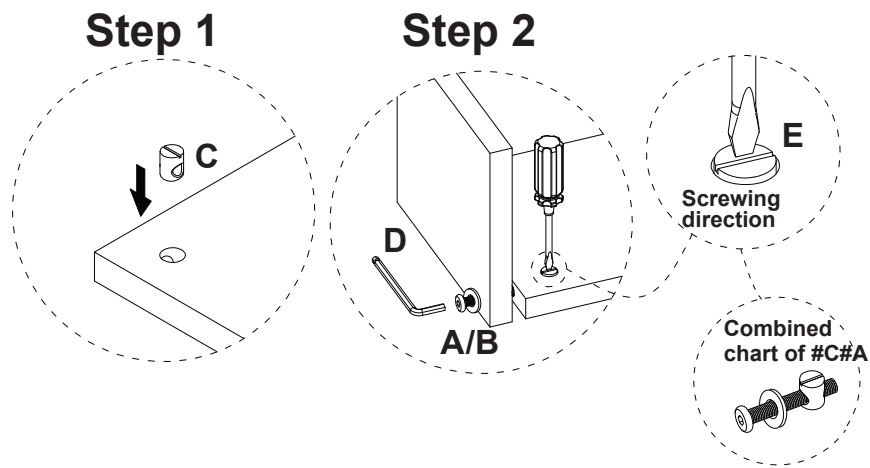

A	B	C	D	E
 <p>M6x65mm</p>				
<p>10+1pcs</p>	<p>14+1pcs</p>	<p>10+1pcs</p>	<p>1pc</p>	<p>1pc</p>
F	G	H		
 <p>M6x30mm</p>	 <p>M4x40mm</p>			
<p>4+1pcs</p>	<p>10+1pc</p>	<p>5pcs</p>		

1



Step 1: Insert #C into the hole.

Step 2: Using a screwdriver, rotate #C until its groove aligns with #A. Lock in place by turning #A clockwise.

A	B	C	D	E
				
M6X65 mm				
5pcs	5pcs	5pcs	1pc	1pc

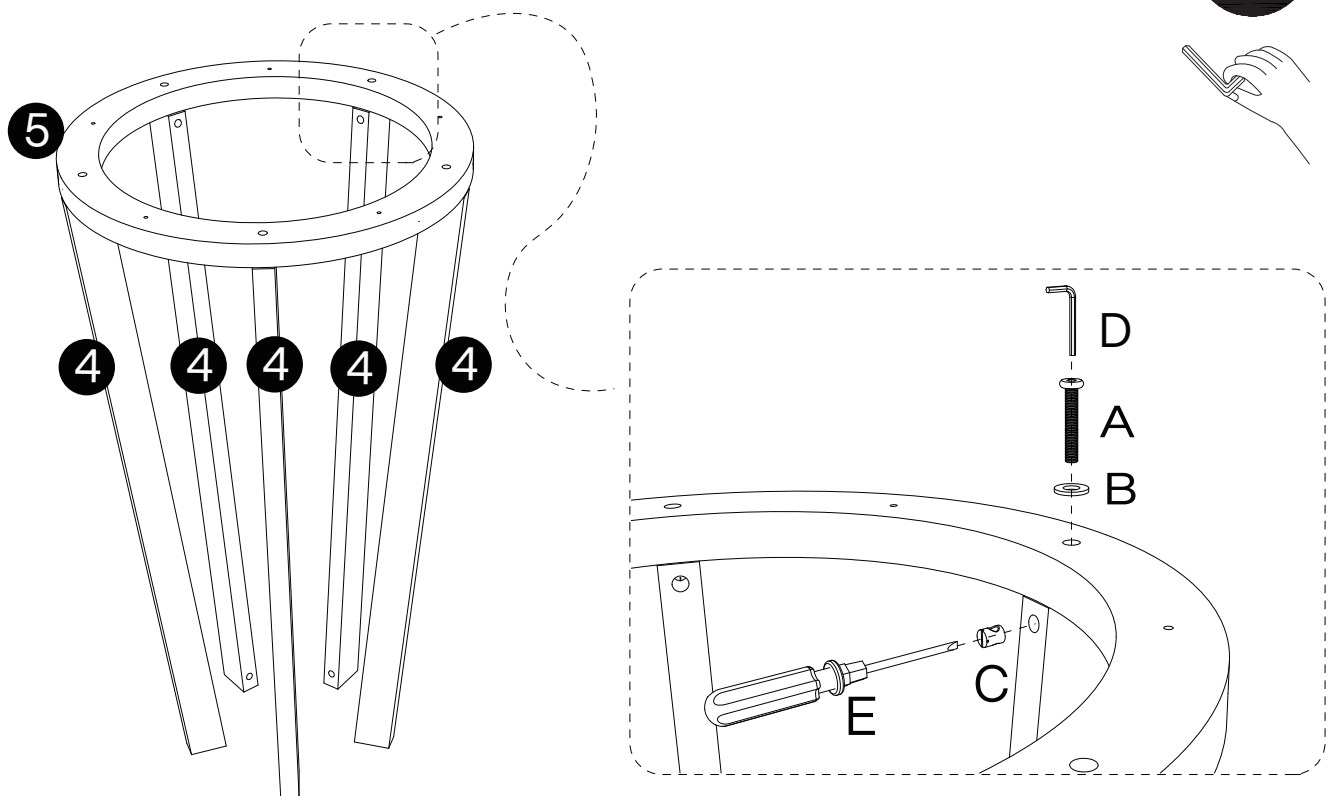
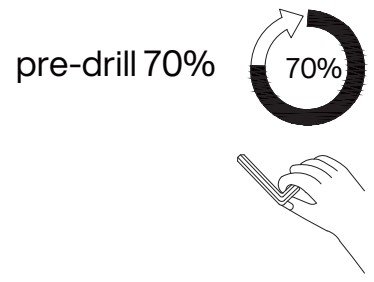



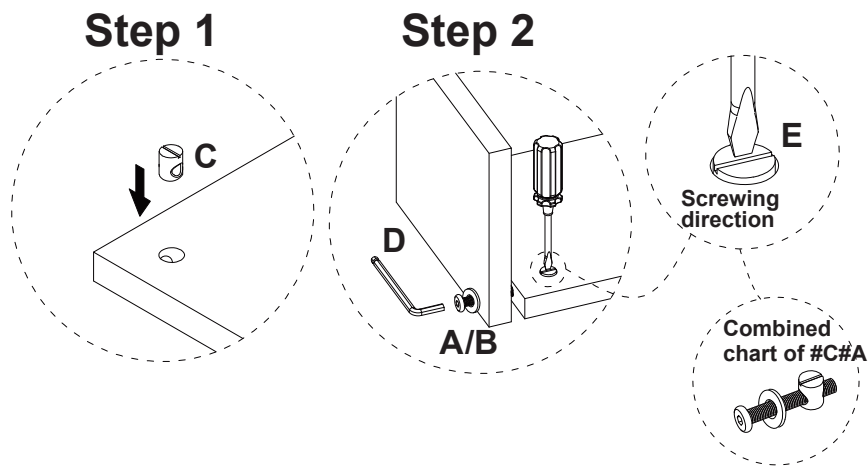

2



Step 1: Insert #C into the hole.

Step 2: Using a screwdriver, rotate #C until its groove aligns with #A. Lock in place by turning #A clockwise.

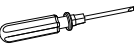
A	B	C	D	E
				
M6X65 mm				
5pcs	5pcs	5pcs	1pc	1pc

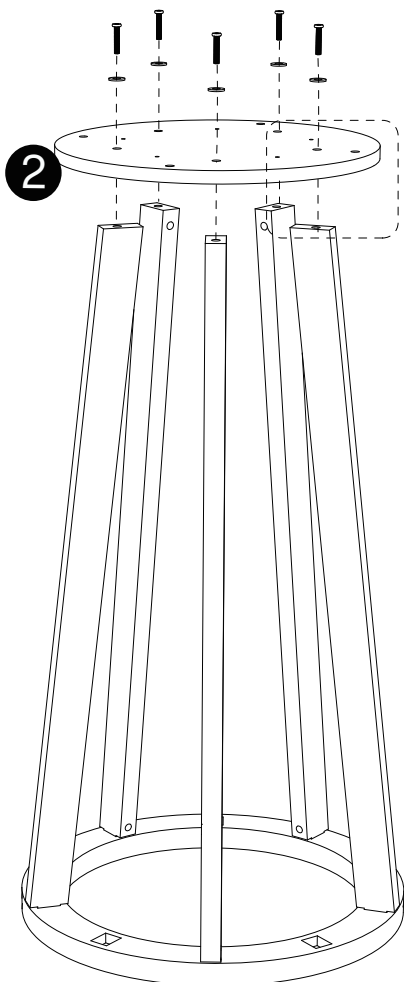

pre-drill 70% 

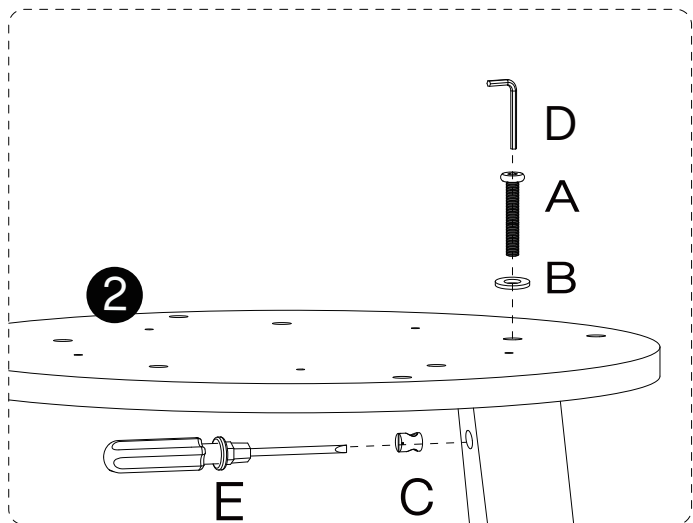

3

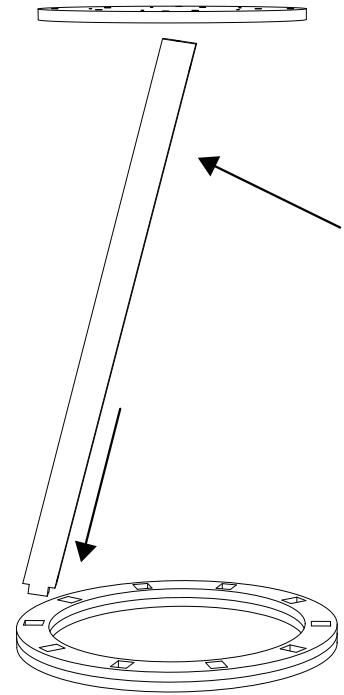
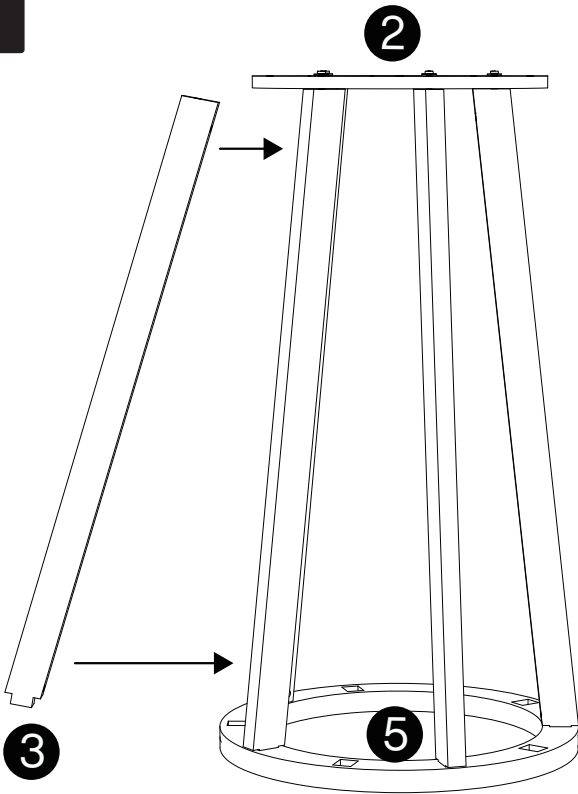

Step 1: Tilt and embed the protruding end of #3 into the groove of #5 (note orientation).
Step 2: Align #3 with the holes of #2 and tighten the screws to 70% torque.

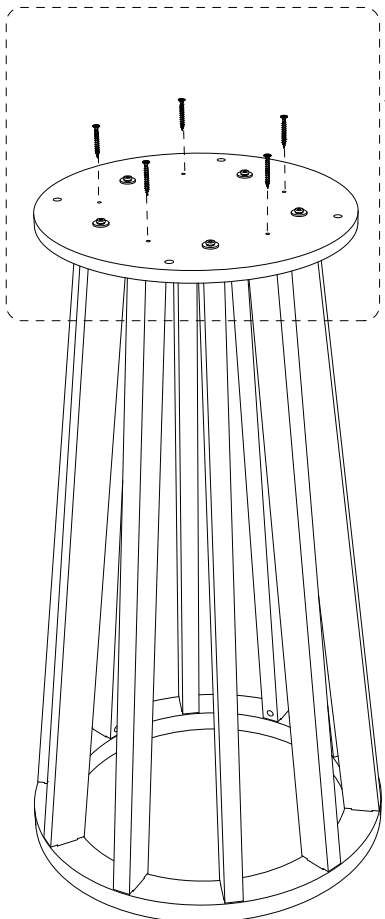

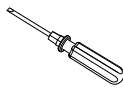
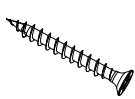
E	G
	
1pc	5pcs

pre-drill 70%

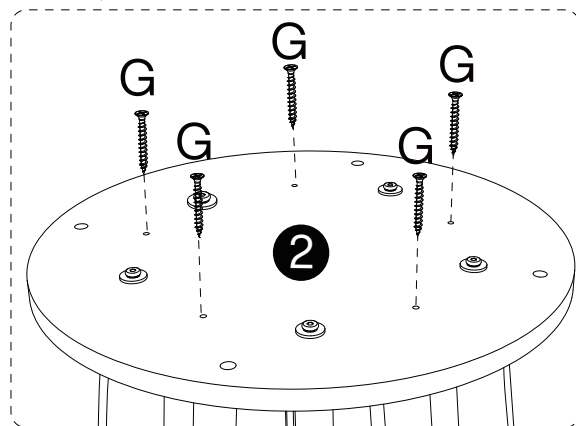

4

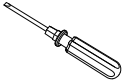
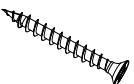
E	G
	
1pc	5pcs

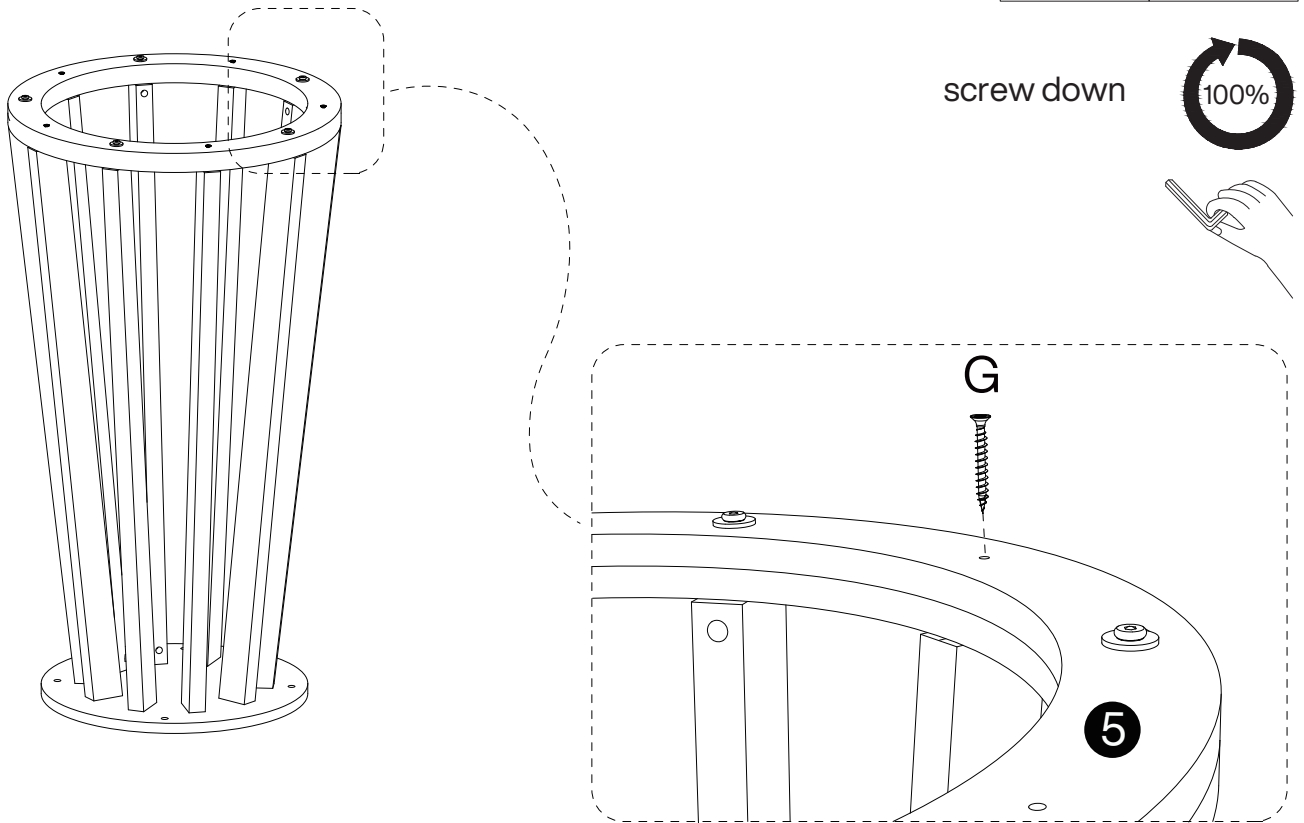

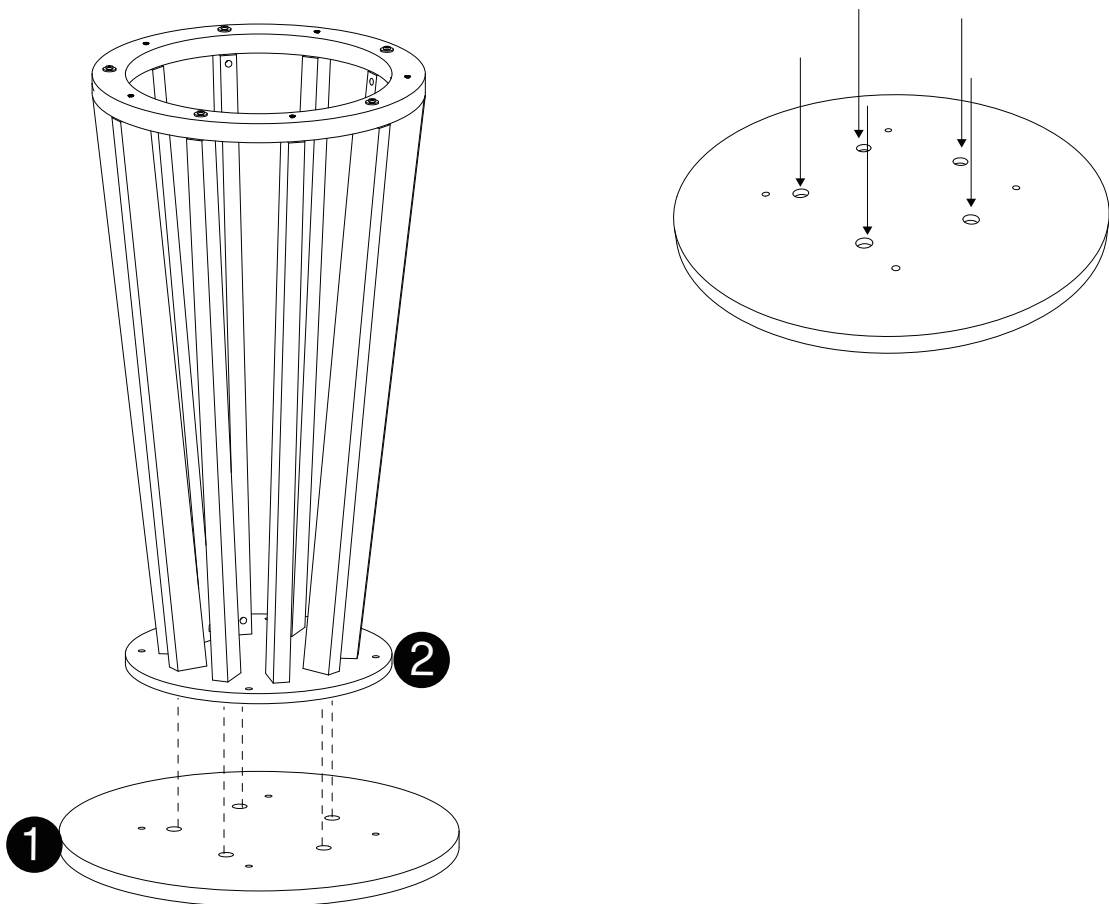

5

Align the screw in step 2 with the counterbore.

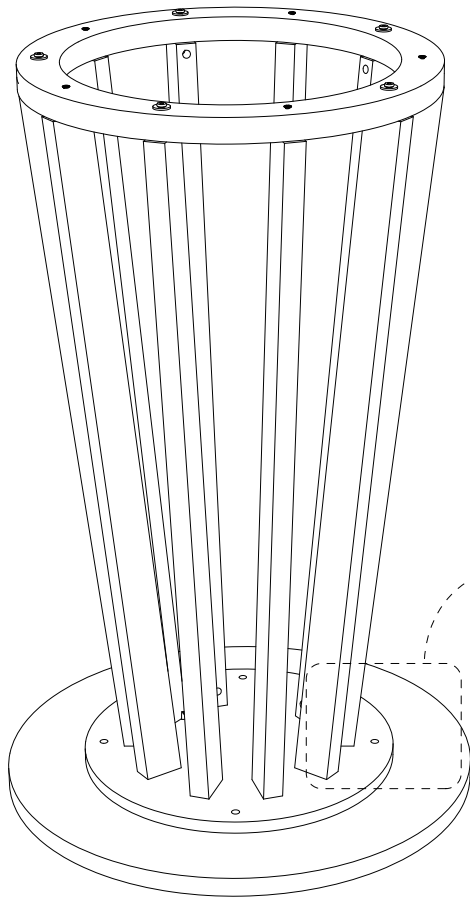

6

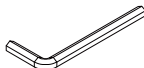
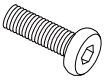

B	D	F
		
4pcs	1pc	M6x30mm 4pcs

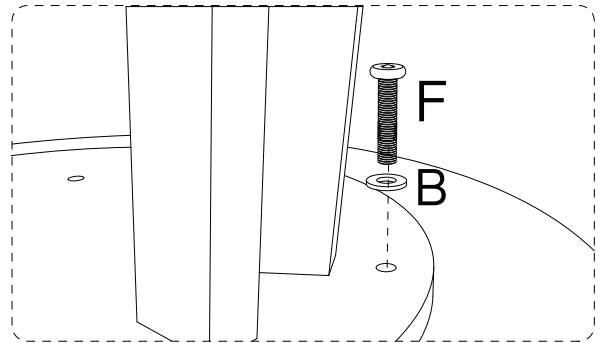

7

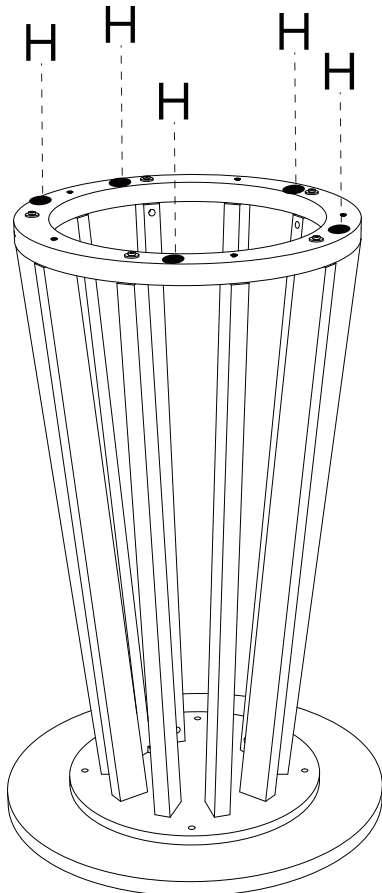

H

5pcs

Thank you for your support!

