

# Multifunctional storage

## Assembly Instructions

we recommend using the included manual installation tool for assembly.  
If you choose to use a power drill, please set it to the lowest torque setting  
to prevent over-tightening, which may damage the wooden panels.

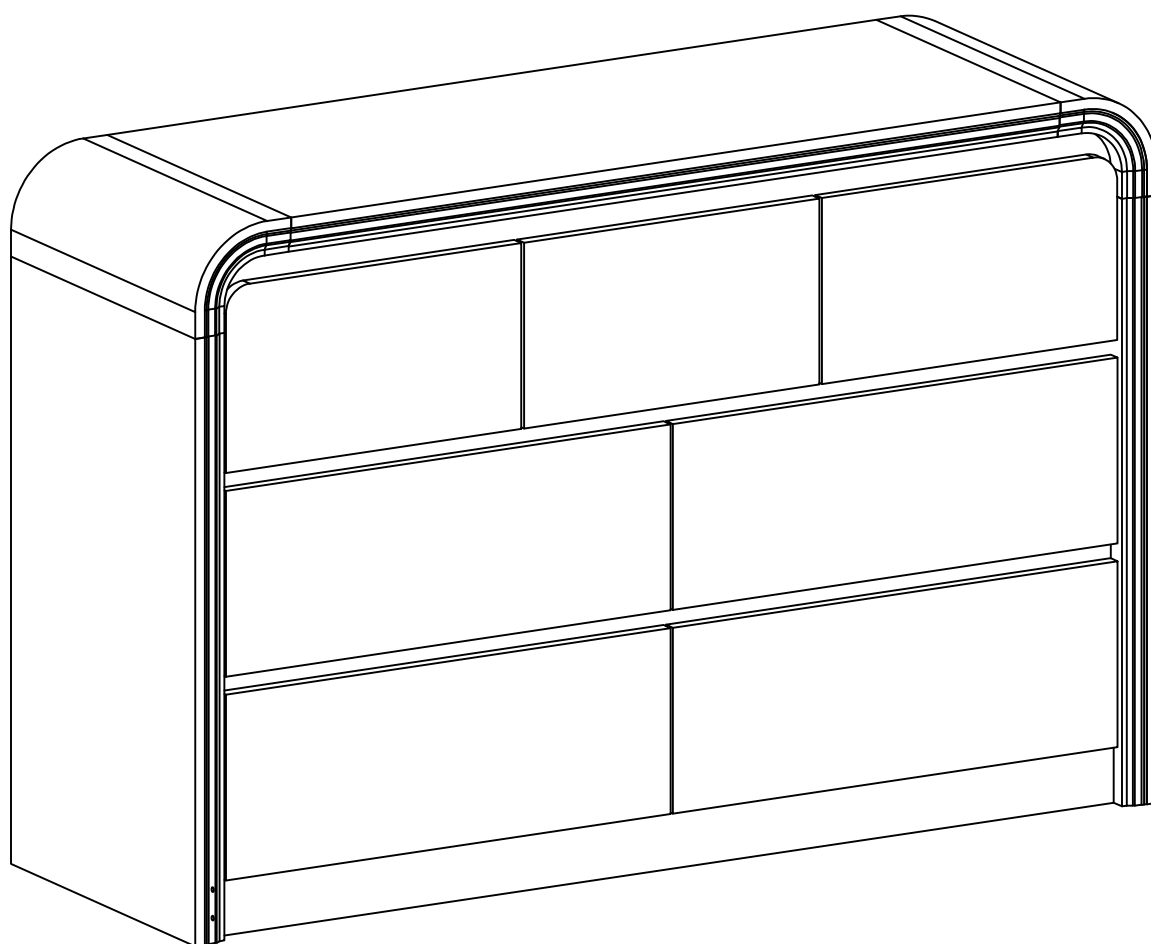

# Parts List

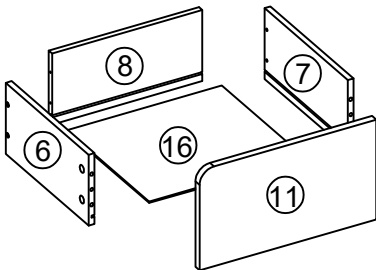
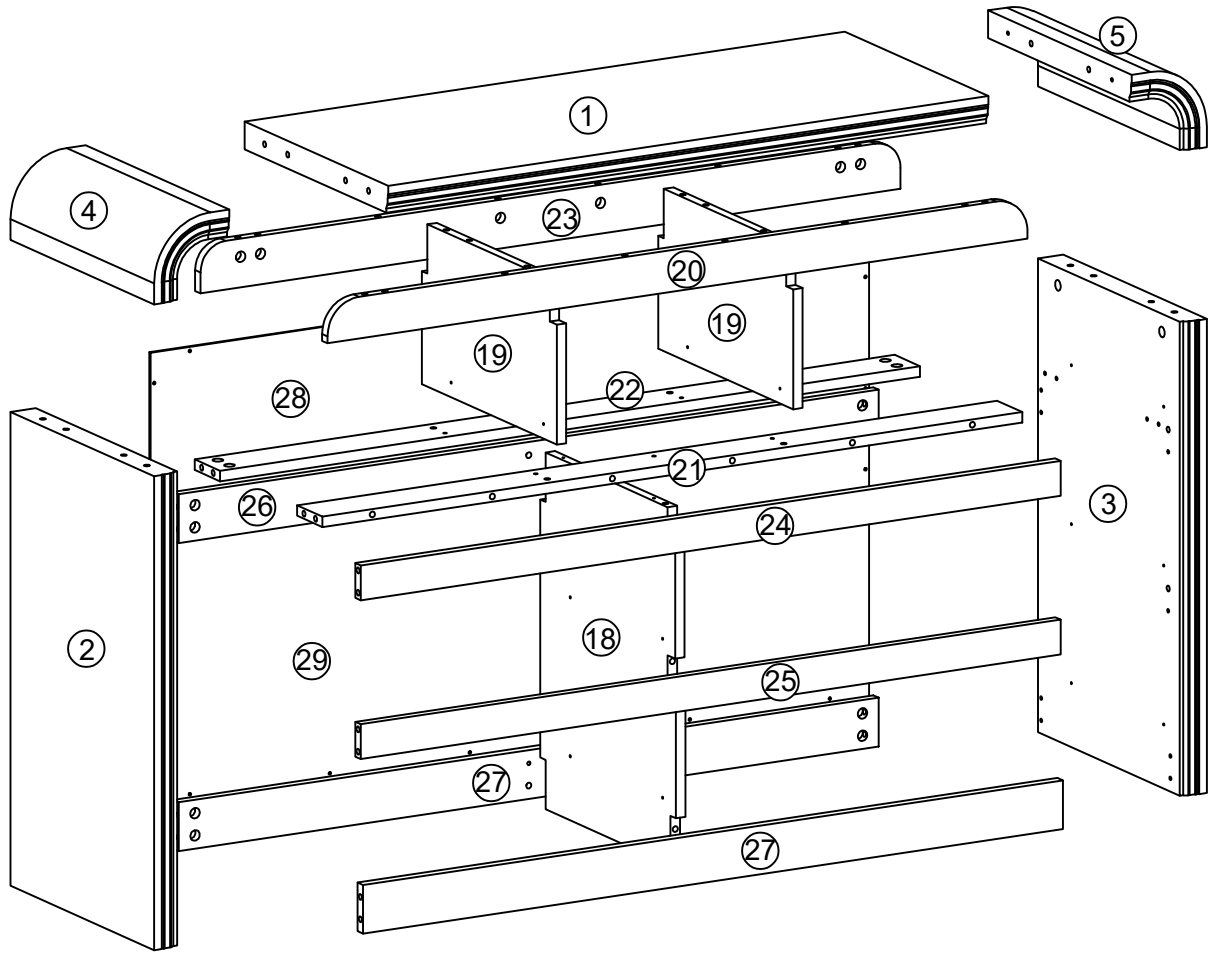

X1

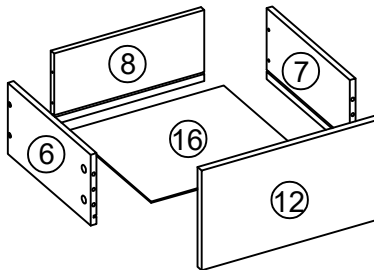

X1

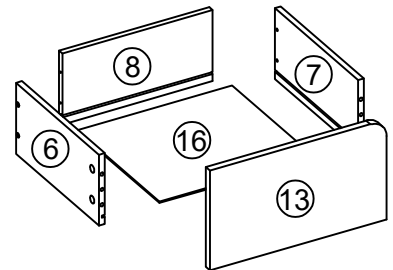

X1

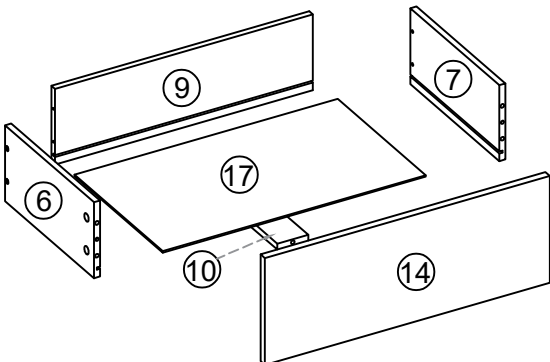

X2

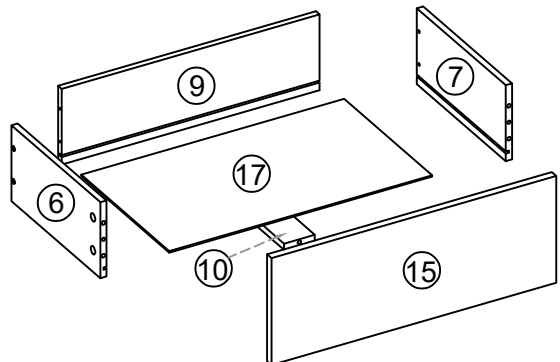

X2

# Hardware

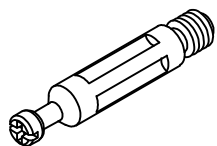

A x 89sets

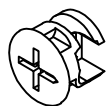

∅15X9.5MM

B x 89sets

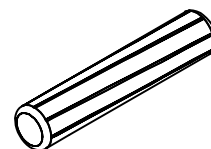

∅8 x 30MM

C x 33pcs

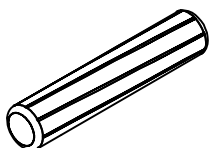

∅6 x 30MM

D x 16pcs

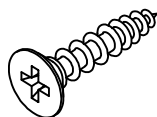

3.5 x 12MM

E x 58pcs

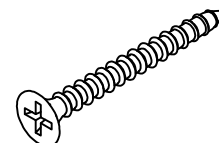

3.5 x 35MM

F x43pcs

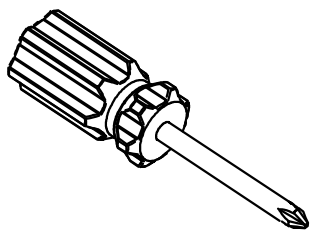

G x 1sets

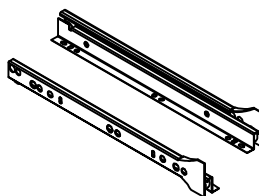

300MM

H x 7sets

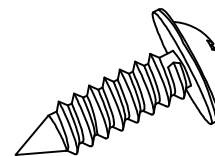



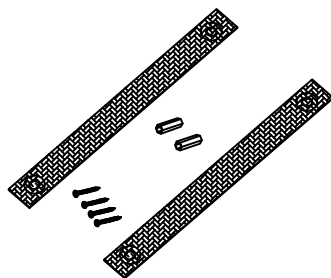

3.5 x 12MM

I x34pcs



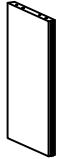

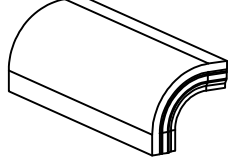
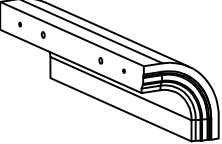
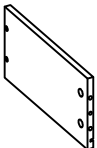
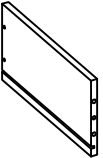

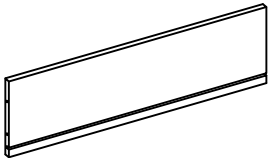
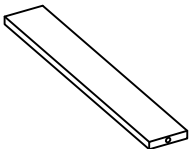
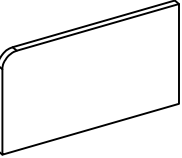
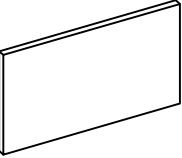
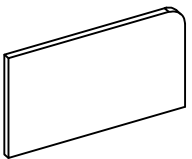
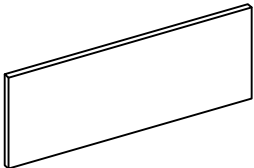
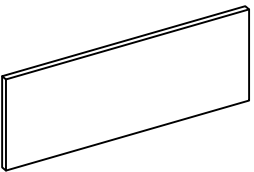
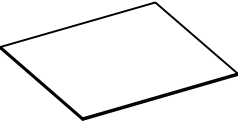

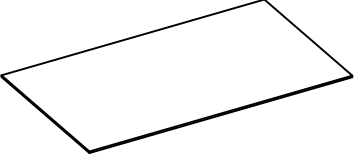
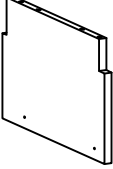

J x 1sets

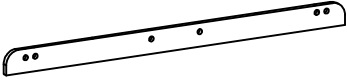
## ASSEMBLY MATERIAL

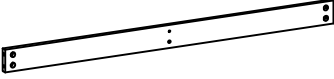
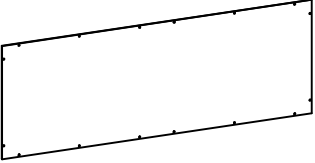
| Item no. | Reference Image   | Qty. | Item no. | Reference Image   | Qty. |
|----------|---|------|----------|---|------|
| ①        |    | X1   | ②        |    | X1   |
| ③        |    | X1   | ④        |    | X1   |
| ⑤        |   | X1   | ⑥        |   | X7   |
| ⑦        |  | X7   | ⑧        |  | X3   |
| ⑨        |  | X4   | ⑩        |  | X4   |
| ⑪        |  | X1   | ⑫        |  | X1   |
| ⑬        |  | X2   | ⑭        |  | X2   |
| ⑮        |  | X2   | ⑯        |  | X3   |

## ASSEMBLY MATERIAL

| Item no. | Reference Image   | Oty. |
|----------|---|------|
| 17       |    | X4   |
| 19       |    | X2   |
| 21       |    | X1   |
| 23       |  | X1   |
| 25       |  | X1   |
| 27       |  | X2   |
| 29       |  | X1   |
|          |   |      |

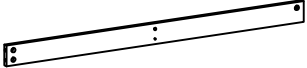
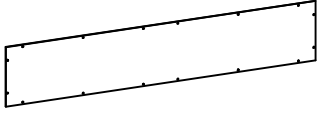
| Item no. | Reference Image   | Oty. |
|----------|---|------|
| 18       |    | X1   |
| 20       |     | X1   |
| 22       |     | X1   |
| 24       |  | X1   |
| 26       |  | X1   |
| 28       |  | X1   |
|          |   |      |

# Step 1

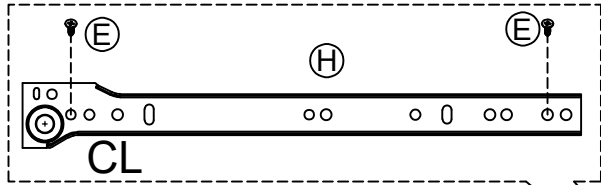
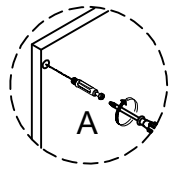
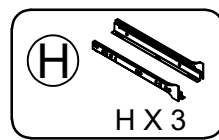
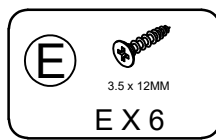
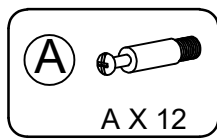

Install first rail on the left side of board.

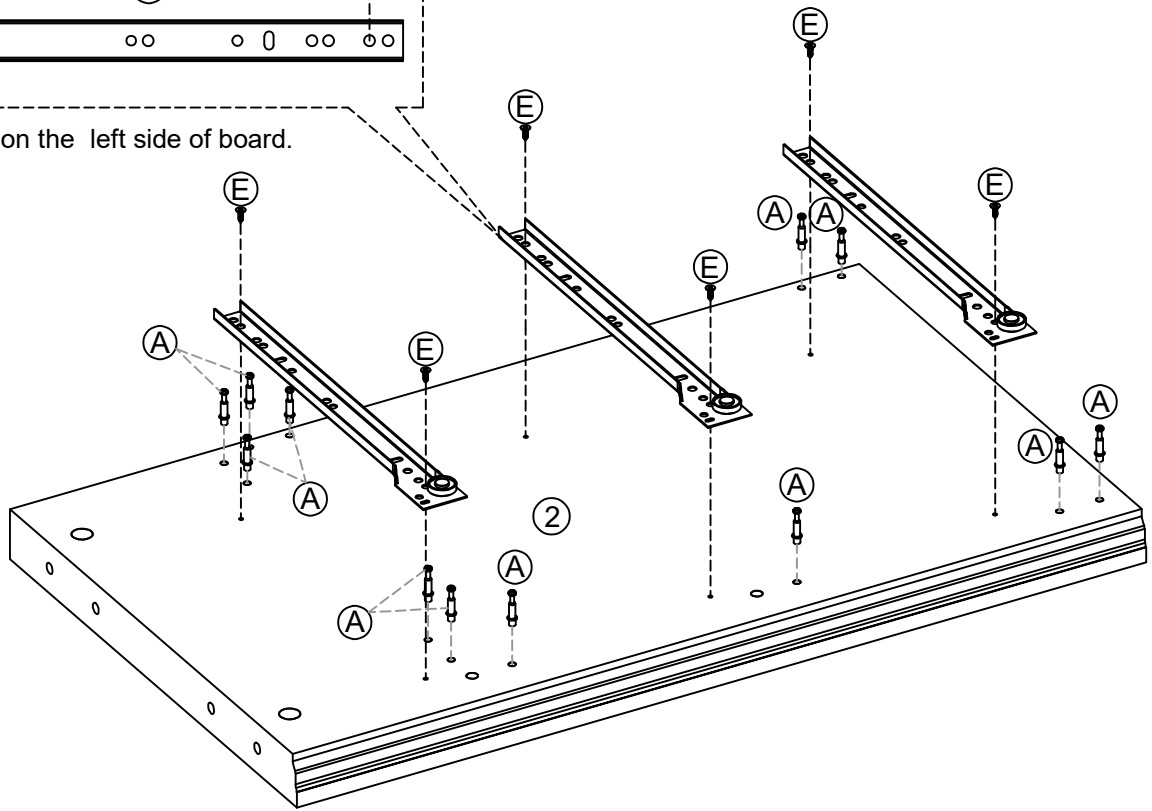

# Step 2

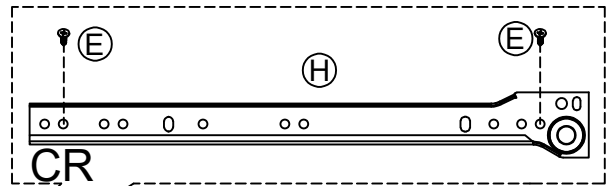
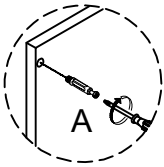
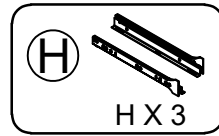
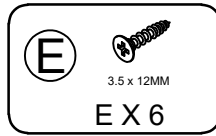
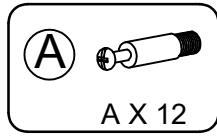

Install first rail on the right side of board.

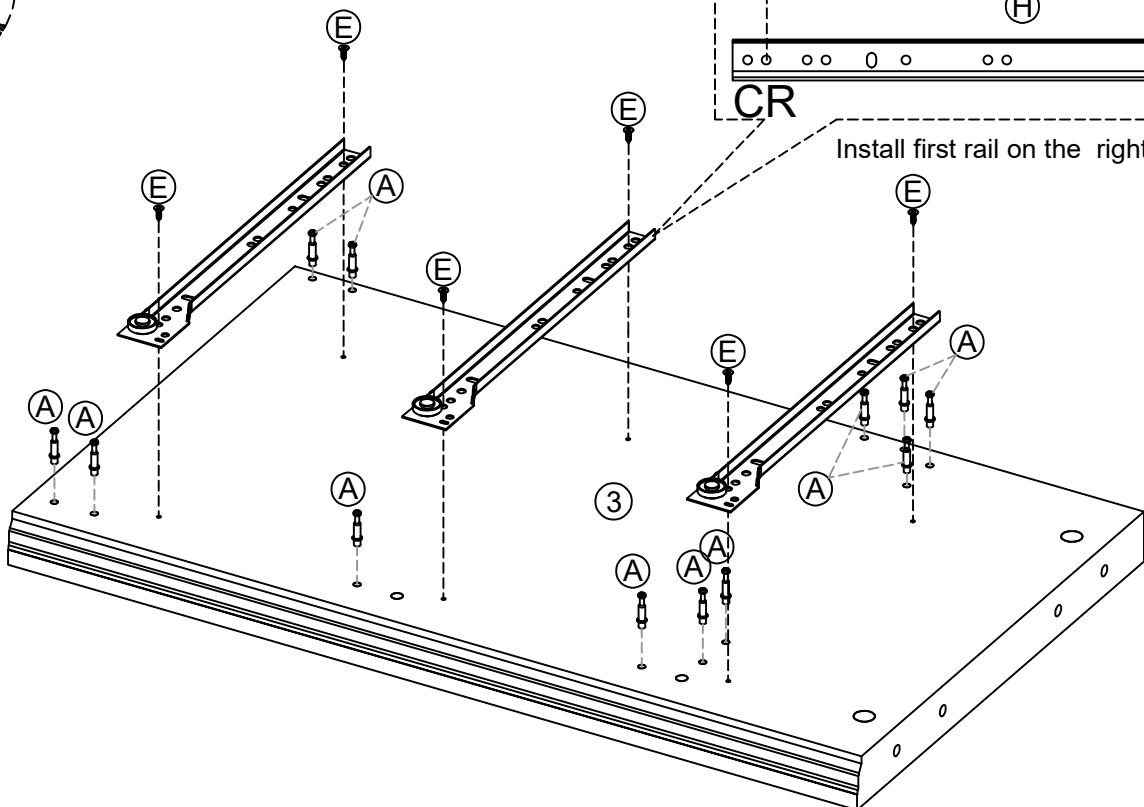

# Step 3

**E**   
3.5 x 12MM  
**E x 8**

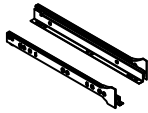
**H**   
**HX2**

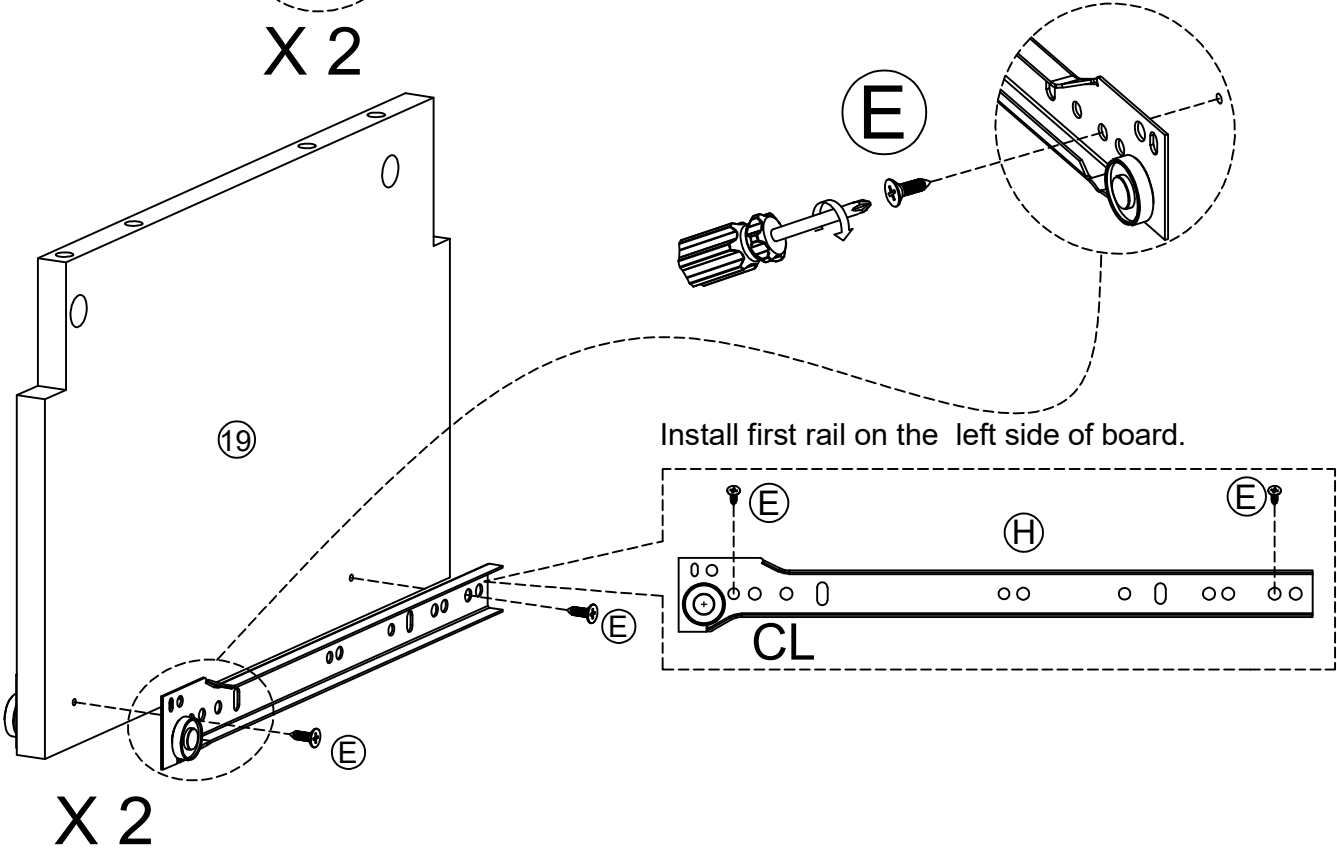
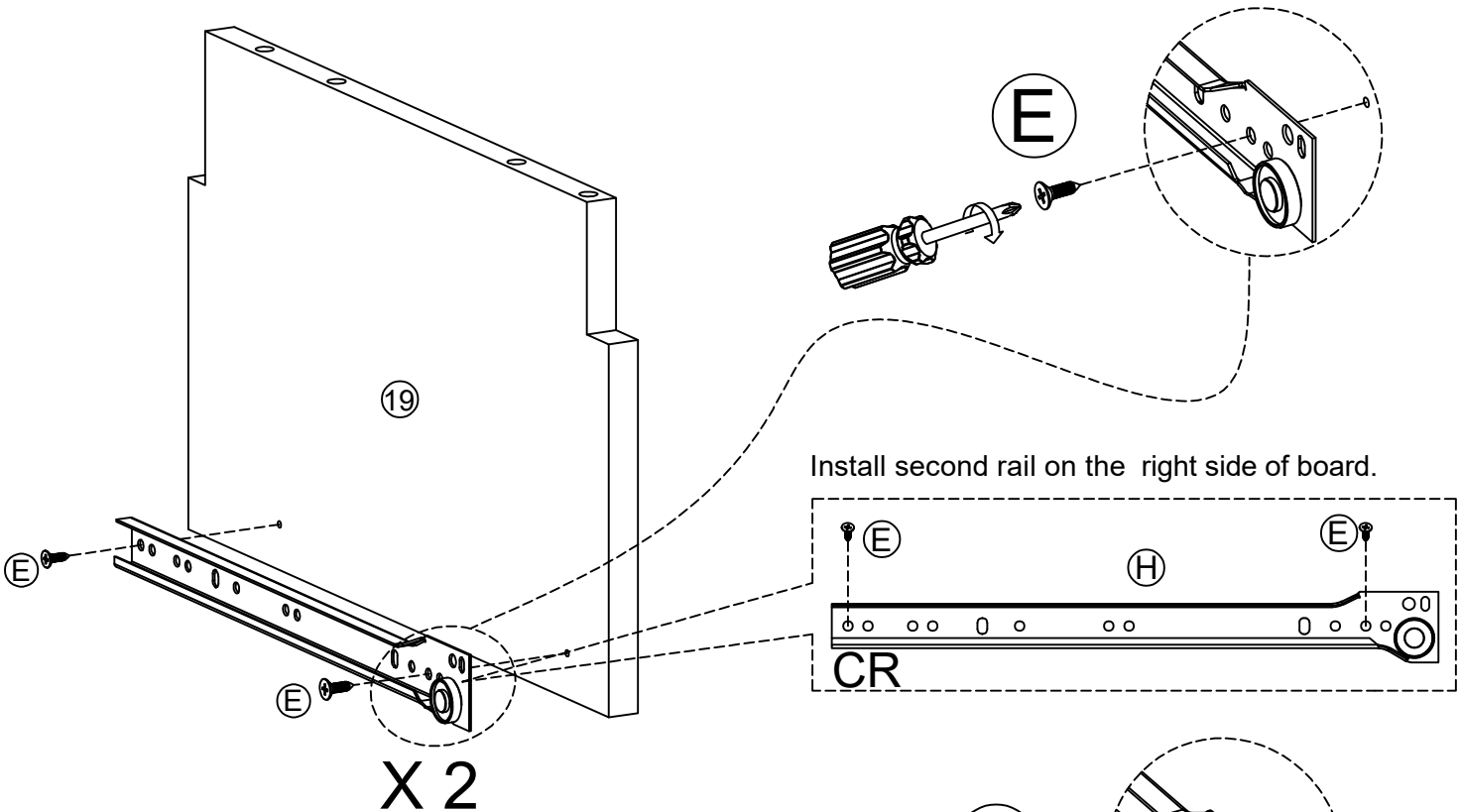

**NOTICE:** To ensure the stability of the structure, please pay attention to the hole position when locking screws. CL side should lock on the first hole position near the pulley, CR side lock on the second hole position near the pulley.

# Step 4

**E**   
3.5 x 12MM  
**E x 8**

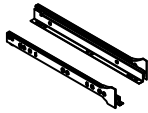
**H**   
**HX2**

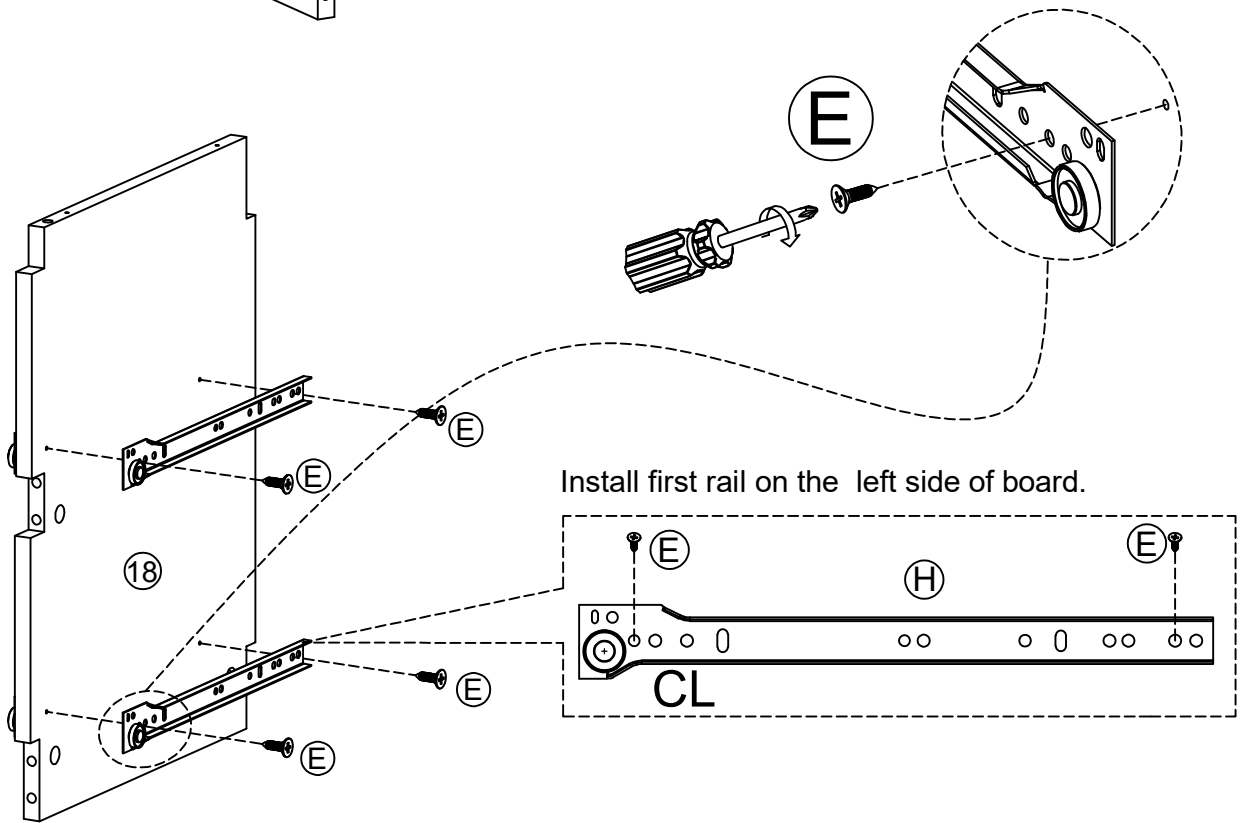
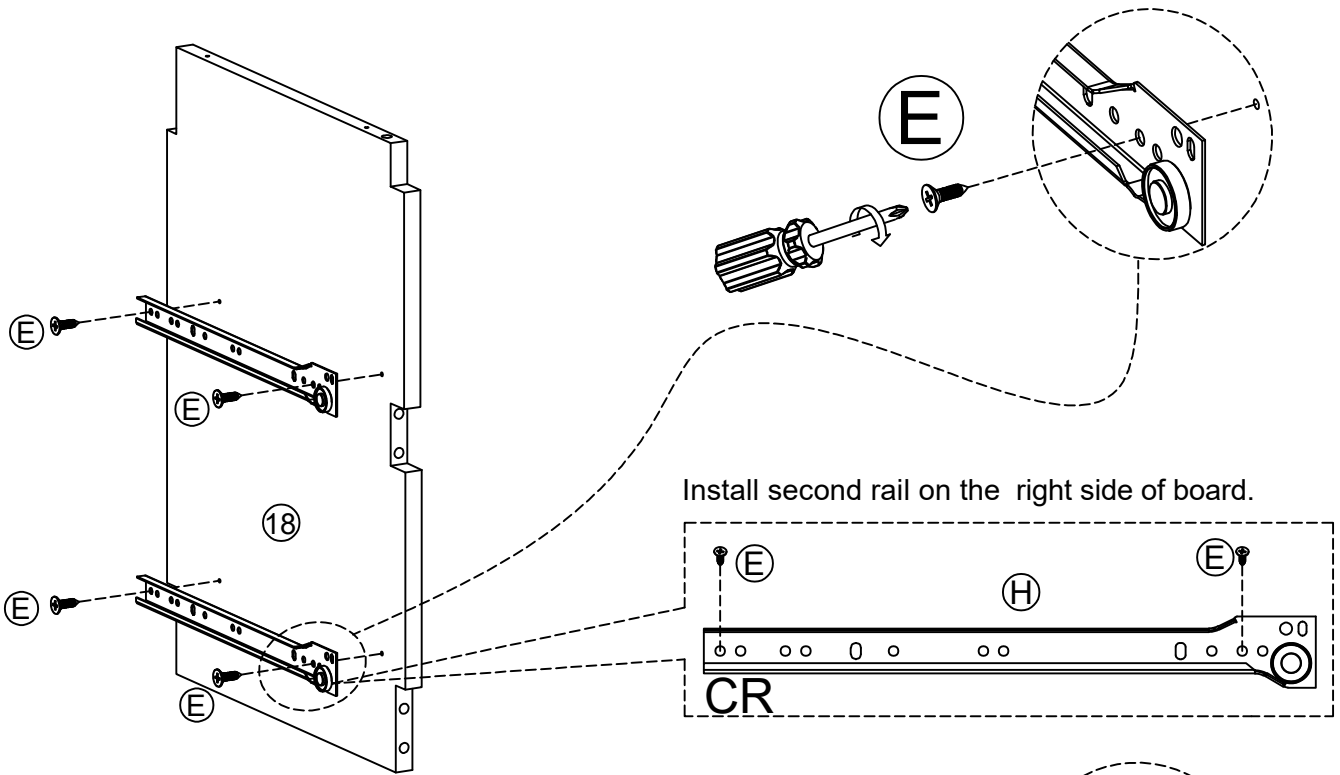

**NOTICE:** To ensure the stability of the structure, please pay attention to the hole position when locking screws. CL side should lock on the first hole position near the pulley, CR side lock on the second hole position near the pulley.

# Step 5

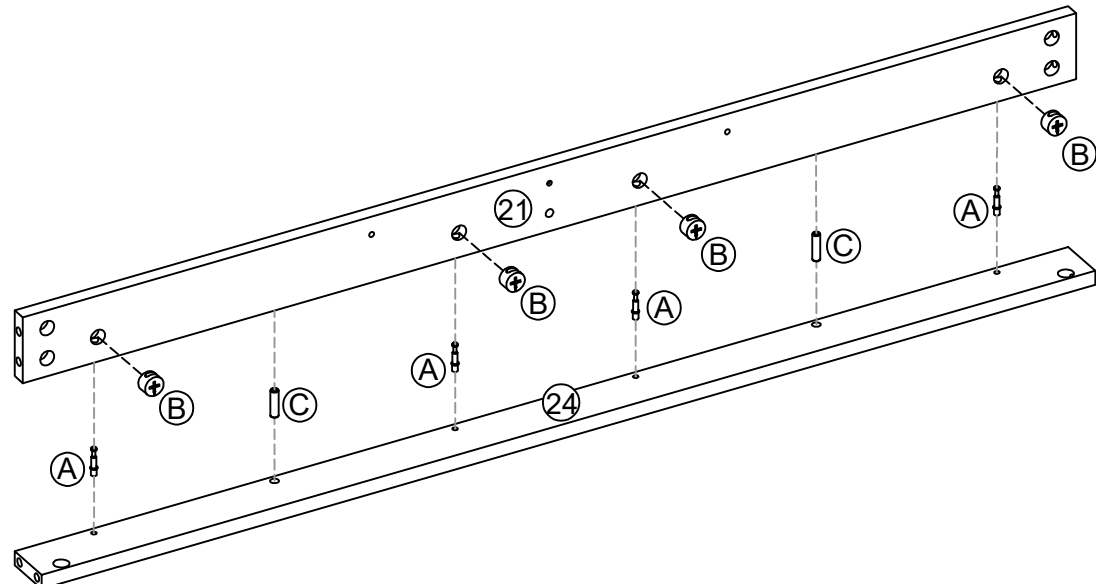
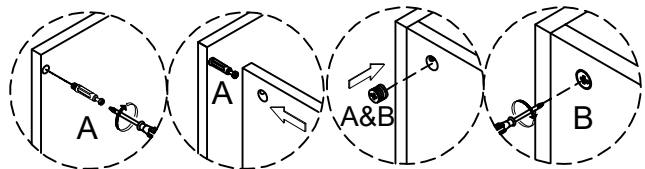
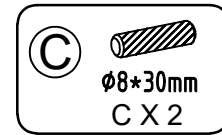
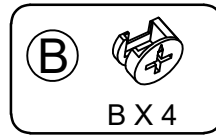
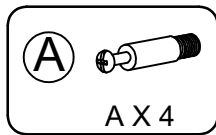

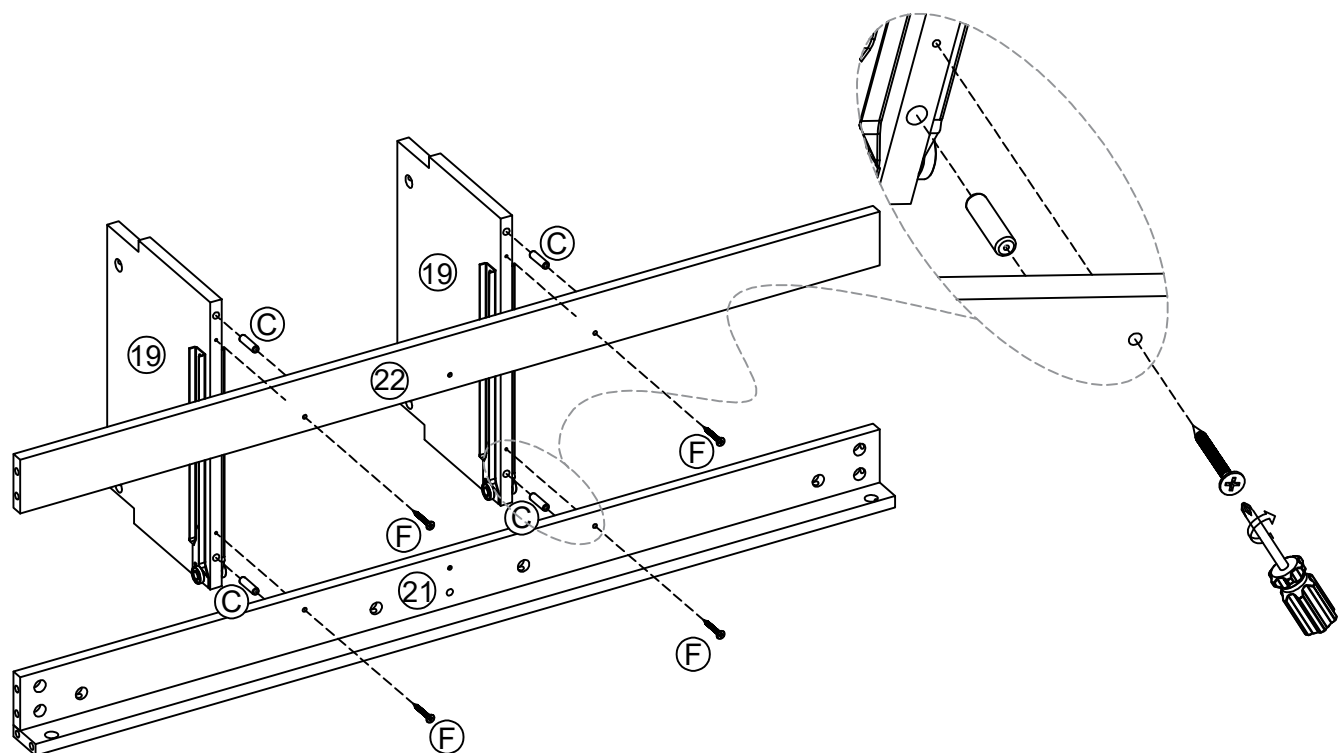
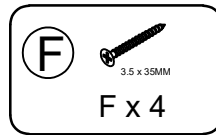
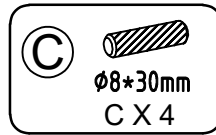

# Step 6



# Step 7

**A**  AX 3

**B**  BX 3

**C**  Ø8\*30mm  
CX 4

**F**  3.5 x 35MM  
Fx 1

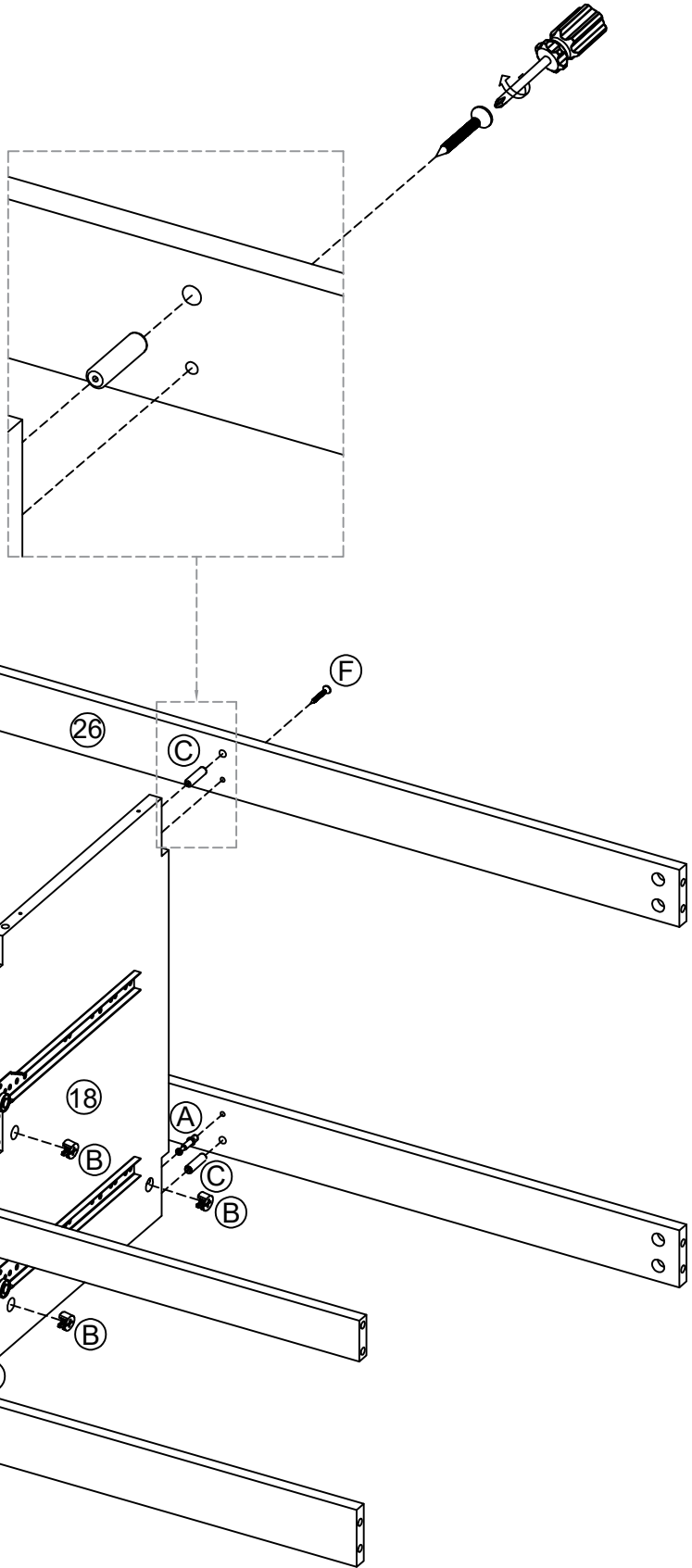
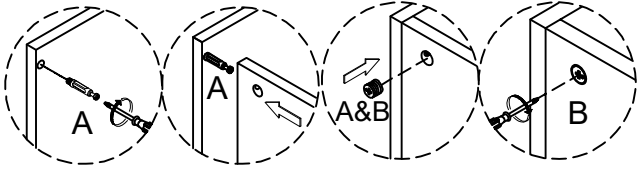

# Step 8

(C)   
Ø8\*30mm  
C X 1

(F)   
3.5 x 35MM  
F x 2

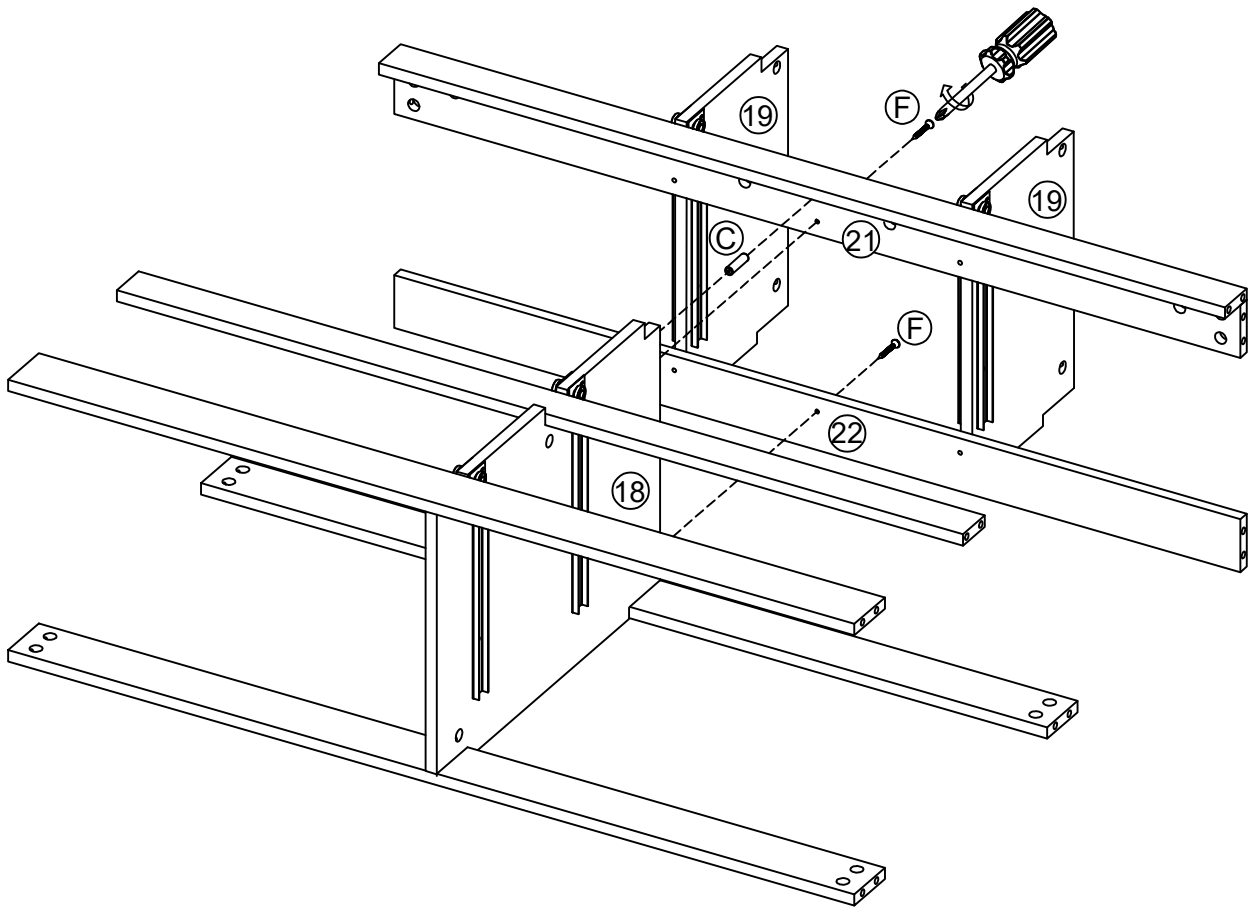

# Step 9

**(B)**  B X 12

**(C)**   $\phi 8 \times 30 \text{mm}$  C X 2

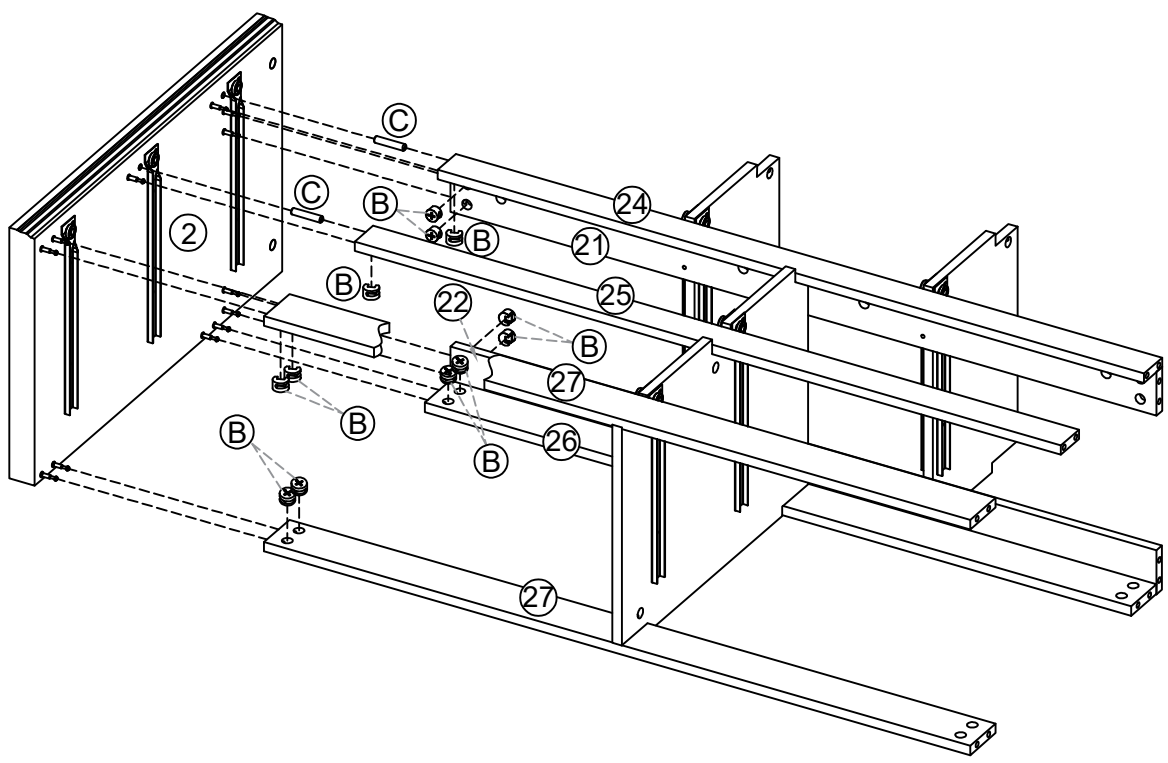
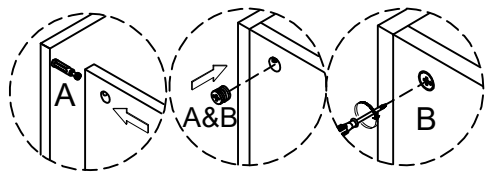

# Step 10

**(B)**  B X 12

**(C)**   $\phi 8 \times 30 \text{mm}$  C X 2

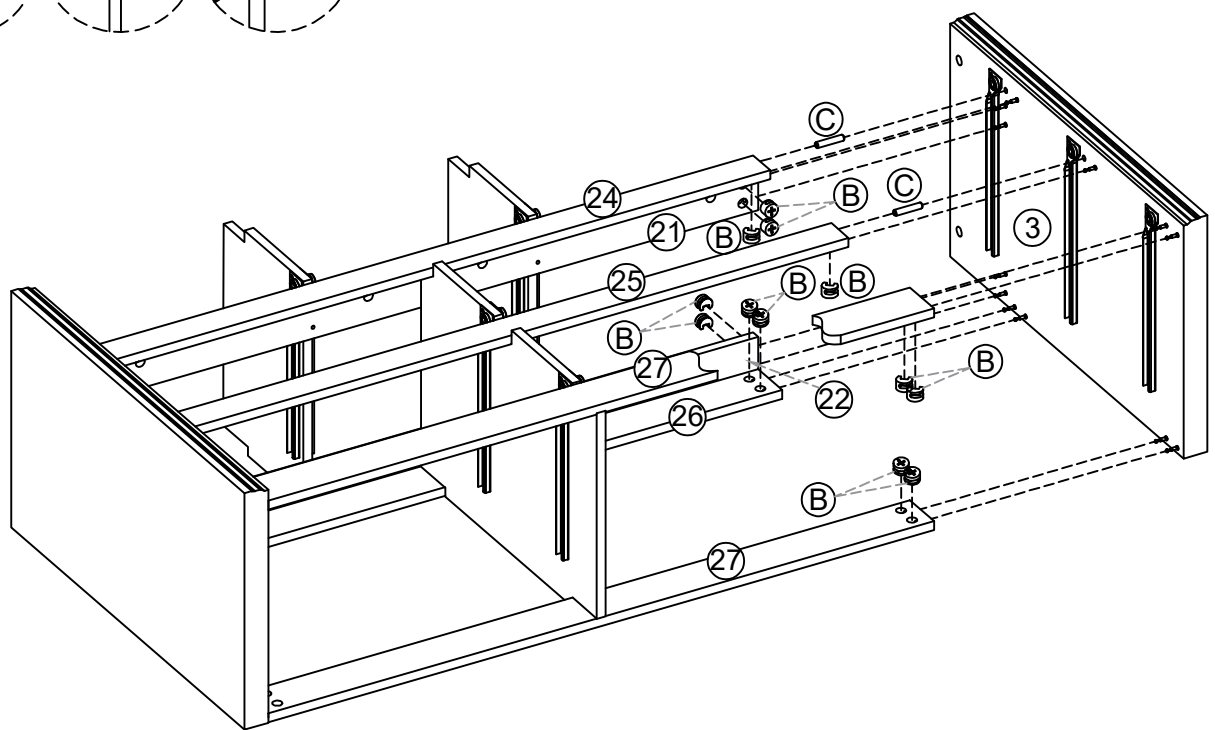
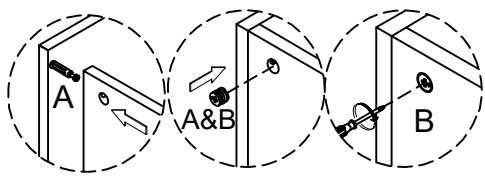

# Step 11

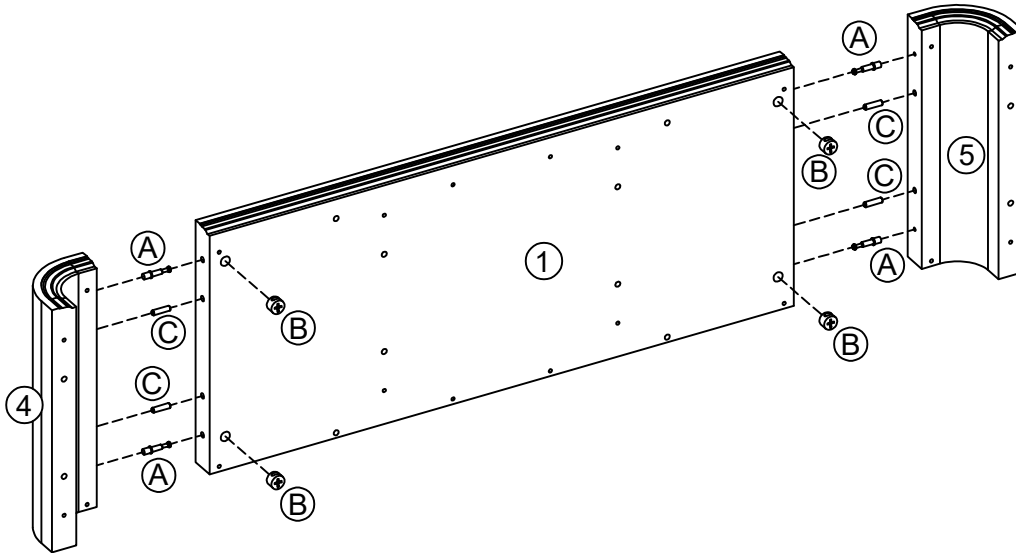
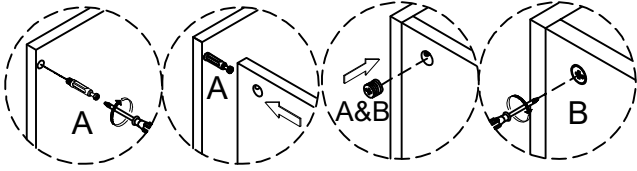
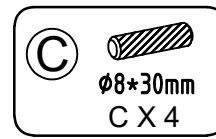
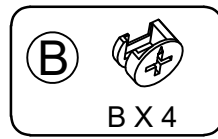
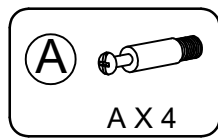

# Step 12

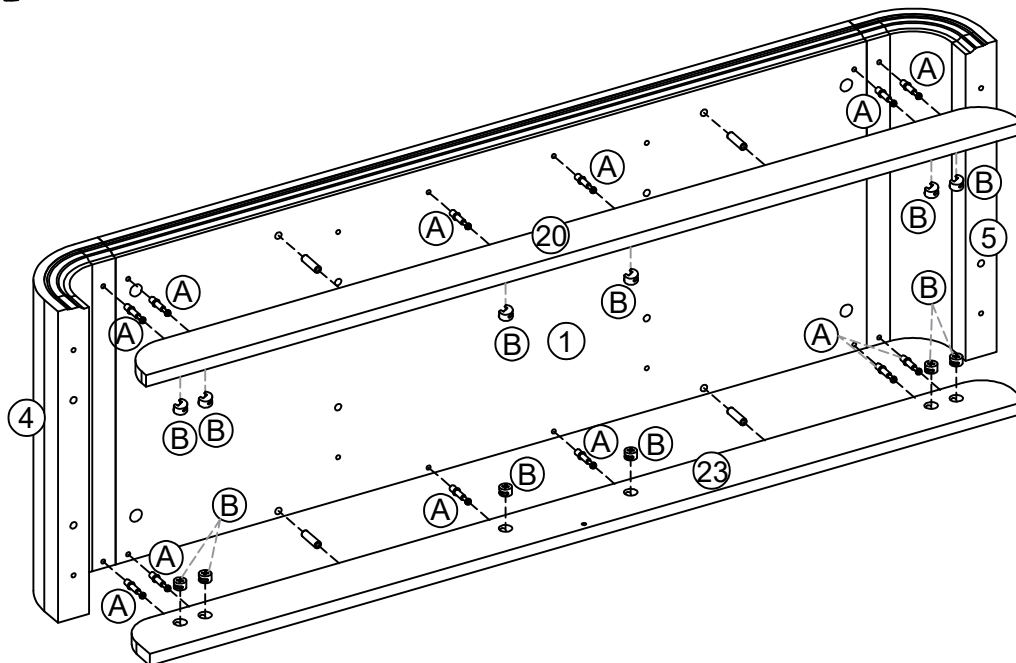
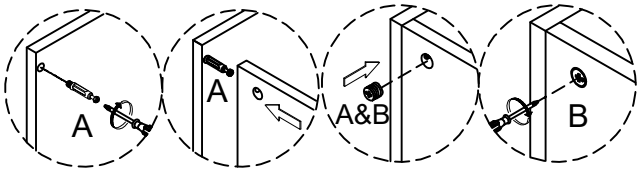
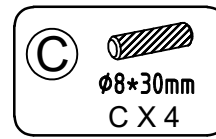
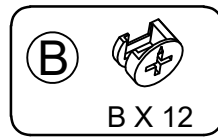
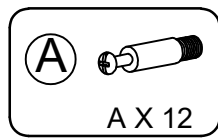



# Step 14

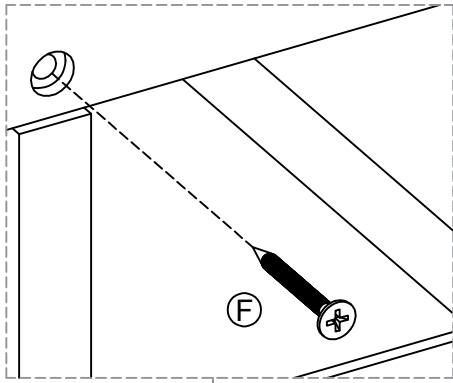
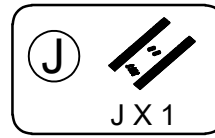
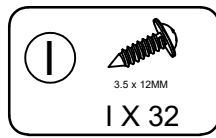
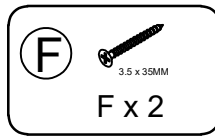

Firstly, use F to secure the No.23 piece and then secure the back plate No.28 and No.29.

As shown in the figure:

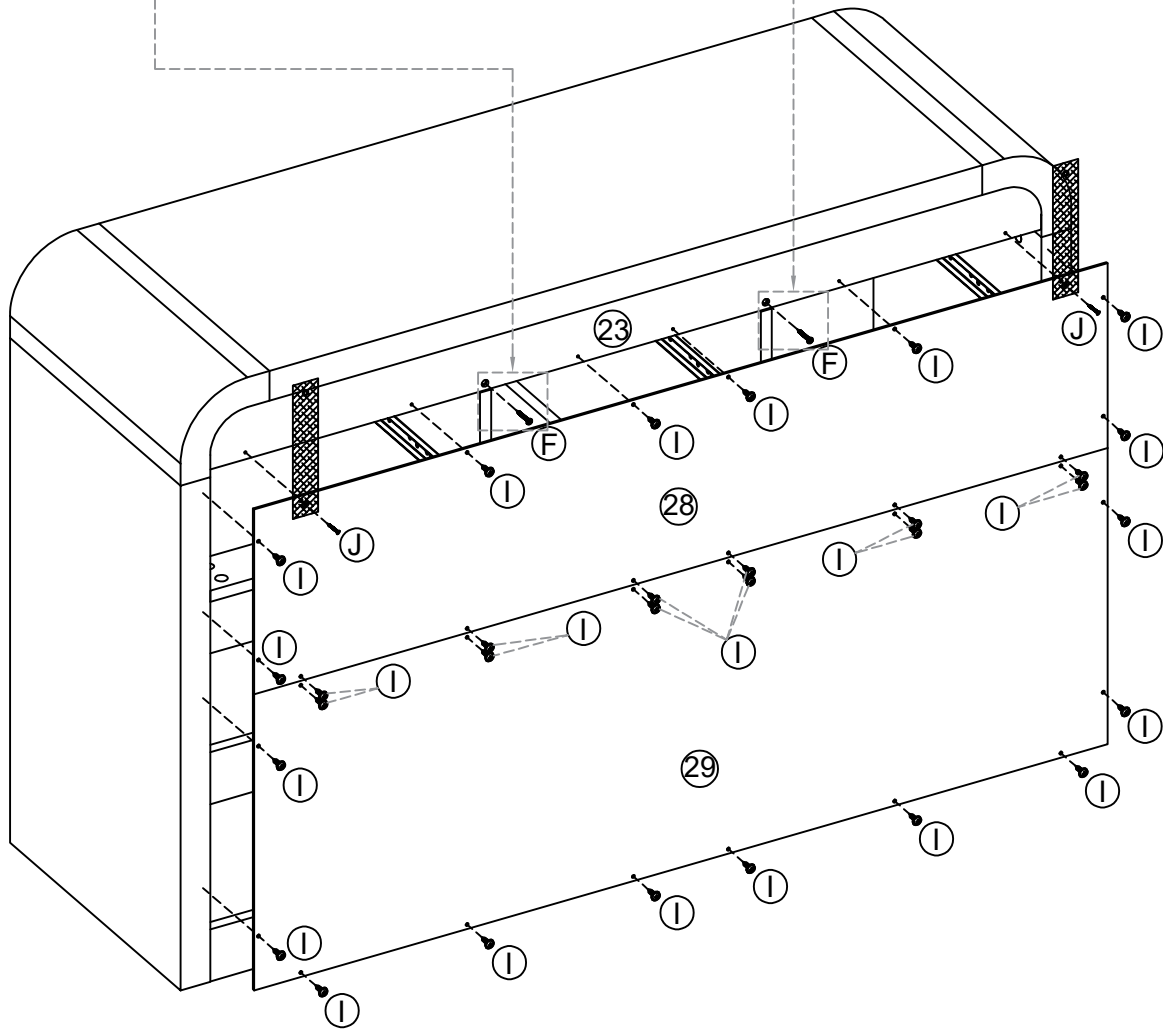

# Step 15

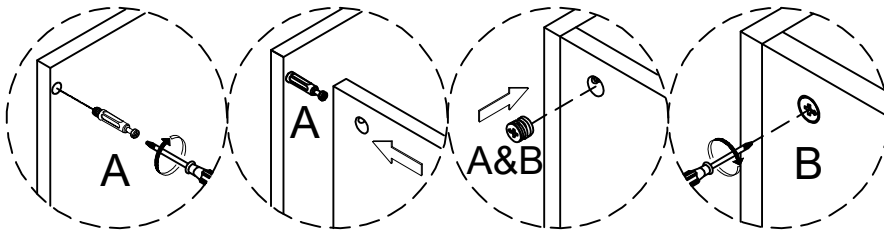
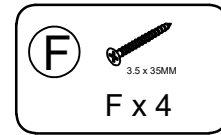
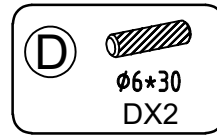
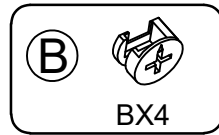
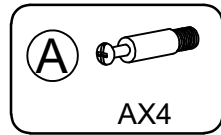

## Step:1

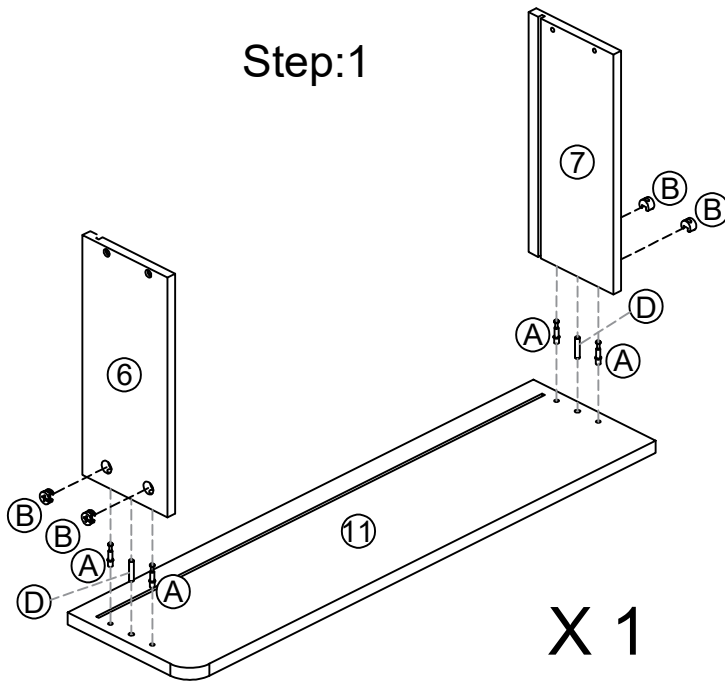

## Step:2

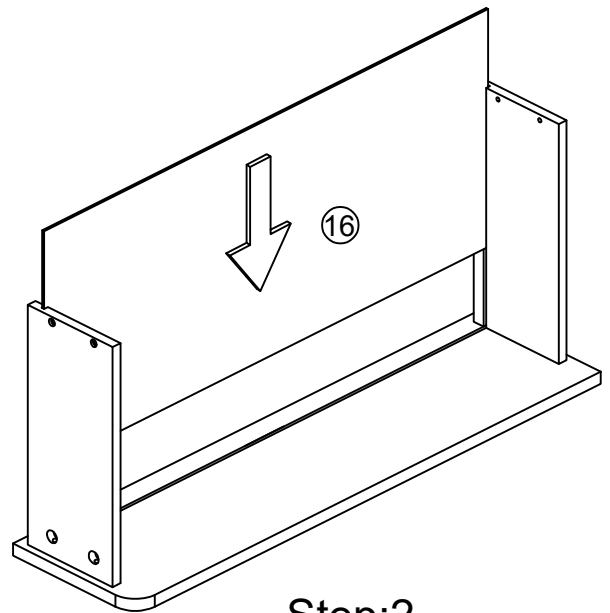

## Step:3

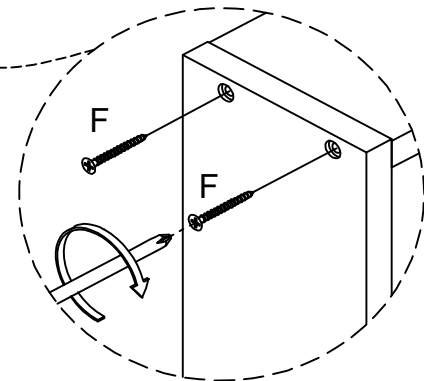
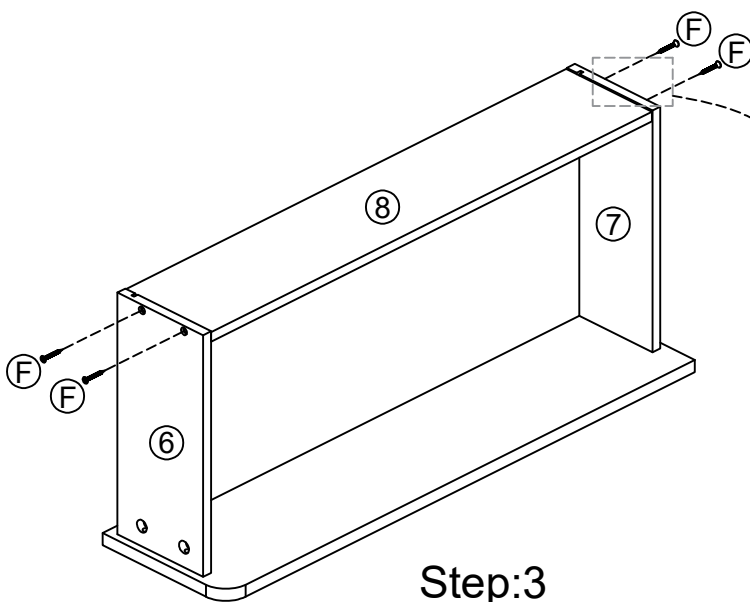

# Step 16

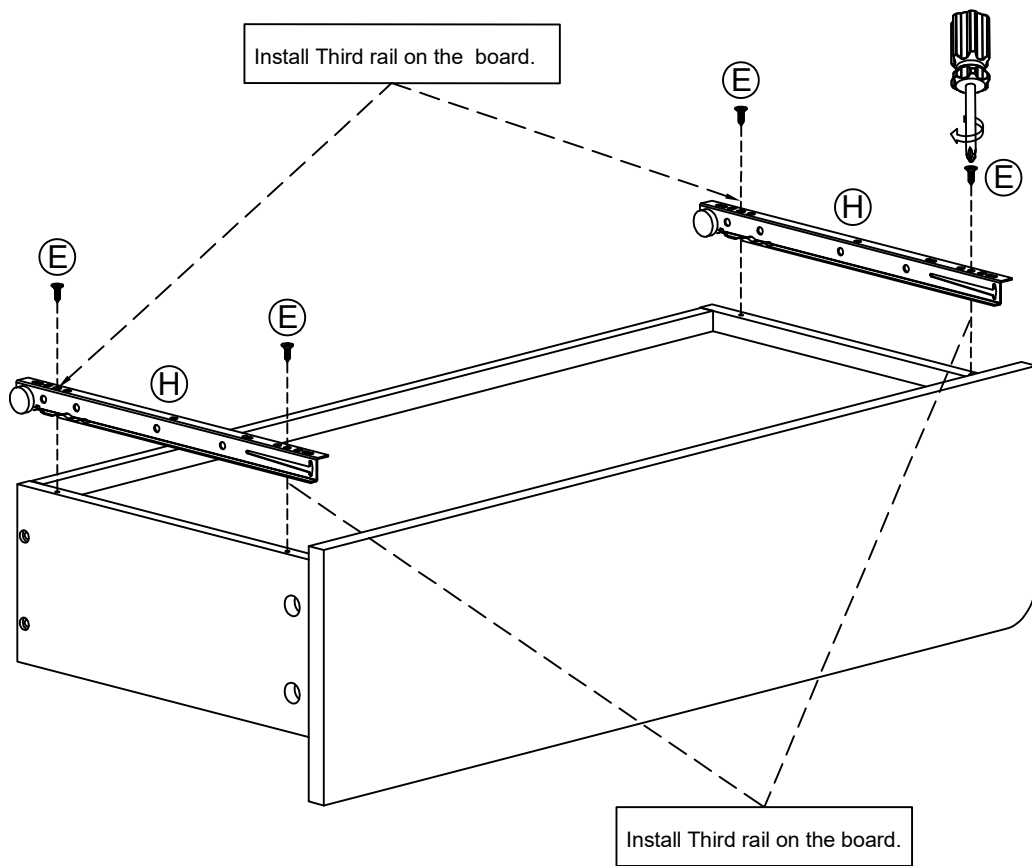
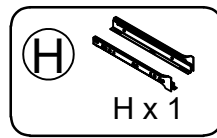
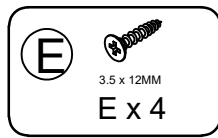

X 1

# Step 17

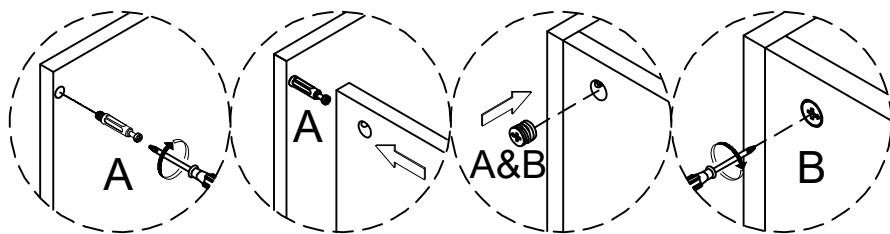
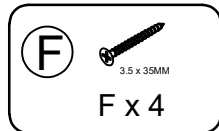
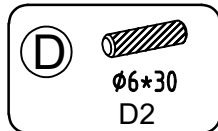
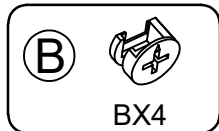
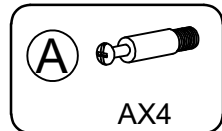

## Step:1

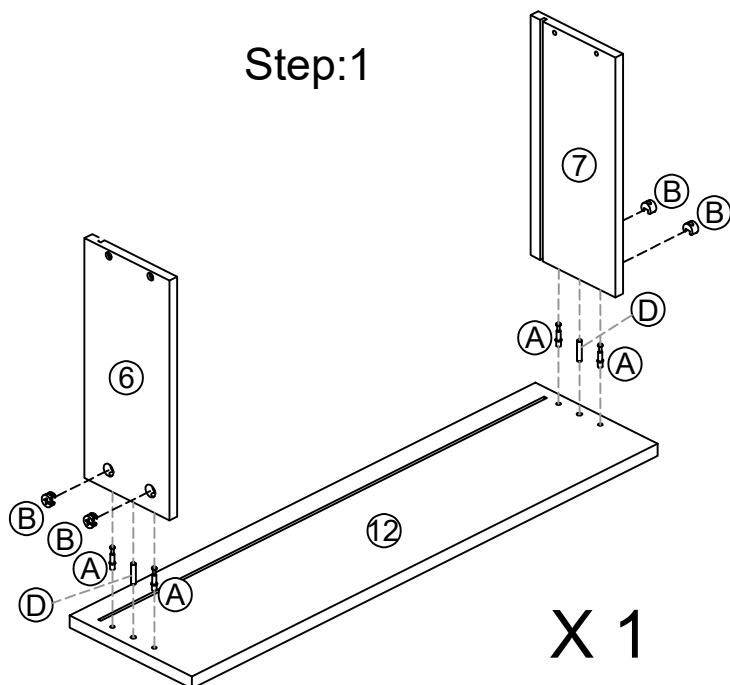

X 1

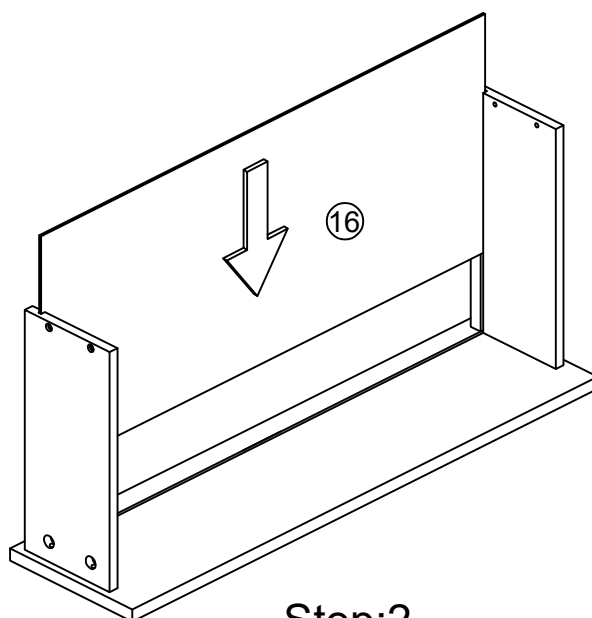

## Step:2

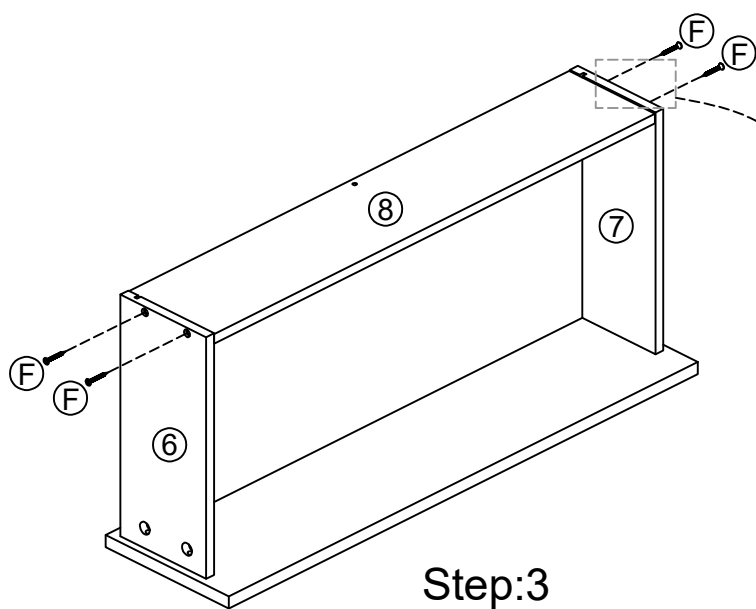

## Step:3

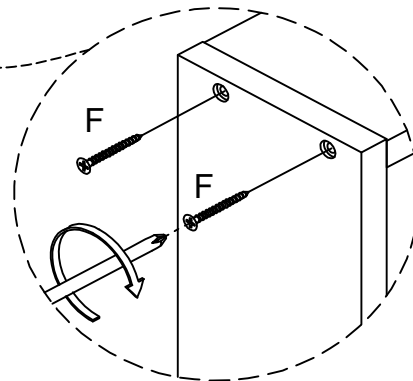

# Step 18

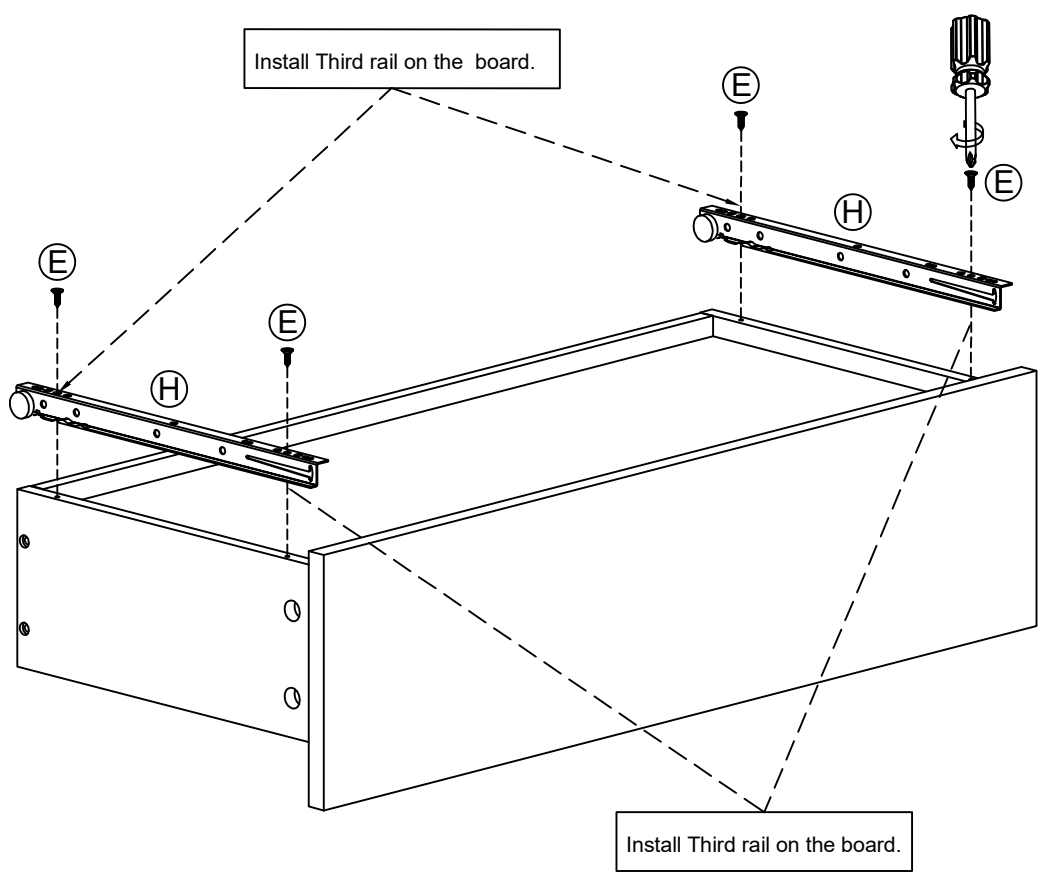
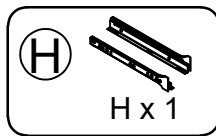
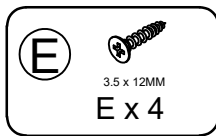

X 1

# Step 19

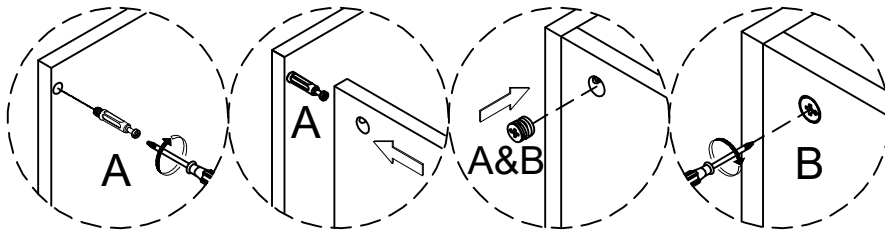
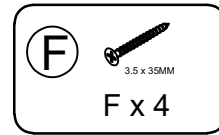
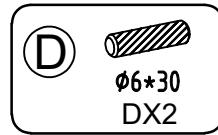
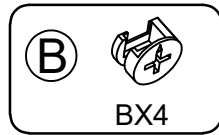
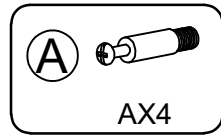

## Step:1

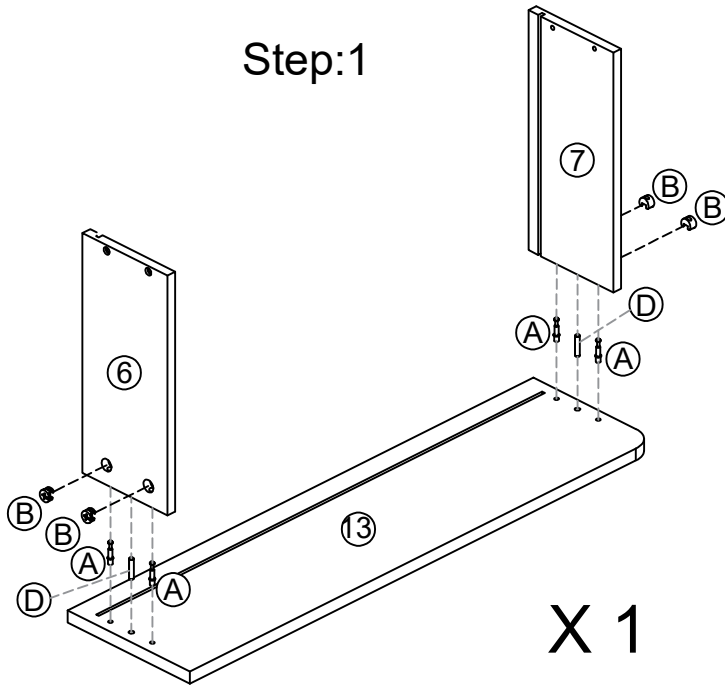

X 1

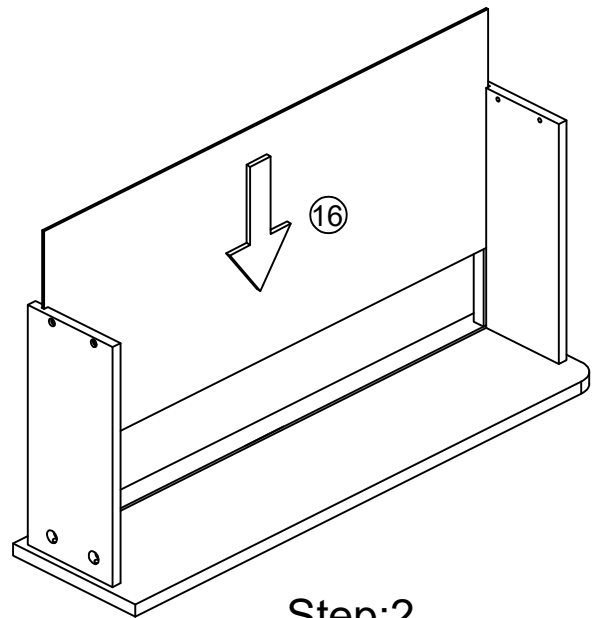

## Step:2

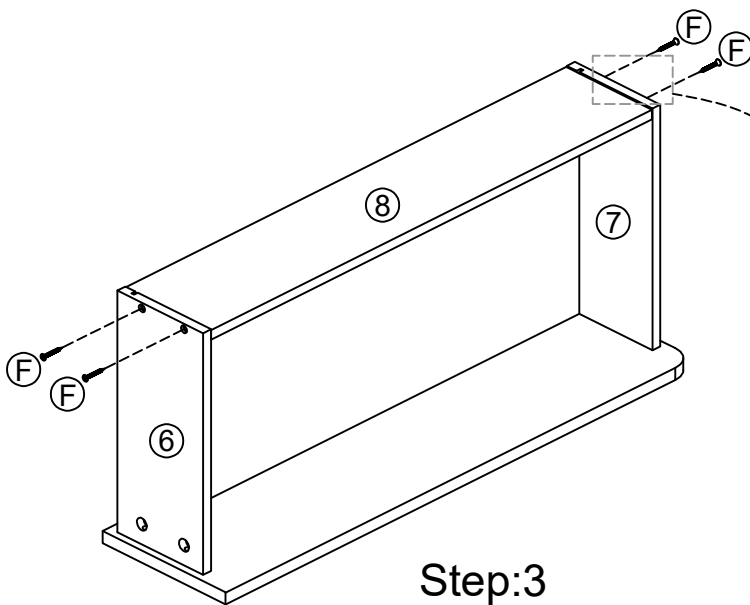

## Step:3

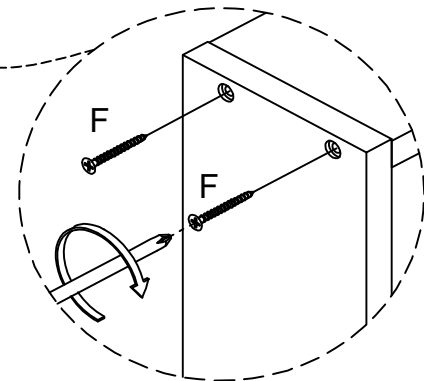

# Step 20

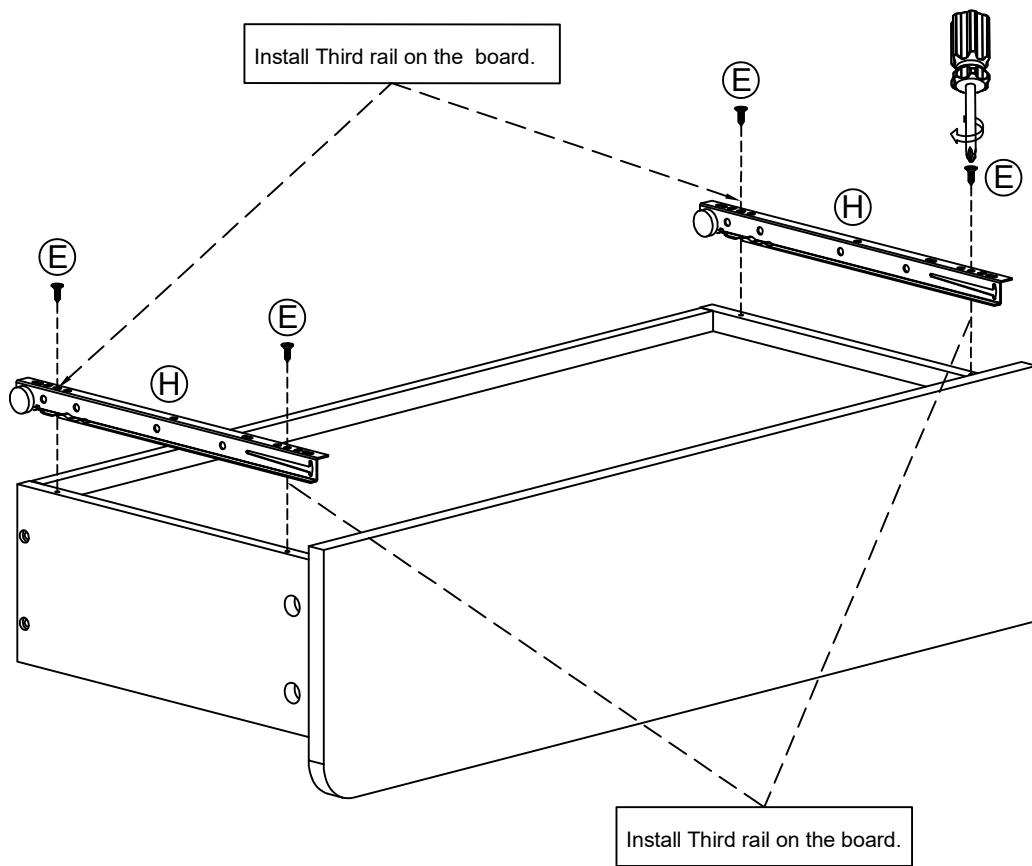
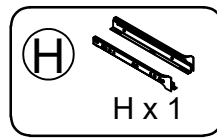
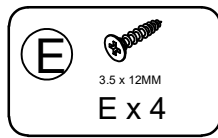

X 1

# Step 21

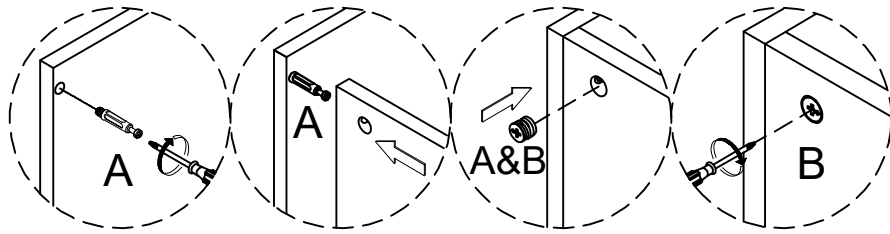
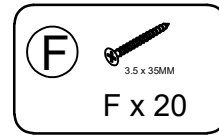
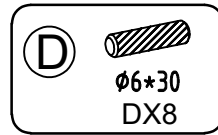
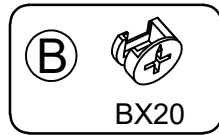
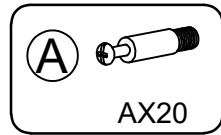

## Step:1

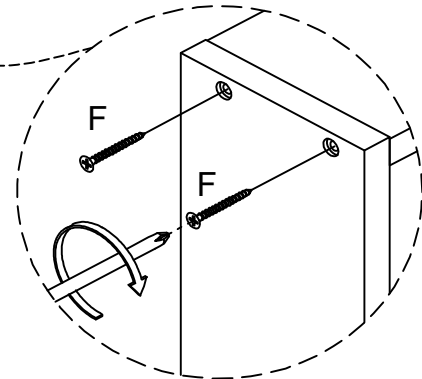
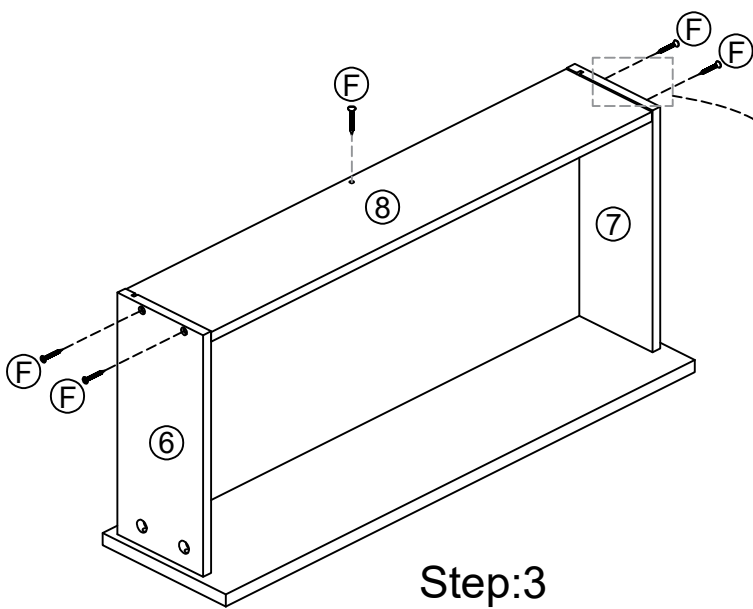
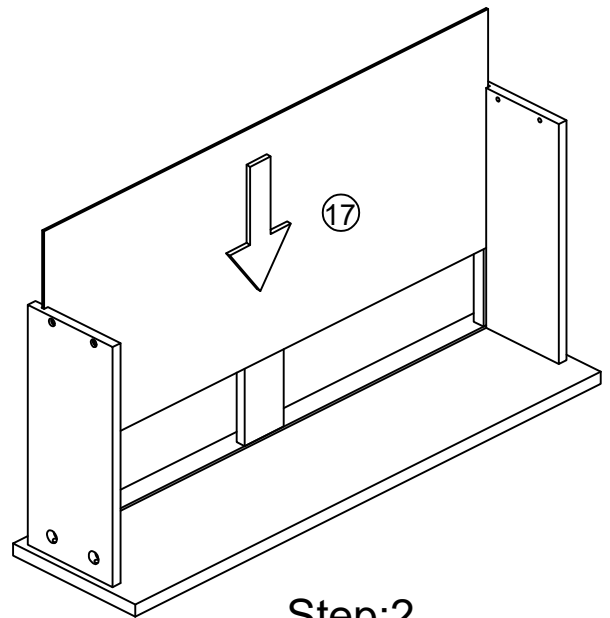
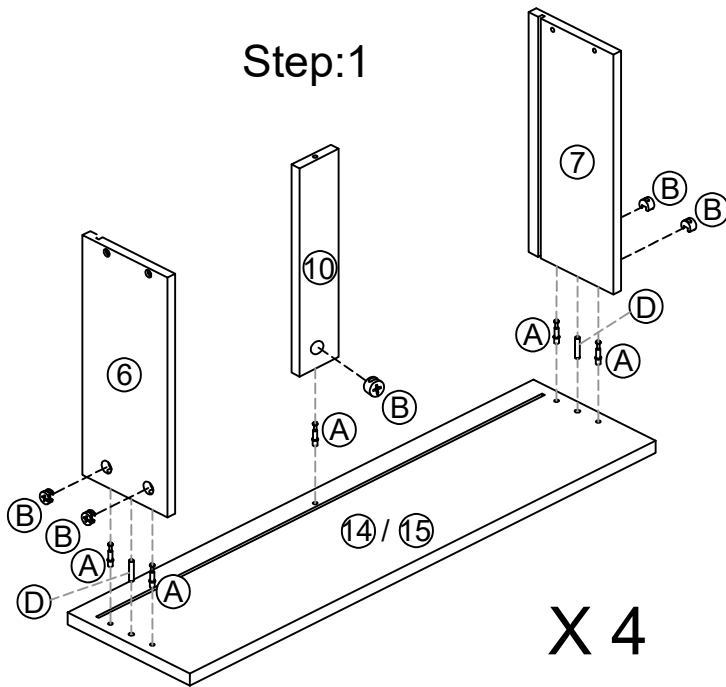

# Step 22

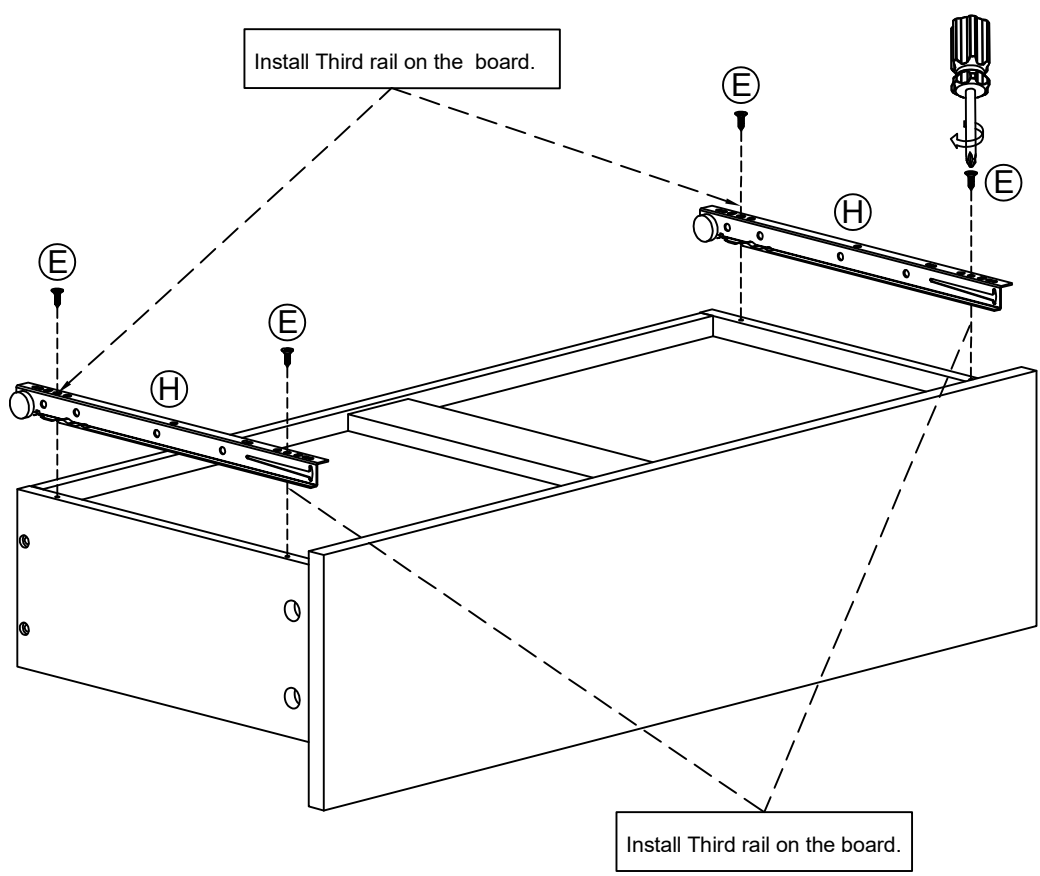
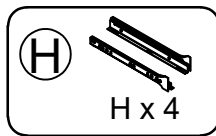
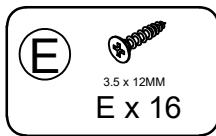

# Step 23

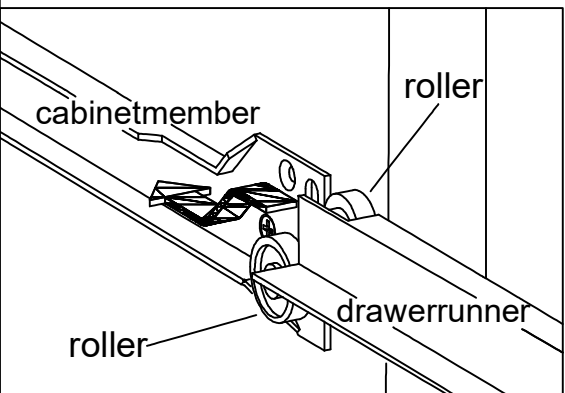
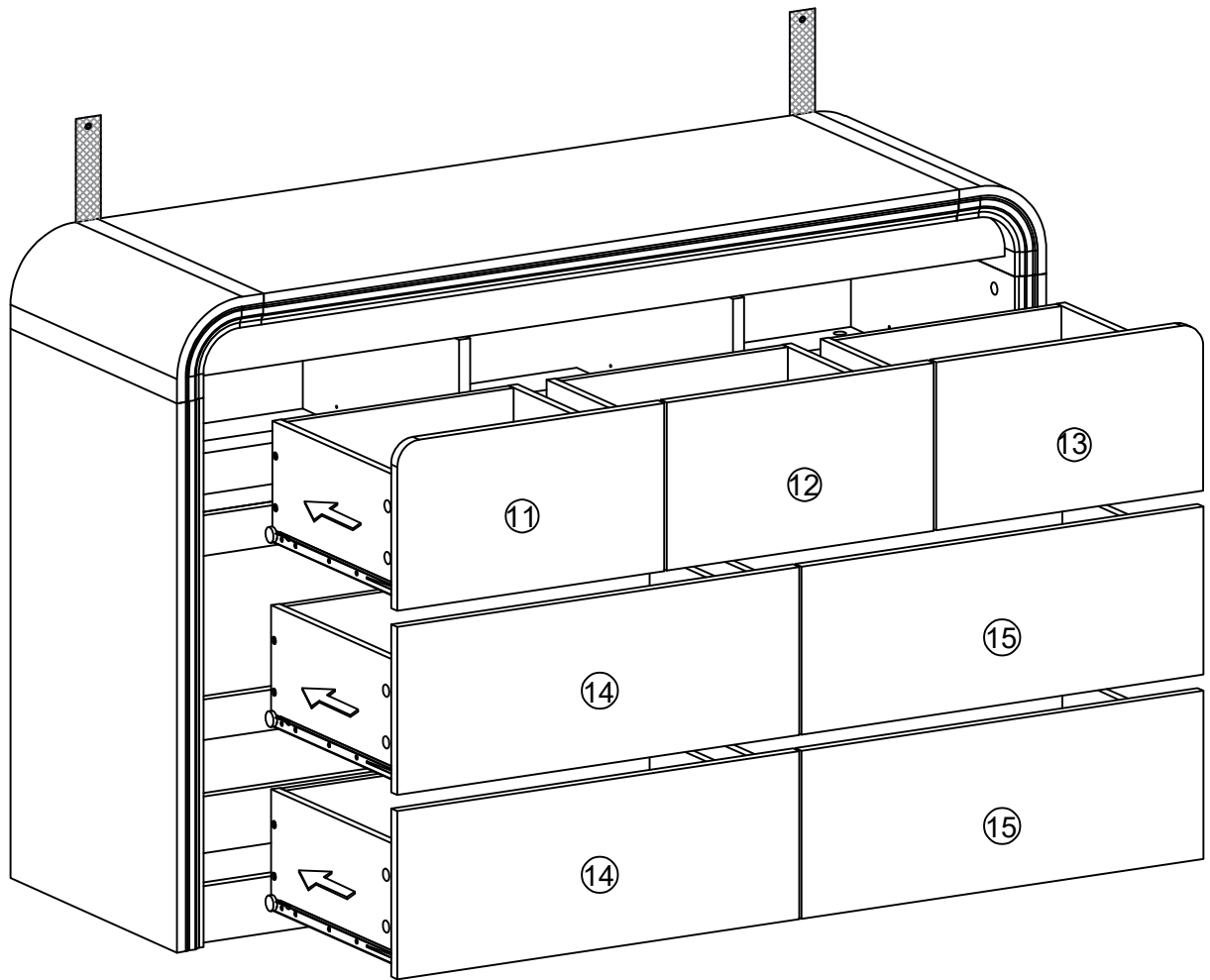

# Step 24

