

ASSEMBLY INSTRUCTIONS
FINE FURNITURE



California King Bed



ASSEMBLY INSTRUCTIONS

ASSEMBLY TIPS:

1. Remove hardware from box and sort by size.
2. Please check to see that all hardware and parts are present prior to start of assembly.
3. Please follow attached instructions in the same sequence as numbered to assure fast & easy assembly.



WARNING!

1. Don't attempt to repair or modify parts that are broken or defective. Please contact the store immediately.
2. This product is for home use only and not intended for commercial establishments.



ASSEMBLY TIME

40 MINUTES

PARTS IDENTIFICATION

B1 (BOX 1)

A HEADBOARD PANEL

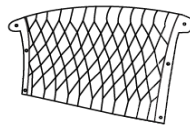

1PC

B HEADBOARD LEG

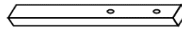

2PCS

C HEADBOARD SUPPORT PANEL

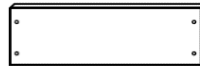

1PC

B2 (BOX 2)

D1 LEFT WING

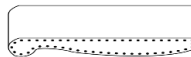

1PC

D2 RIGHT WING



1PC

E WING SUPPORT



2PCS

B3 (BOX 3)

F FOOTBOARD PANEL

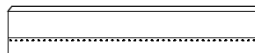

1PC

G1 LEFT BED RAIL



1PC

G2 RIGHT BED RAIL

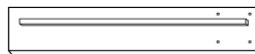

1PC

NOTE:

Phillips head screw driver is required in the assembly process; however, manufacturer does not provide this item.

ASSEMBLY INSTRUCTIONS

ASSEMBLY TIPS:









1. Remove hardware from box and sort by size.
2. Please check to see that all hardware and parts are present prior to start of assembly.
3. Please follow attached instructions in the same sequence as numbered to assure fast & easy asse



WARNING!

1. Don't attempt to repair or modify parts that are broken or defective. Please contact the store immediately.
2. This product is for home use only and not intended for commercial establishments.

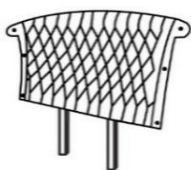
PARTS IDENTIFICATION

H	BED SLAT WITHOUT HOLE		10PCS
I	BED SLAT WITH HOLES		3PCS
J	BED SLAT SUPPORT		6PCS
K	FOOTBOARD LEG		2PCS
L	CENTER RAIL		2PCS
M	CENTER RAIL SUPPORT		2PCS
HB	300643KW (B1) FROM BOX 1 HEADBOARD COMPLETE		1PC
ER1	300643KW (B2) FROM BOX 2 WING COMPLETE		1PC
ER2	300643KW (B2) FROM BOX 2 WING COMPLETE		1PC

NOTE:

Phillips head screw driver is required in the assembly process; however, manufacturer does not provide this item.

ASSEMBLY INSTRUCTIONS

ASSEMBLY TIPS:

1. Remove hardware from box and sort by size.
2. Please check to see that all hardware and parts are present prior to start of assembly.
3. Please follow attached instructions in the same sequence as numbered to assure fast & easy assembly.











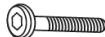

WARNING!

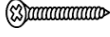
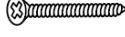
1. Don't attempt to repair or modify parts that are broken or defective. Please contact the store immediately.
2. This product is for home use only and not intended for commercial establishments.

HARDWARE IDENTIFICATION

Z-B3 (BOX 3) - HARDWARE PACK IS LOCATED IN 300643KW (B3)

1	ALLEN WRENCH (Φ6 - BLK)		1PC
2	BOLT 1 (Φ6 X 30mm - RBW)		4PCS
3	BOLT 2 (Φ6 X 45mm - RBW)		12PCS
4	BOLT 3 (Φ6 X 60mm - RBW)		10PCS
5	BOLT 4 (Φ6 X 90mm - RBW)		8PCS
6	SHORT FLAT HEAD SCREW (Φ4 X 16mm - RBW)		8PCS
7	MEDIUM FLAT HEAD SCREW (Φ4 X 32mm - RBW)		28PCS
8	LONG FLAT HEAD SCREW (Φ4 X 45mm - RBW)		4PCS
9	BIG FLAT WASHER (Φ3/8 X 25 X 1 - RBW)		24PCS
10	MEDIUM FLAT WASHER (Φ7 X 19 X 2 - RBW)		24PCS
11	SMALL FLAT WASHER (Φ6 X 13 X 1 - RBW)		4PCS
12	LOCK WASHER (Φ6 - RBW)		24PCS
13	LEVELER (Φ6 X 23mm - RBW)		6PCS

NOTE:

Phillips head screw driver is required in the assembly process; however, manufacturer does not provide this item.

ASSEMBLY INSTRUCTIONS STEP 1

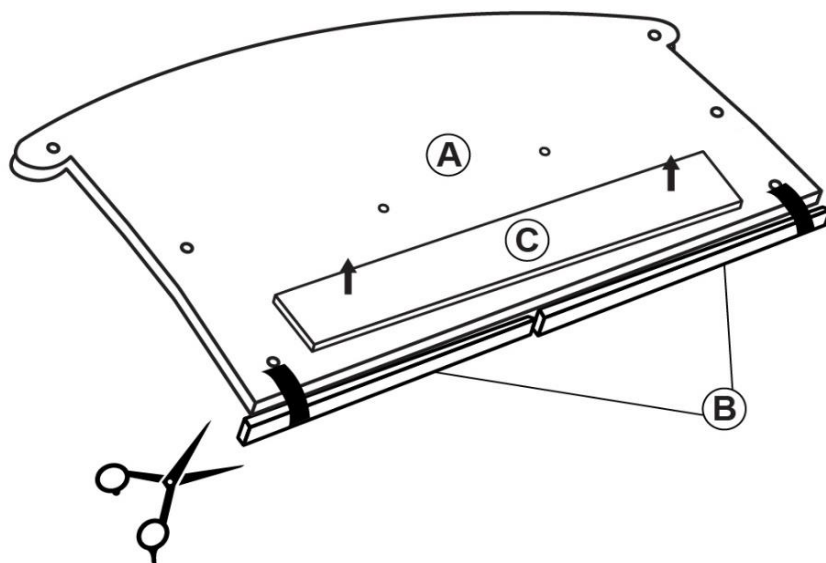

STEP 2

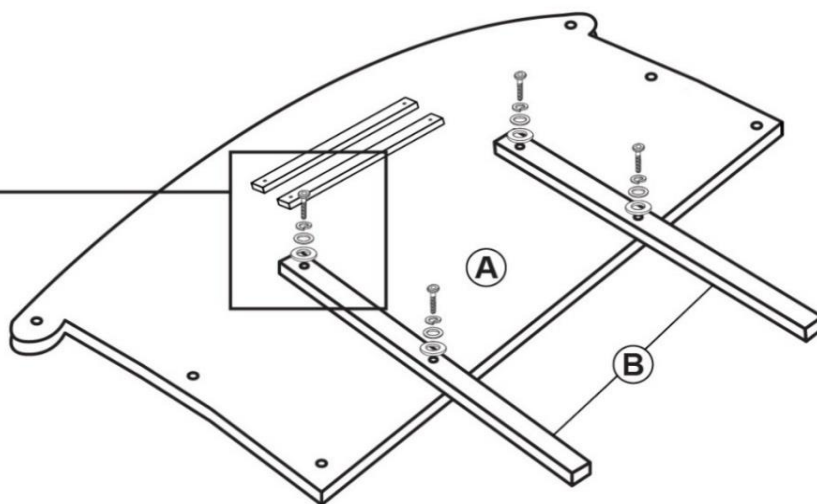
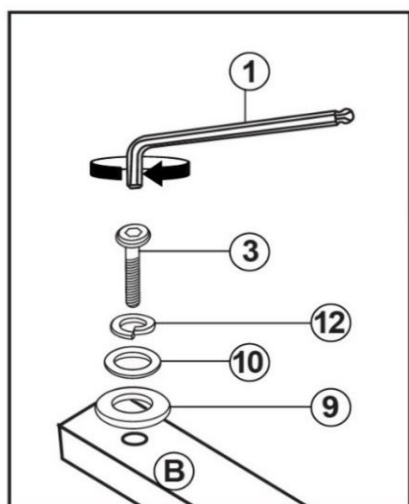

ASSEMBLY INSTRUCTIONS STEP 3

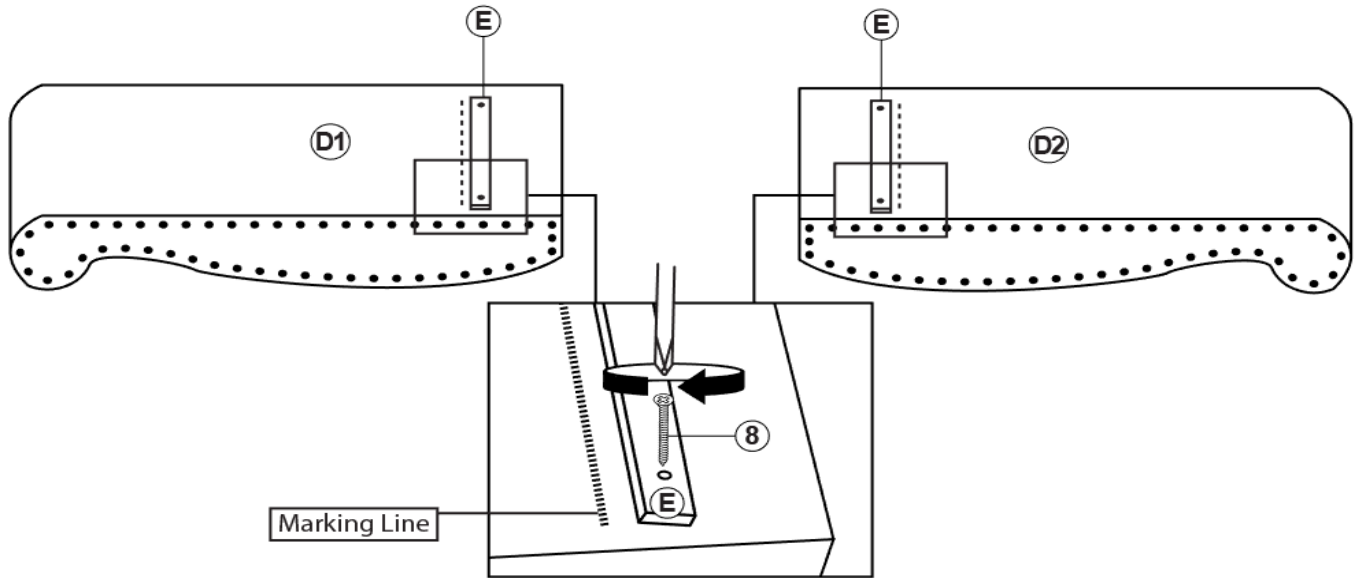

*Assemble wing support at the bottom of the marking line.

STEP 4

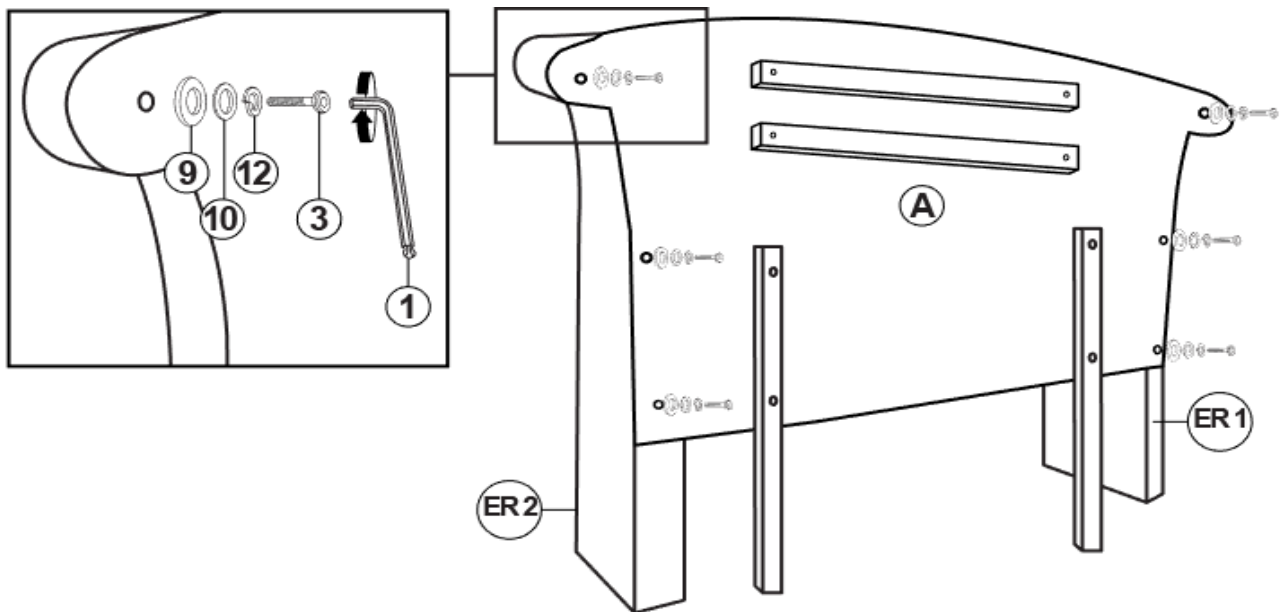

ASSEMBLY INSTRUCTIONS STEP 5

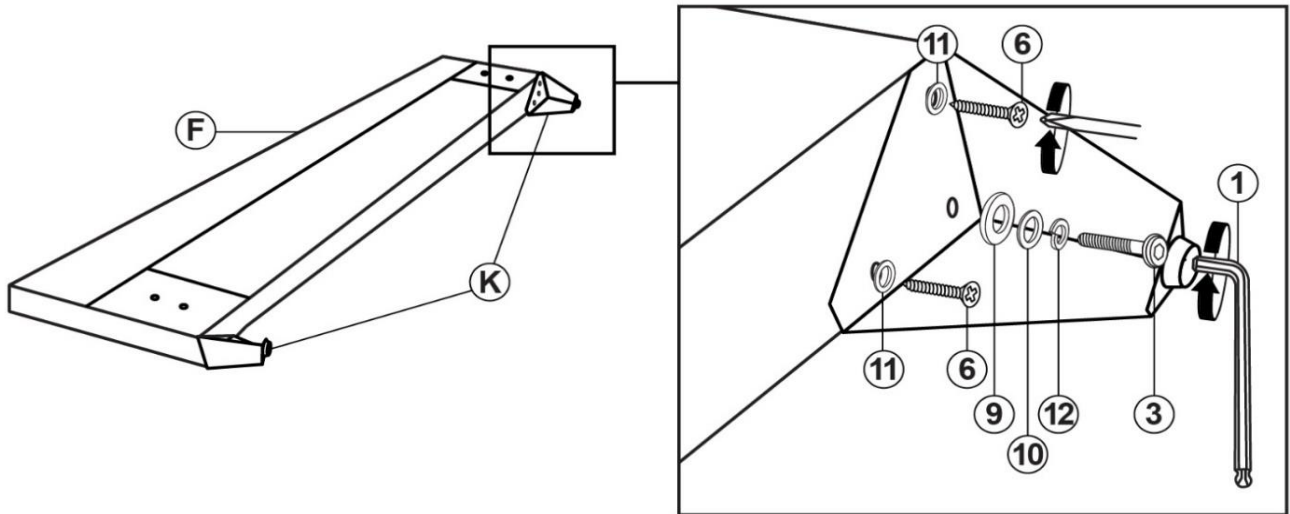

STEP 6

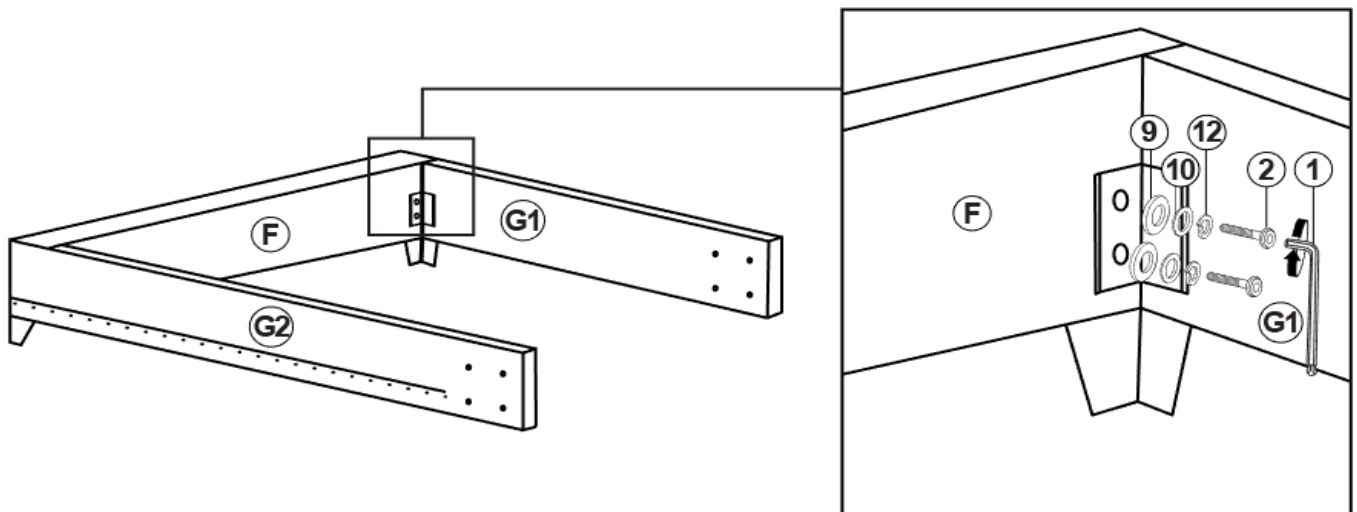

ASSEMBLY INSTRUCTIONS STEP 7

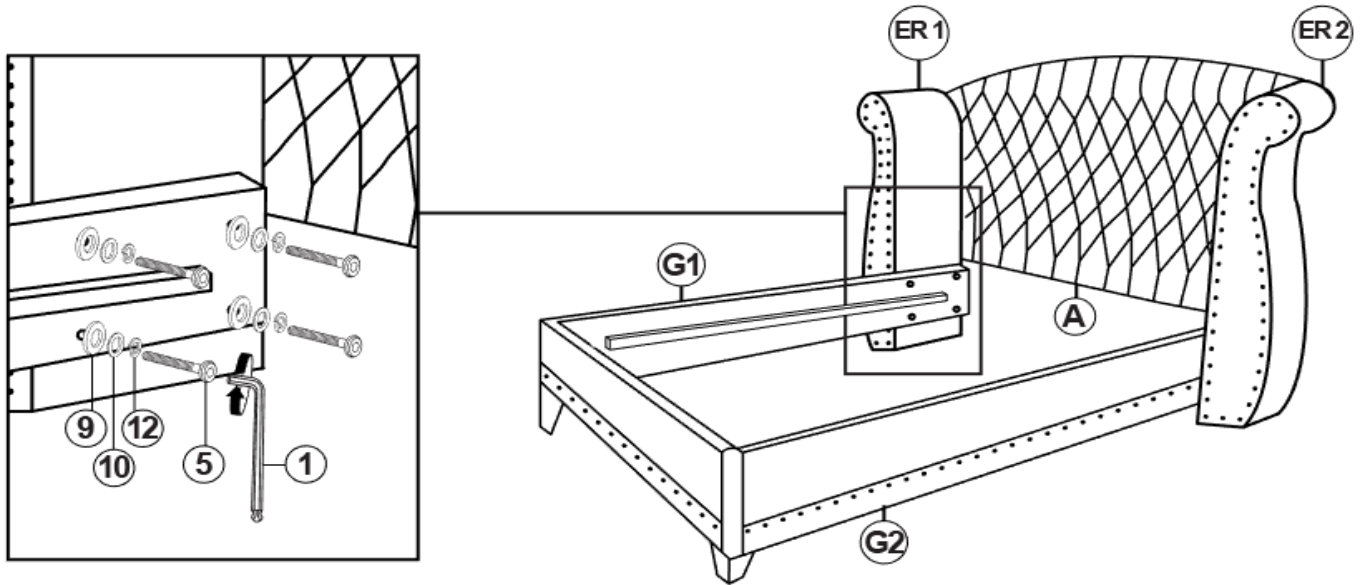

STEP 8

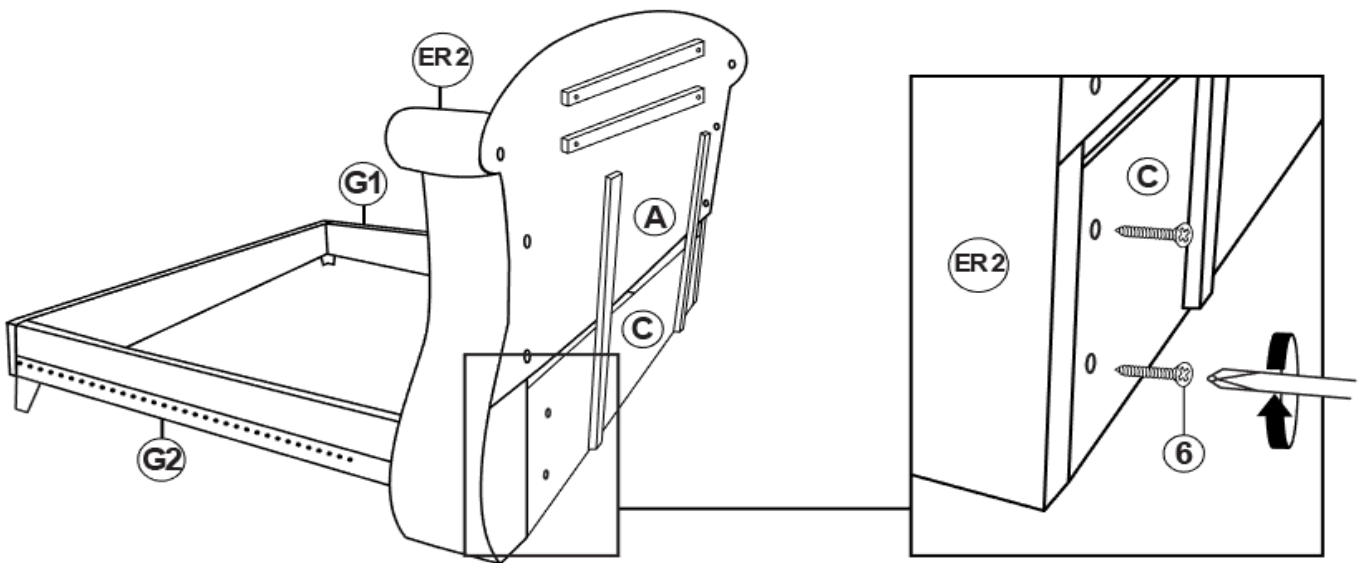

ASSEMBLY INSTRUCTIONS STEP 9

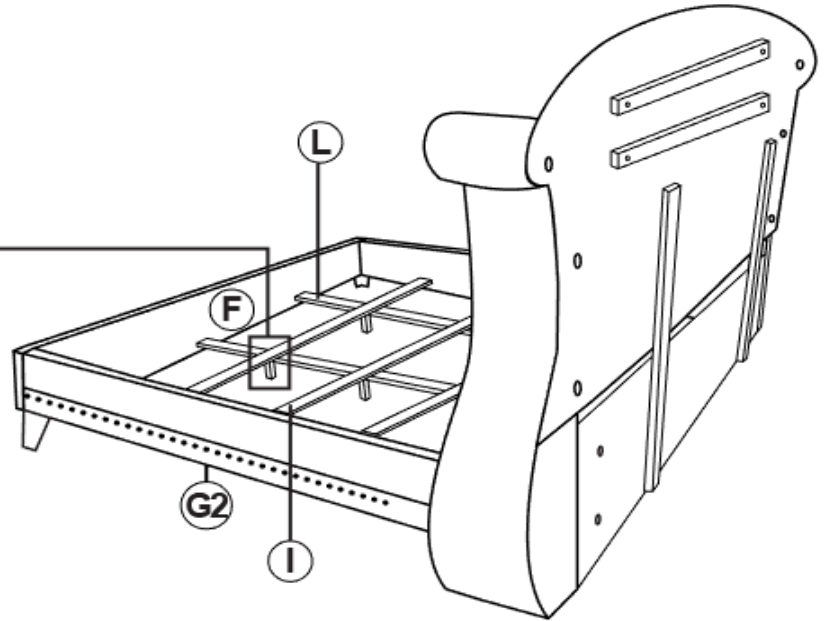
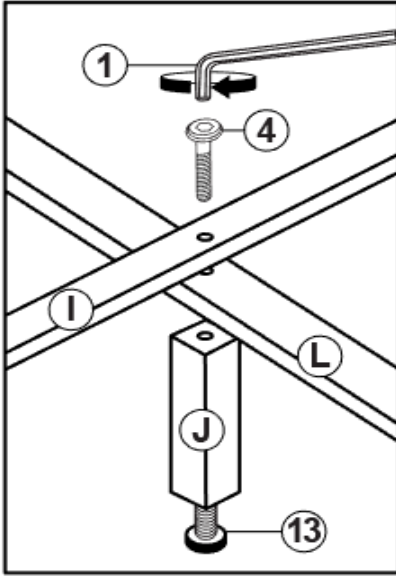

STEP 10

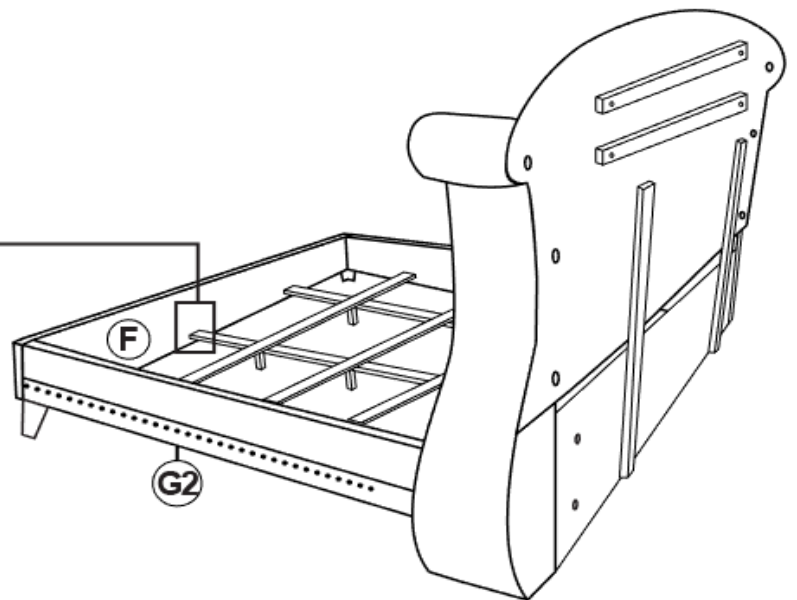
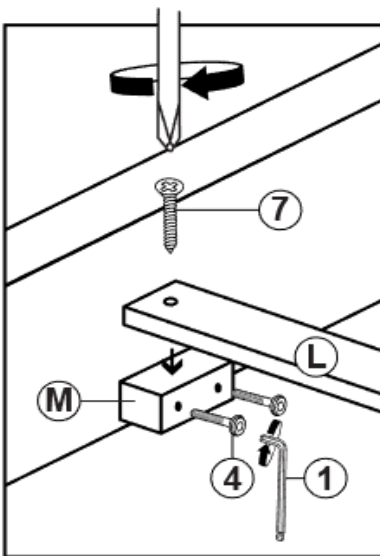

ASSEMBLY INSTRUCTIONS STEP 11

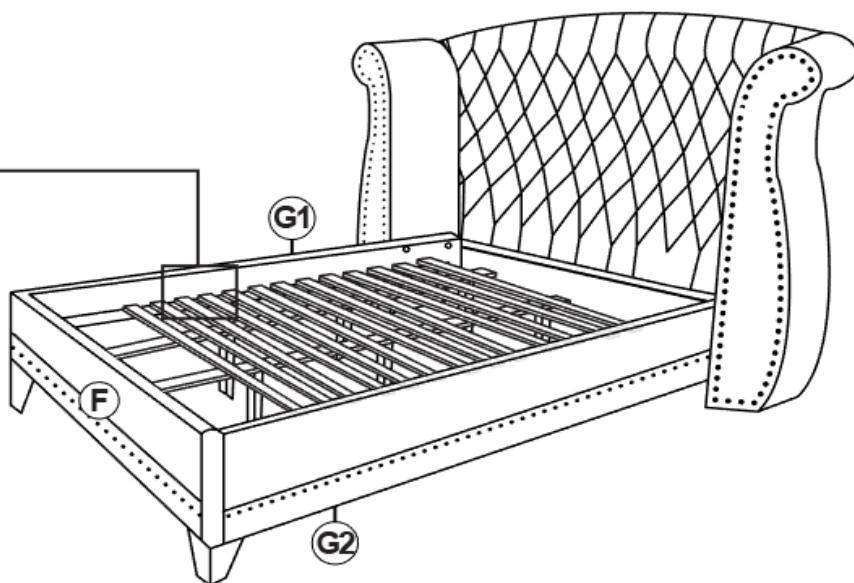
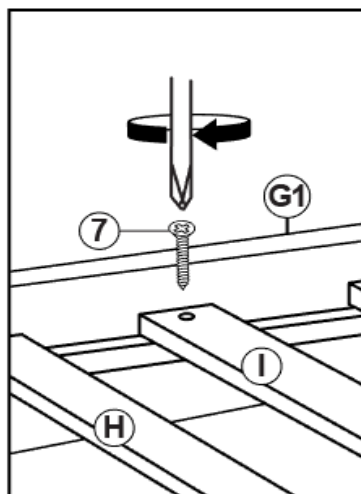

STEP 12 COMPLETE

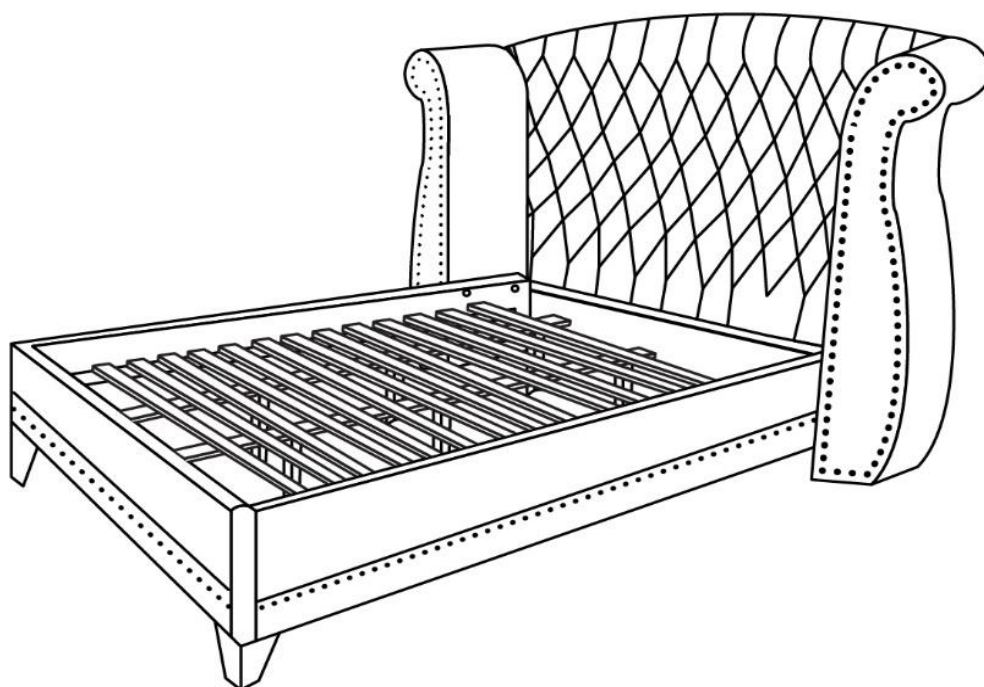

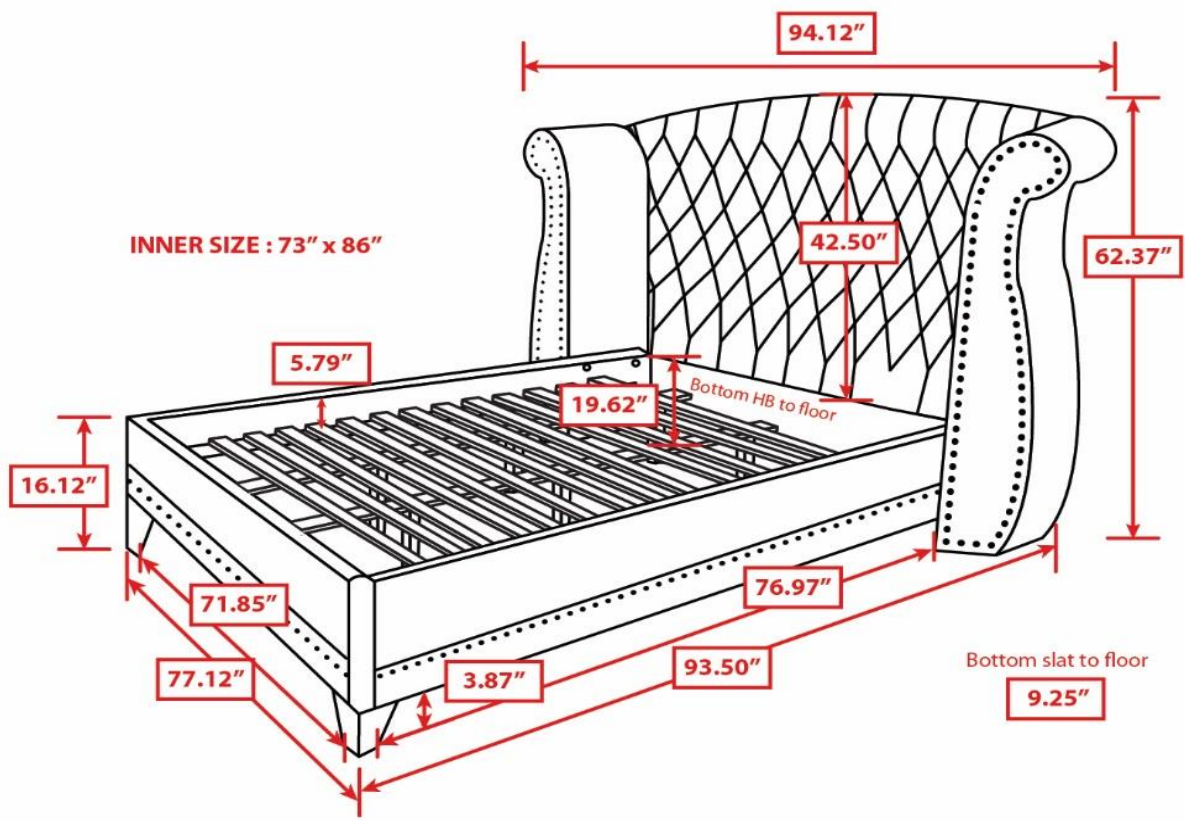

Note : Dimension tolerance $\pm 5\%$