

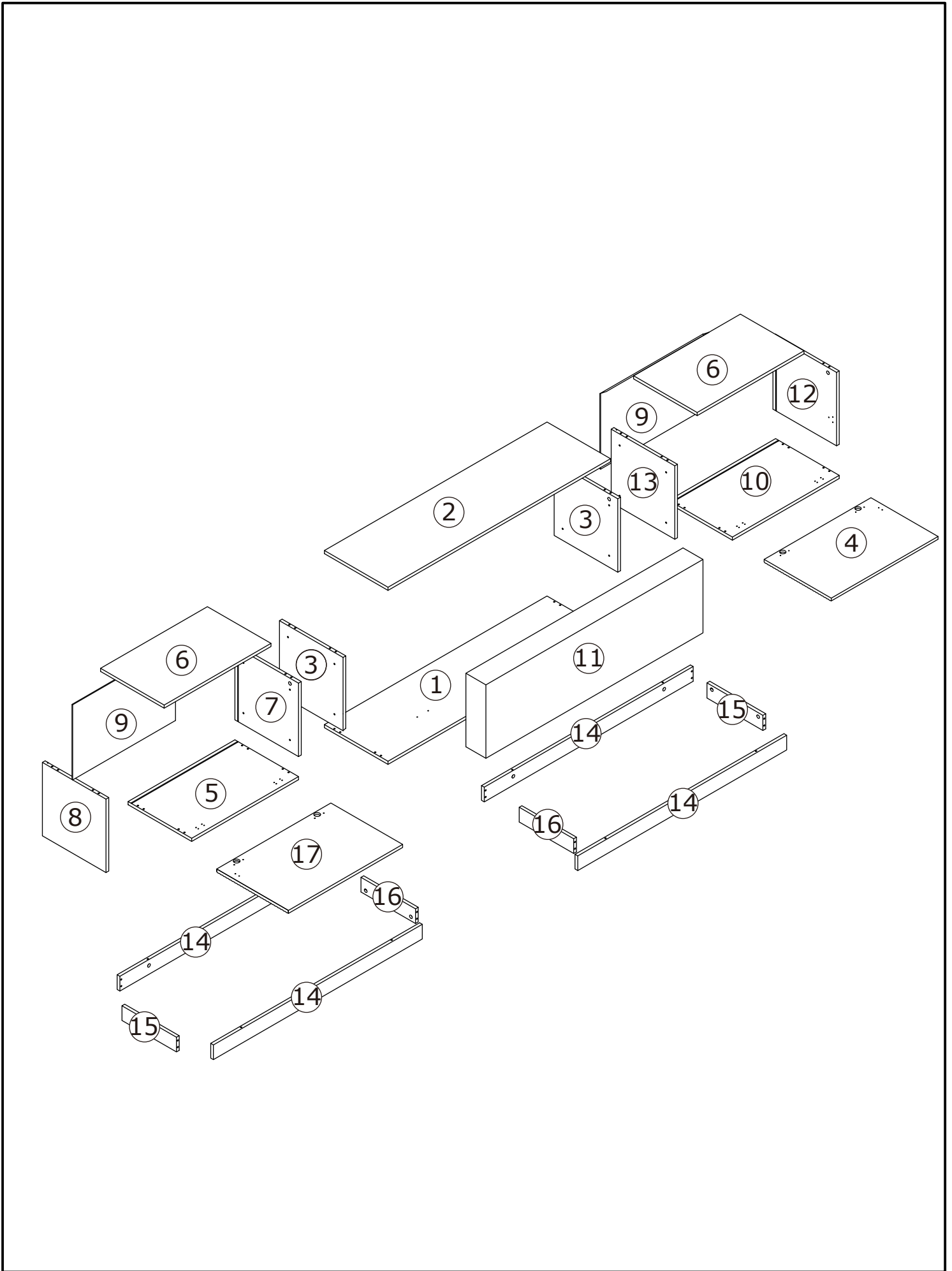

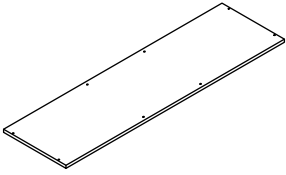

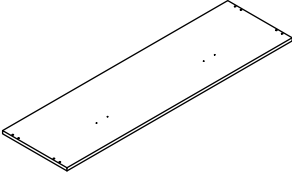

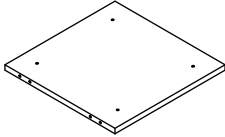
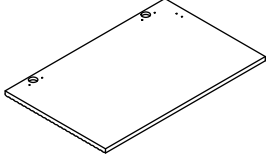
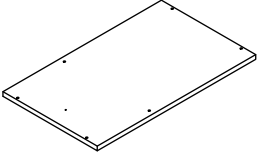
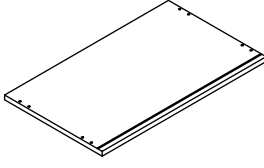
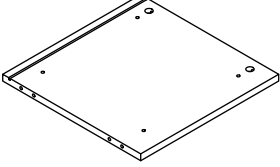
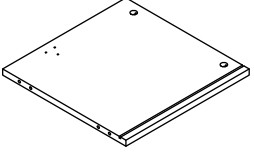
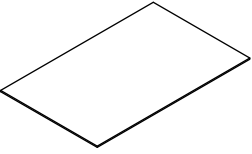
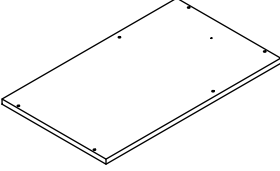
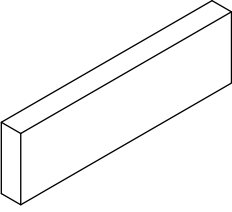
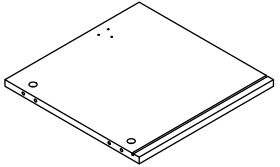
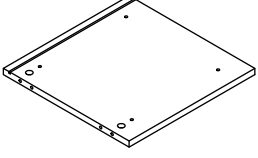
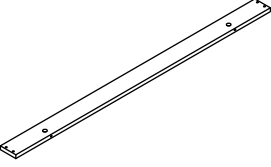
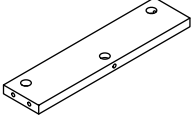
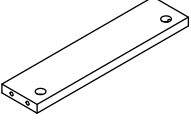
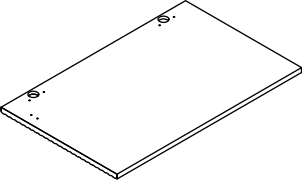

Installation instruction

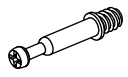

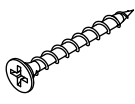
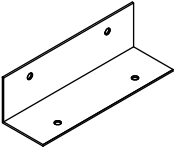
Parts and Operation Elements

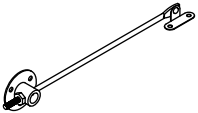
			
① 1pc	② 1pc	③ 2pc	④ 1pc
			
⑤ 1pc	⑥ 2pc	⑦ 1pcs	⑧ 1pc
			
⑨ 2pc	⑩ 1pc	⑪ 1pc	⑫ 1pc
			
⑬ 1pc	⑭ 4pc	⑮ 2pcs	⑯ 2pc
			
⑰ 1pc			

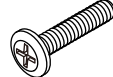
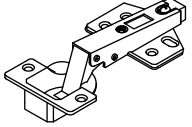
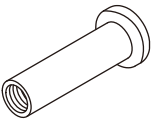
Hardware

									
A	30pcs	B	30pcs	C	32pcs	D	12pcs	E	4pcs
									
F	10pcs	G	2pcs	H	24pcs	J	8cs	K	4pcs
									
L	8pcs	M	8pcs	N	8pcs				



SPARE BAG

THE SPARE BAG INCLUDED EXTRA HARDWARE FOR DAMAGED OR MISSING SMALL HARDWARE WHILE YOU ARE ASSEMBLING

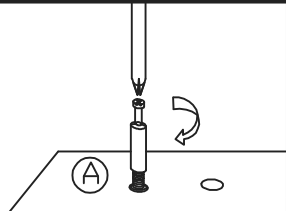
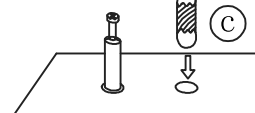
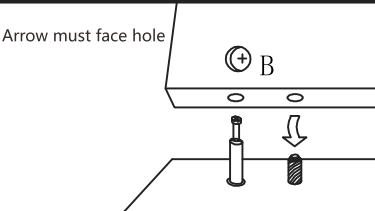
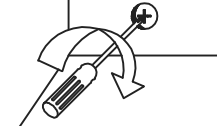
			
Gently screw cam bolt into the threaded anchor.	Insert the wood dowel halfway into hole.	Arrow must face hole	Screw the camlock firmly into locked position.

1

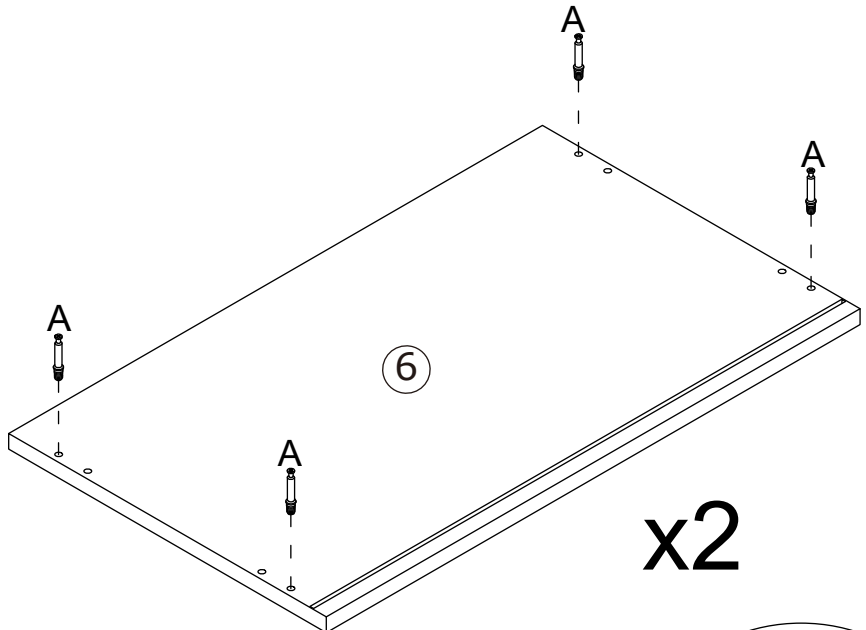
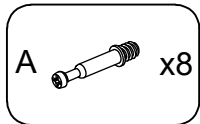

x2

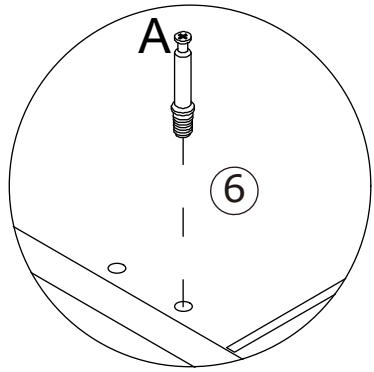

2

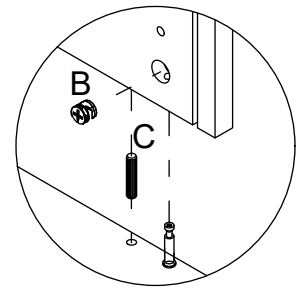
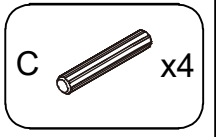
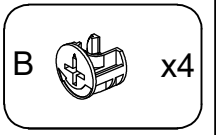
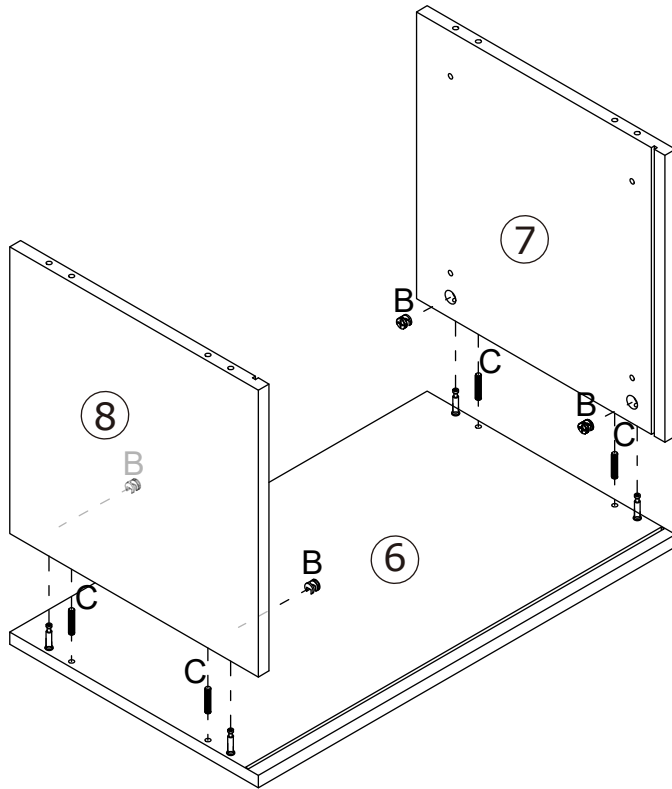

3

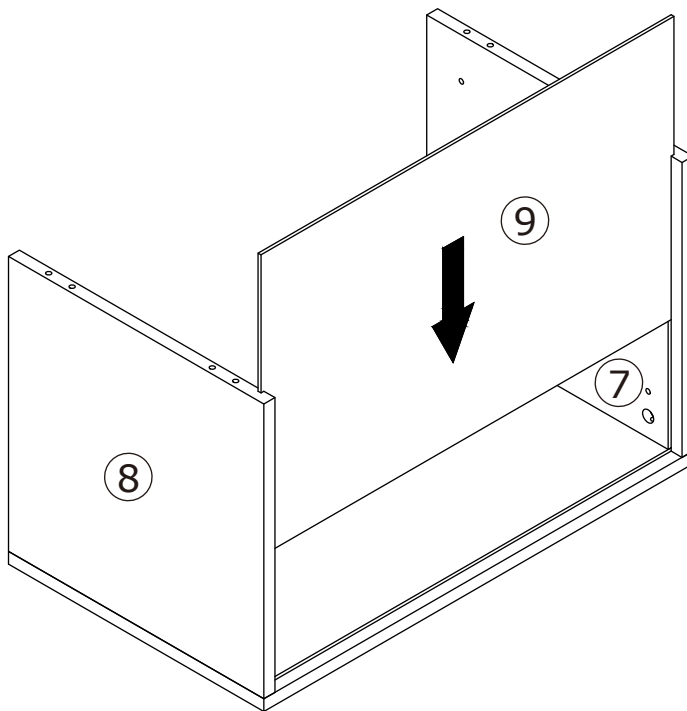

4

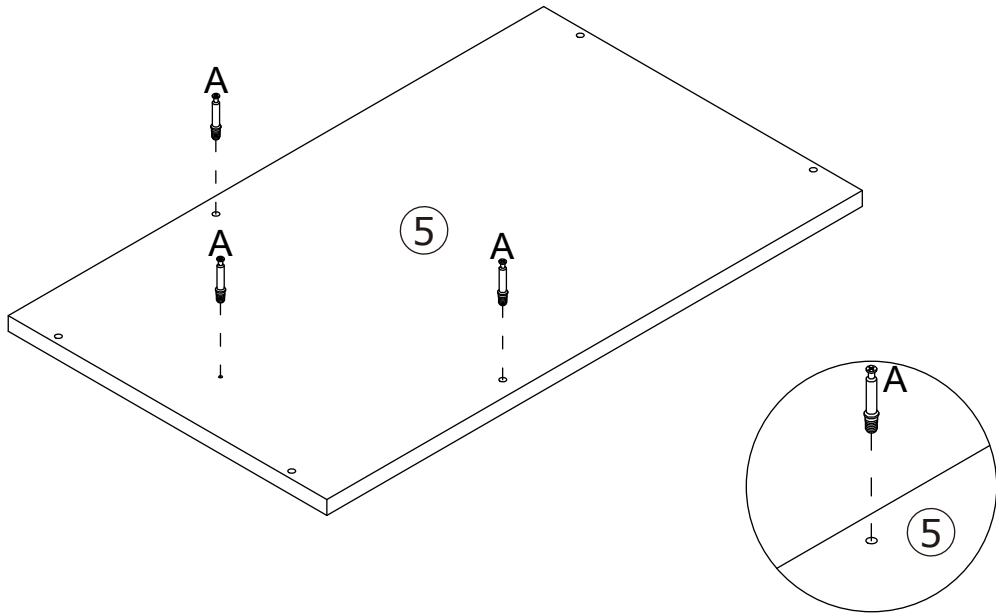
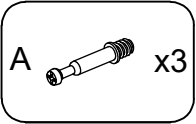

5

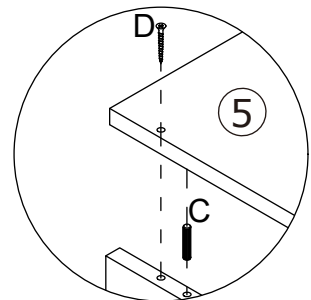
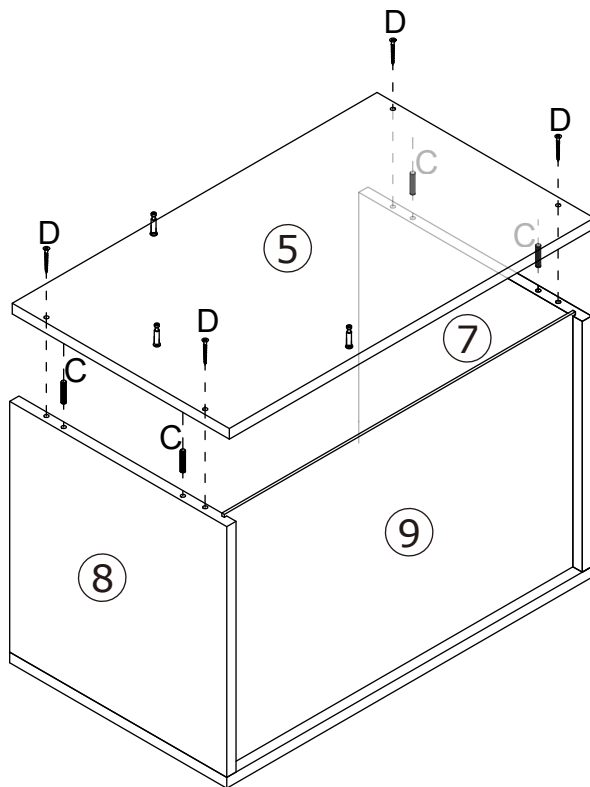
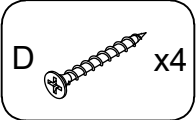
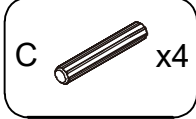

6

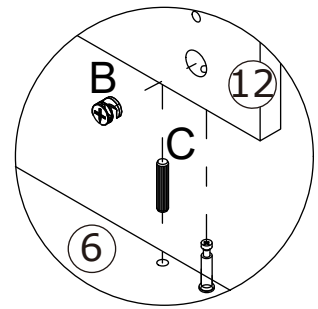
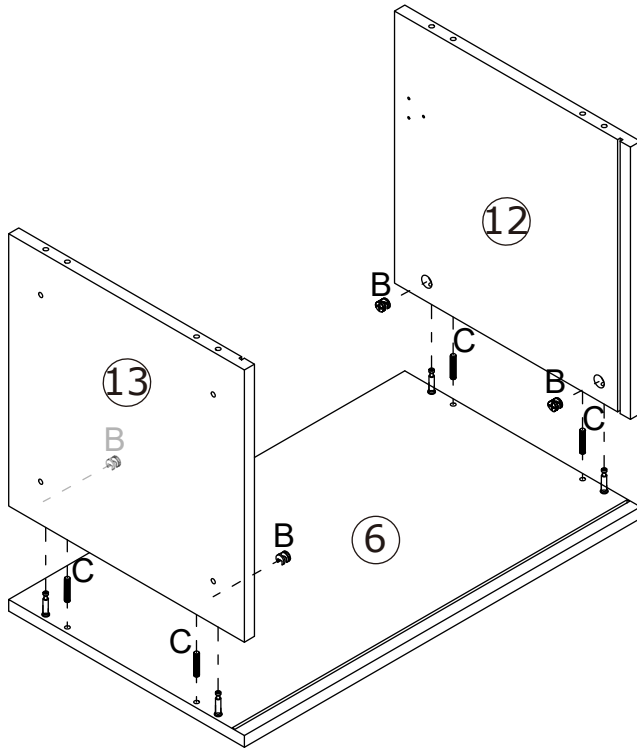
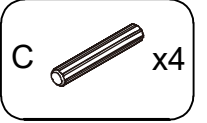
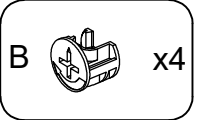

7

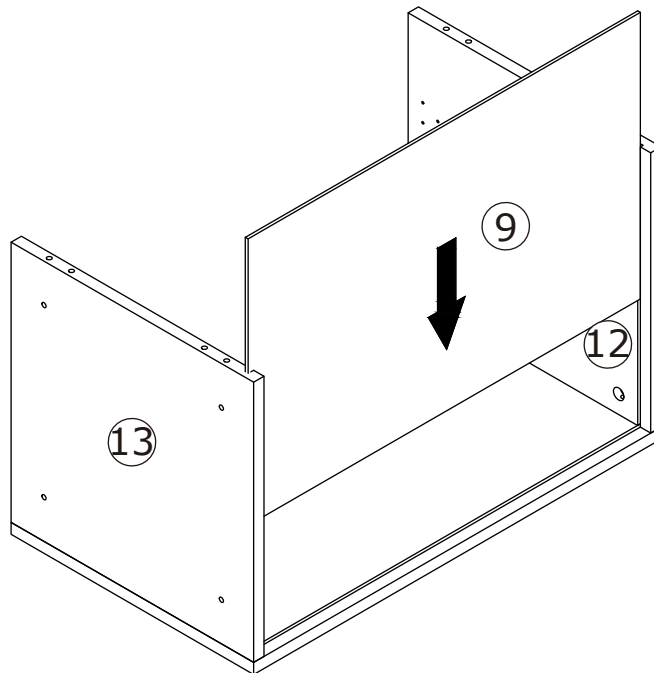

8

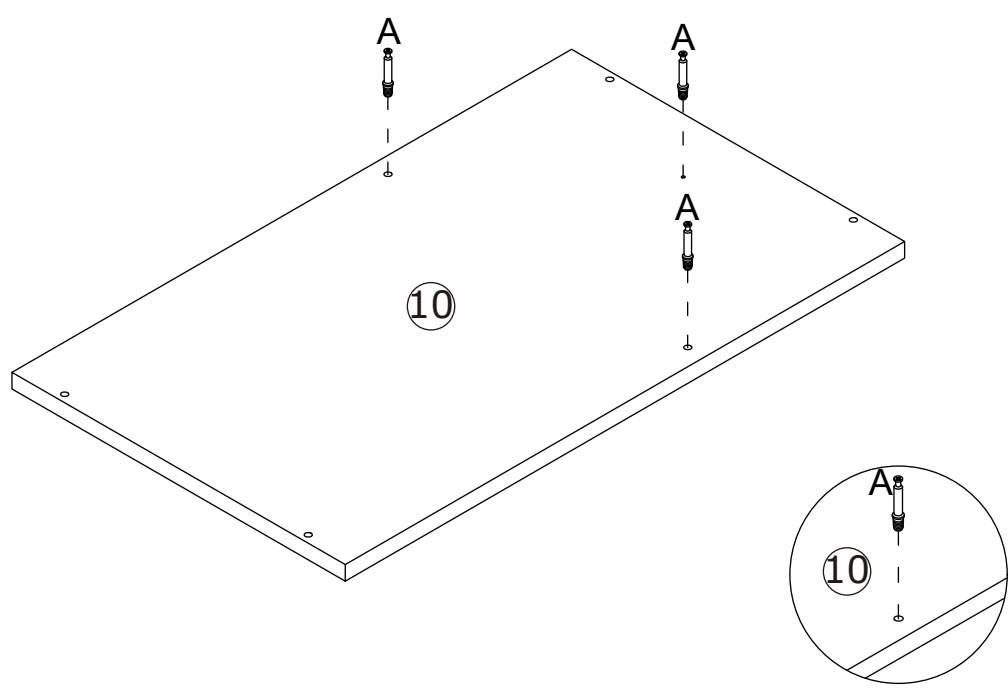
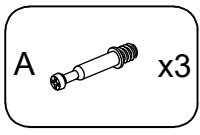

9

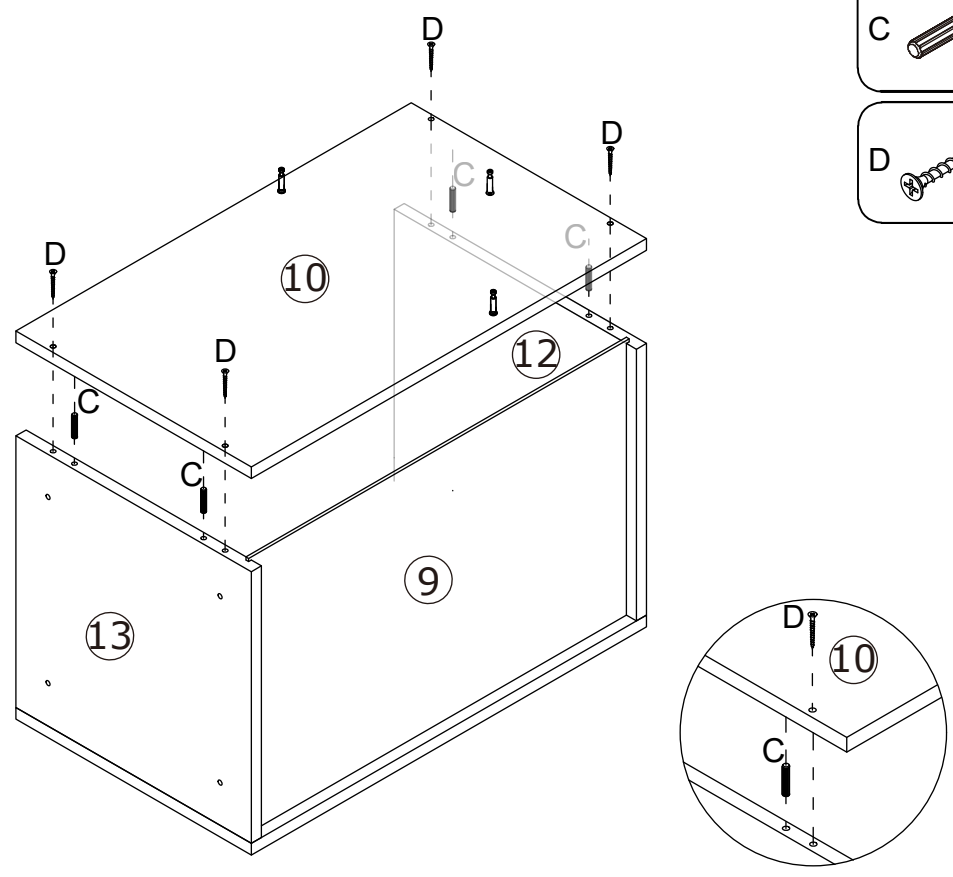
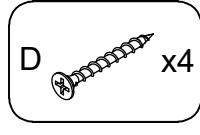
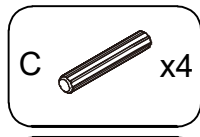

10

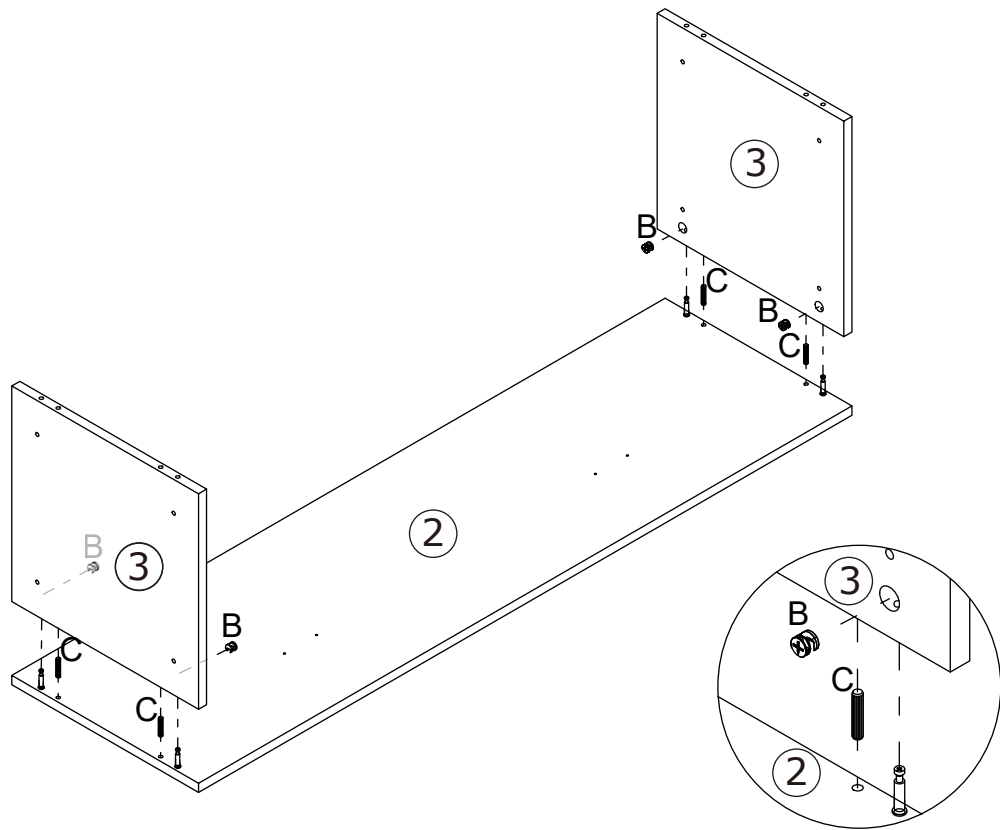
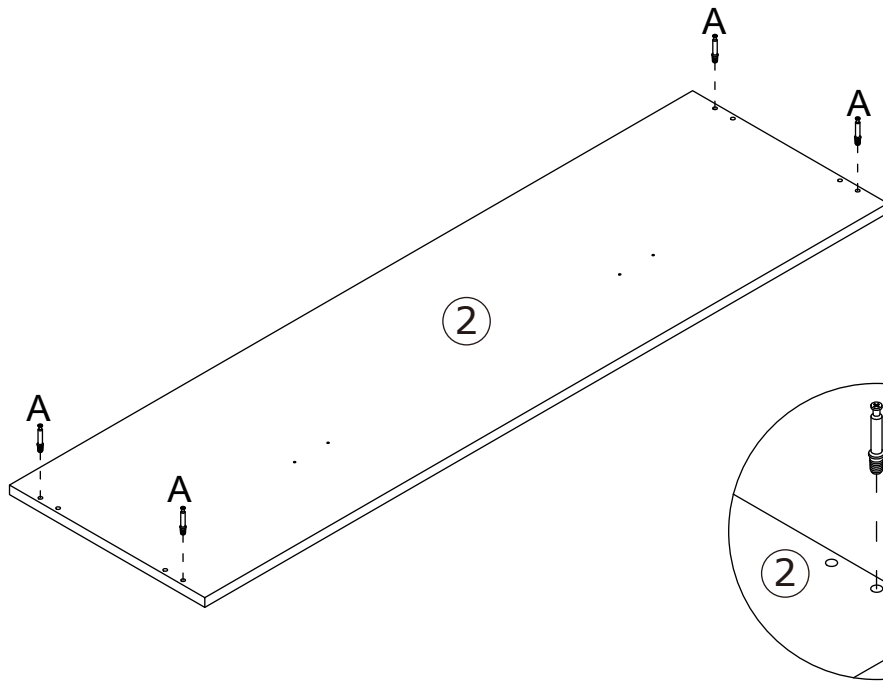
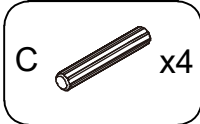
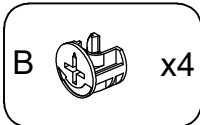
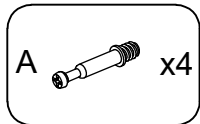

11

A  x4

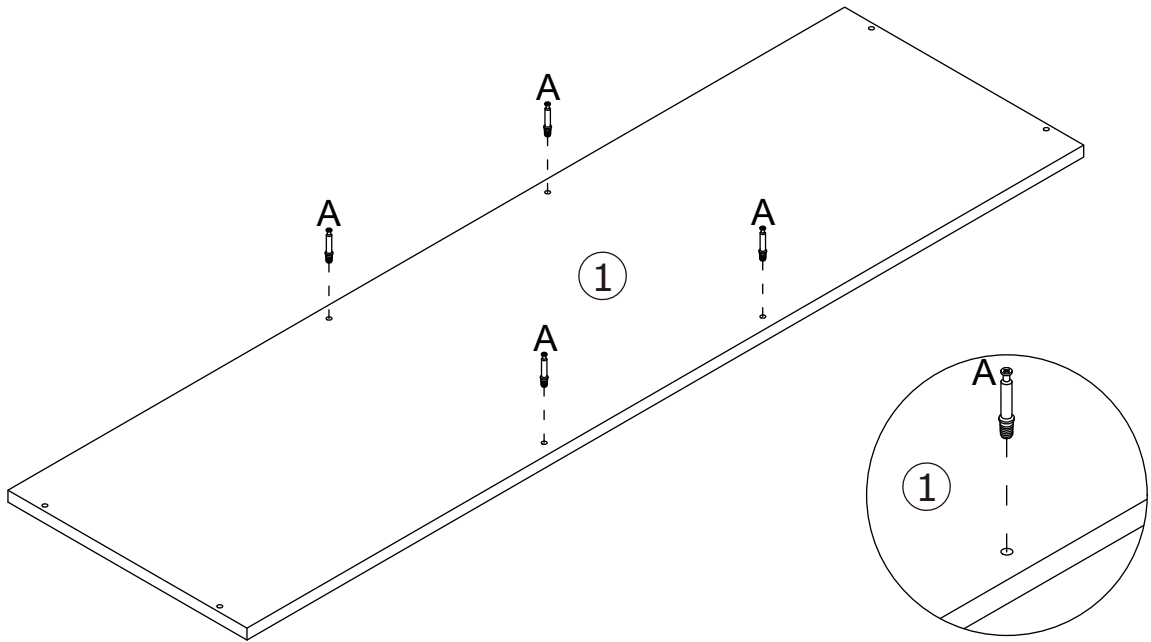

12

C  x4

D  x4

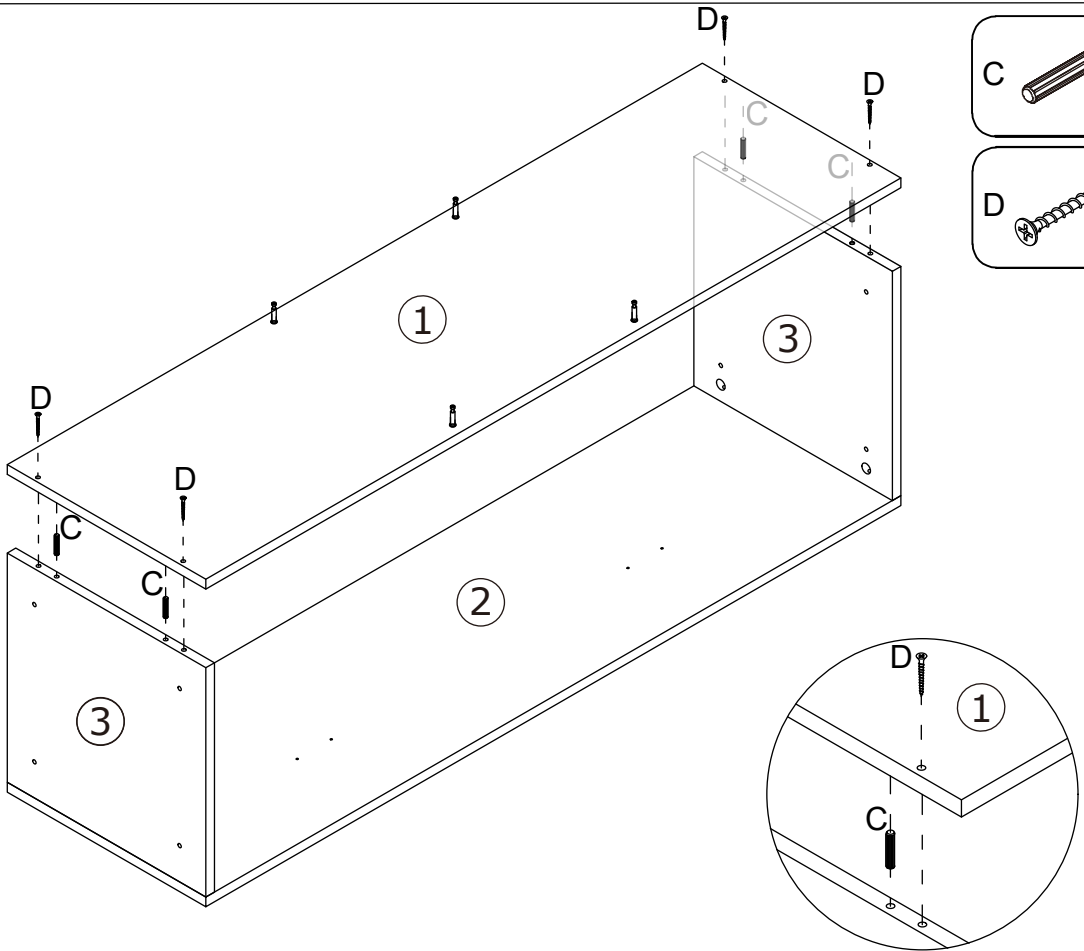

13

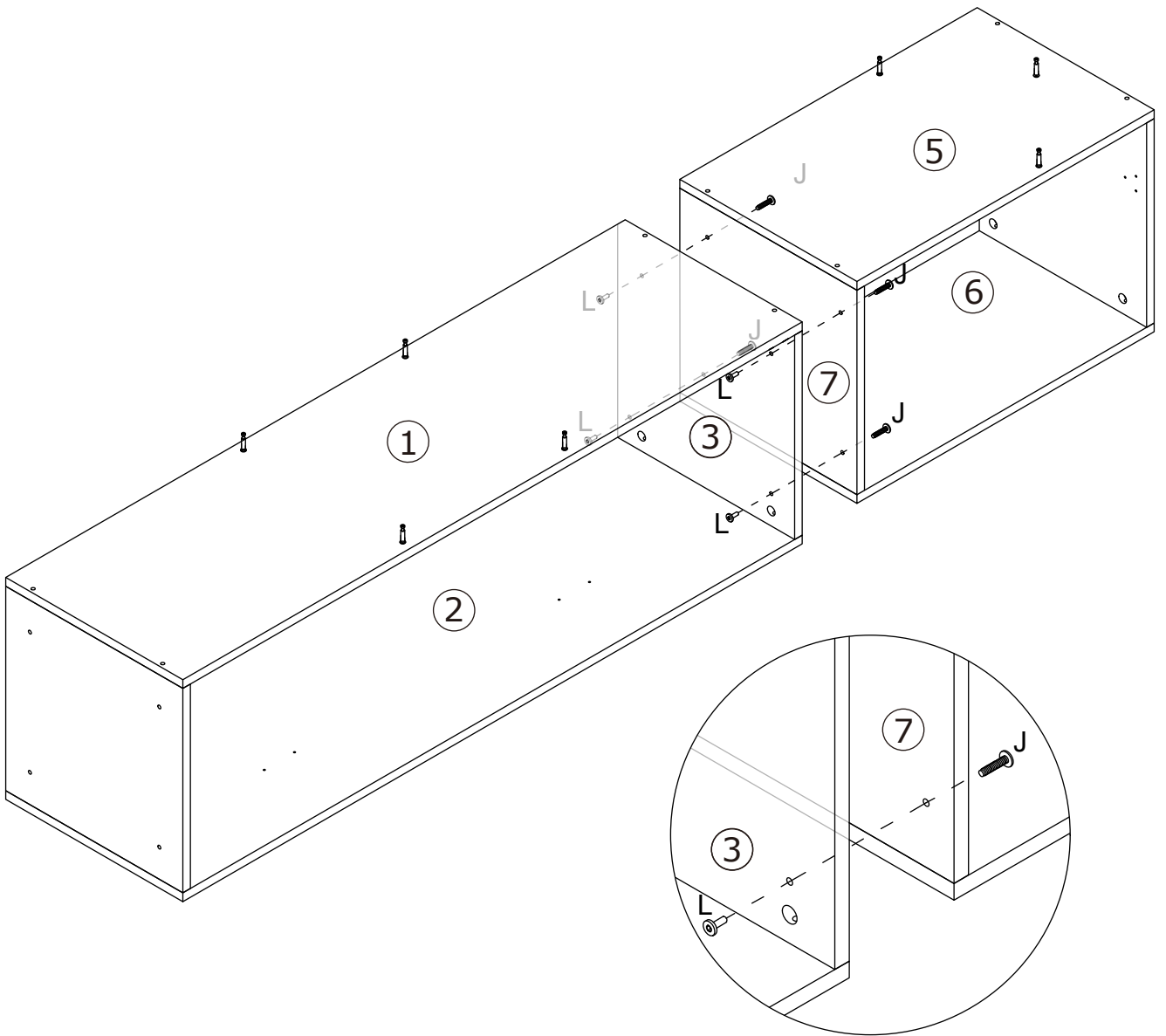
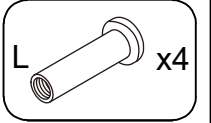
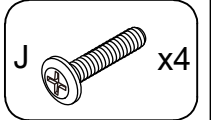

14

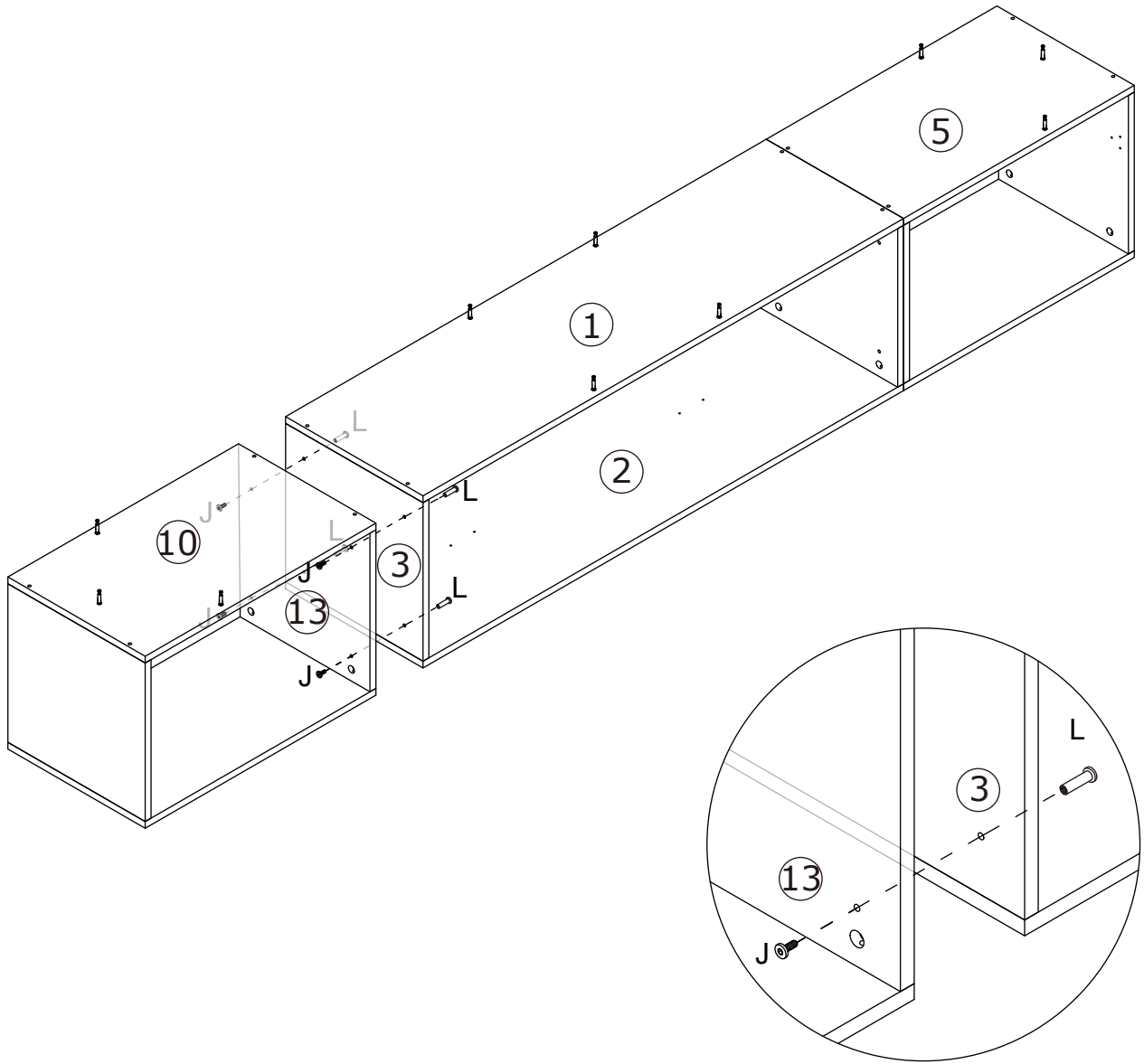
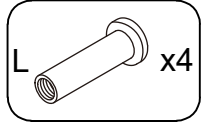
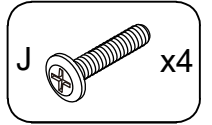

15

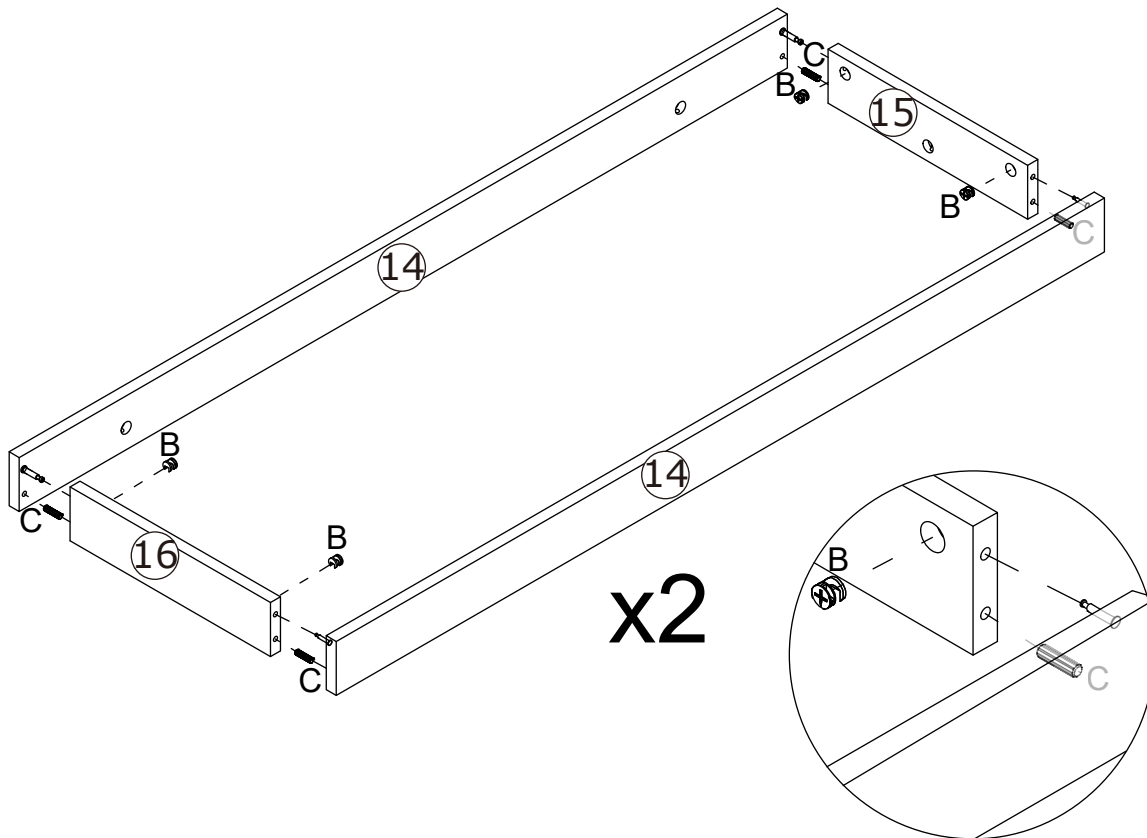
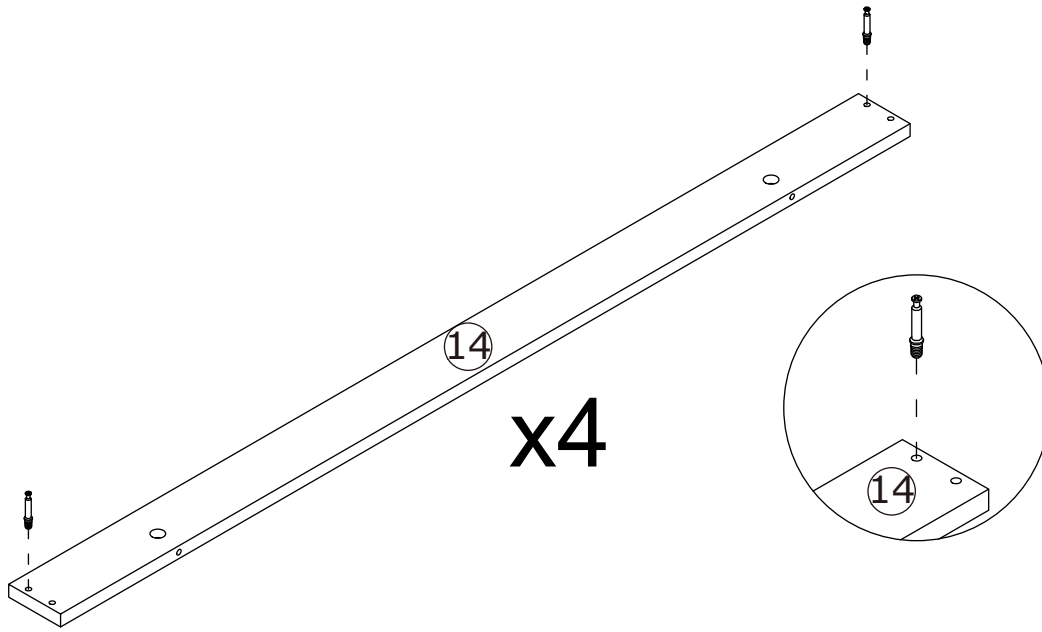
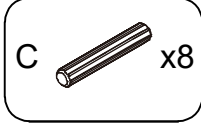
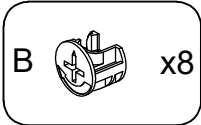
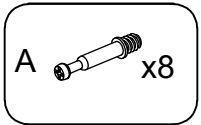

16

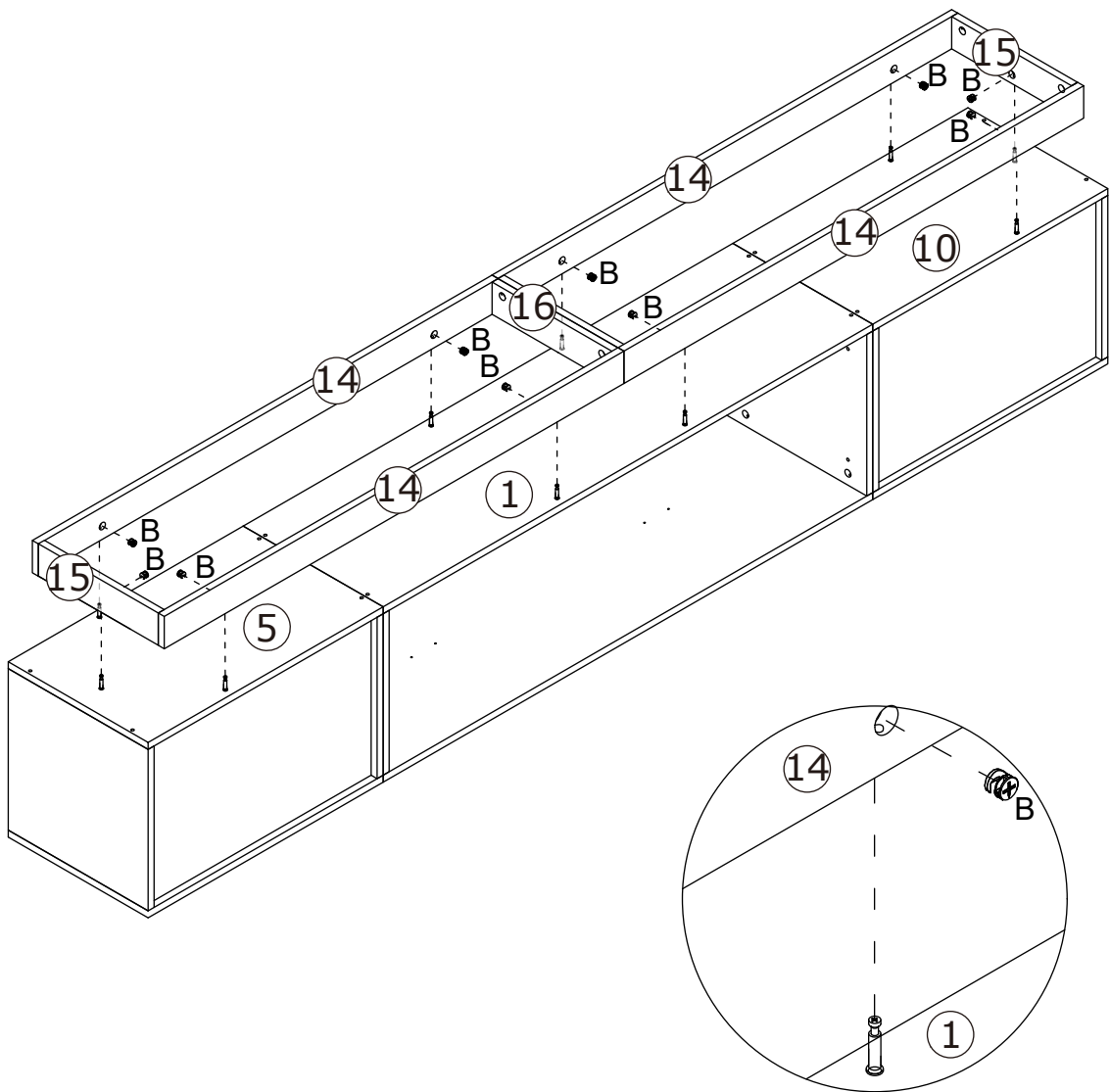
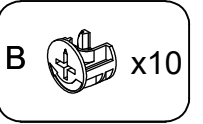

17

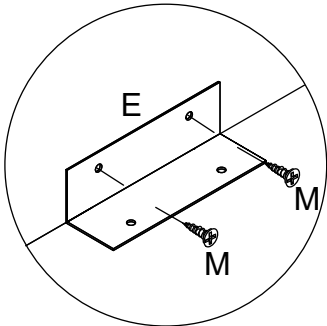
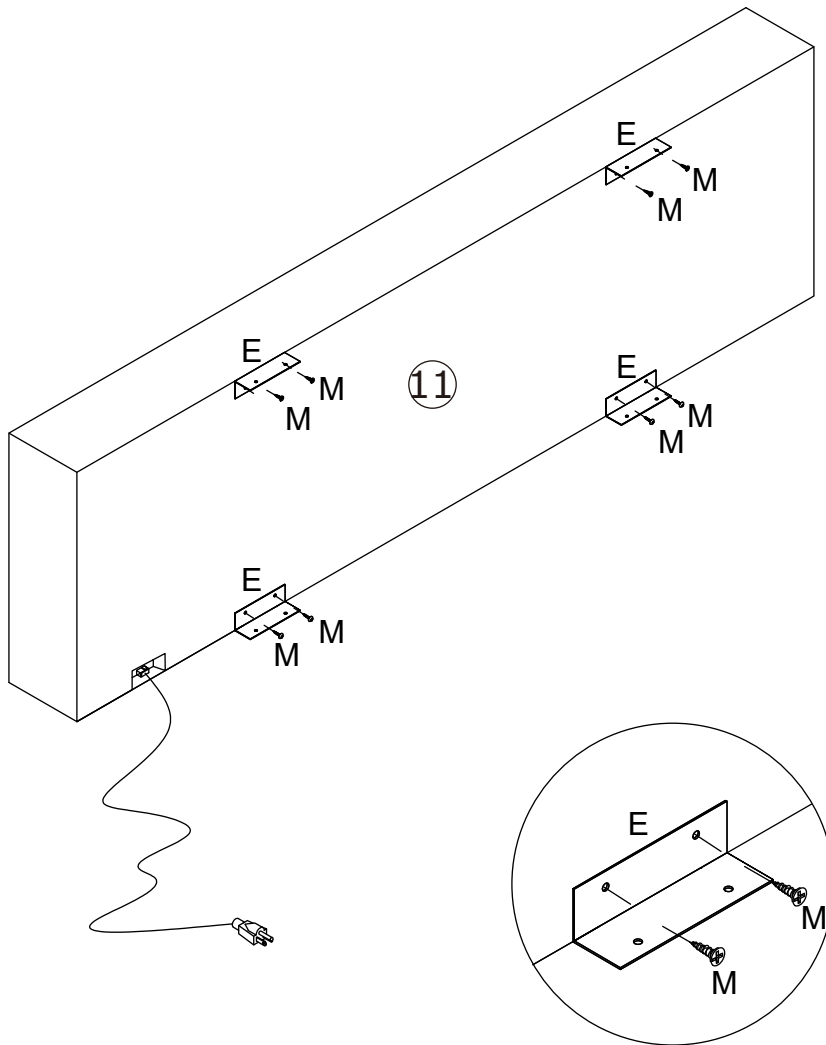
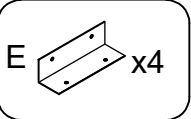

18

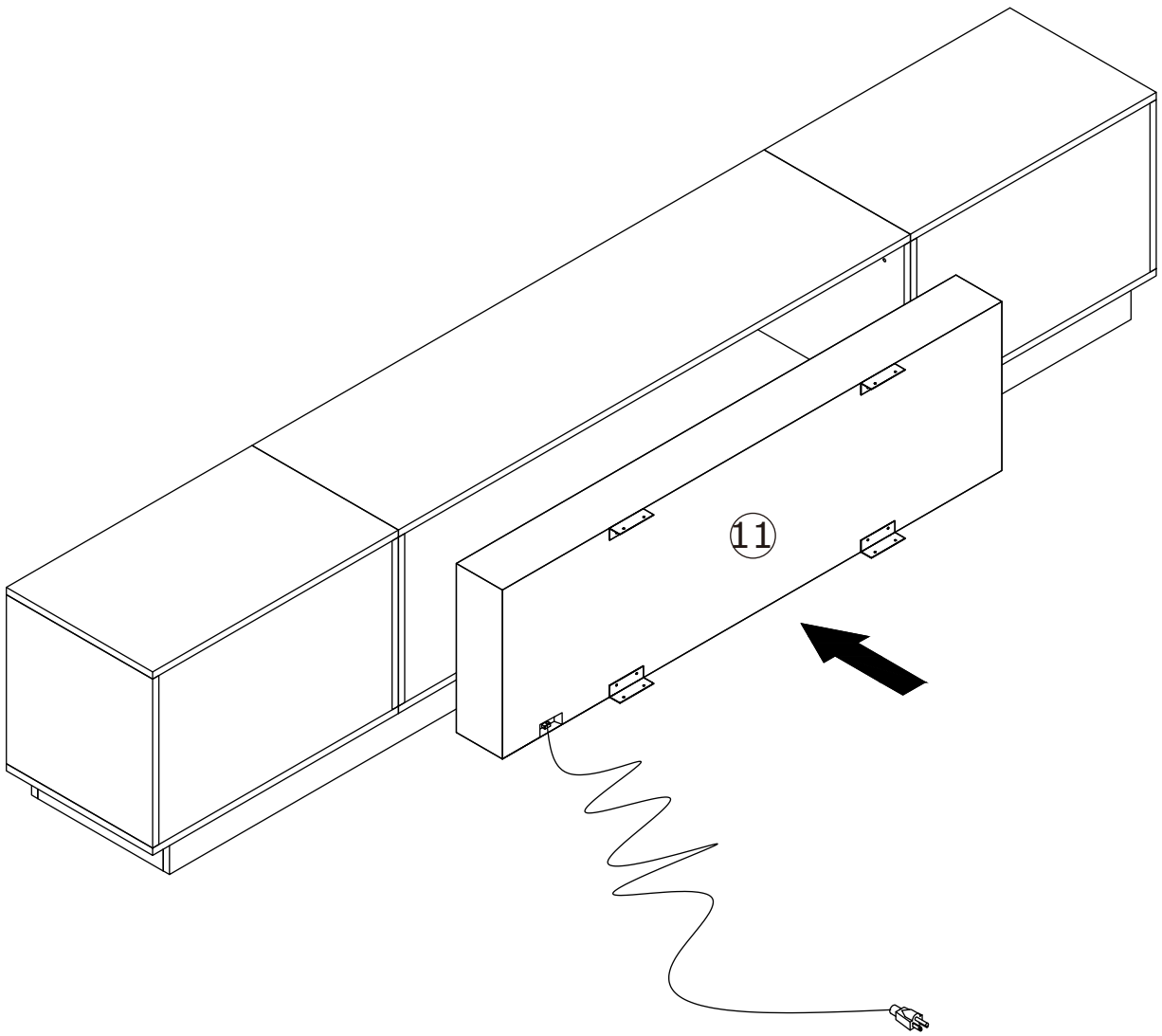

19

N  x8

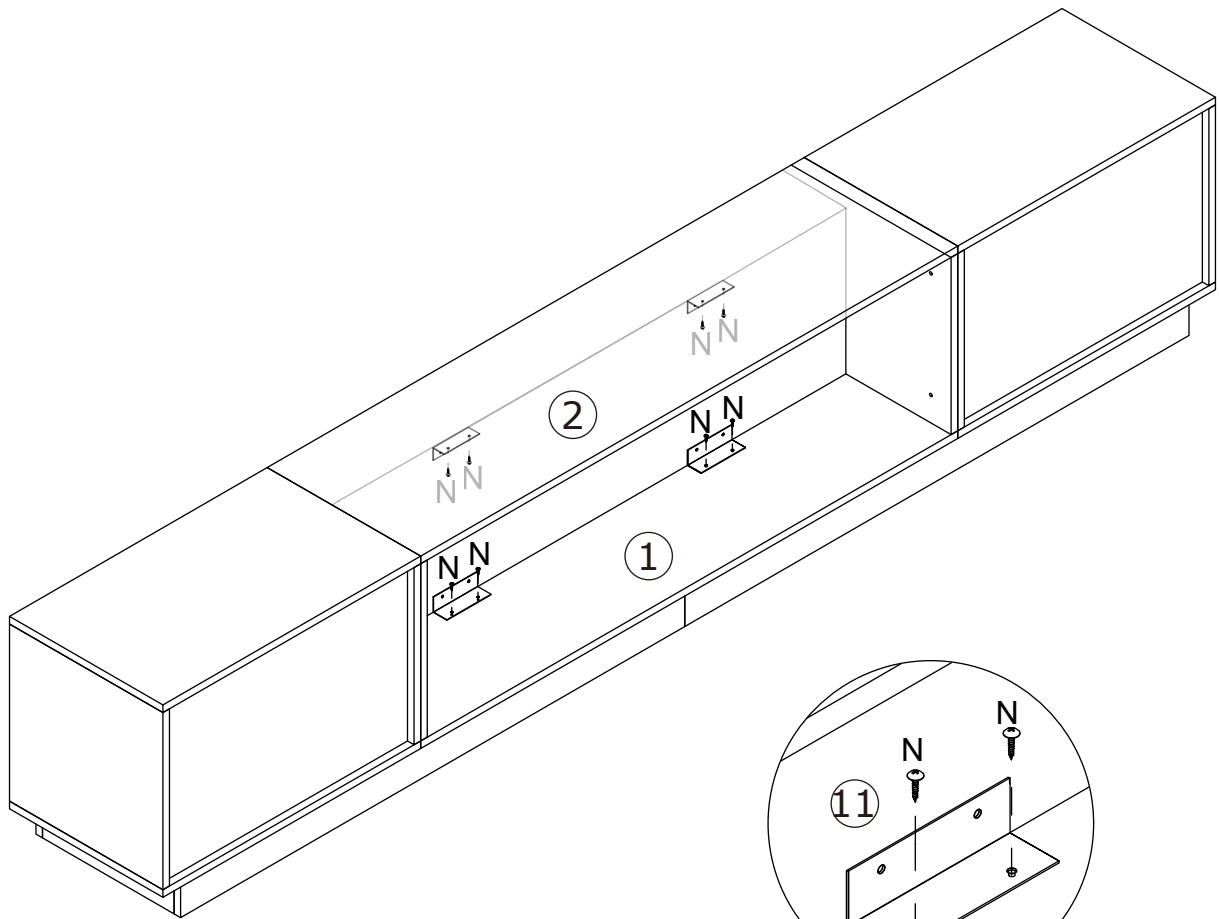

20

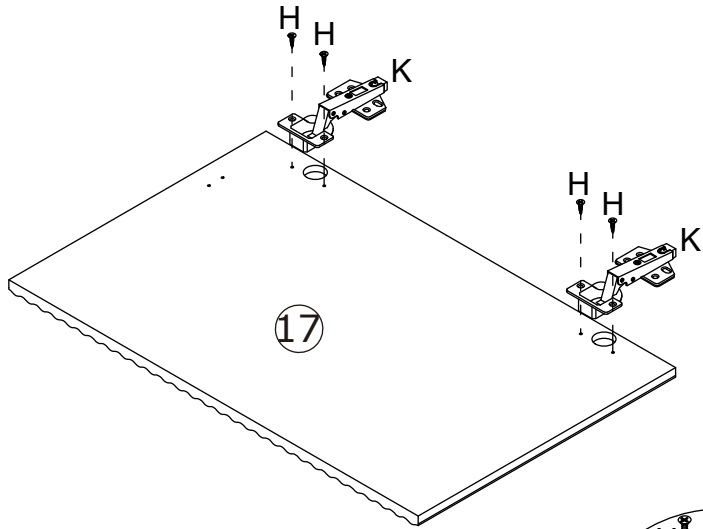

F  x5

G  x1

H  x12

K  x2

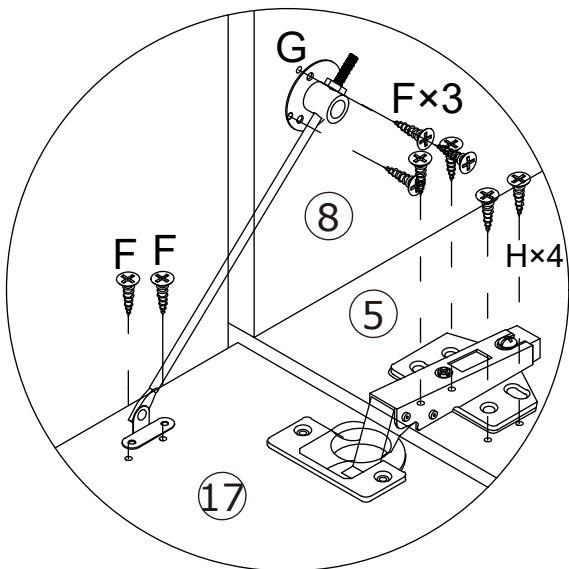
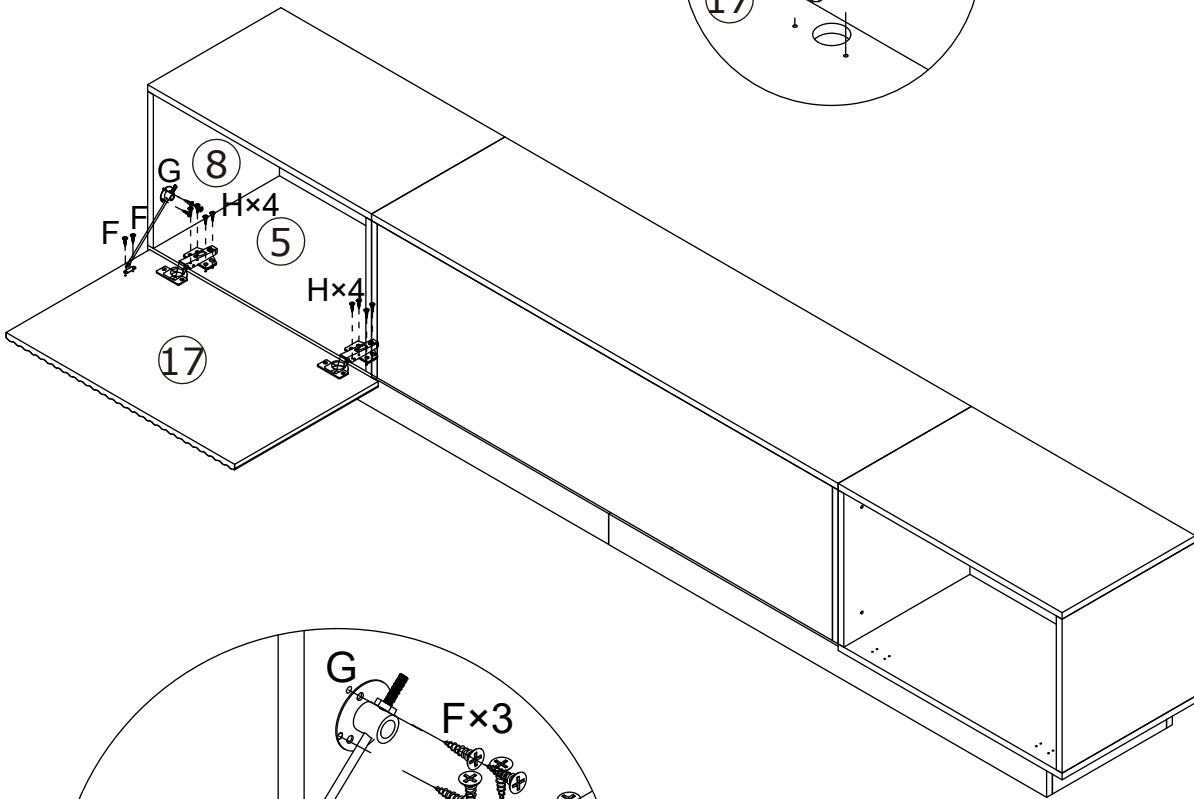
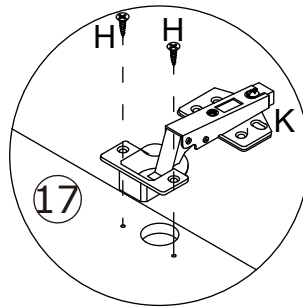

21

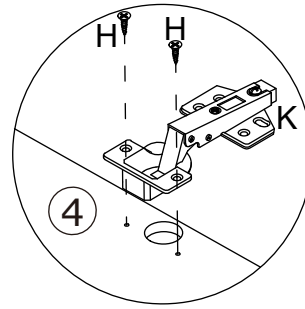
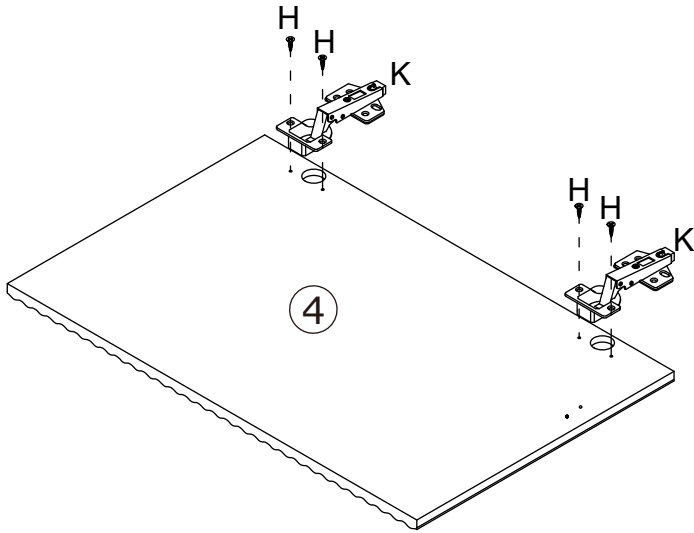

F  x5

G  x1

H  x12

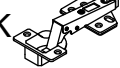
K  x2

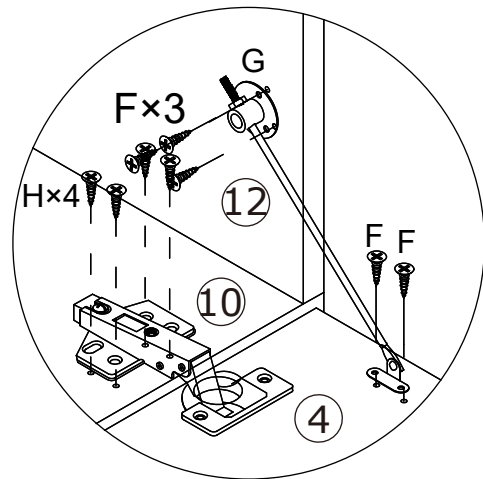
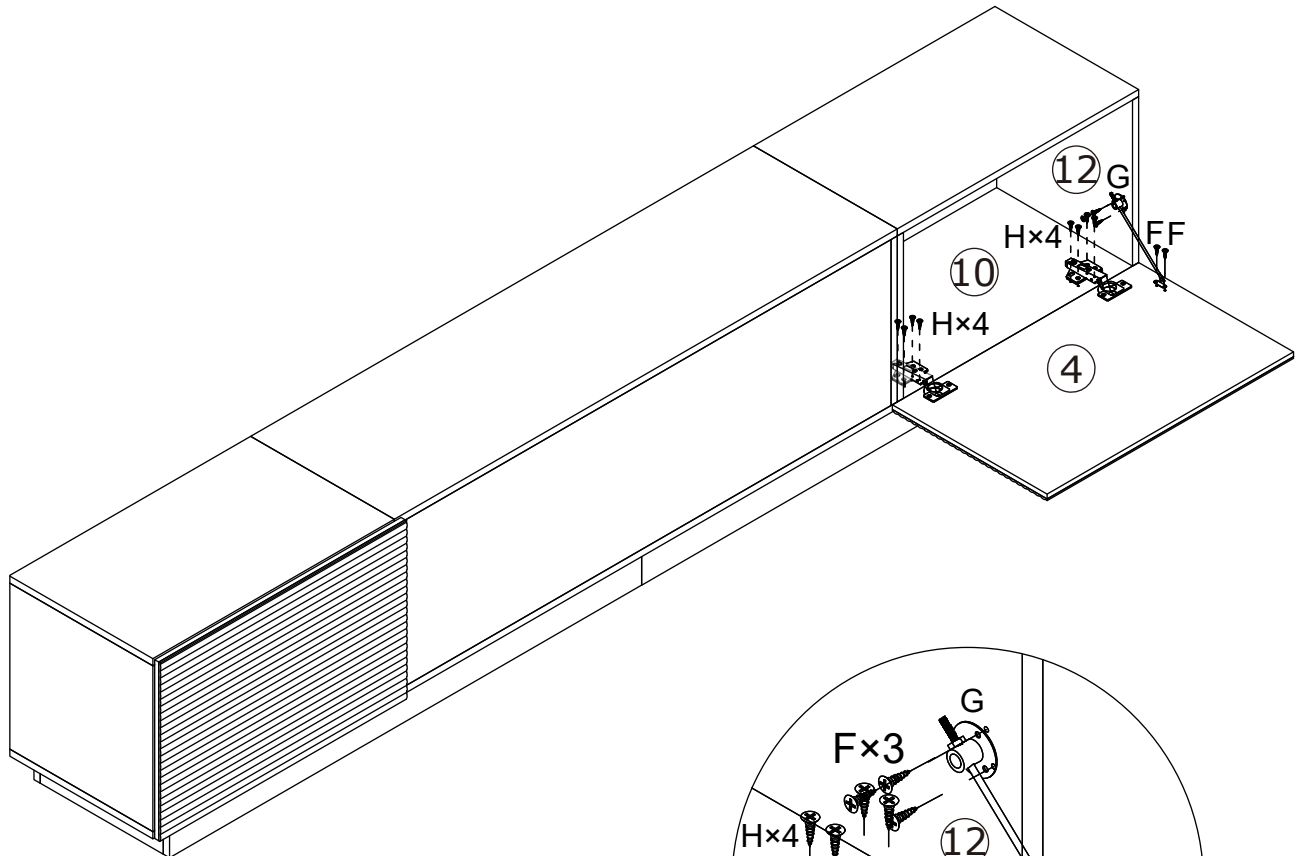

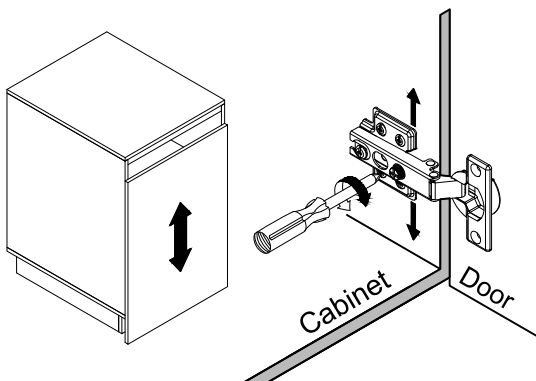
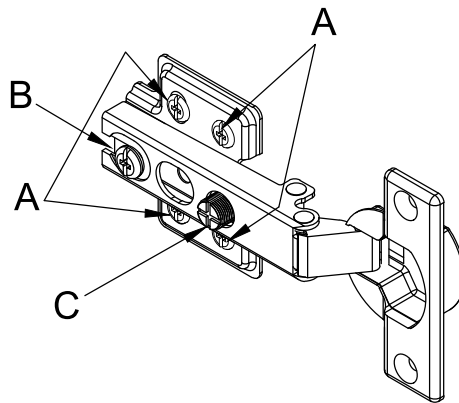

To adjust the vertical height.

Loosen the four screws "A" on both hinges. Two of them are usually in slotted holes which allows you to adjust up or down by a few mm. Then tighten back up.

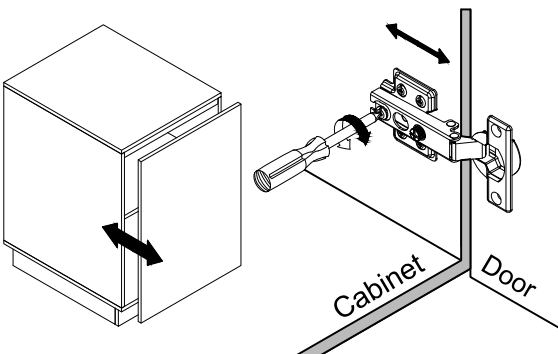

To adjust depth.

Loosen screw "B" and adjust door, if the door can not be adjusted, please loosen screw "C", then try again. Tighten screw "B" and "C".

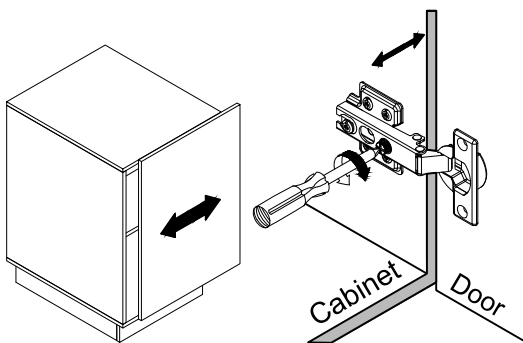

To adjust side ways.

Turning the screw "C" on BOTH hinges on each door.