

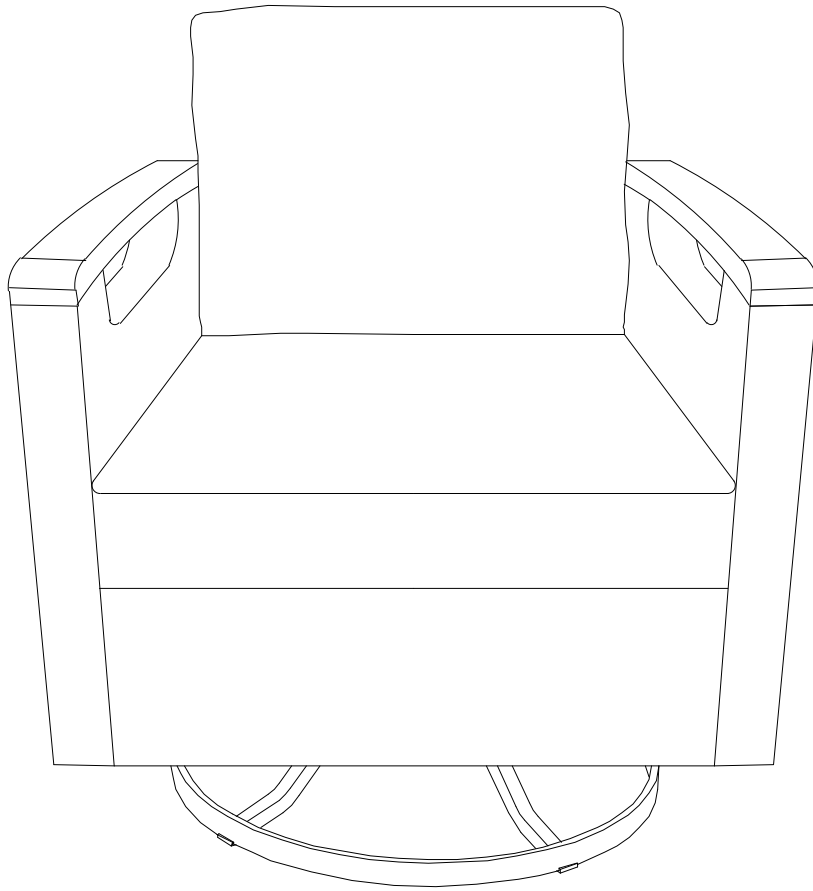









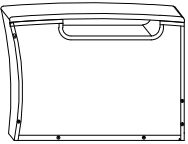
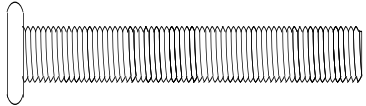
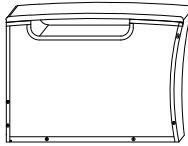

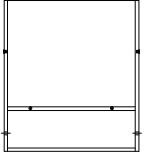

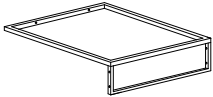
# Assembly Instructions

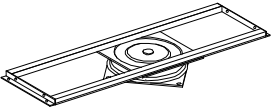

**\*Don't fully tighten all the bolts till the very end!**

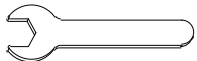
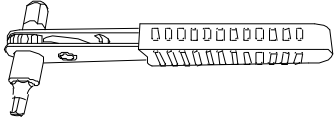
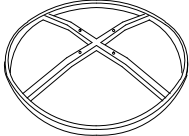
## PRE-ASSEMBLY PREPARATION:

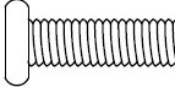
- Please read through the instructions before beginning assembly.
- Clear out the space for assembly and lay out all of the parts based on the Parts List, extra room will allow you to easily determine if all the pieces are present.
- Keep small parts and pieces away from children until fully assembled.

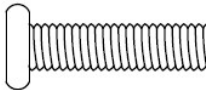
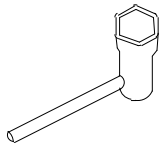
Part no.	Part	QTY	Image	Part no.	Part	QTY	Image
A1	Left arm	1		K	Bolt (M6*80mm)	2	
A2	Right arm	1		L	Bolt (M6*30mm)	4	
B	Back	1		M	Washer M6	34	
C	Seat	1		N	Spring washer M6	16	
D	Swivel plate with support bar	1		O	Nut M6	12	
E	U-shape fitting with swing arm	2		P	Allen wrench	1	
F	Wrench	1		Q	Ratchet wrench	1	
G	Base	1		R	Seat cushion	1	
H	Bolt (M6*35mm)	6		S	Back cushion	1	
I	Bolt (M6*40mm)	14					
J	Socket wrench	1					

**NOTE:** 1, Tool Q is spare wrench. If tool P can't work well, please try tool Q.  
2, Tool F is spare wrench. If tool J can't work well, please try tool F.

**Step 1:** Attach back B to arms A1 & A2 with 2pcs bolts K, 2pcs bolts H and 4pcs washers M, using Allen wrench P. Note: Don't fully tighten the bolts.

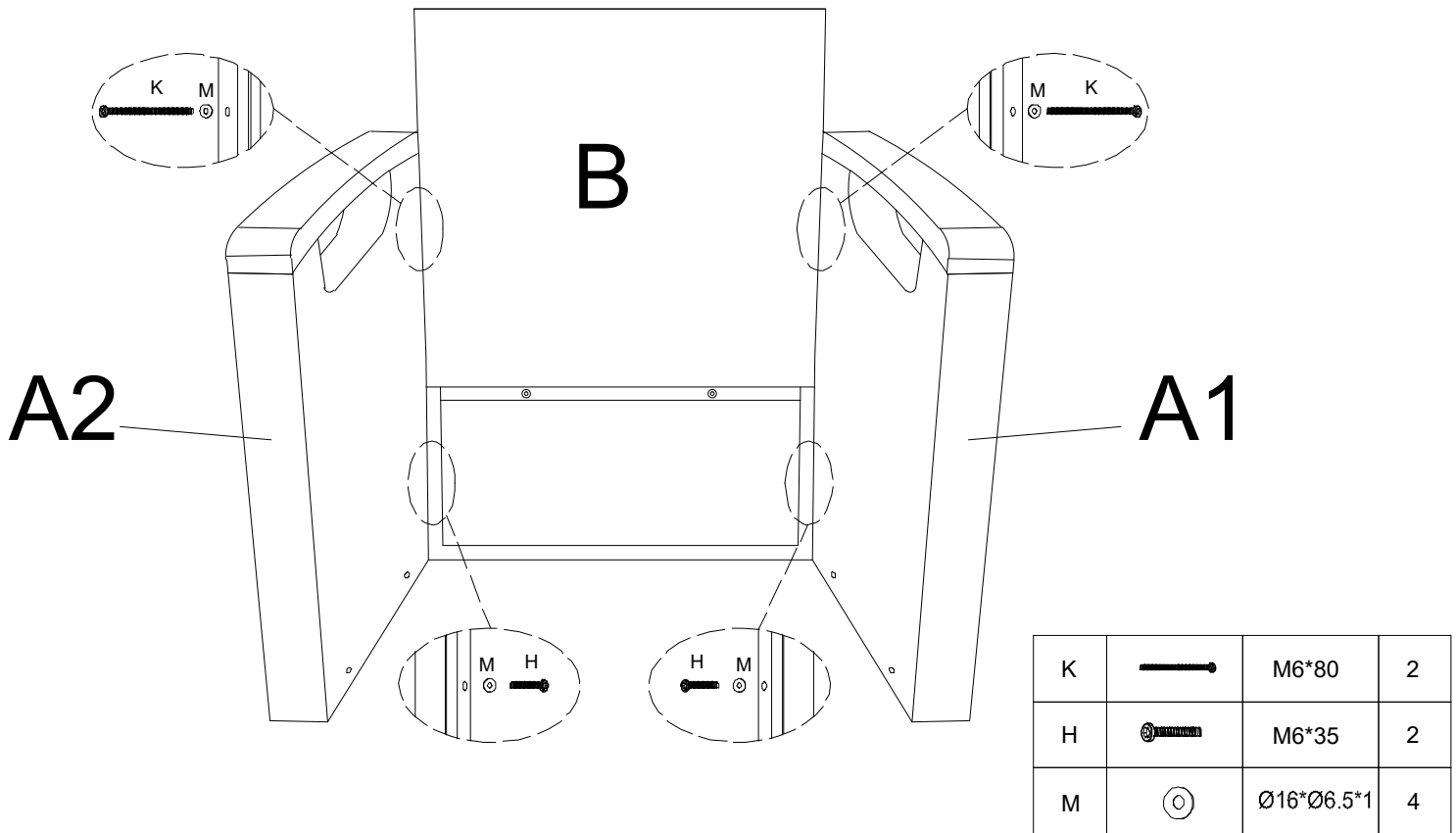



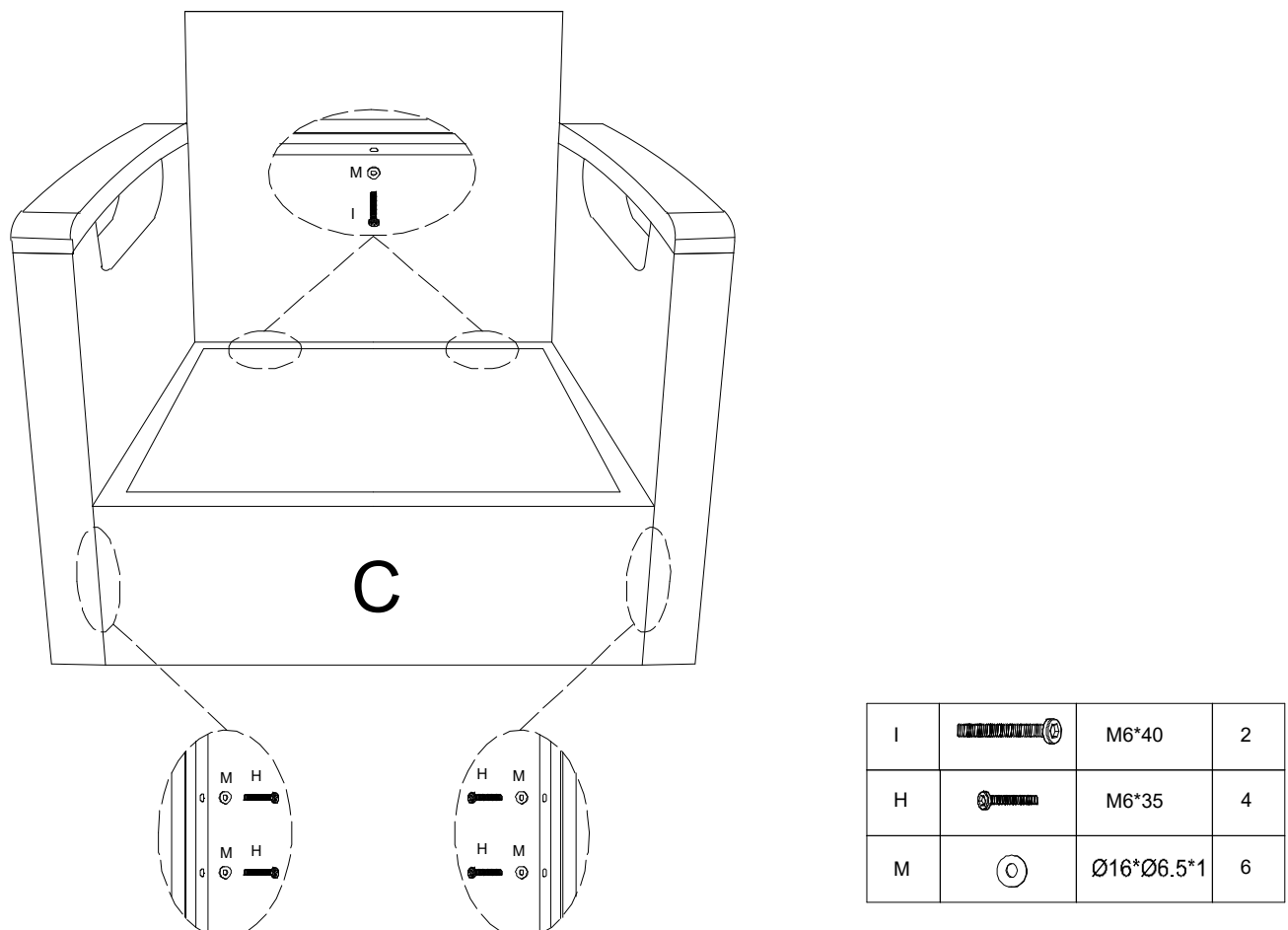

**Step 2:** Attach seat C to arms with 4pcs bolts H and 4pcs washers M, attach seat C to back with 2pcs bolts I and 2pcs washers M, using Allen wrench P. Note: Don't fully tighten the bolts.

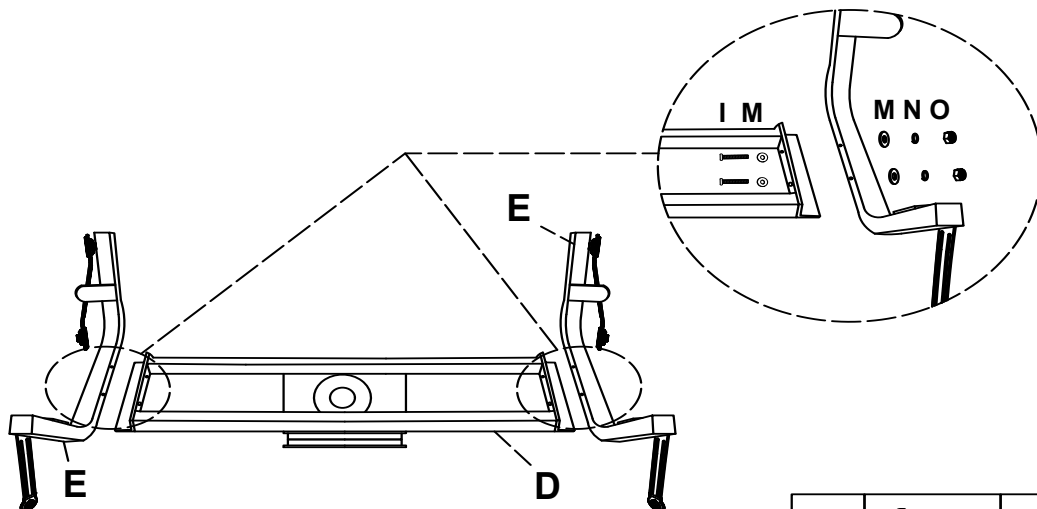





**Step 3:** From horizontal direction, attach 2pcs part E to part D with 4pcs bolts I, 8pcs washers M, 4pcs spring washers N, and 4pcs nuts O, using Allen wrench P and wrench J. Note: Don't fully tighten the bolts.

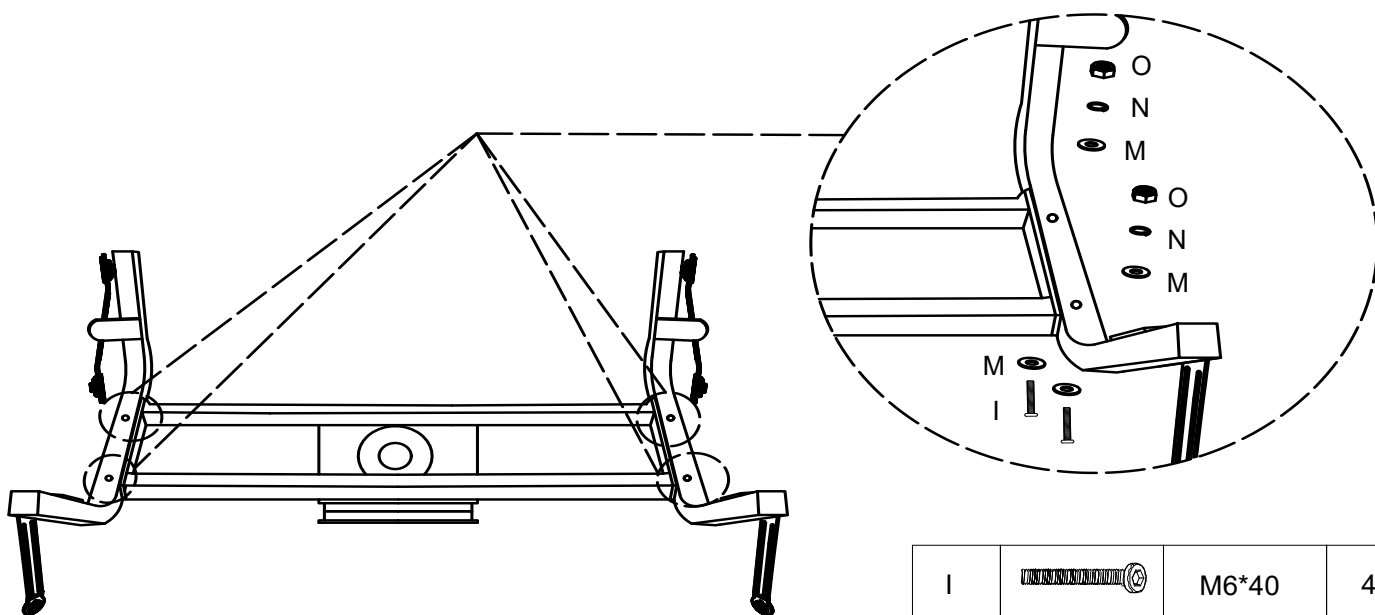

I		M6*40	4
M		Ø16*Ø6.5*1	8
N		M6	4
O		M6	4





**Step 4:** From vertical direction, attach 2pcs part E to part D with 4pcs bolts I, 8pcs washers M, 4pcs spring washers N, and 4pcs nuts O, using Allen wrench P and wrench J. Note: Don't fully tighten the bolts.

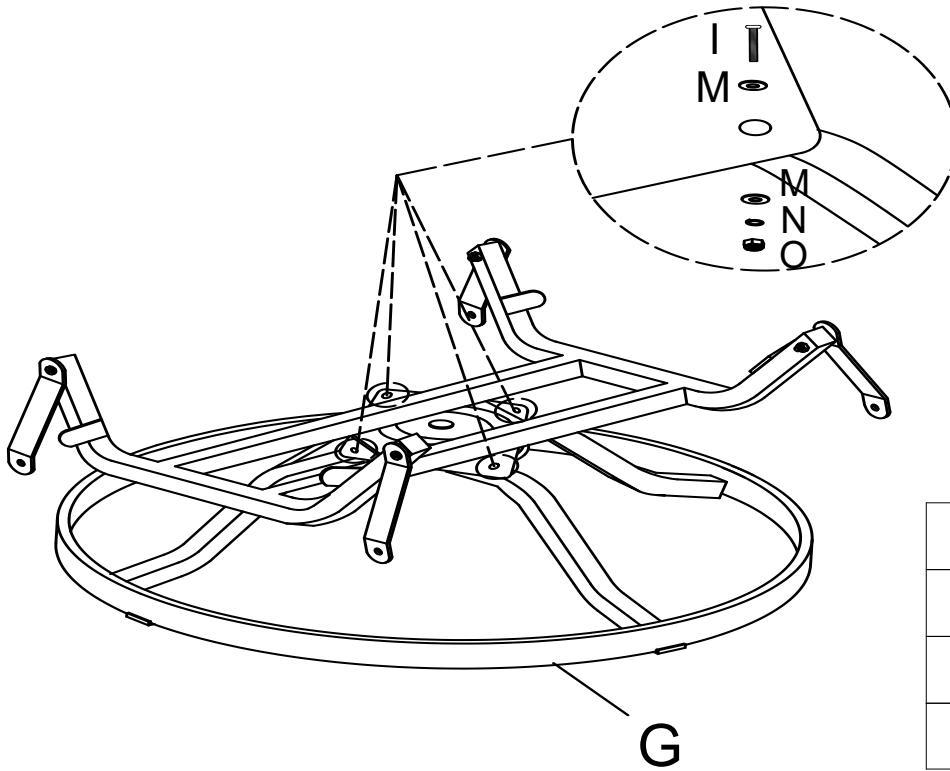

I		M6*40	4
M		Ø16*Ø6.5*1	8
N		M6	4
O		M6	4



**Step 5:** Attach swivel plate to part G with 4pcs bolts I, 8pcs washers M, 4pcs spring washers N, and 4pcs nuts O, using Allen wrench P and wrench J .Note: Don't fully tighten the bolts.

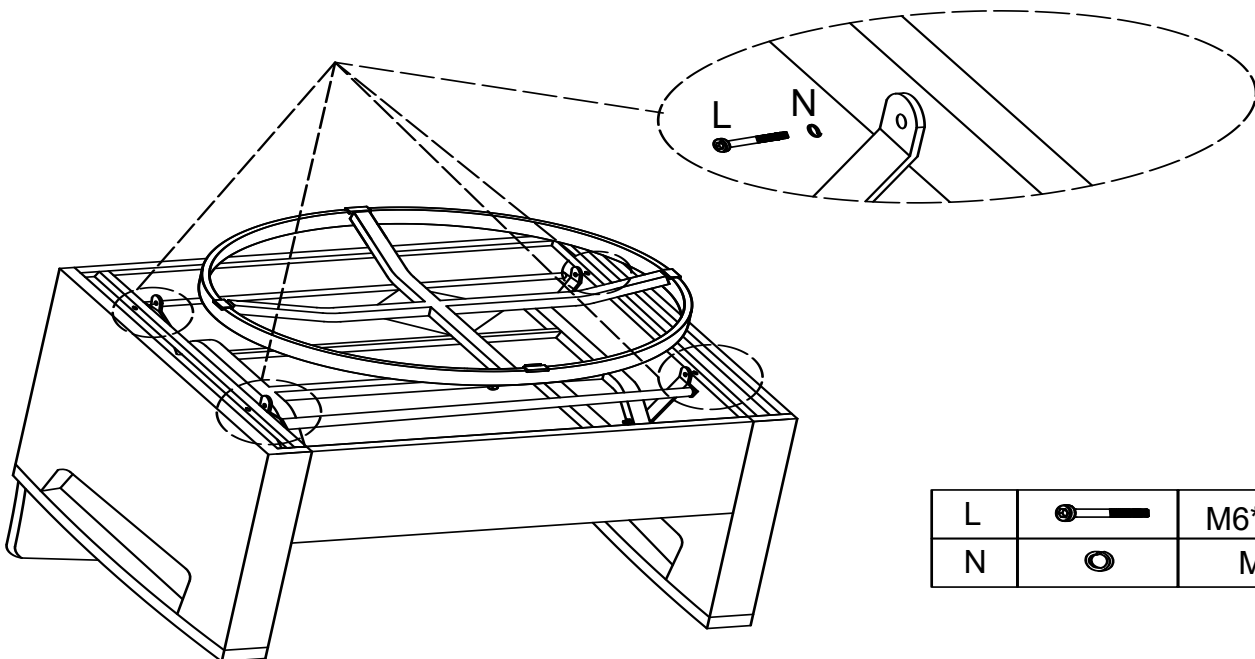

I		M6*40	4
M		Ø16*Ø6.5*1	8
N		M6	4
O		M6	4

**Step 6:** Attach swing arms to arms A1&A2 with 4pcs bolts L, 4pcs spring washers N, using Allen wrench P. Note: Please fully tighten all the bolts.

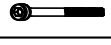

L		M6*30	4
N		M6	4

**Step 7:** Put back cushion S and seat cushion R onto the seat . Assembly is now complete and the product is ready for use.

