

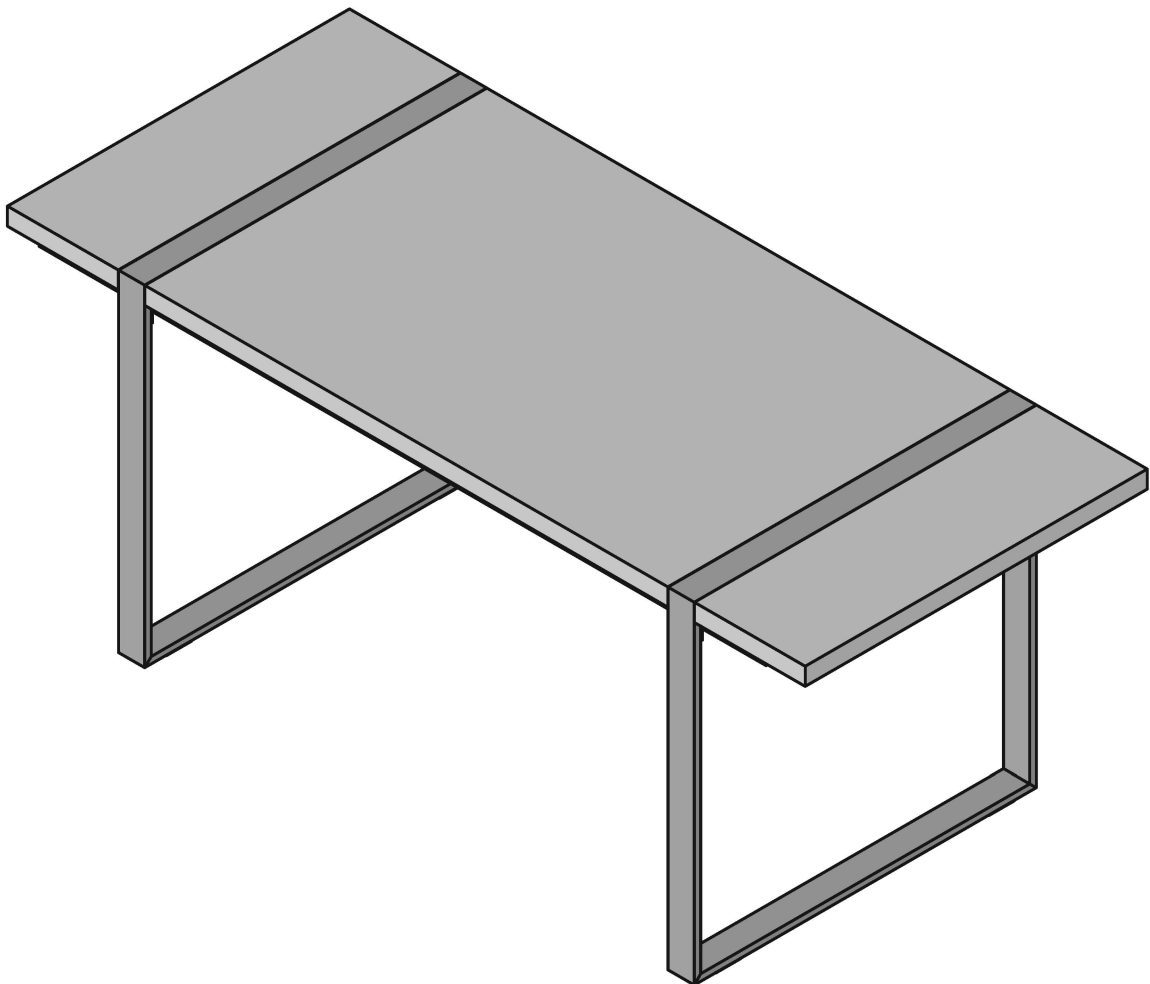

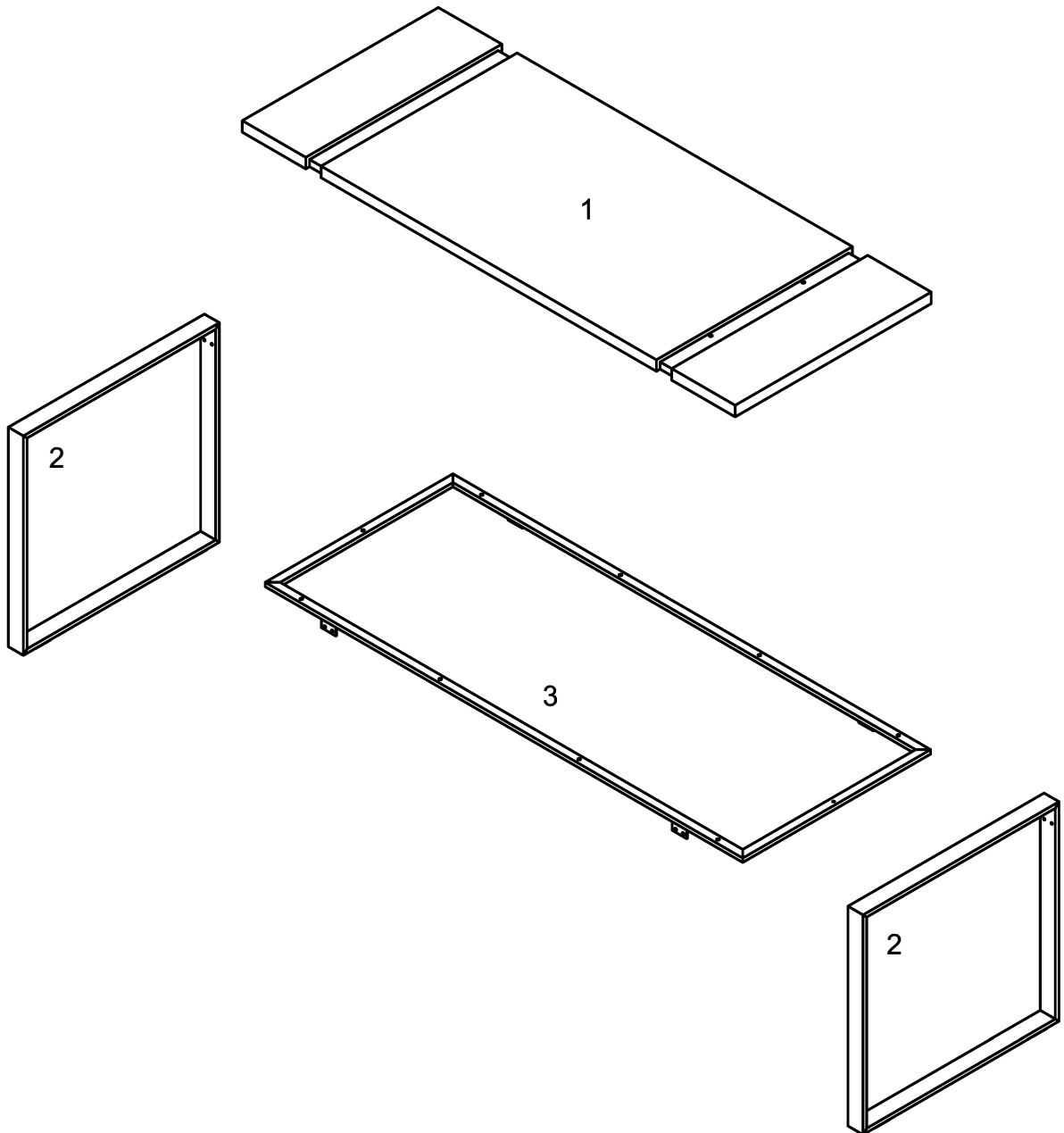





Assembly Instructions

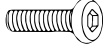

Parts List

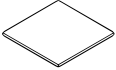

Hardware List

A		Ø1/4"*35mm	Bolt	4 pcs
B		Ø1/4"*25mm	Bolt	10 pcs
C		Ø1/4"*12mm	Bolt	8 pcs
D		Ø10.5*Ø6.5*2.0	Spring washer	14 pcs
E		Ø16*Ø6.8*1.0	Washer	14 pc
F		50*60mm	Place mat	4 pcs
G		M4*55mm	Wrench	1 pc

*The hardware quantities listed above are required for proper assembly.
Some extra hardware may also have been included.*

Step 1

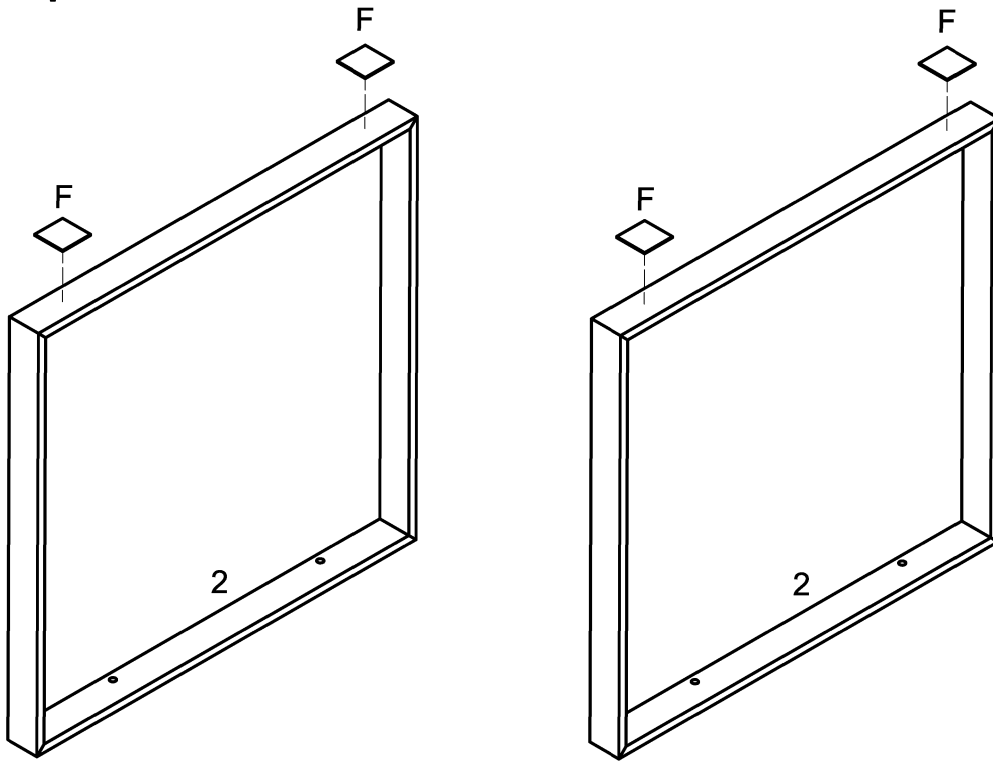

Stick the Place Mat (F) to the Side Frame (2) as per diagram.

Step 2

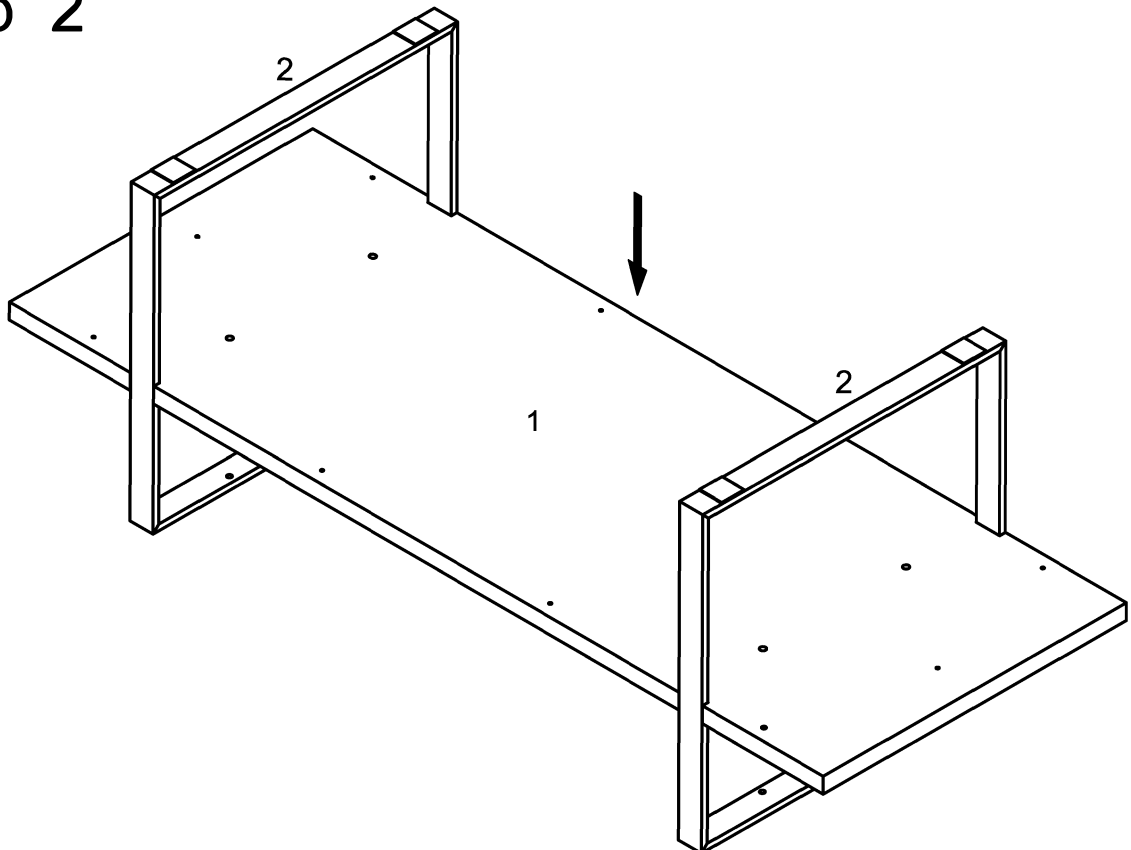

Insert the Top Panel (1) to the Side Frame (2) and push it down as per diagram.

Step 3

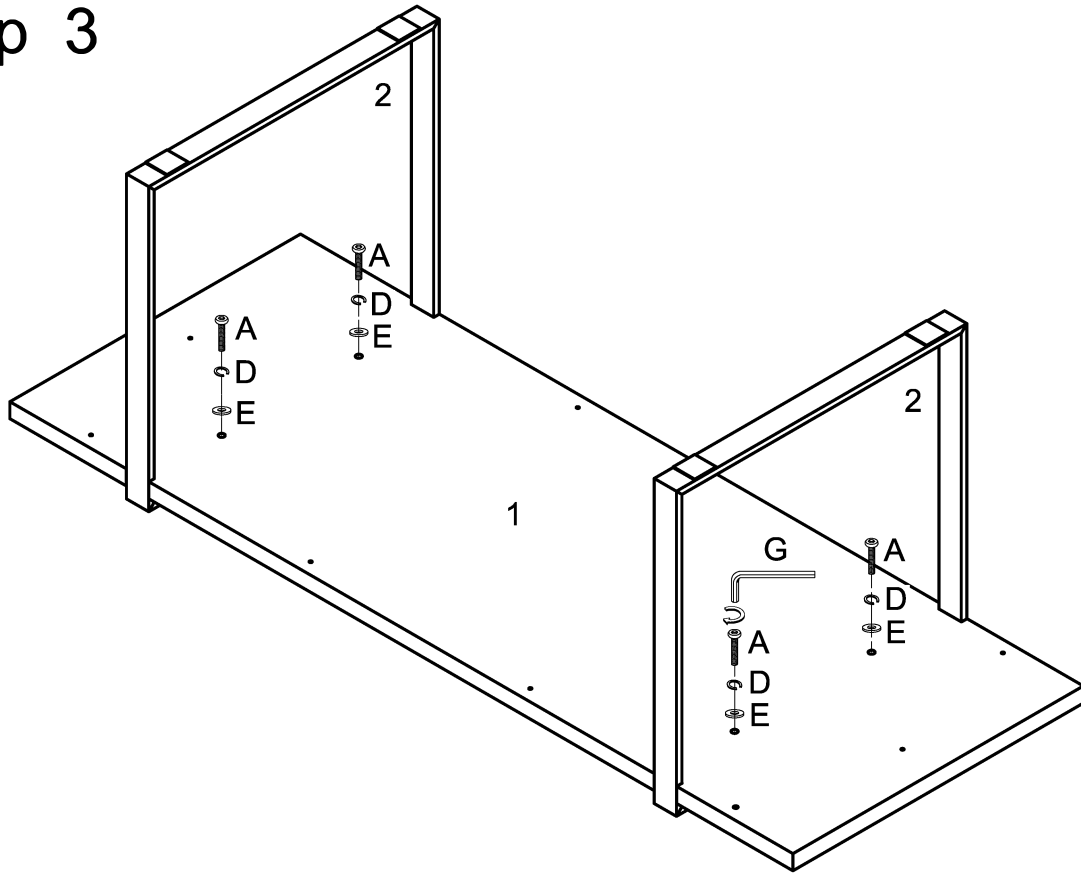

Use the Wrench (G), Bolt (A), Spring washer (D), Washer (E) to secure the Top Panel (1) to the Side Frame (2).

Step 4

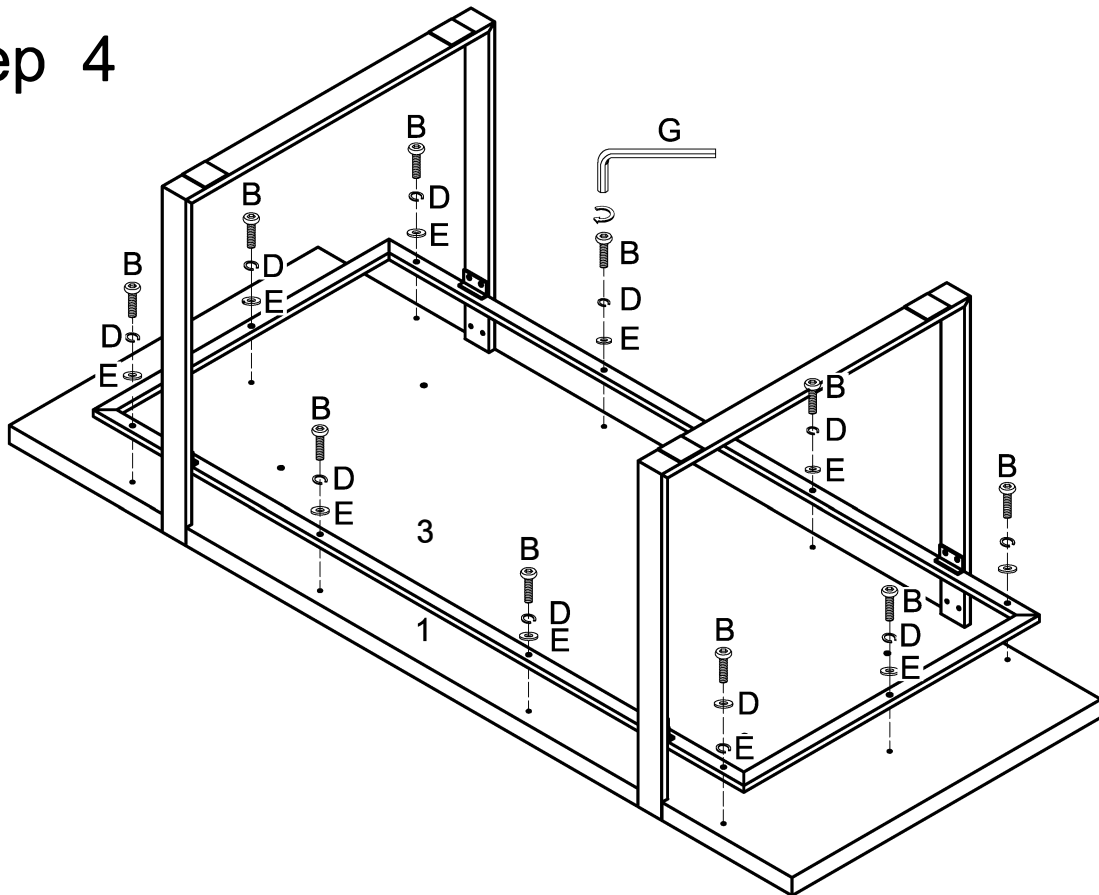

Insert the Bottom Frame (3) and use Wrench (G), Bolt (B), Spring washer (D), Washer (E) to secure the Top Panel (1).

Step 5

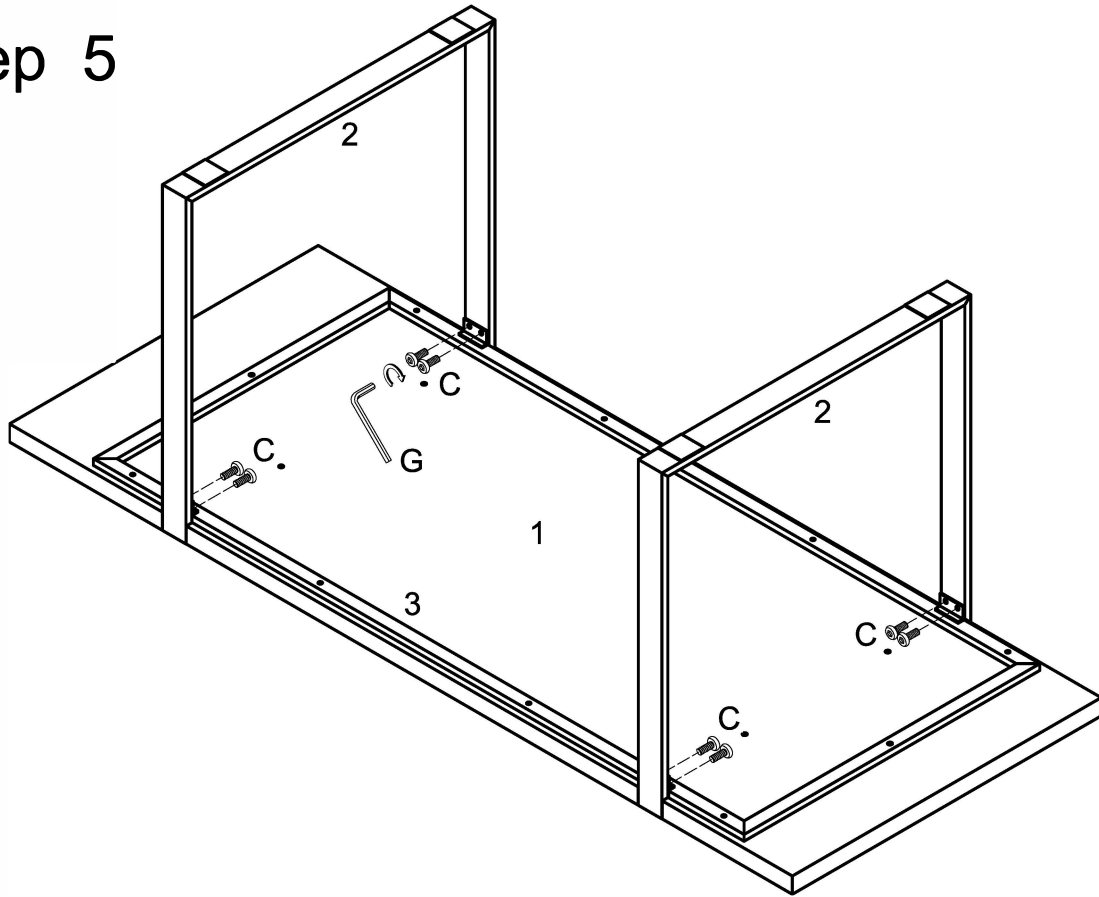

Use the Wrench (G), Bolt (C) to secure the Bottom Frame (3) to the Side Frame (2).

Step 6

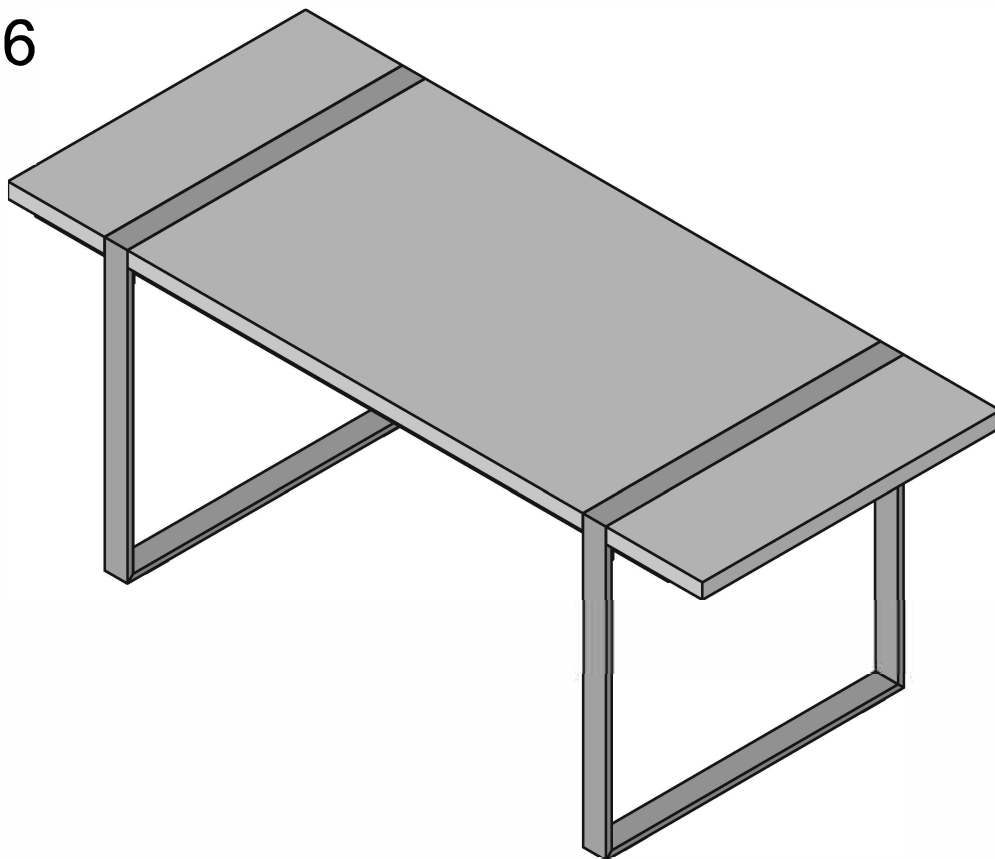

Final Assembly