











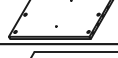

CARE AND MAINTENANCE

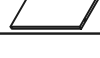
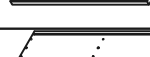
Spot clean using a mild water-free solvent. Only a professional cleaner should undertake a complete overall cleaning.
The use of steam or water-based cleaners may cause excessive shrinking or staining.

NOTICE

- * Please make sure that you have all parts indicated before you begin assembly of this item.
- * This item should be assembled on a soft surface to prevent scratching the finish during assembly.
- * This item may require periodic tightening.

Part List and Hardware List





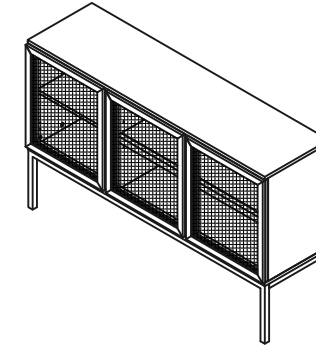







PIECE	DESCRIPTION	PICTURE	QUANTITY
A	TOP PANEL		1X
B	LEFT PANEL		1X
C	RIGHT PANEL		1X
D	DIVIDER		1X
E	ADJUSTABLE SHELF		1X
F	SHELF		1X
G	RAIL ADJUSTABLE SHELF		1X
H	BOTTOM PANEL		1X
I	RAIL		2X
J	BACK PANEL		2X
K	LEG FRAME		2X
L	SIDE FRAME		2X
M	CENTER FRAME		2X
N	DOOR		3X

Product Dimensions: 54"W x 15"D x 33"H



WEIGHT CAPACITY :
TOP : 50 LBS
SHELF : 15 LBS

**WARNING: DO NOT OVER TORQUE
BOLTS/SCREWS**

PIECE	DESCRIPTION	PICTURE	QTY
1	45 MM BOLT	M6x45mm 	8X
2	35 MM BOLT	M6x35mm 	8X
3	20 MM BOLT	M6x20mm 	4X
4	1/2" ROUND HEAD SCREW	M3x13mm 	30X
5	5/8" FLAT HEAD SCREW	M3x16mm 	12X
6	1/2" FLAT HEAD SCREW	M2x13mm 	3X
7	CAMBOLT		30X
8	CAMLOCK		30X
9	HINGE		6X
10	SHELF SUPPORT PIN		4X
11	DOWEL	Ø 8x28mm 	12X
12	DOWEL	Ø 6x30mm 	4X
13	MAGNET		3X
14	PLATE MAGNET		3X
15	PLASTIC STRIP		1X
16	WEDGE		12X
17	ALLEN KEY		1X

PREPARATION

Before beginning assembly of product, make sure all parts are present. Compare parts with package contents list and hardware contents list.

If any part is missing or damaged, do not attempt to assemble the product.

Estimated Assembly Time: 60 minutes.

Tools Required for Assembly : Phillips Screwdriver

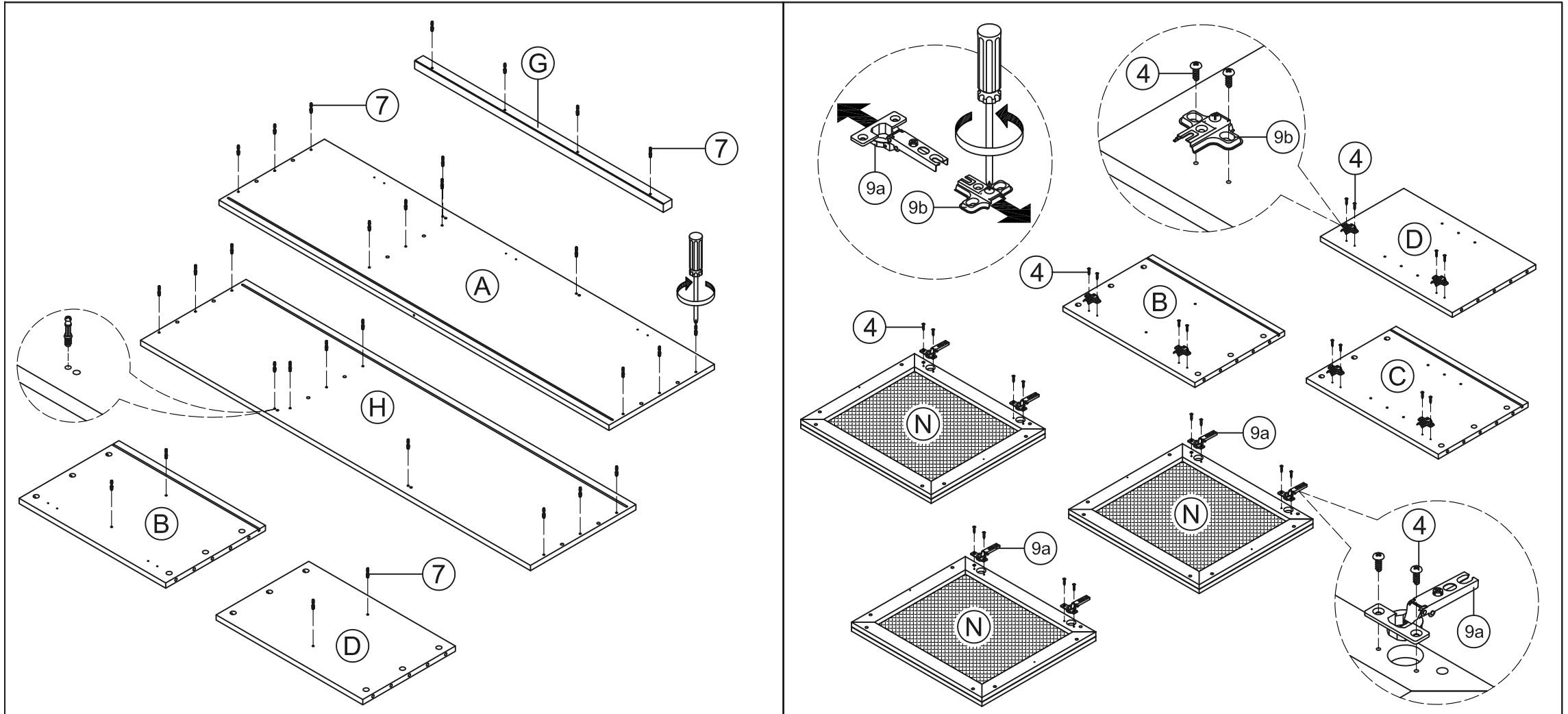

STEP 1 ATTACH CAMBOLTS TO TOP PANEL, LEFT PANEL, DIVIDER, RAIL ADJUSTABLE SHELF AND BOTTOM PANEL.

STEP 2 DETACH THE HINGE FROM THE BASE. ATTACH HINGE BASES TO LEFT AND RIGHT PANELS AND DIVIDER USING 1/2" ROUND HEAD SCREWS. ATTACH HINGES TO DOORS USING 1/2" ROUND HEAD SCREWS.

PREPARATION

Before beginning assembly of product, make sure all parts are present. Compare parts with package contents list and hardware contents list.

If any part is missing or damaged, do not attempt to assemble the product.

Estimated Assembly Time: 60 minutes.

Tools Required for Assembly : Phillips Screwdriver

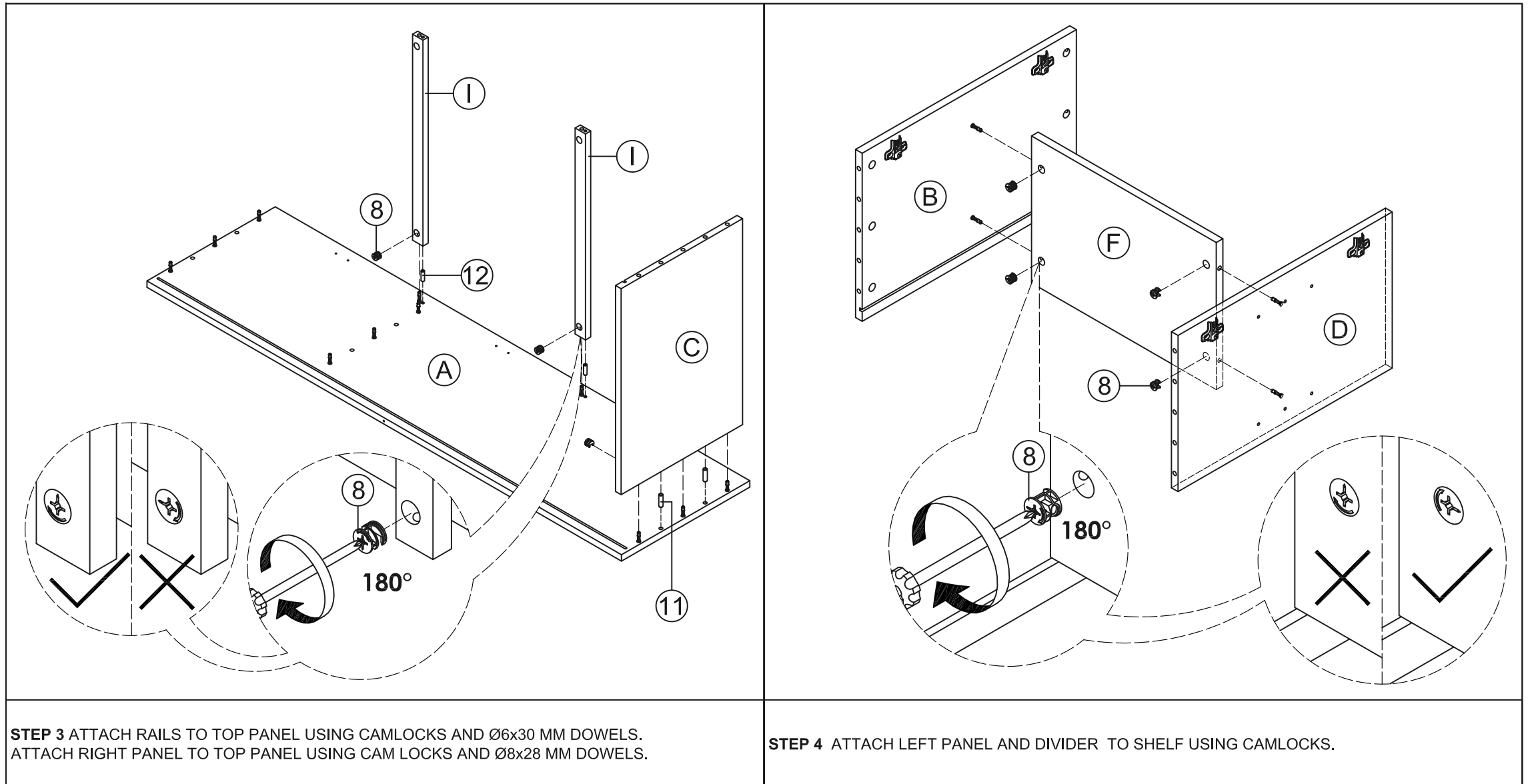

PREPARATION

Before beginning assembly of product, make sure all parts are present. Compare parts with package contents list and hardware contents list.

If any part is missing or damaged, do not attempt to assemble the product.

Estimated Assembly Time: 60 minutes.

Tools Required for Assembly : Phillips Screwdriver

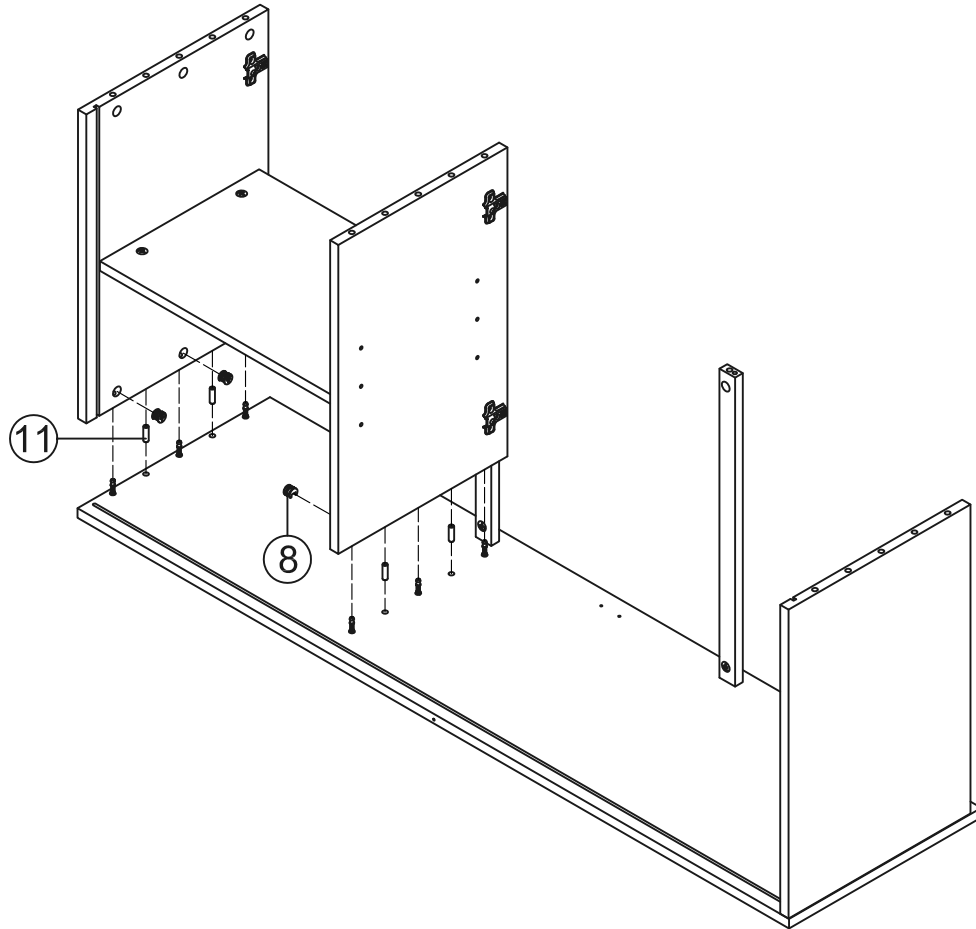

STEP 5 ATTACH UNIT FROM STEP 4 TO UNIT FROM STEP 3 USING CAMLOCKS AND Ø8X28 MM DOWELS.

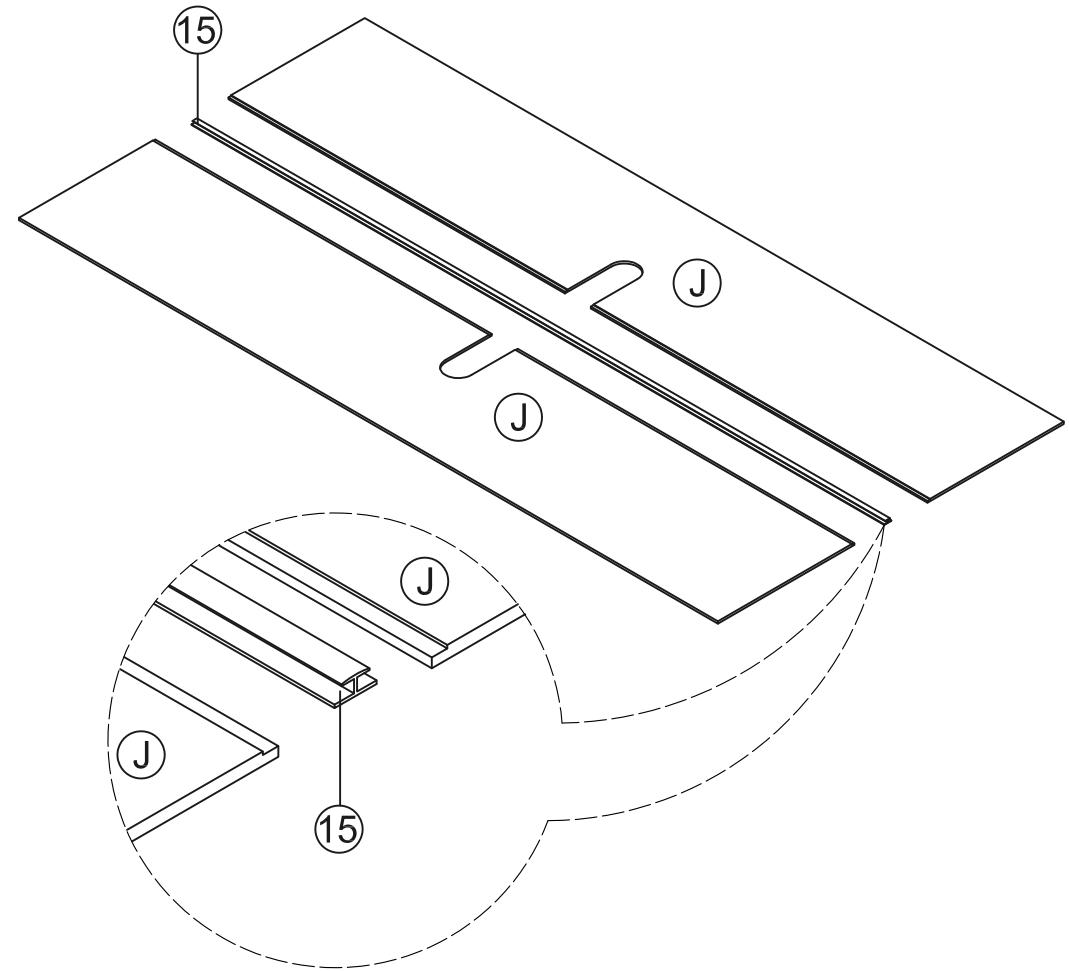

STEP 6 JOIN BACK PANELS USING PLASTIC STRIP.

PREPARATION

Before beginning assembly of product, make sure all parts are present. Compare parts with package contents list and hardware contents list.

If any part is missing or damaged, do not attempt to assemble the product.

Estimated Assembly Time: 60 minutes.

Tools Required for Assembly : Phillips Screwdriver

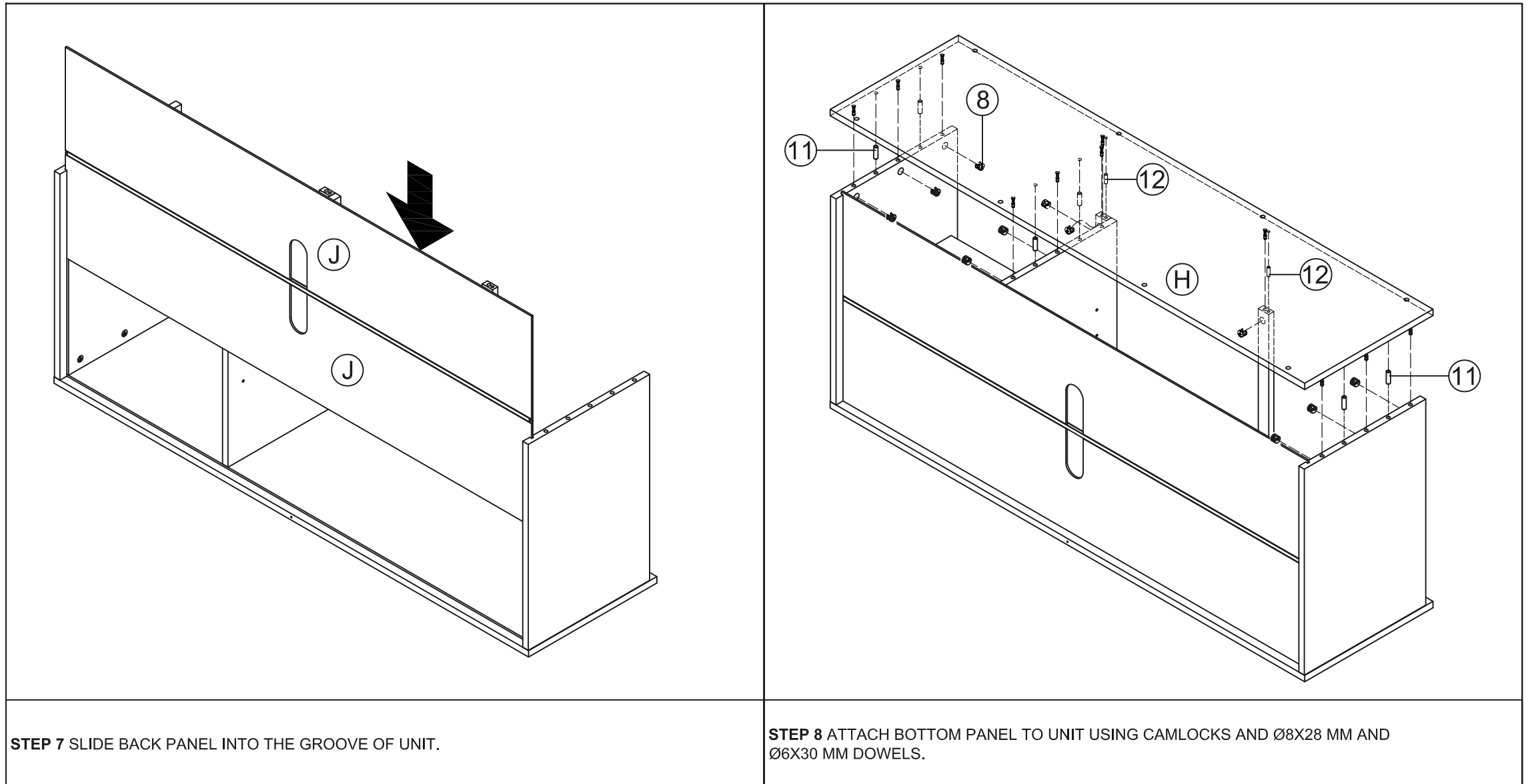

PREPARATION

Before beginning assembly of product, make sure all parts are present. Compare parts with package contents list and hardware contents list.

If any part is missing or damaged, do not attempt to assemble the product.

Estimated Assembly Time: 60 minutes.

Tools Required for Assembly : Phillips Screwdriver

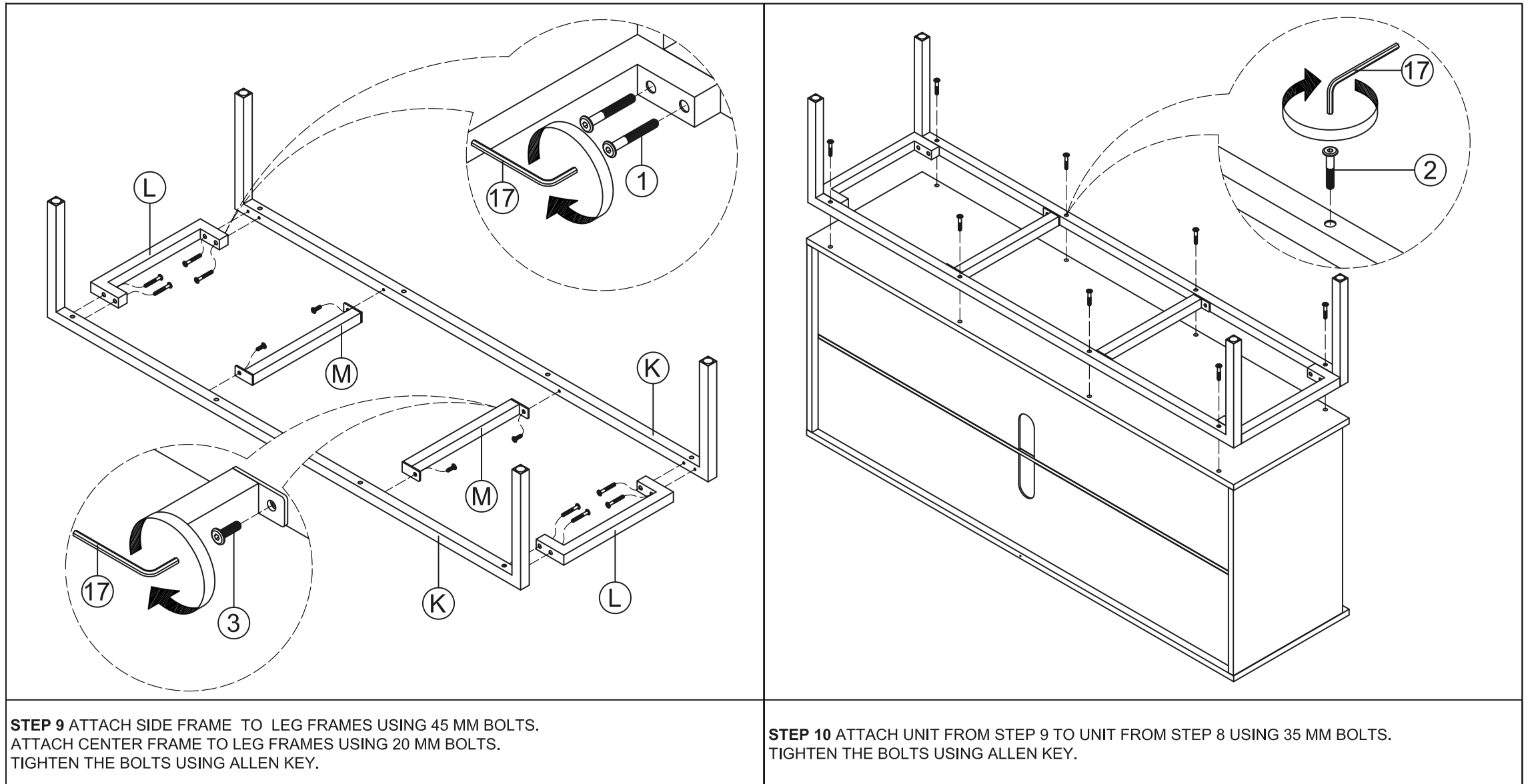

PREPARATION

Before beginning assembly of product, make sure all parts are present. Compare parts with package contents list and hardware contents list.

If any part is missing or damaged, do not attempt to assemble the product.

Estimated Assembly Time: 60 minutes.

Tools Required for Assembly : Phillips Screwdriver

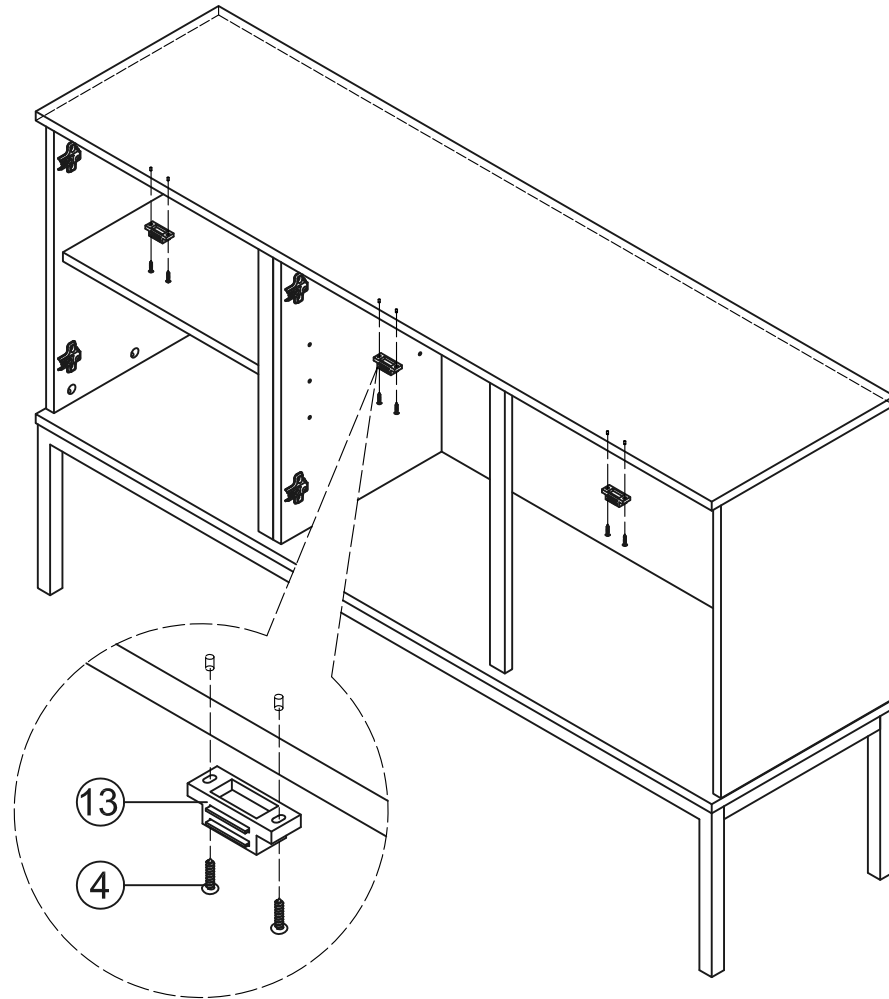

STEP 11 ATTACH MAGNETS TO UNIT USING 1/2" ROUND HEAD SCREWS.

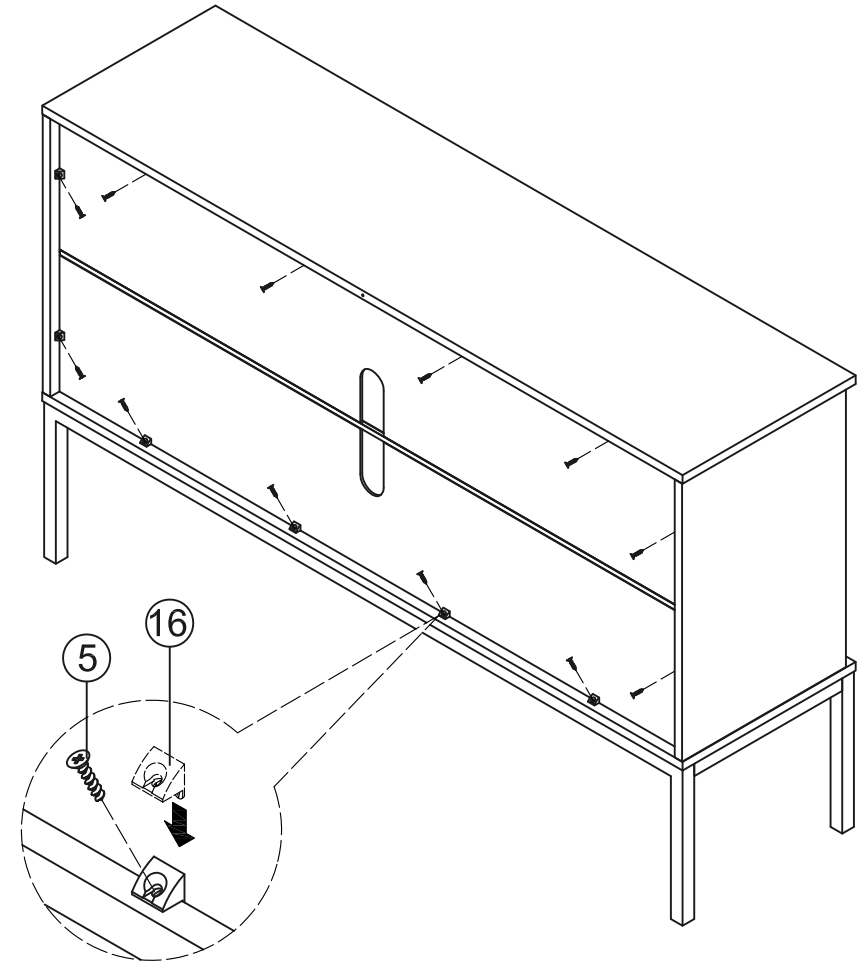

STEP 12 ATTACH WEDGES TO UNIT USING 5/8" FLAT HEAD SCREWS.

PREPARATION

Before beginning assembly of product, make sure all parts are present. Compare parts with package contents list and hardware contents list.

If any part is missing or damaged, do not attempt to assemble the product.

Estimated Assembly Time: 60 minutes.

Tools Required for Assembly : Phillips Screwdriver

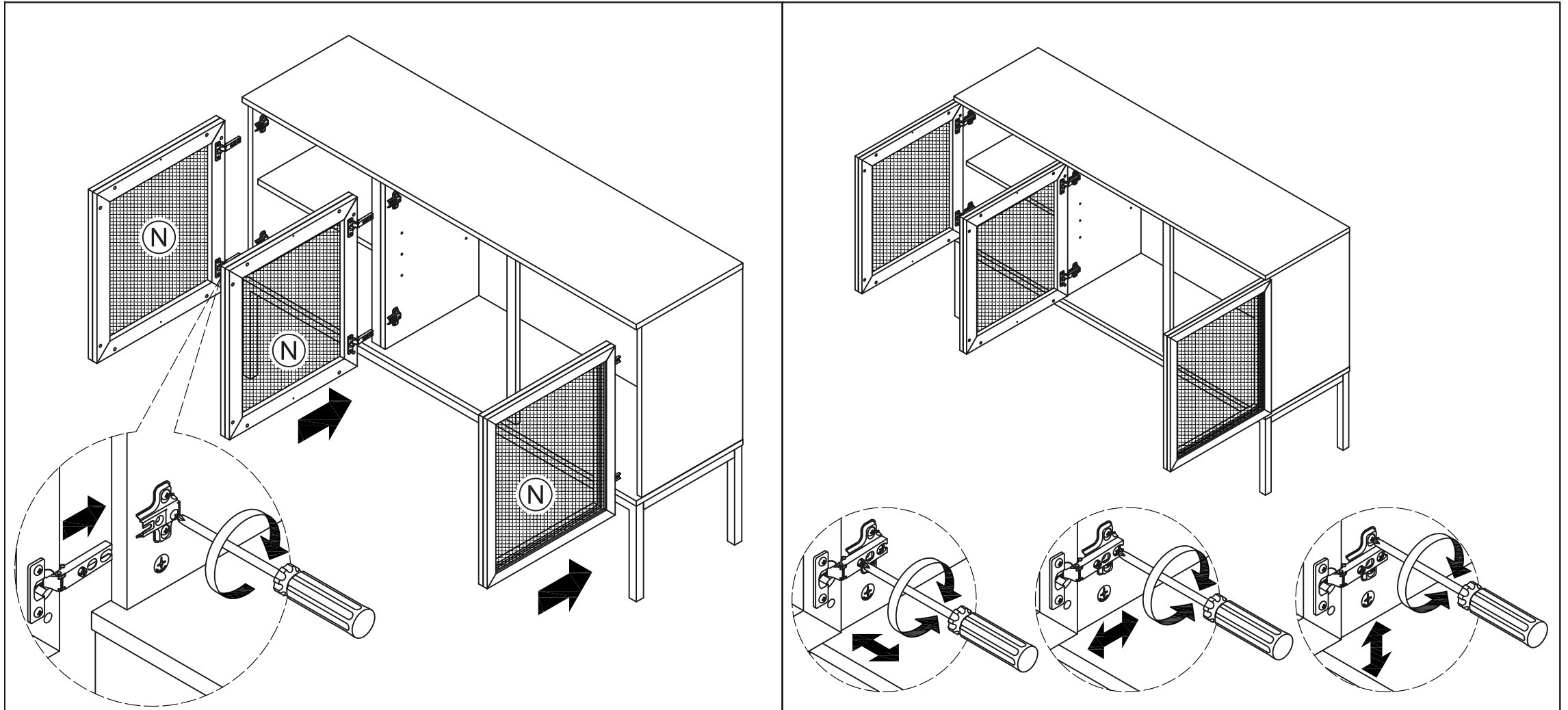

STEP 13 ATTACH DOORS TO UNIT.

STEP 14 FRONT MIDDLE SCREW ON HINGE WILL ADJUST YOUR DOOR TO THE LEFT AND RIGHT. BACK MIDDLE SCREW ON HINGE WILL ADJUST YOUR DOOR FORWARD AND BACKWARD. SCREW ON HINGE BASE WILL ADJUST YOUR DOOR UP AND DOWN.

PREPARATION

Before beginning assembly of product, make sure all parts are present. Compare parts with package contents list and hardware contents list.

If any part is missing or damaged, do not attempt to assemble the product.

Estimated Assembly Time: 60 minutes.

Tools Required for Assembly : Phillips Screwdriver

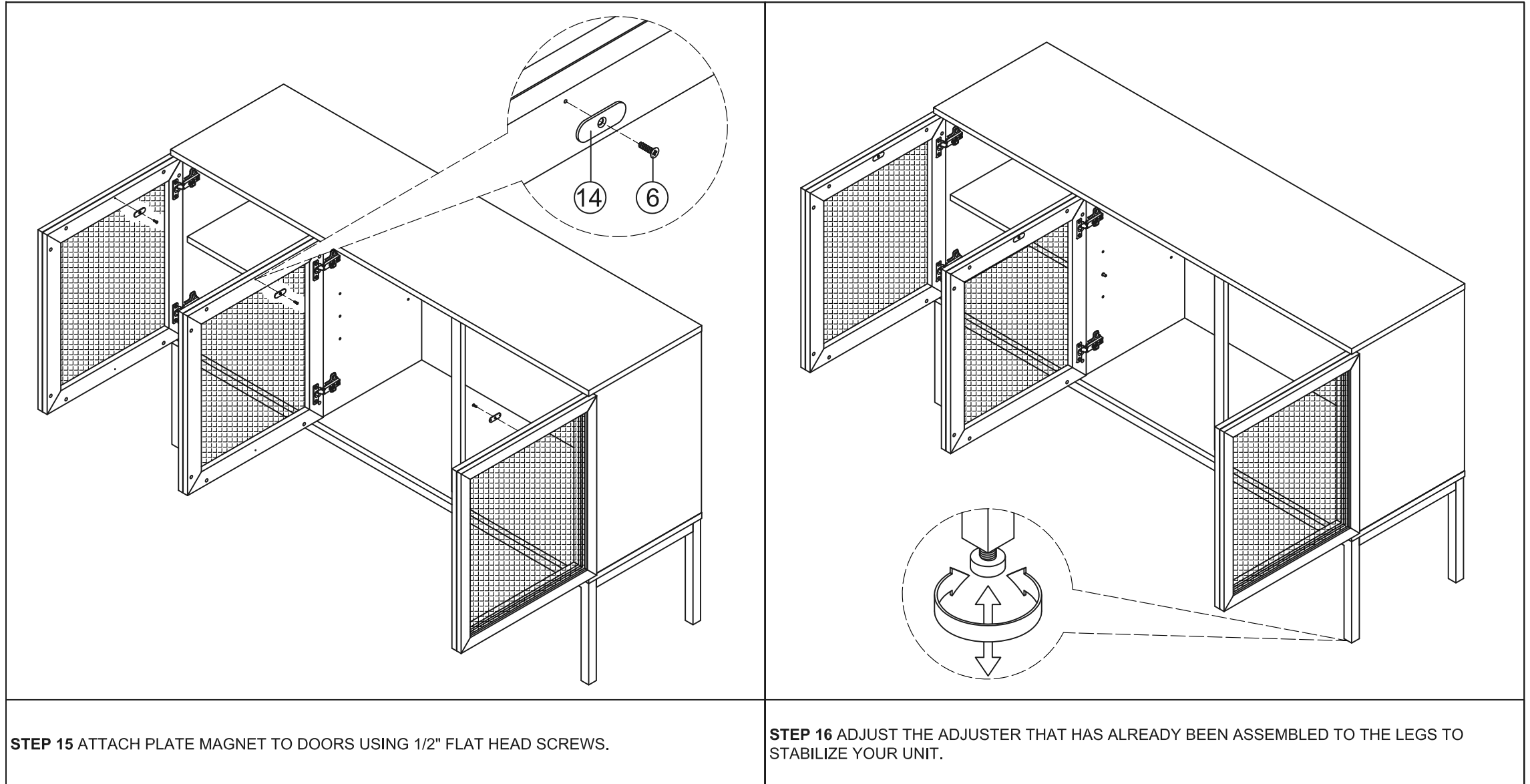

PREPARATION

Before beginning assembly of product, make sure all parts are present. Compare parts with package contents list and hardware contents list.

If any part is missing or damaged, do not attempt to assemble the product.

Estimated Assembly Time: 60 minutes.

Tools Required for Assembly : Phillips Screwdriver

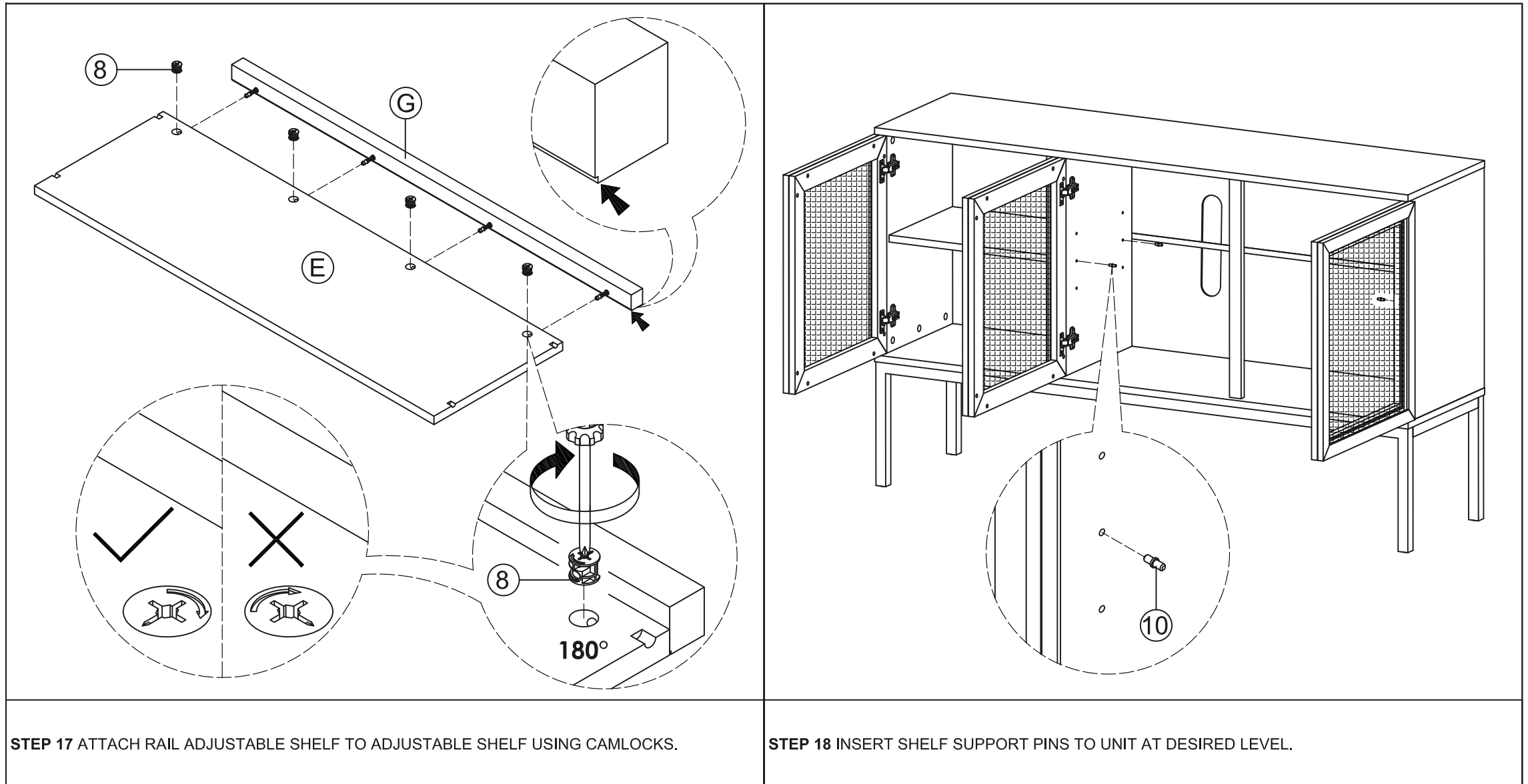

PREPARATION

Before beginning assembly of product, make sure all parts are present. Compare parts with package contents list and hardware contents list.

If any part is missing or damaged, do not attempt to assemble the product.

Estimated Assembly Time: 60 minutes.

Tools Required for Assembly : Phillips Screwdriver

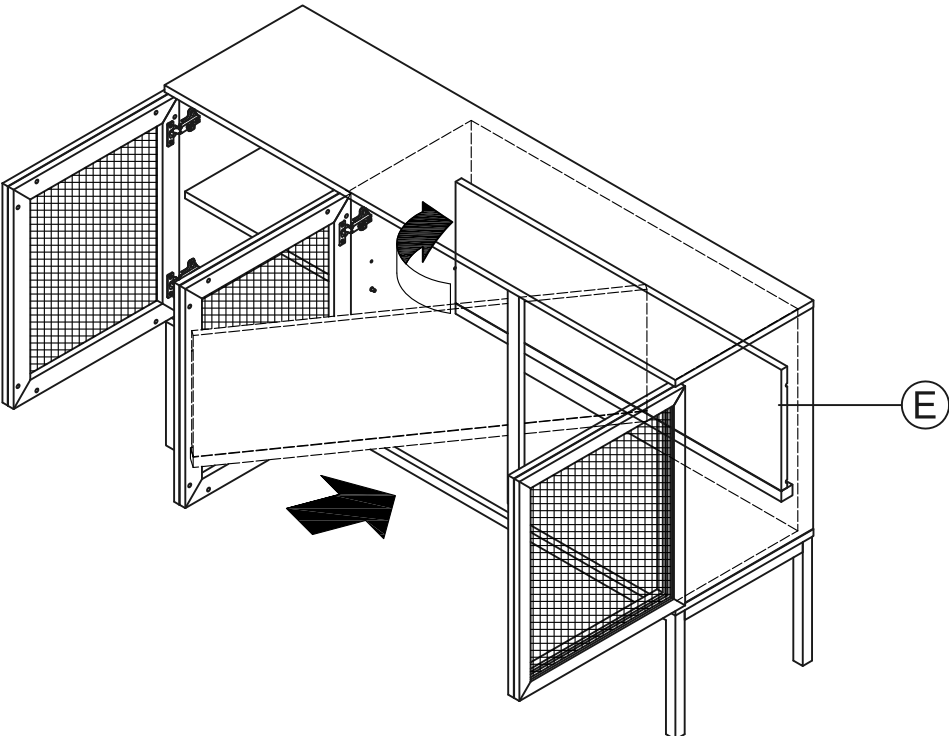
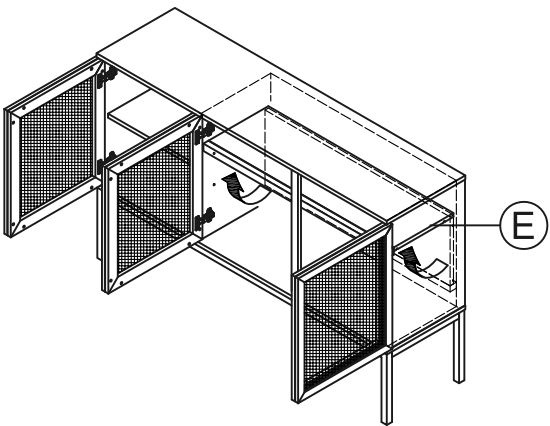
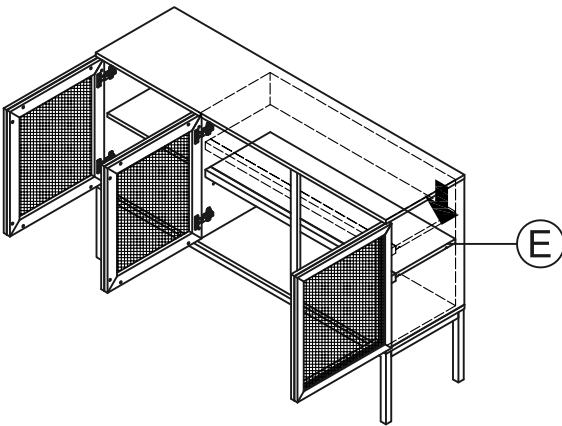
<p>1</p>  <p>STEP 19.1 INSERT ADJUSTABLE SHELF AT AN ANGLE AND ALIGN THEM WITH UNIT.</p>	<p>2</p>  <p>STEP 19.2 ROTATE 90° ADJUSTABLE SHELF.</p>
	<p>3</p>  <p>STEP 19.3 PLACE ADJUSTABLE SHELF ON THE SUPPORT PINS.</p>