

# **ALUMINUM PATIO FURNITURE COFFEE TABLE**

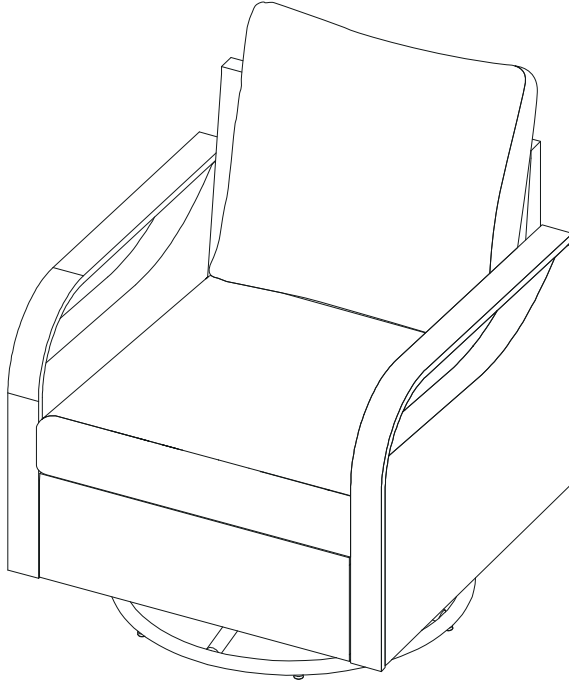

# NOTICE

---



**Please keep these instructions for future reference.**

**Dear Customer**

- Thank you for your purchase. When you receive the product, please make sure that all the parts are intact. Then follow the entire installation instructions to install!
- Please install under viewing the instruction, if you have some problem below, contact our customer service first.
  - A . The outer box is damaged
  - B . The product is damaged / bent / cracked while you open the box
  - C . The parts / accessories / assembly tools are missing
  - D . The instructions are not clear and can not be referred
  - E . The product has functional problems
  - F . Other aspects that you are not satisfied with

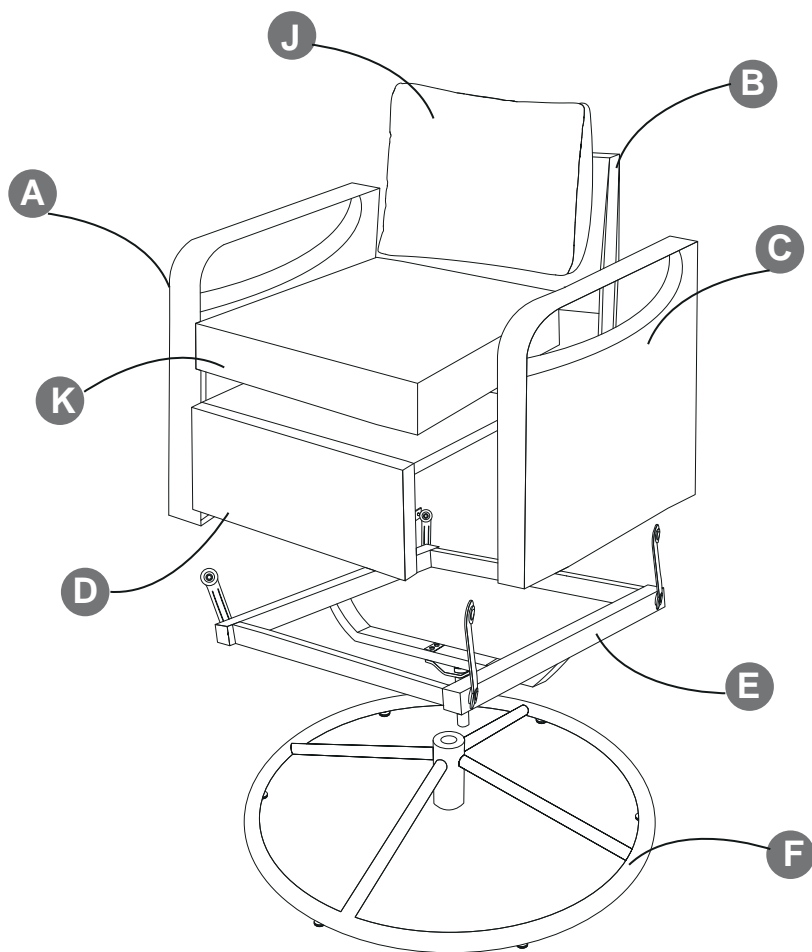
# PART LIST

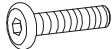
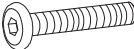

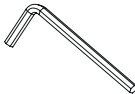
<p><b>Aa</b></p> 	<p><b>Ab</b></p> 	<p><b>Ac</b></p> 	<p><b>O</b></p> 	<p><b>P</b></p> 	<p><b>1</b></p> 
<p>M6*15</p> <p>2 PCS</p>	<p>M6*30</p> <p>4 PCS</p>	<p>M6*35</p> <p>8 PCS</p>	<p>M6</p> <p>10 PCS</p>	<p>4 PCS</p>	<p>1 PC</p>

# STEP

1

Tips: Please prioritize the installation of the screws inside the back panel for easy installation.

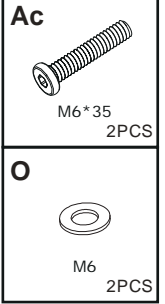
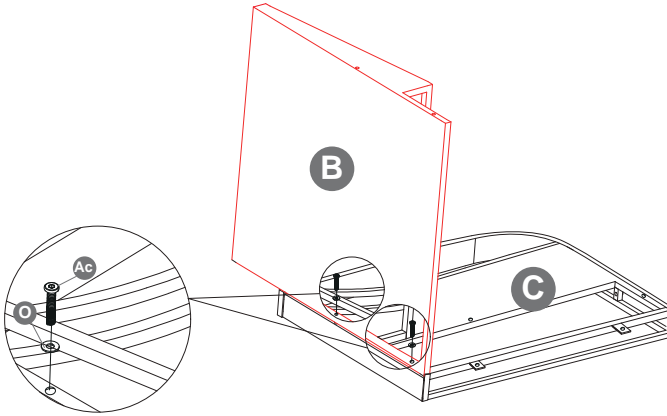

Do not tighten the screws immediately. Before tightening the screws, you must ensure that all screws are securely fastened at 60%.

2

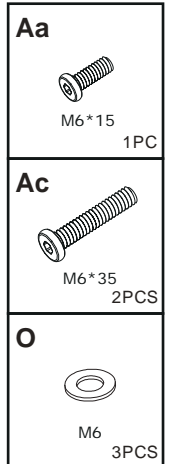
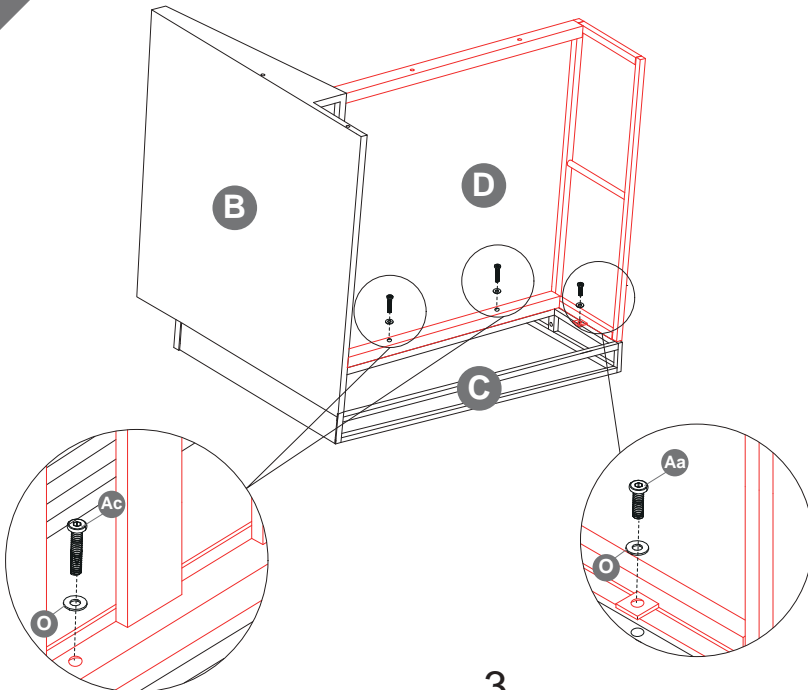

3

# STEP

3

Do not tighten the screws immediately, tighten the screws by 60% and proceed to the next step of the installation.

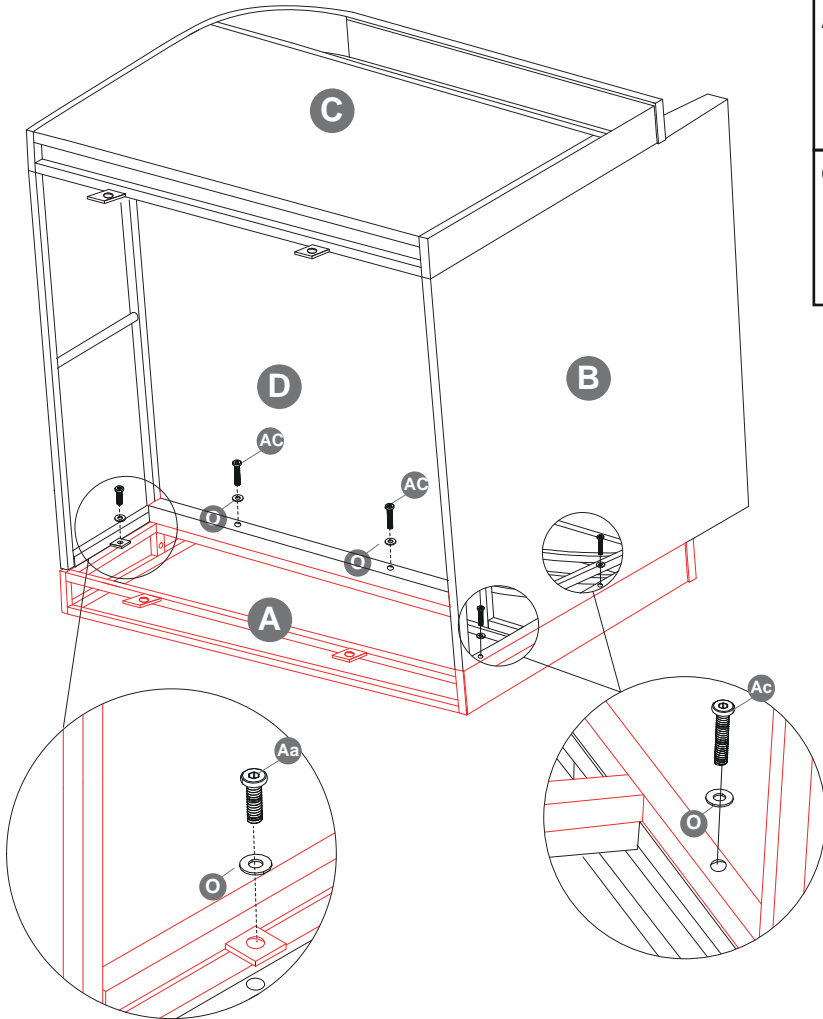
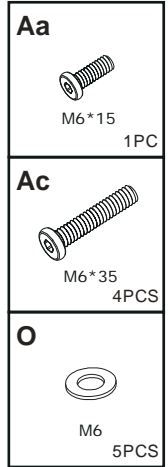

Tips: Please prioritize the installation of the screws inside the back panel for easy installation.

# STEP

4

Part E needs to be inside the chair

Ab



M6 \* 30  
4PCS

P



4PCS

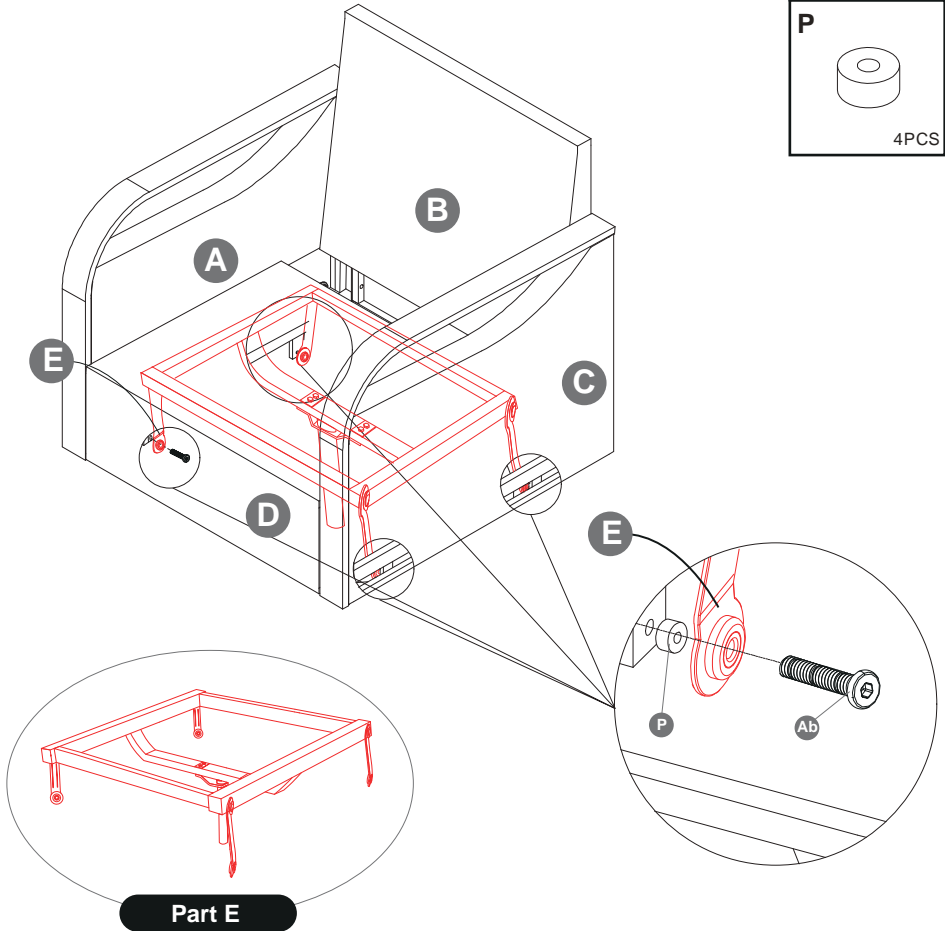

# STEP

5

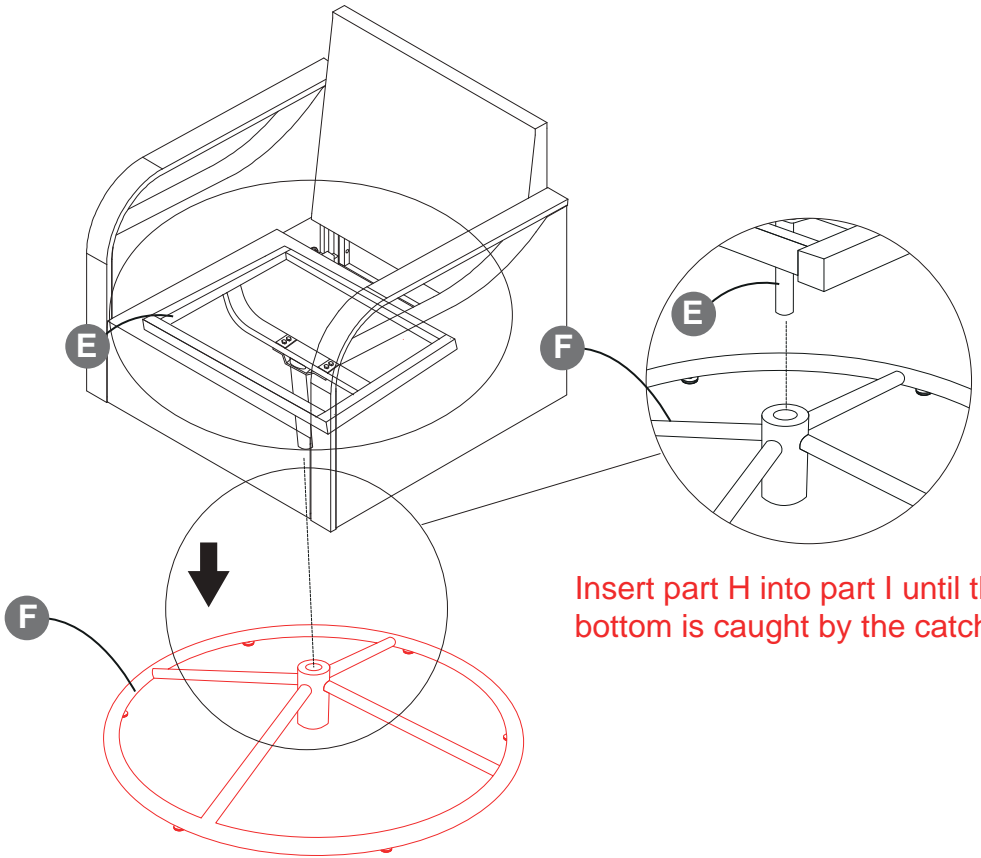

# STEP

6

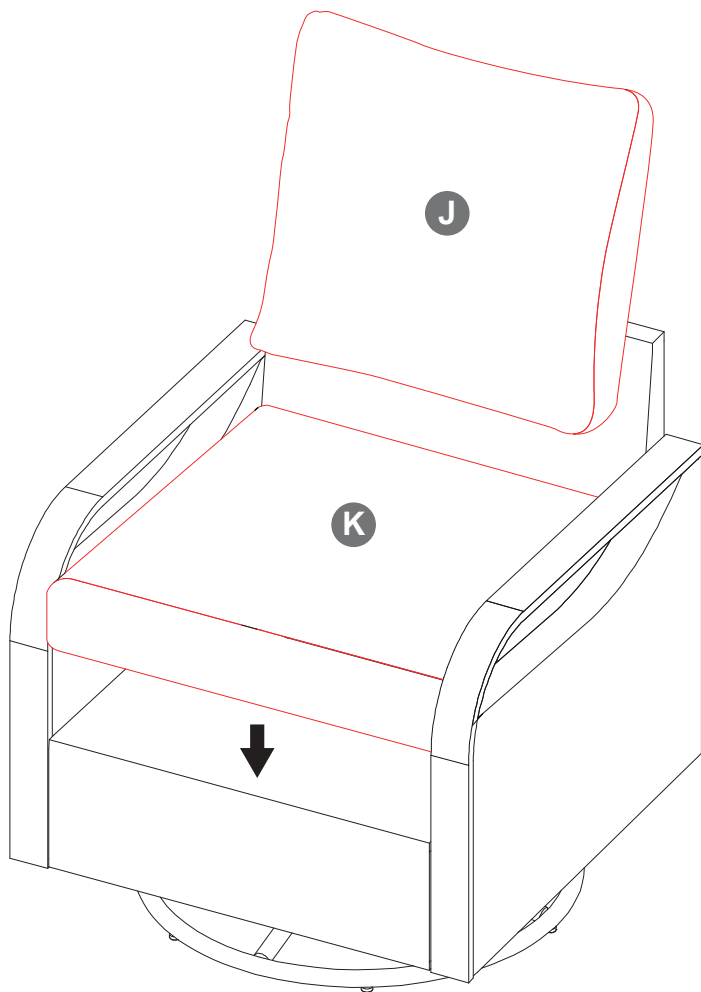

7

# STEP

7

Installation completed

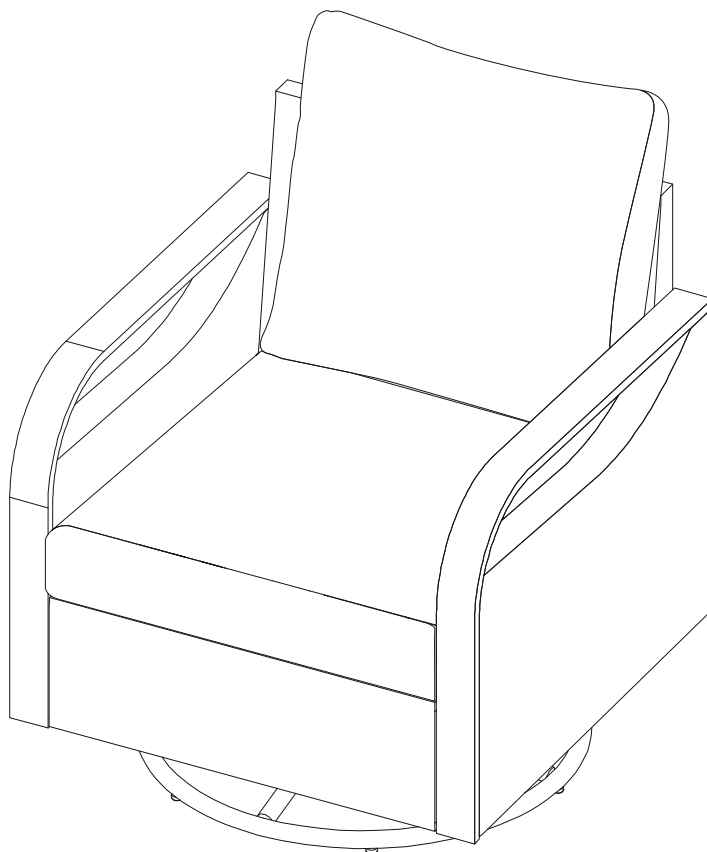

# AFTER-SALE SERVICE

If you have any suggestions for our products or find that the products have quality problems, please contact us first, our after-sales team will reply you within 24 hours, and we will do our best to give you solutions until you are satisfied.

## Guaranteed Customer Service

Your shopping experience is very important to us!

Feel unsatisfied? **Contact us!**

Have any questions? such as **MISSING PARTS** or **DAMAGED PRODUCTS? Contact us!**

Wanna Share how wonderful our smart promakes your home?

Share your pictures with us.

Any suggestions? **Contact us!**

We gotcha back!

**INSTRUCTION**

---

# **THREE-SEAT SOFA**

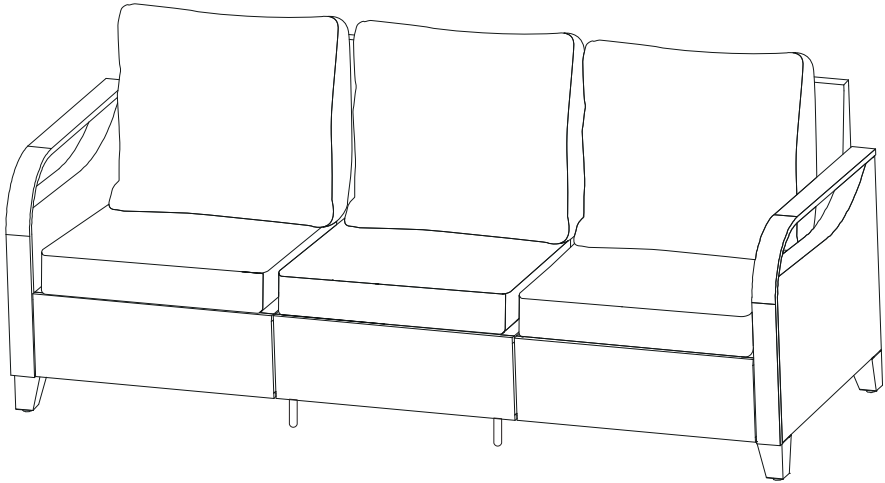

# NOTICE

---



**Please keep these instructions for future reference.**

**Dear Customer**

- Thank you for your purchase. When you receive the product, please make sure that all the parts are intact. Then follow the entire installation instructions to install!
- Please install under viewing the instruction, if you have some problem below, contact our customer service first.
  - A . The outer box is damaged
  - B . The product is damaged / bent / cracked while you open the box
  - C . The parts / accessories / assembly tools are missing
  - D . The instructions are not clear and can not be referred
  - E . The product has functional problems
  - F . Other aspects that you are not satisfied with

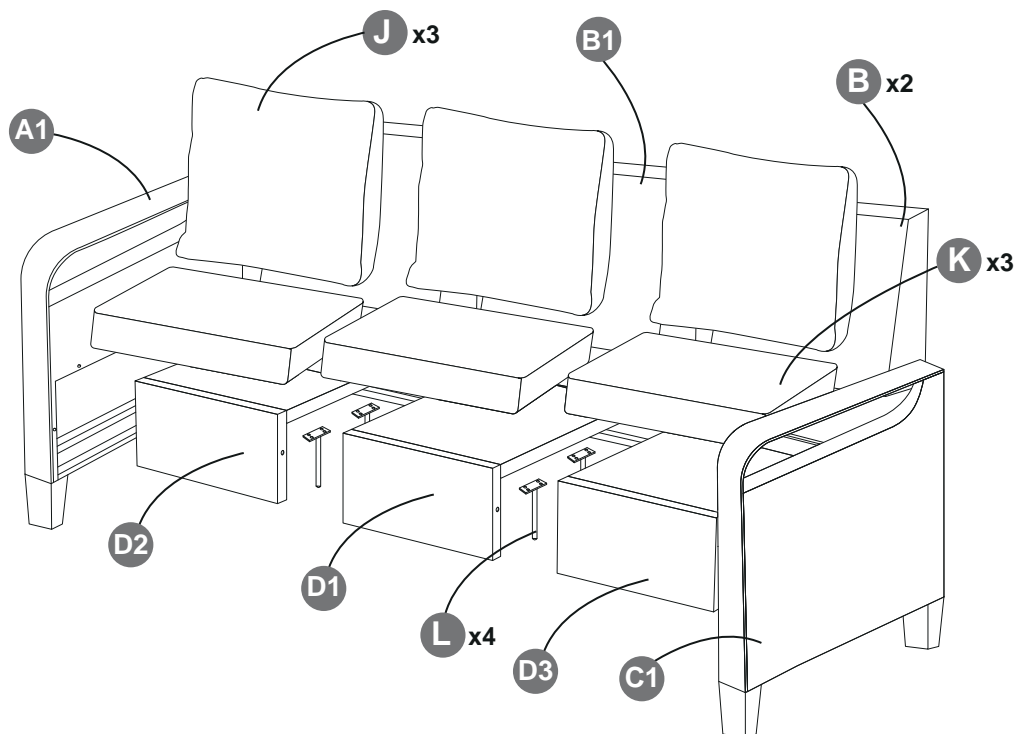
# PART LIST

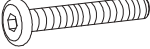

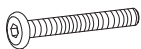
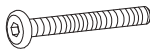
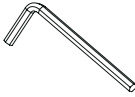
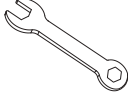
<p>(Aa)</p>  <p>M6*15</p> <p>10 PCS</p>	<p>(Ac)</p>  <p>M6*35</p> <p>10 PCS</p>	<p>(O)</p>  <p>M6</p> <p>40 PCS</p>	<p>(R)</p>  <p>M6</p> <p>10 PCS</p>	<p>(Af)</p>  <p>M6*55</p> <p>6 PCS</p>	<p>(Ag)</p>  <p>M6*60</p> <p>4 PCS</p>
<p>①</p>  <p>1 PC</p>	<p>②</p>  <p>Tool</p> <p>1 PC</p>				

# STEP

1

Tips: Please prioritize the installation of the screws inside the back panel for easy installation.

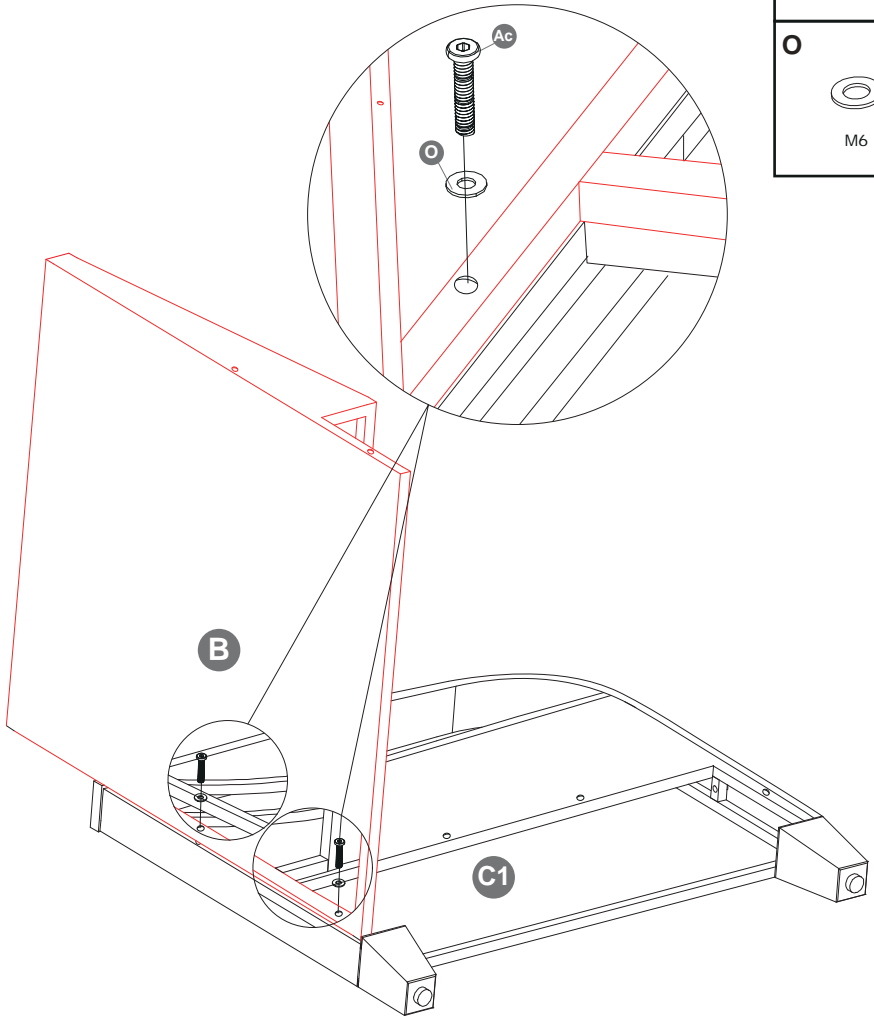
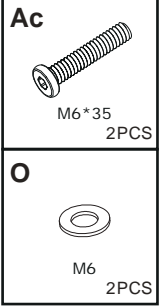



Do not tighten the screws immediately, tighten the screws by 60% and proceed to the next step of the installation.

# STEP

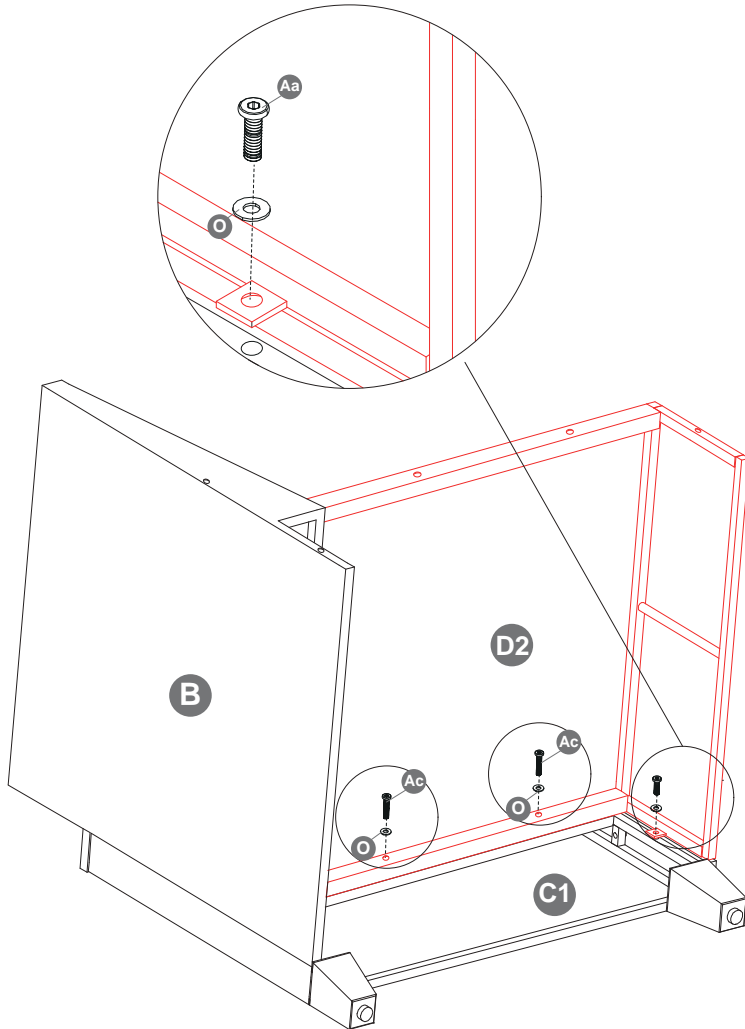
2



<b>Aa</b>  M6*15 1PC
<b>Ac</b>  M6*35 2PCS
<b>O</b>  M6 3PCS

Do not tighten the screws immediately, tighten the screws by 60% and proceed to the next step of the installation.

# STEP

3

Tips: Please prioritize the installation of the screws inside the back panel for easy installation.

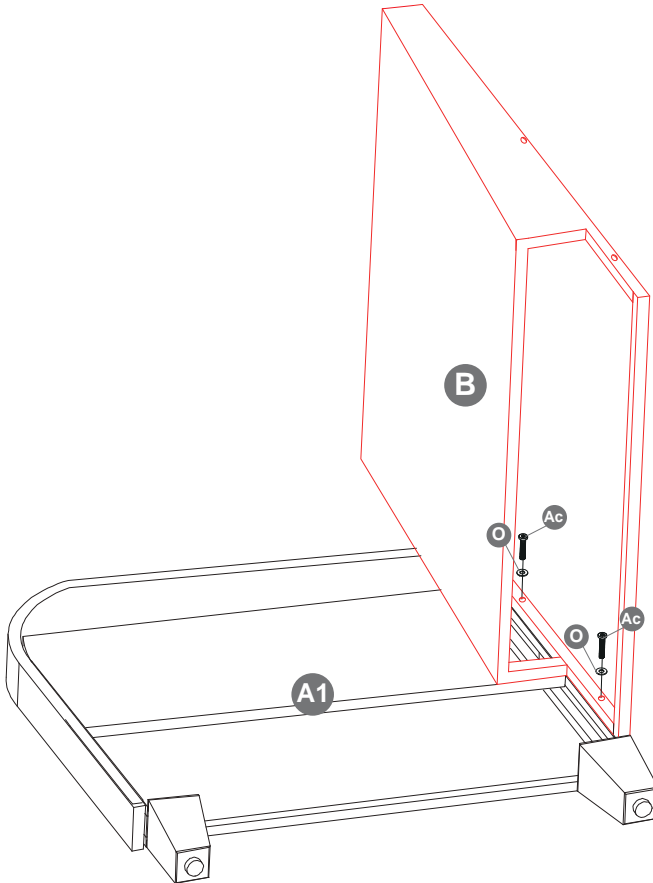
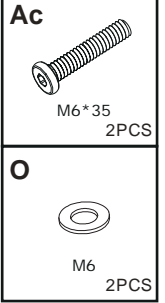



Do not tighten the screws immediately, tighten the screws by 60% and proceed to the next step of the installation.

# STEP

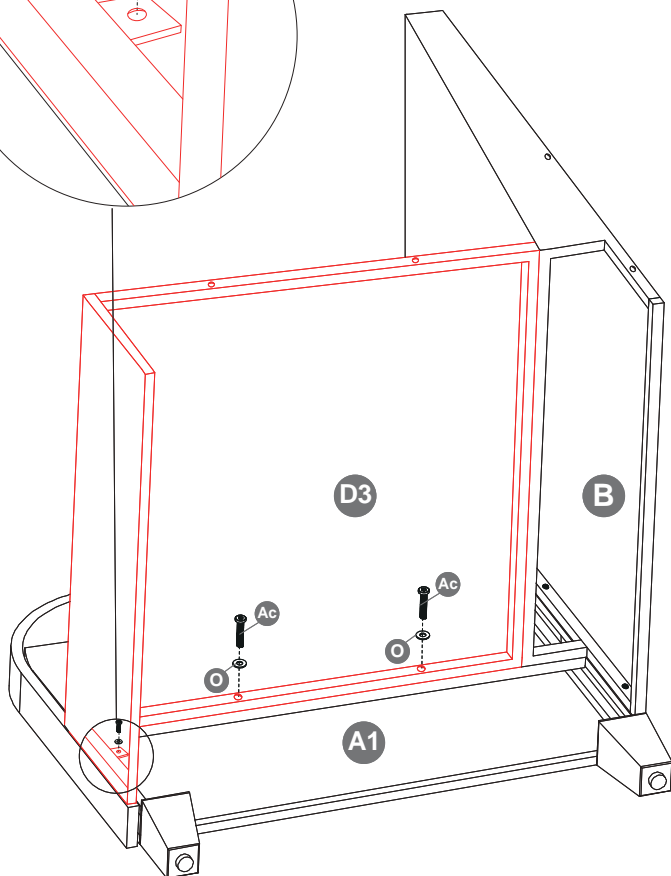
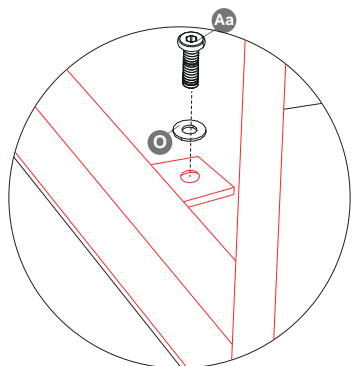
4



<b>Aa</b>  M6*15 1PC
<b>Ac</b>  M6*35 2PCS
<b>O</b>  M6 3PCS

Do not tighten the screws immediately, tighten the screws by 60% and proceed to the next step of the installation.

# STEP

5

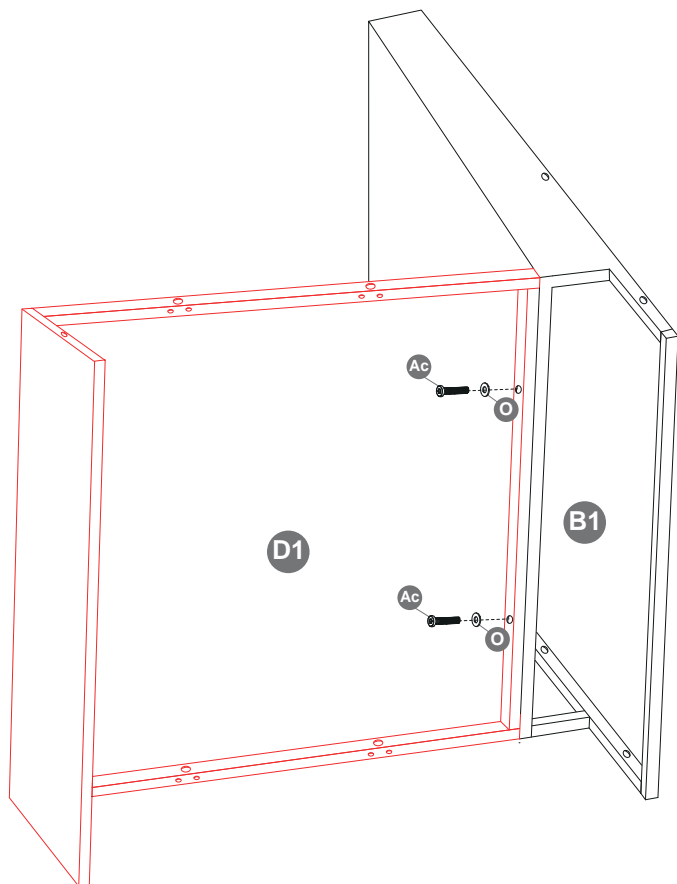
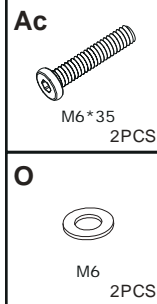

Do not tighten the screws immediately, tighten the screws by 60% and proceed to the next step of the installation.

# STEP

6

Tips: Please prioritize the installation of the screws inside the back panel for easy installation.

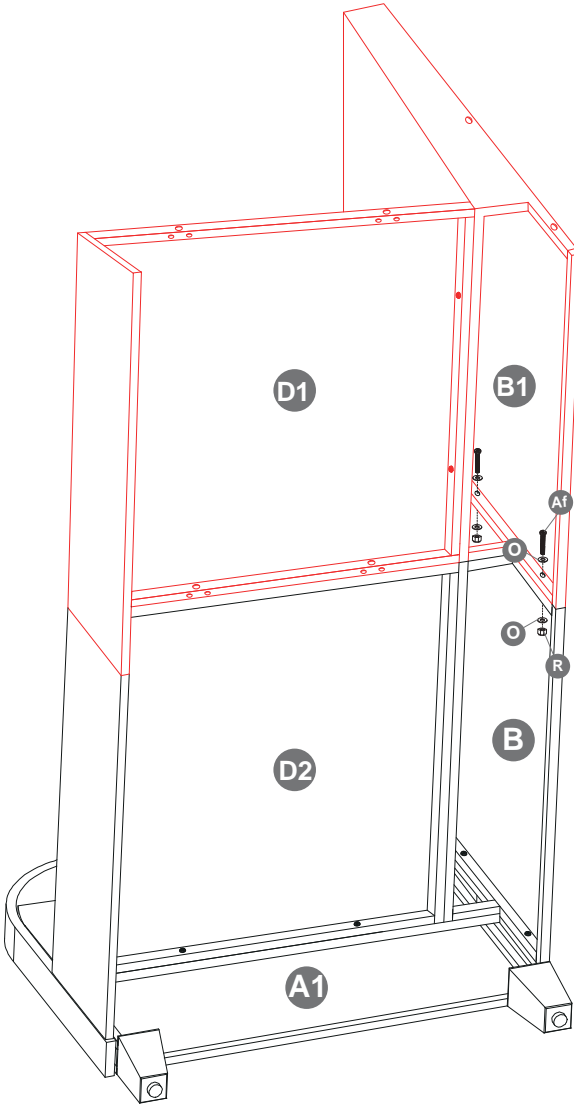

Af



O



R



Do not tighten the screws immediately, tighten the screws by 60% and proceed to the next step of the installation.

# STEP

7

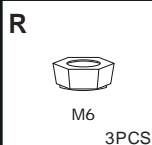
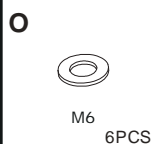
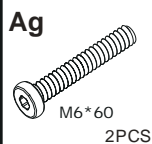
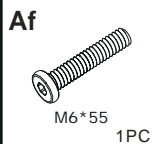
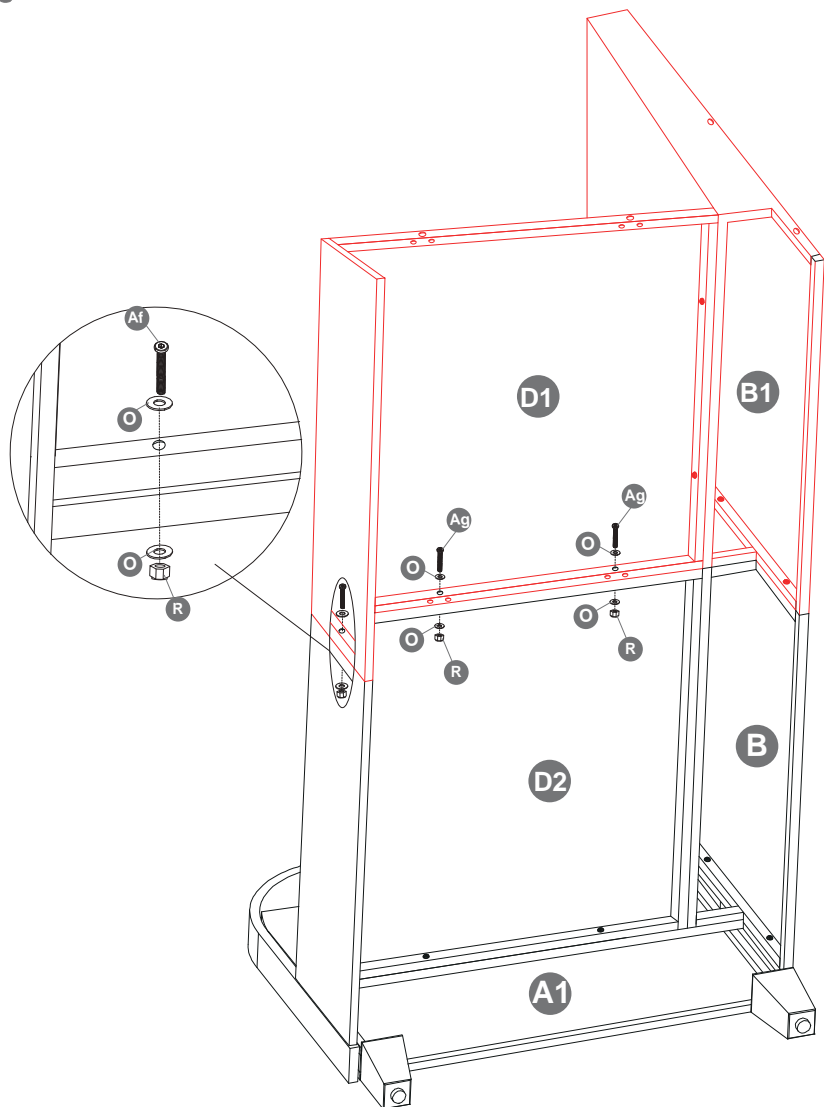

Do not tighten the screws immediately, tighten the screws by 60% and proceed to the next step of the installation.

# STEP

8

Tips: Please prioritize the installation of the screws inside the back panel for easy installation.

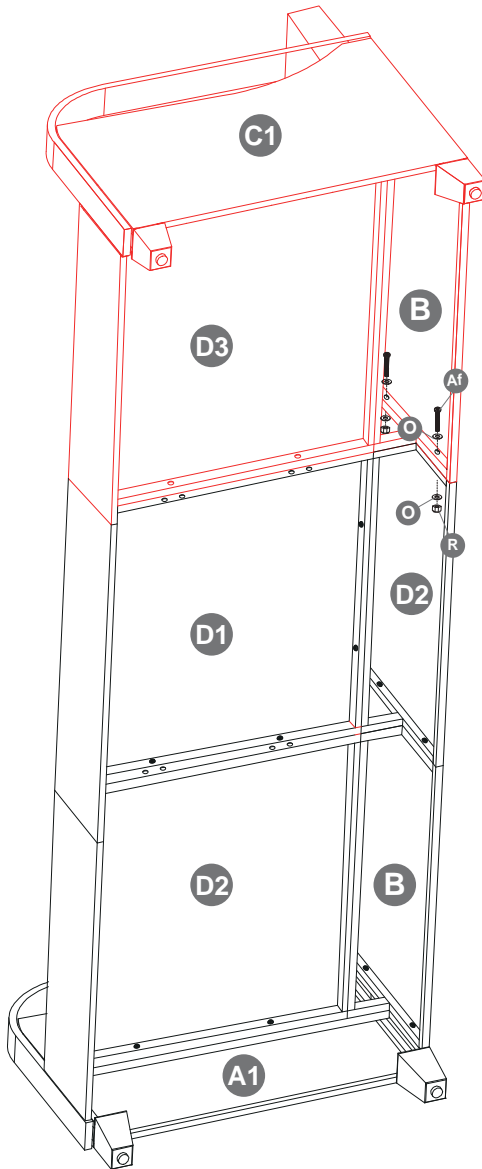

Af



M6\*55  
2PCS

O



M6  
4PCS

R







M6  
2PCS

Do not tighten the screws immediately, first tighten 60%, then tighten all the screws to the point of death.

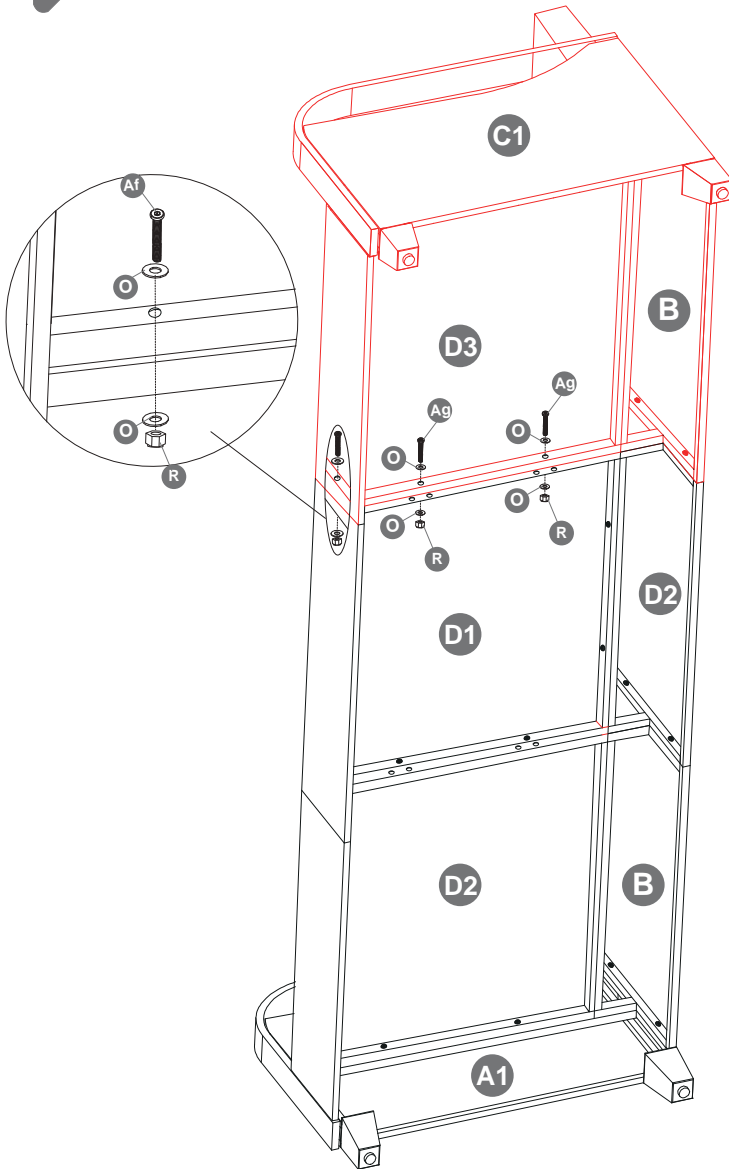
# STEP

9



<b>Af</b>  M6*55 1PC
<b>Ag</b>  M6*60 2PCS
<b>O</b>  M6 6PCS
<b>R</b>  M6 3PCS

Do not tighten the screws immediately, tighten the screws by 60% and proceed to the next step of the installation.

# STEP

10

Aa



M6 \* 15  
8PCS

O



M6  
8PCS

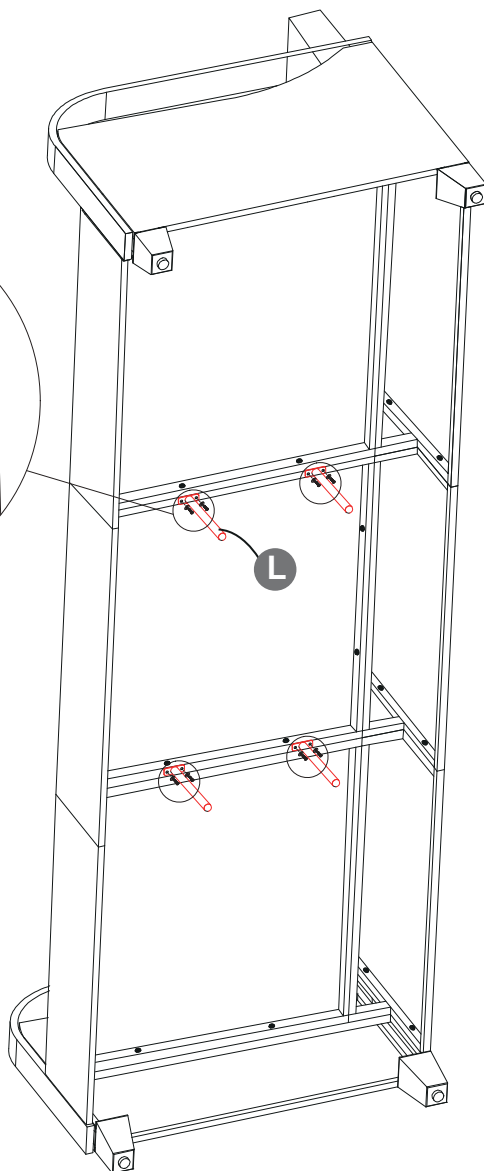
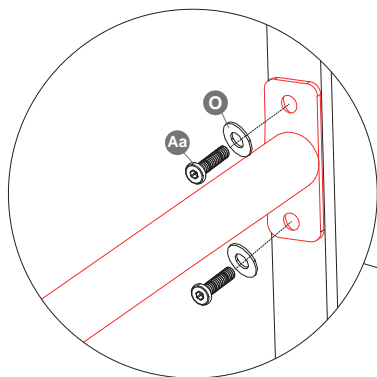

# STEP

11

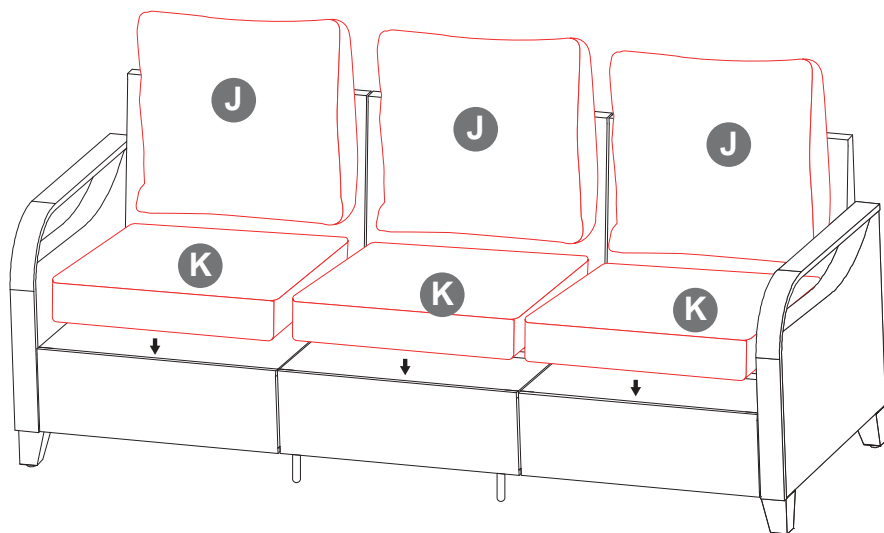

# STEP

---

12

Installation completed

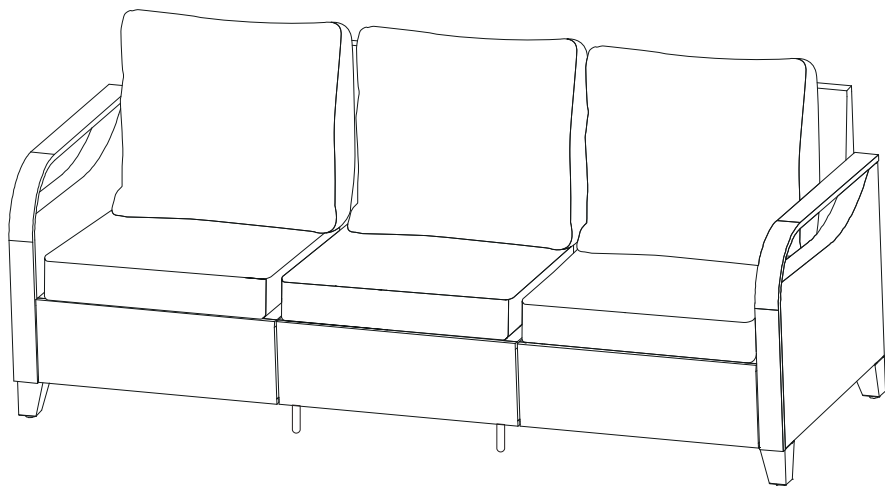

# AFTER-SALE SERVICE

If you have any suggestions for our products or find that the products have quality problems, please contact us first, our after-sales team will reply you within 24 hours, and we will do our best to give you solutions until you are satisfied.

## Guaranteed Customer Service

Your shopping experience is very important to us!

Feel unsatisfied? **Contact us!**

Have any questions? such as **MISSING PARTS** or **DAMAGED PRODUCTS? Contact us!**

Wanna Share how wonderful our smart promakes your home?

Share your pictures with us.

Any suggestions? **Contact us!**

We gotcha back!

**INSTRUCTION**

---

# **COFFEE TABLE**

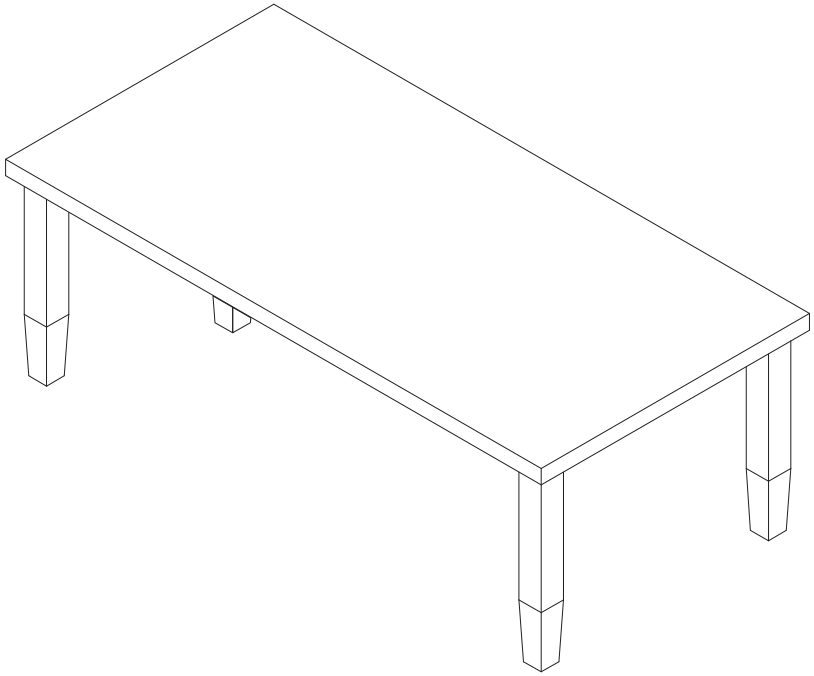

# NOTICE

---



**Please keep these instructions for future reference.**

**Dear Customer**

- Thank you for your purchase. When you receive the product, please make sure that all the parts are intact. Then follow the entire installation instructions to install!
- Please install under viewing the instruction, if you have some problem below, contact our customer service first.
  - A . The outer box is damaged
  - B . The product is damaged / bent / cracked while you open the box
  - C . The parts / accessories / assembly tools are missing
  - D . The instructions are not clear and can not be referred
  - E . The product has functional problems
  - F . Other aspects that you are not satisfied with

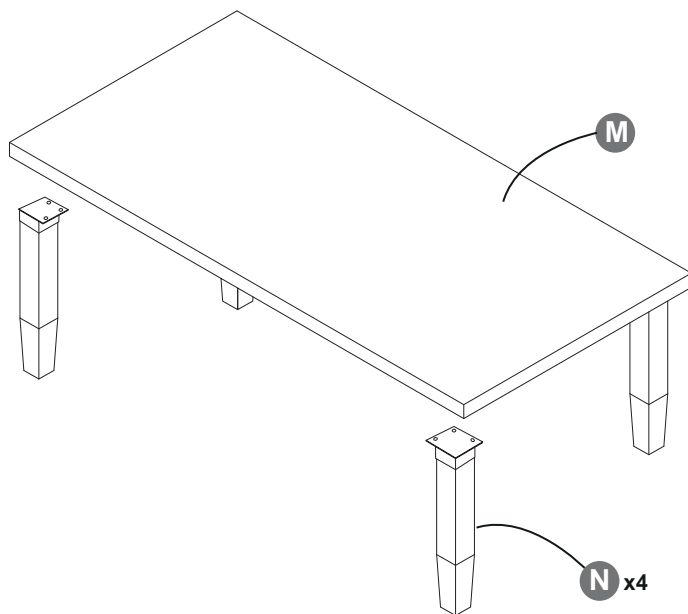
# PART LIST

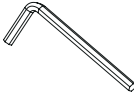

<p>(Aa)</p>  <p>M6*15</p>	<p>(O)</p>  <p>M6</p>	<p>(1)</p>  <p>1 PC</p>
<p>12 PCS</p>	<p>12 PCS</p>	<p>1 PC</p>

# STEP

1

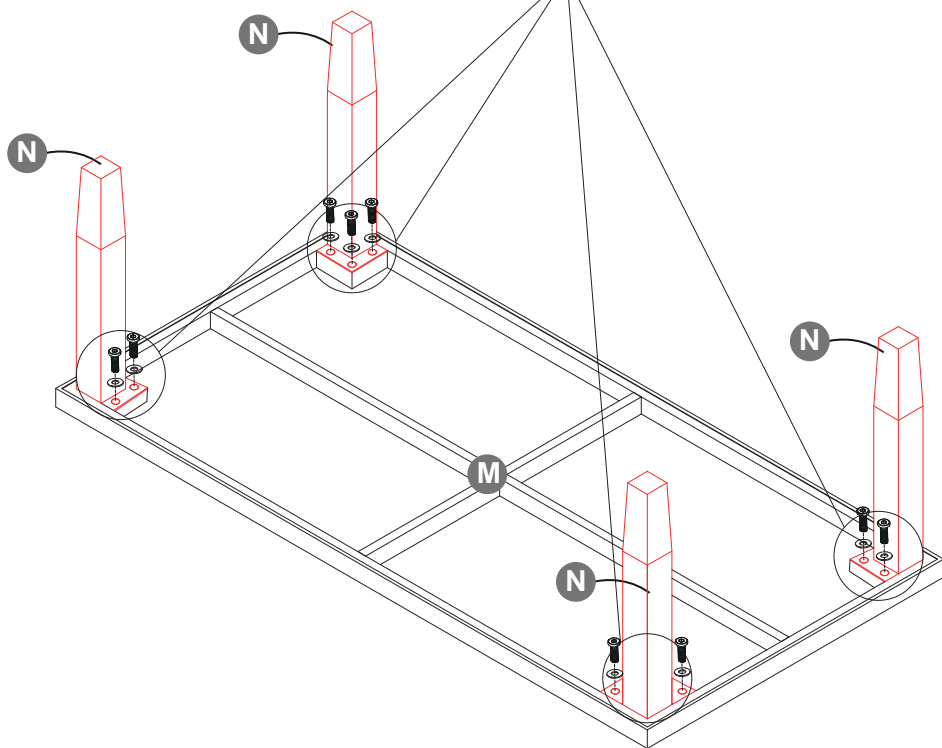
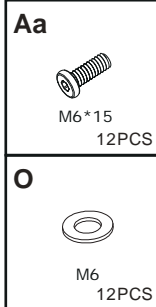
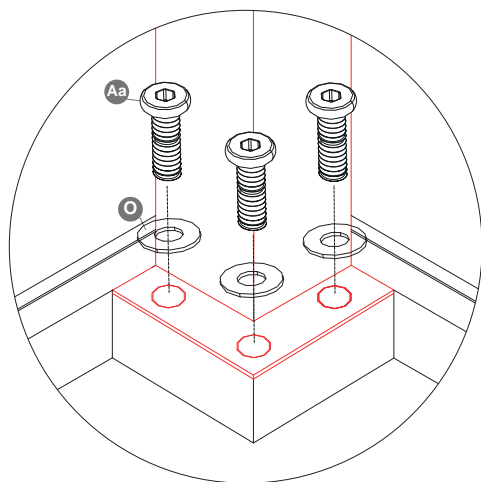

# STEP

---

2

Installation completed

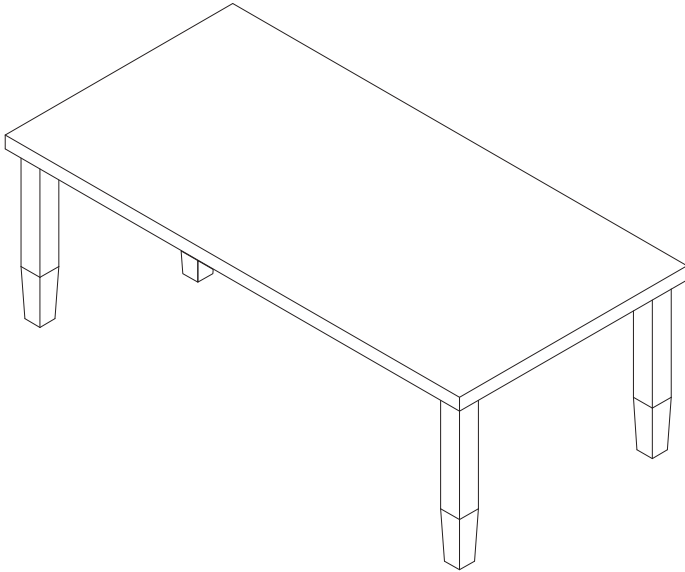

# AFTER-SALE SERVICE

If you have any suggestions for our products or find that the products have quality problems, please contact us first, our after-sales team will reply you within 24 hours, and we will do our best to give you solutions until you are satisfied.

## Guaranteed Customer Service

Your shopping experience is very important to us!

Feel unsatisfied? **Contact us!**

Have any questions? such as **MISSING PARTS** or **DAMAGED PRODUCTS? Contact us!**

Wanna Share how wonderful our smart promakes your home?

Share your pictures with us.

Any suggestions? **Contact us!**

We gotcha back!