

ASSEMBLY INSTRUCTIONS

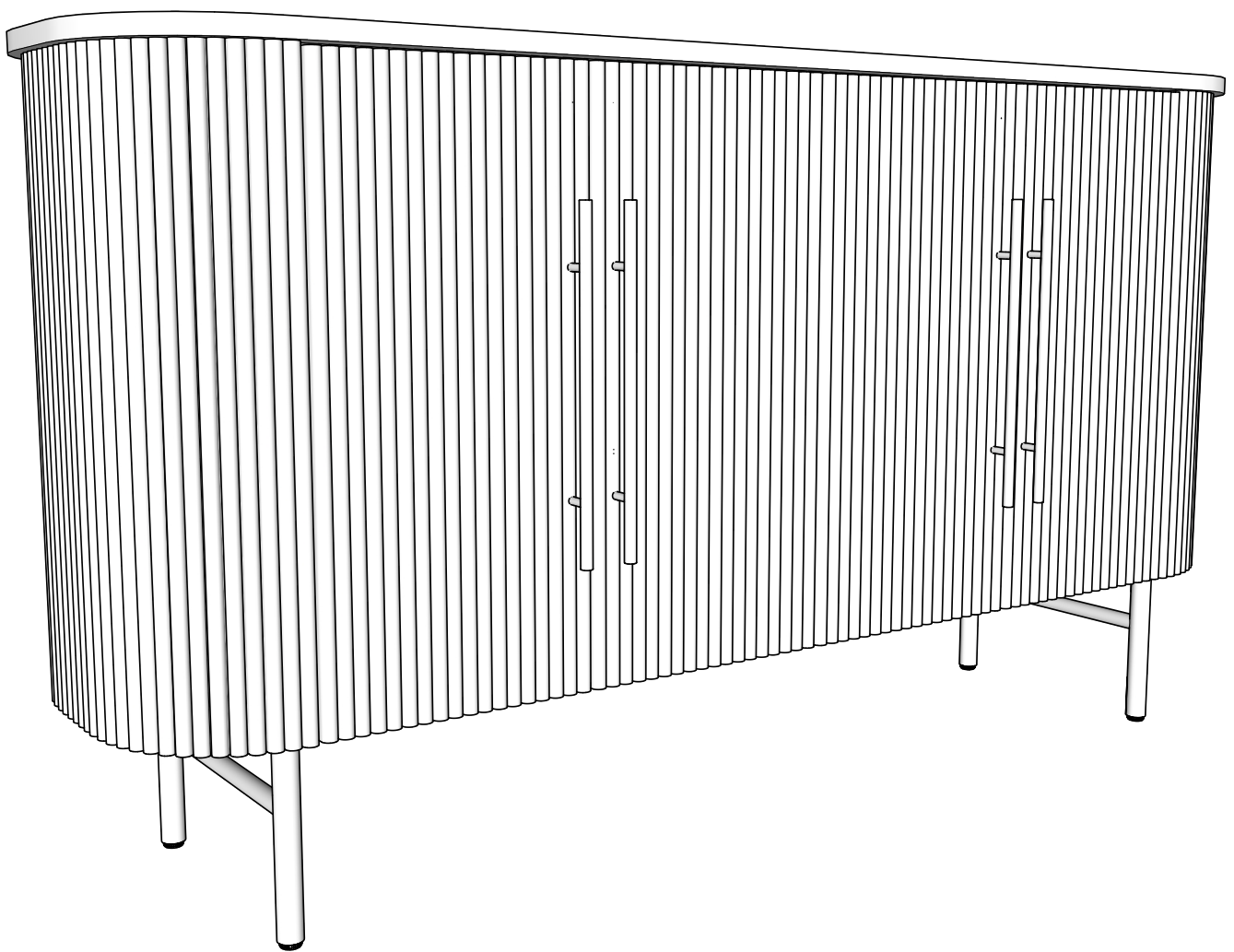



IMPORTANT INFORMATION

Seller and Manufacturer disclaim all and any liability for property damage, personal injury, or loss, direct, indirect, or incidental, resulting from the incorrect assembly, inadequate maintenance, improper use, or neglect of this product.



NOTICE

- Keep these assembly instructions for future reference.
- Do not use this product if there are missing, damaged, or broken parts until repairs are made and/or factory replacement parts are installed.
- Check all packing material carefully for small hardware that may have become loose inside the carton during shipment.
- Identify and count all hardware and parts to compare with parts and hardware list.
- Follow assembly instructions closely. Improper assembly can result in personal or property damage.
- Secure all bolts before use.
- Every 90 days check all bolts are secured.
- Some parts may have a sharp corner or edge and maybe heavy.
- Do not use or store this product near open flames or around flammable chemicals.
- When placing contents on non-carpeted flooring, it's recommended to use floor protection such as an area rug or furniture pads. These are not included with the purchase.

REPLACEMENT PART OR HARDWARE REQUEST:

Request a replacement by logging into the marketplace account in which the purchase was made and sending a message to the seller. To assist in expediting the request attach applicable images relevant to the request and/or part number and quantity.

ADDITIONAL TOOL REQUIRED:

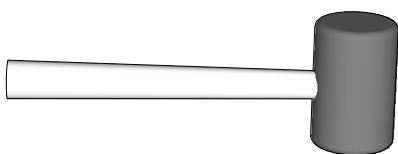

**Mallet
(Not Provided)**

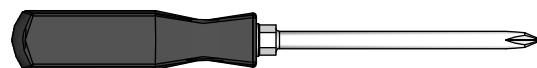

**#2 Philips Screwdriver
(Not Provided)**

LOAD CAPACITY

MAX: 185 lbs

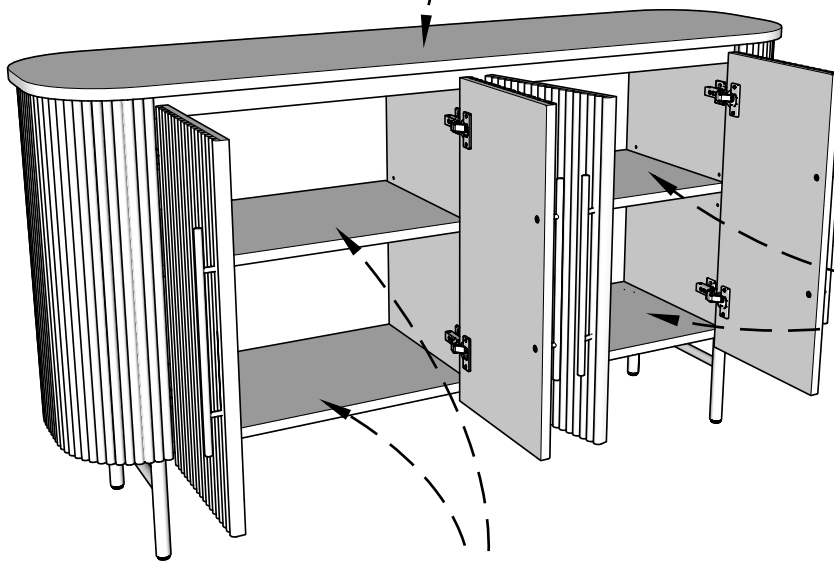
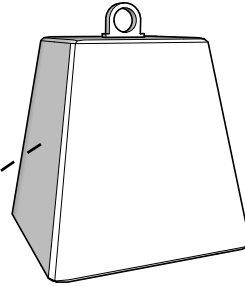

MAX: 22 lbs

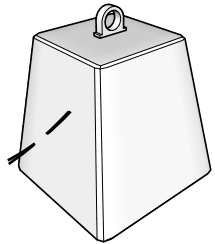

MAX: 22 lbs

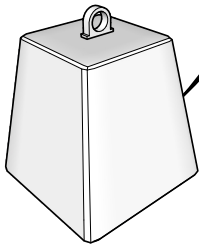



PARTS

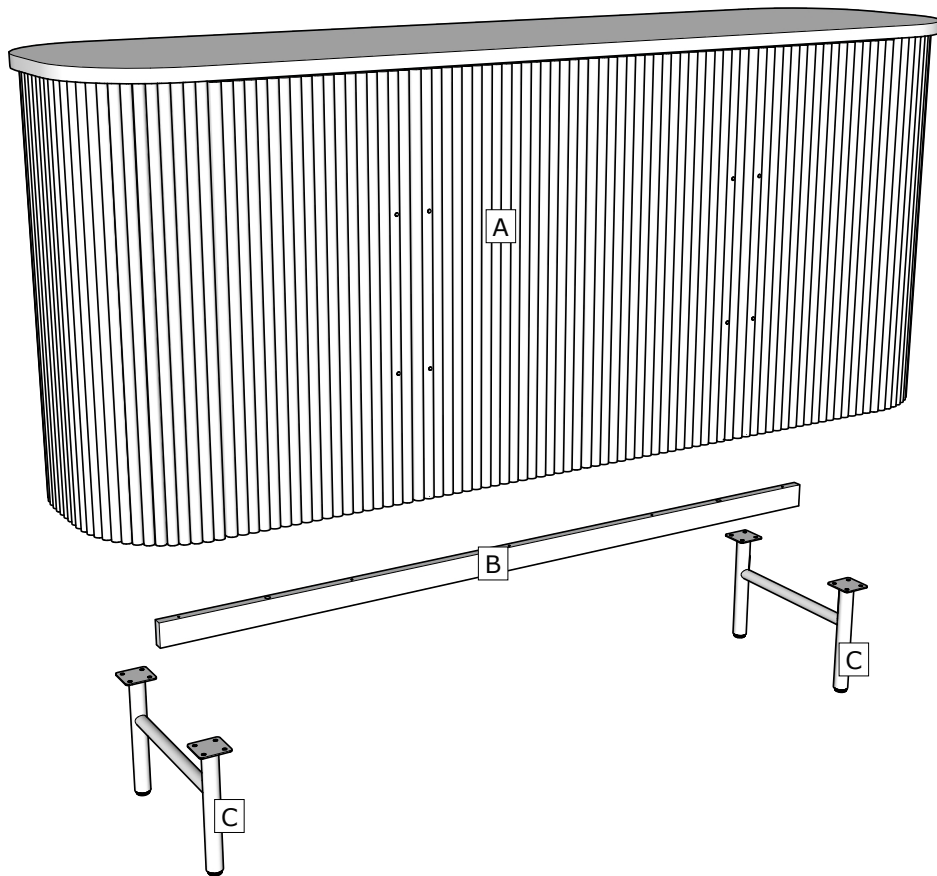

- A..... Buffet Cabinet x 1
- B..... Bottom Panel Support..... x 1
- C..... Feet x 2

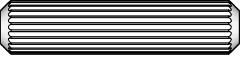
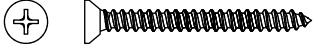

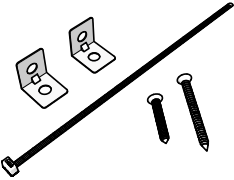
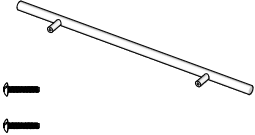
HARDWARE

<p>D Dowel x 2  M8 x 30mm</p>	<p>E Screw x 5  M4 x 30mm</p>	<p>F Screw x 16  M4 x 20mm</p>
<p>G Anti-Tip Kit x 2 </p>	<p>H Handle x 4 </p>	

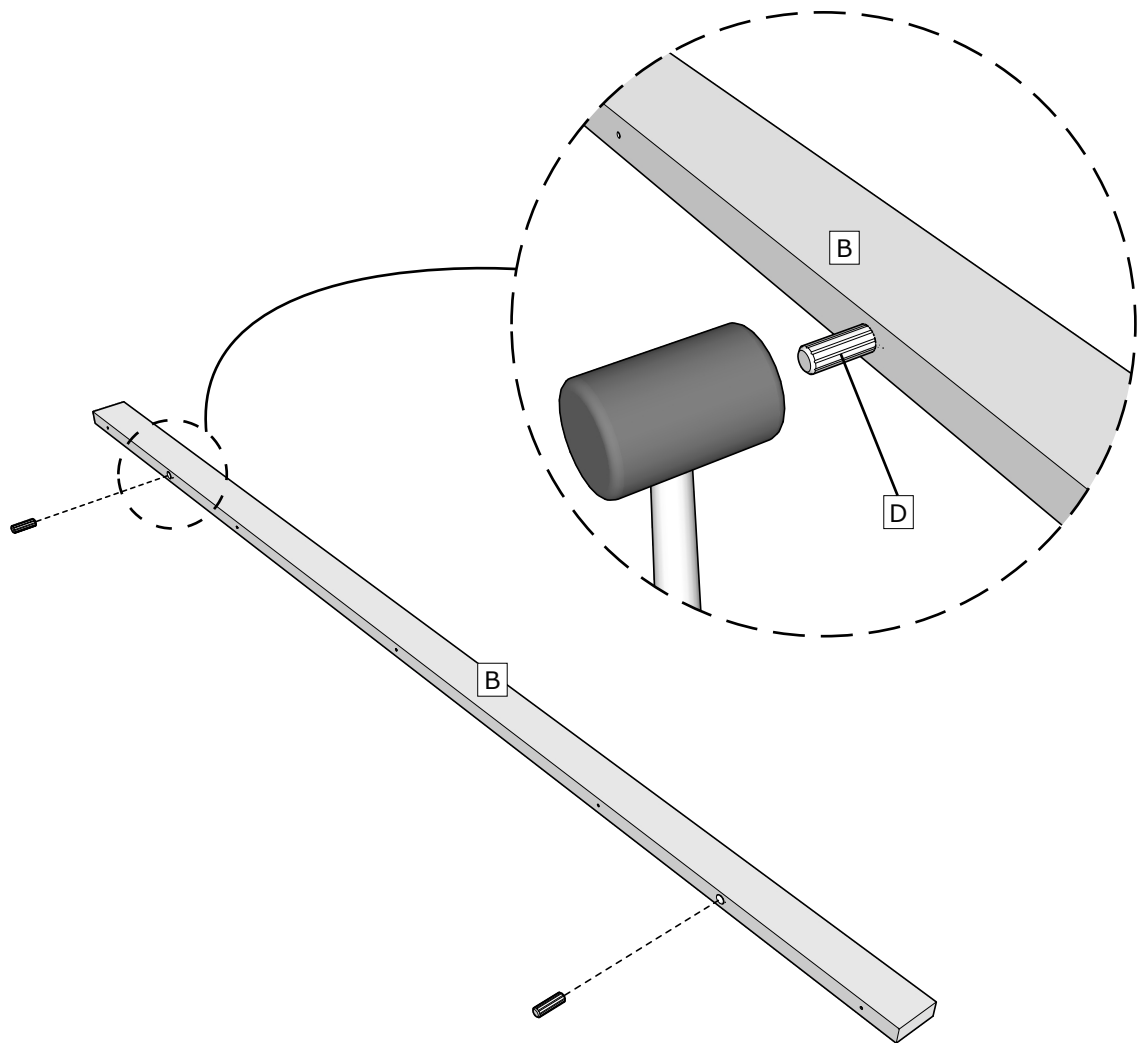

ASSEMBLY STEP 1

B Bottom Panel Support x1 	Q Dowel x2 M8 X 30mm 	Mallet  Not provided
---	---	---



Insert **D** to **B** using a Mallet as shown.

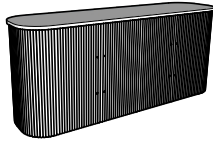

ASSEMBLY STEP 2

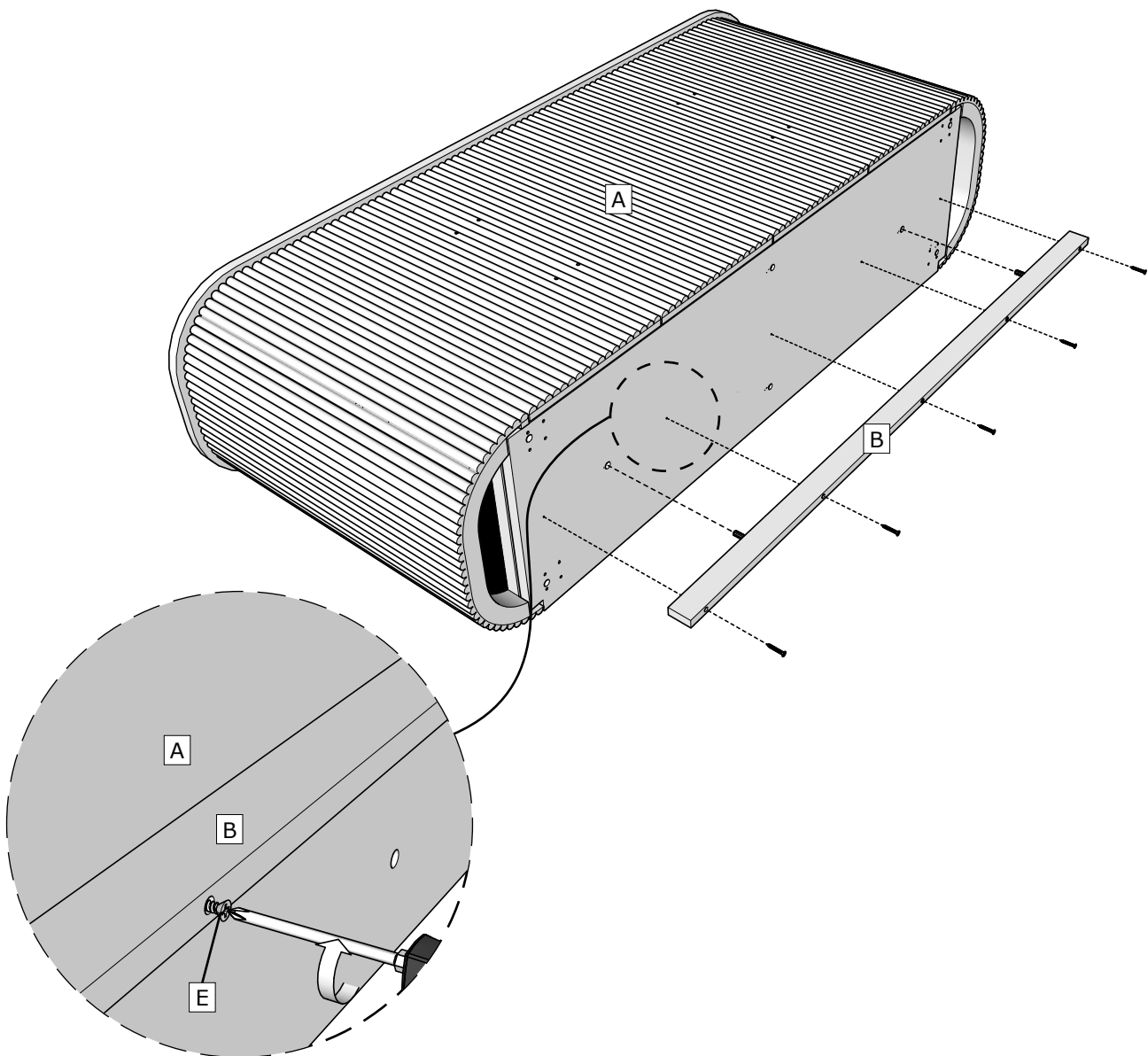
A Buffet Cabinet x1 	E Screw x5  M4 x 30mm	Philips Screwdriver  Not provided
--	--	---

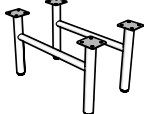
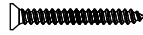

Attach **B** to **A** with **E** using a Philips Screwdriver as shown.

ASSEMBLY STEP 3

C Buffet Cabinet x2 	F Screw x16 ⊕  M4 x 20mm	Philips Screwdriver  Not provided
--	--	---

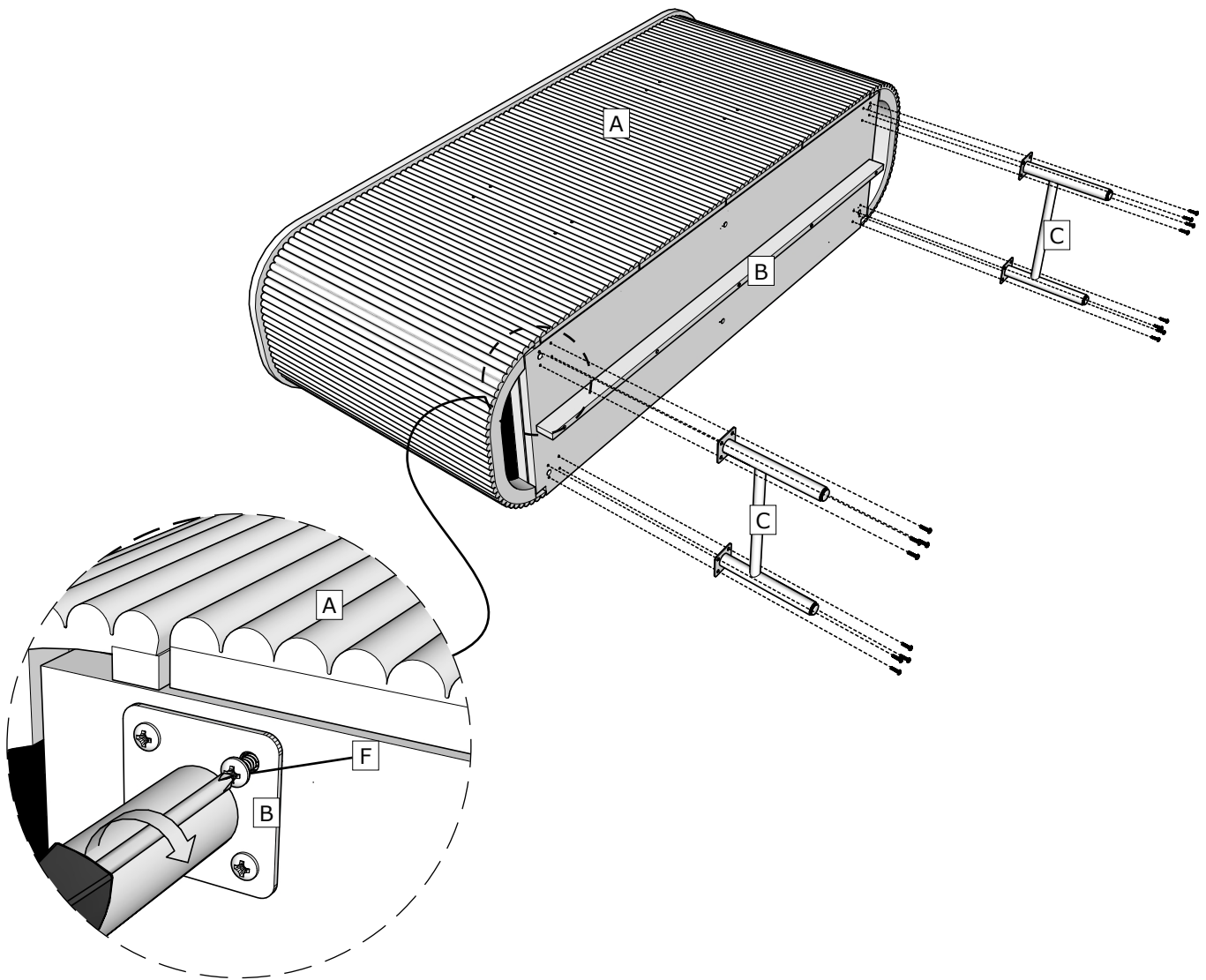

Attach **C** to **A** with **F** using a Philips Screwdriver as shown.

ASSEMBLY STEP 4

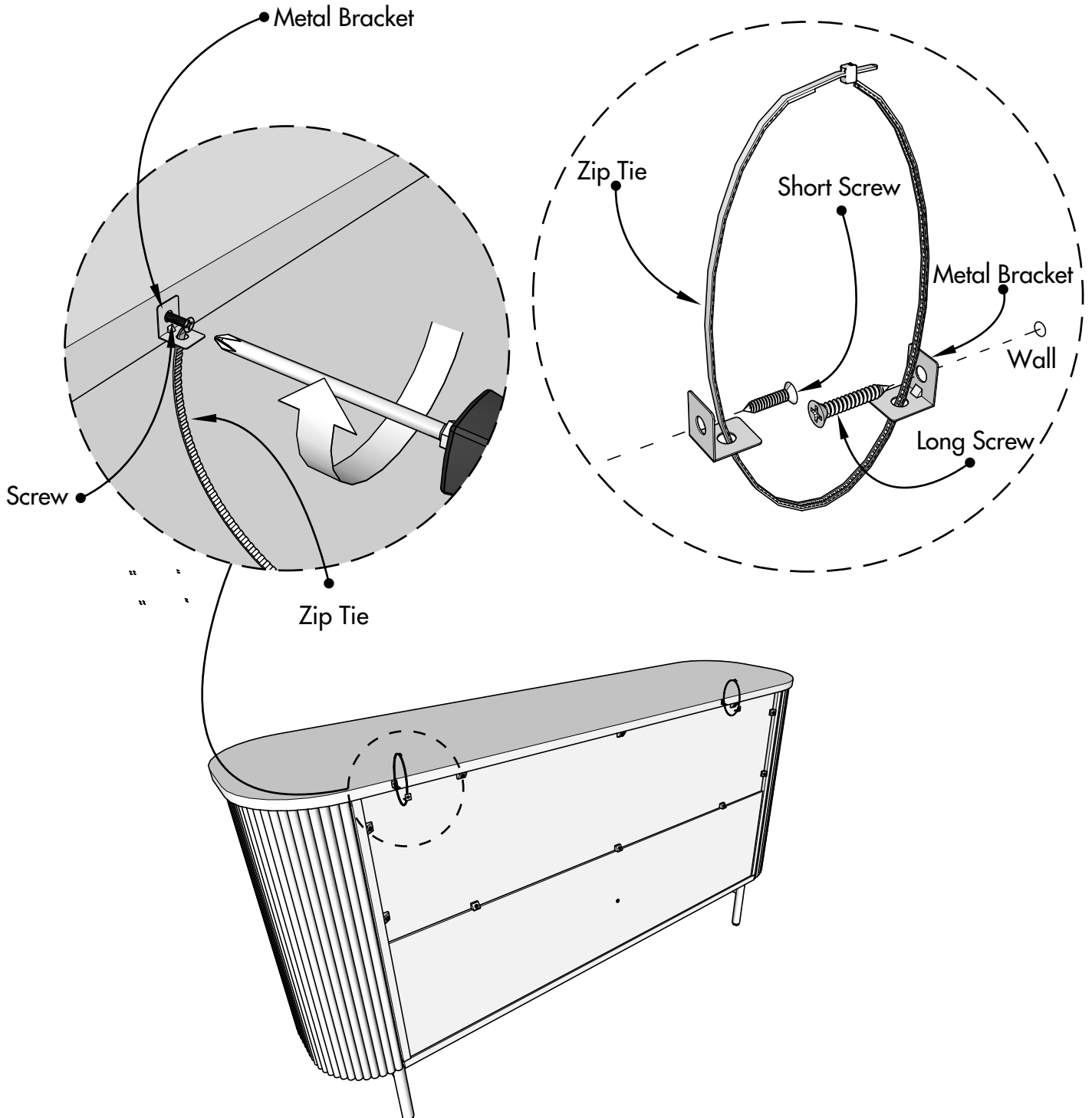
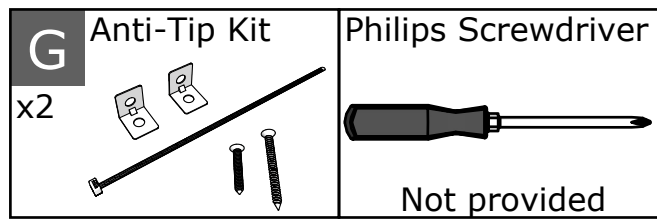

Attach one each side Metal Bracket at the back of the Dresser and the other one on the wall
Insert Zip Tie on the holes of Metal Bracket as shown.

ASSEMBLY STEP 5

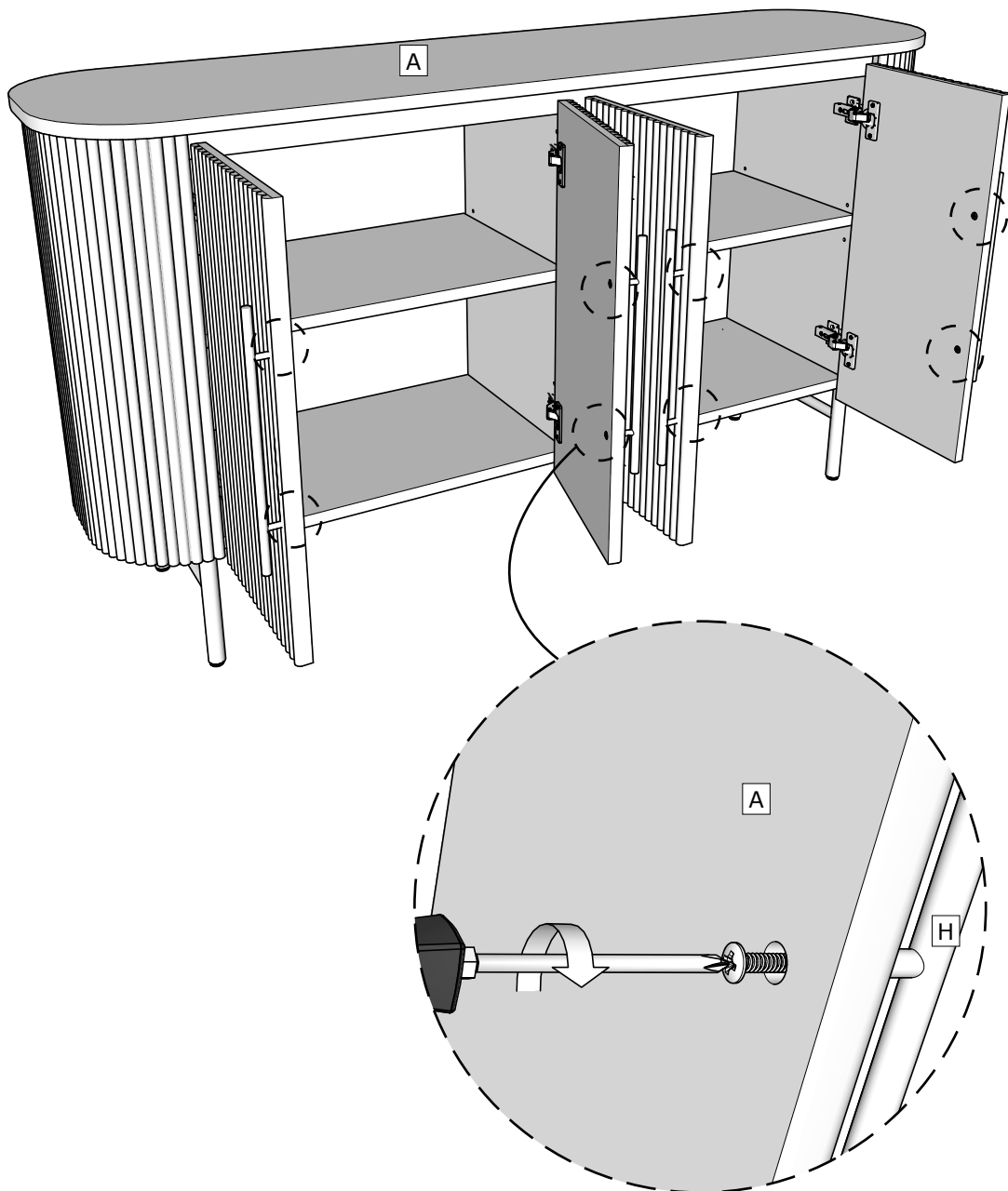
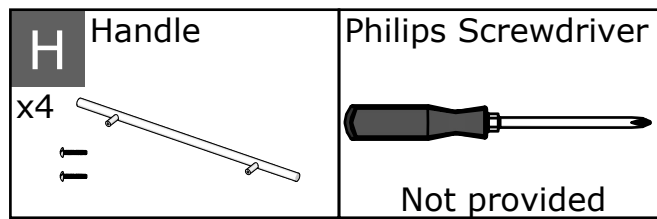

Attach **H** to Assembled Cabinet using a Philips Screwdriver as shown.

DOOR ADJUSTMENTS

Philips Screwdriver



Not provided

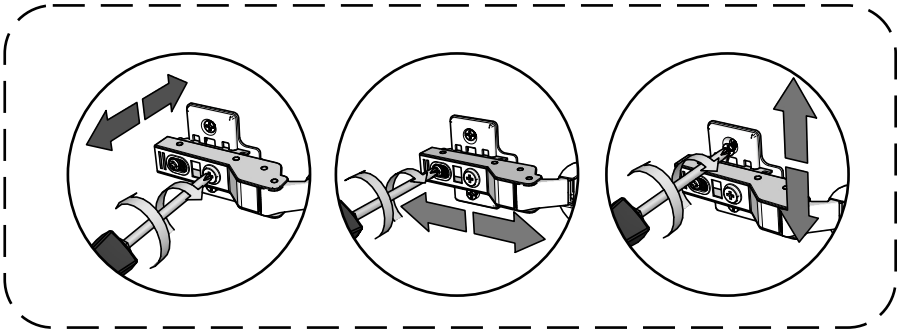
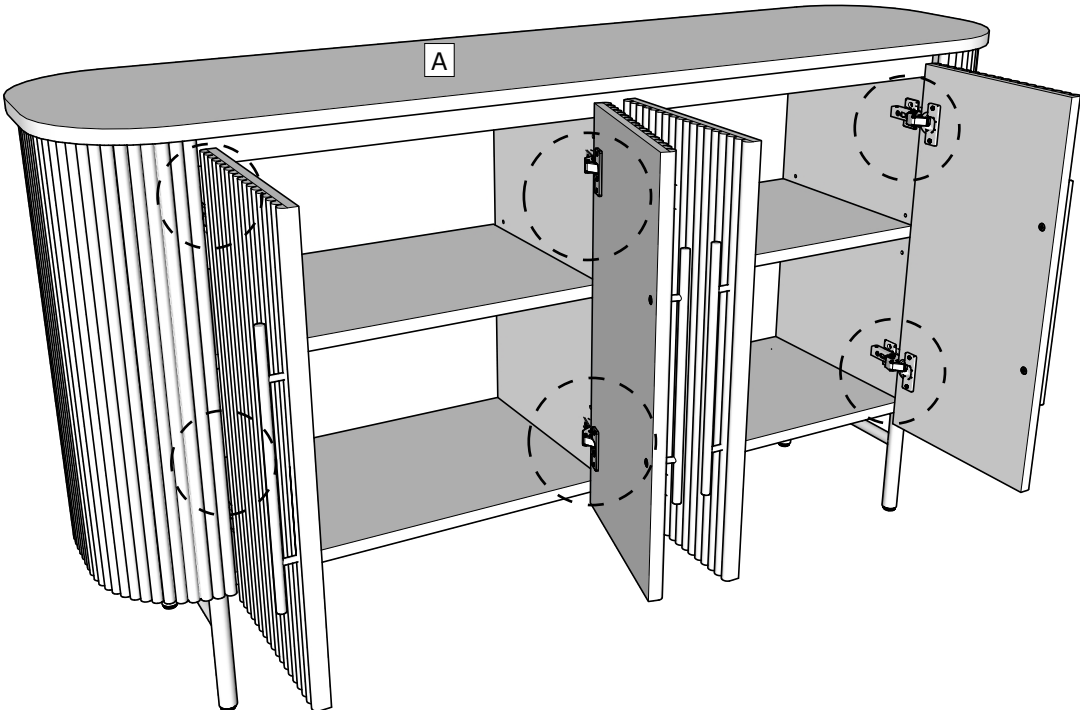

FAQS FREQUENTLY ASKED QUESTIONS

WE WILL REPLY TO ANY OF YOUR MESSAGES WITHIN 24-48 HOURS. THE AVERAGE RESPONSE TIME IS WITHIN 24 HOURS. IF YOU ENCOUNTER AN ISSUE THAT IS NOT MENTIONED BELOW, PLEASE CONTACT US

WHERE IS THE REST OF MY ORDER? THE PACKAGE I RECEIVED SAYS CARTON NO. 1 OF 3, CARTON NO. 3 OF 5, OR CARTON NO. 5 OF 6 ETC.

THE MARKETPLACE ONLY ALLOWS 1 TRACKING NUMBER TO BE UPLOADED IN THE SYSTEM. HOWEVER, THE PRODUCT IS SHIPPED IN MULTIPLE PACKAGES. YOU CAN CONFIRM THE NUMBER OF PACKAGES TO RECEIVE BY REFERRING TO THE CARTON NO. PRINTED ON THE PACKAGE THAT WAS DELIVERED TO YOU. FOR EXAMPLE, YOU RECEIVED 1 PACKAGE AND THE PACKAGE SHOWS CARTON NO. 1 OF 3, THEN CARTON NO. 2 OF 3 AND CARTON NO. 3 OF 3 IS IN TRANSIT TO YOU. THE REST OF THE PACKAGES CAN BE DELIVERED WITHIN THE SAME DAY AS THE FIRST PACKAGE OR WITHIN A FEW DAYS. ONCE THE ORDER IS SHIPPED CONFIRMED, OUR TEAM WILL SEND YOU A MESSAGE TO PROVIDE YOU WITH ALL THE TRACKING NUMBER THAT COMPLETES YOUR ORDER. IF YOU DID NOT RECEIVE THIS MESSAGE, PLEASE CHECK YOUR EMAIL'S SPAM FOLDER, OR LOG INTO THE MARKETPLACE ACCOUNT AND SEND US A MESSAGE.

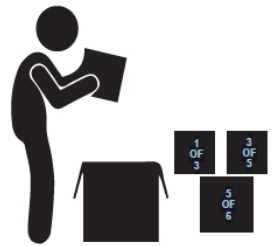

MY ORDER IS DAMAGED, WHAT DO I DO?

CONTACT US INCLUDE THE ORDER NUMBER AND ATTACH APPLICABLE IMAGES TO EXPEDITE THE CLAIM AND ENSURE OUR TEAM WILL PROVIDE THE APPROPRIATE RESOLUTION

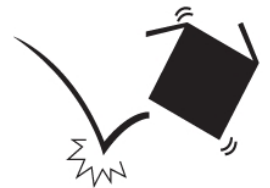

I TRACKED THE PACKAGE AND IT SHOWS MY PACKAGE WAS DELIVERED, BUT I NEVER RECEIVED THE PACKAGE. I DOUBLE CHECKED WITH MY FAMILY MEMBER AND NEIGHBOR; THEY DO NOT HAVE THE PACKAGE. WHAT DO I DO?

CONTACT US INCLUDE THE ORDER NUMBER AND LET US KNOW WHICH CARTON NUMBER OR TRACKING NUMBER YOU DID NOT RECEIVE, AND A TEAM MEMBER WILL REPLY TO YOUR MESSAGE ACCORDINGLY.



LOVE THE PRODUCT?

LOG INTO THE MARKETPLACE YOU MADE THE ORDER AND SHARE YOUR EXPERIENCE WITH THE PRODUCT AND WHAT YOU LIKE MOST ABOUT IT. ELEVATE THE PRODUCT REVIEW BY INCLUDING IMAGES OF THE PRODUCT TO SHARE WITH EVERYONE.

