

# *ASSEMBLY INSTRUCTIONS*



*COFFEE TABLE*

# ASSEMBLY INSTRUCTIONS

## ASSEMBLY TIPS:

1. Remove hardware from box and sort by size.
2. Please check to see that all hardware and parts are present prior to start of assembly.
3. Please follow attached instructions in the same sequence as numbered to assure fast & easy assembly.



## WARNING!

1. Don't attempt to repair or modify parts that are broken or defective. Please contact the store immediately.
2. This product is for home use only and not intended for commercial establishments.

ASSEMBLY TIME 40 MINUTES

## PARTS IDENTIFICATION

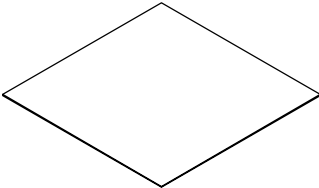
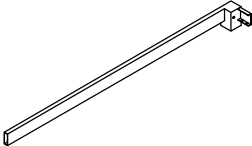
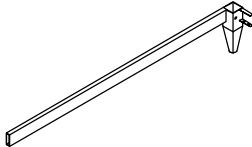
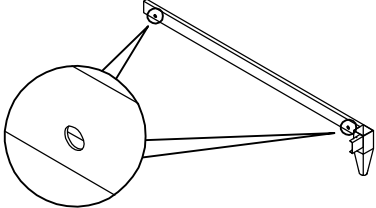
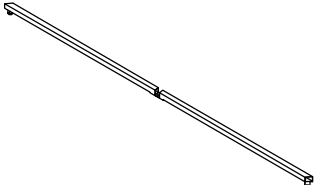
A	TOP		1PC
B	TOP CROSSBAR		4PCS
C	BOTTOM CROSSBAR 1		2PCS
D	BOTTOM CROSSBAR 2		2PCS
E	SUPPORT CROSSBAR 1		1PC

# ASSEMBLY INSTRUCTIONS

## PARTS IDENTIFICATION

F

SUPPORT CROSSBAR 2

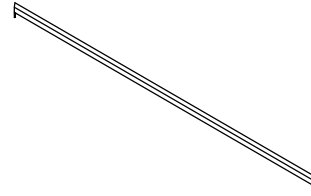

1PC

G

LEG

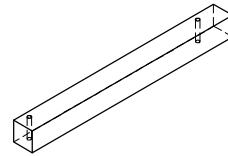

4PCS

Z

## HARDWARE IDENTIFICATION

1

SHORT BOLT  
(1/4" x 9mm SR)



21PCS

4

SUCTION CUP



4PCS

2

LONG BOLT  
(1/4" x 35mm SR)



8PCS

5

COVER



8PCS

3

CAP  
( $\phi$ 18mm BLK)



4PCS

6

ALLEN WRENCH  
(4mm)



1PC

# ASSEMBLY INSTRUCTIONS

**STEP 1** Do not tighten until each step is completed or instructed.

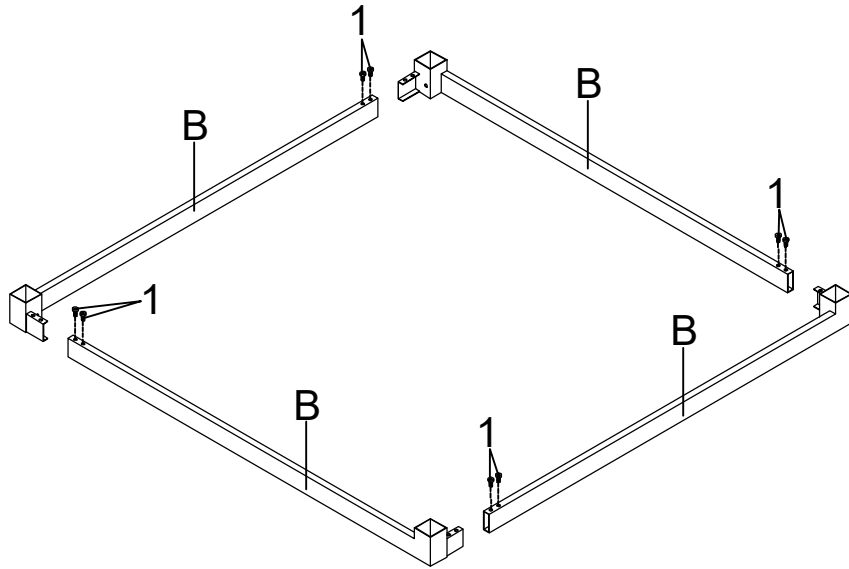

## STEP 2

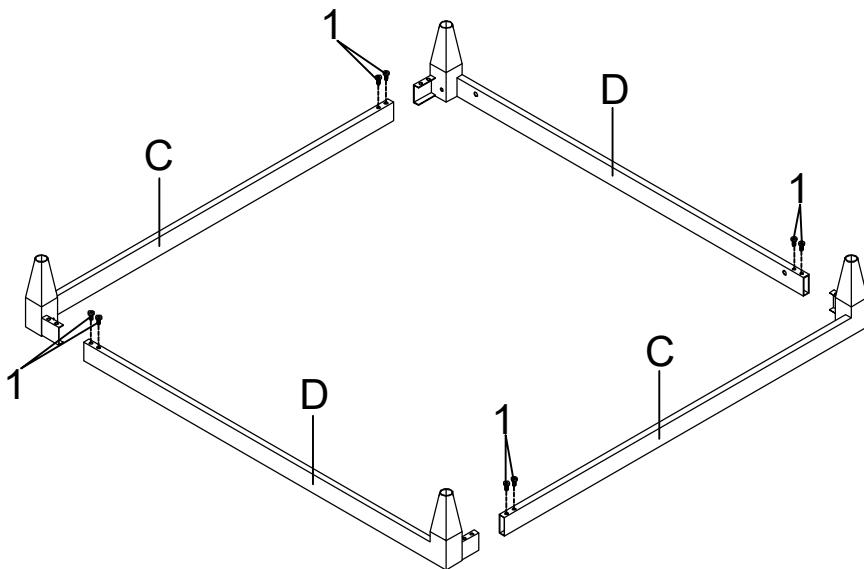

# ASSEMBLY INSTRUCTIONS

## STEP 3

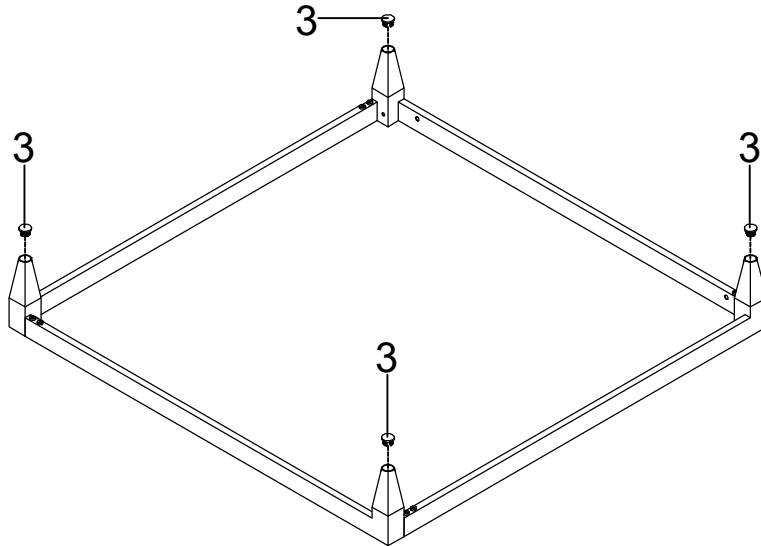

## STEP 4

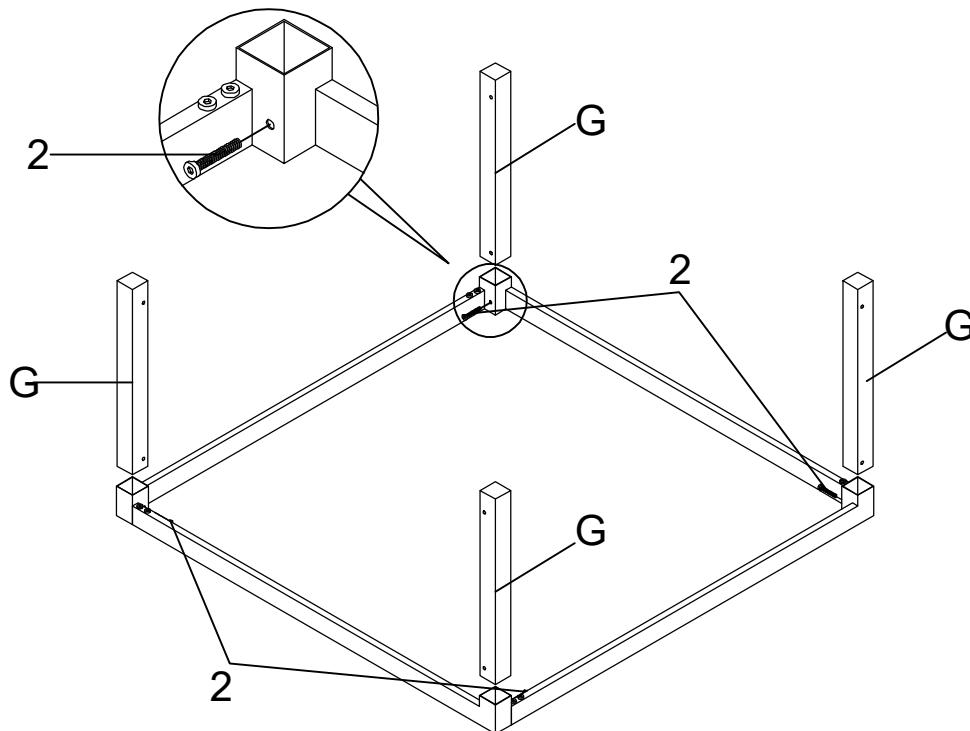

# ASSEMBLY INSTRUCTIONS

## STEP 5

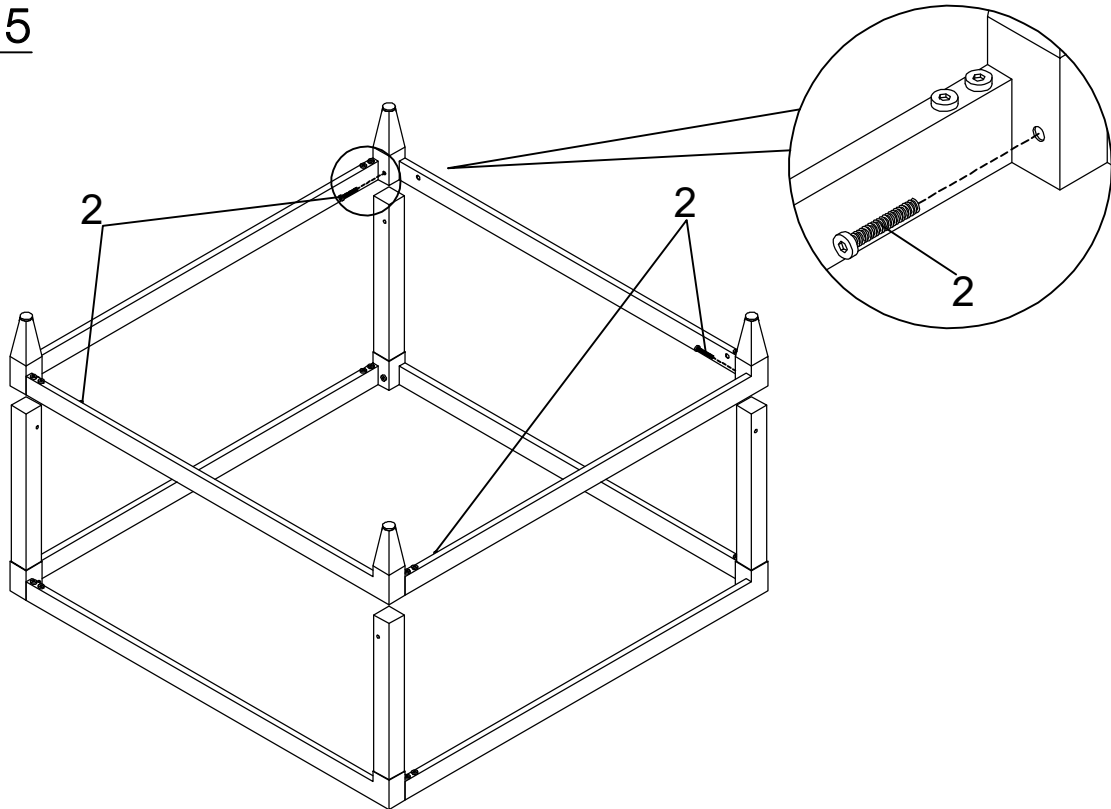

## STEP 6

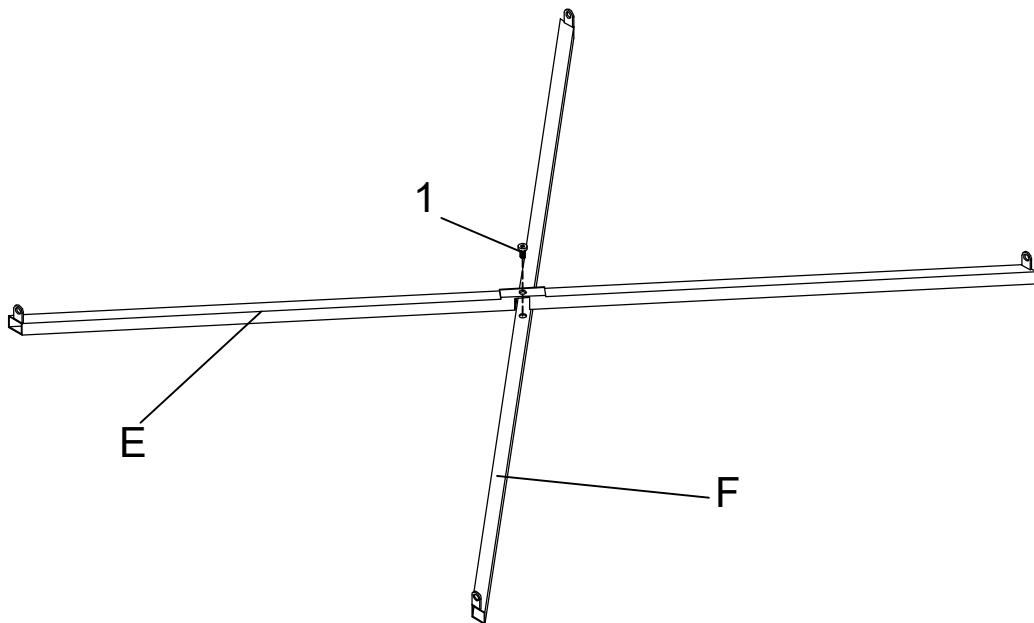

# ASSEMBLY INSTRUCTIONS

## STEP 7

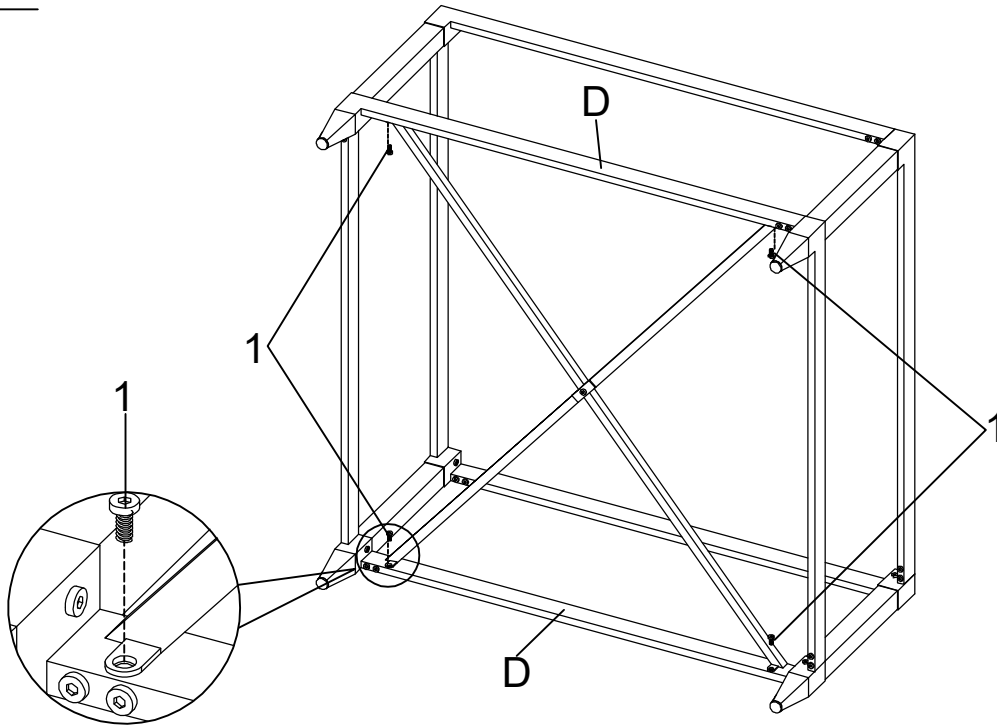

## STEP 8

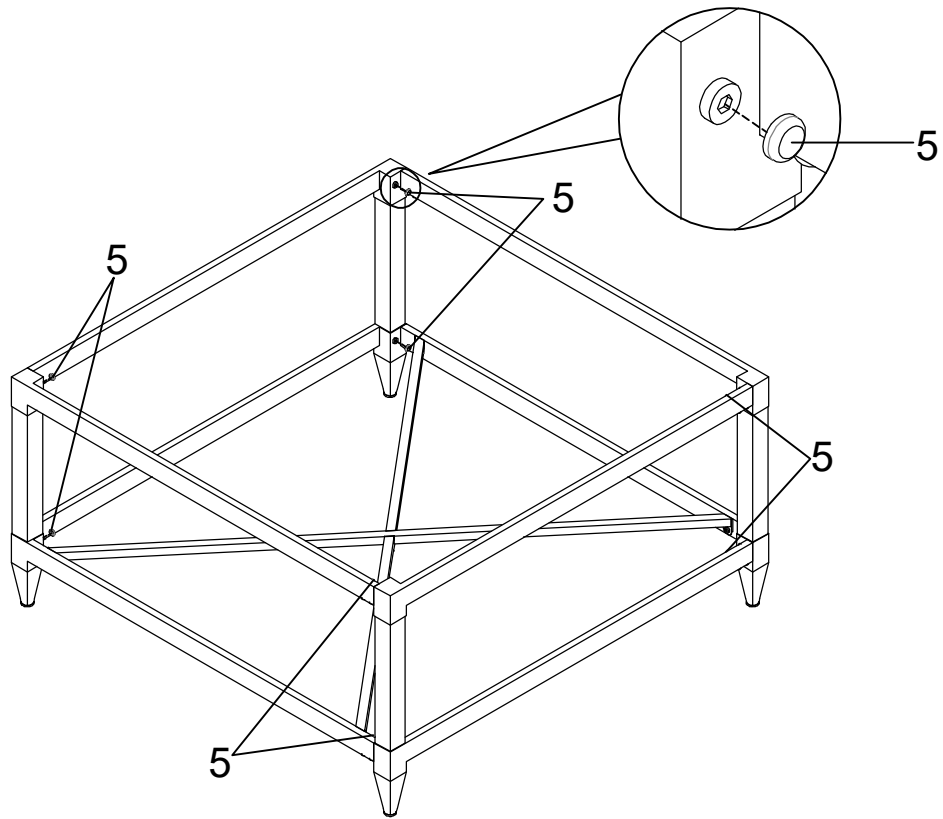

# ASSEMBLY INSTRUCTIONS

## STEP 9

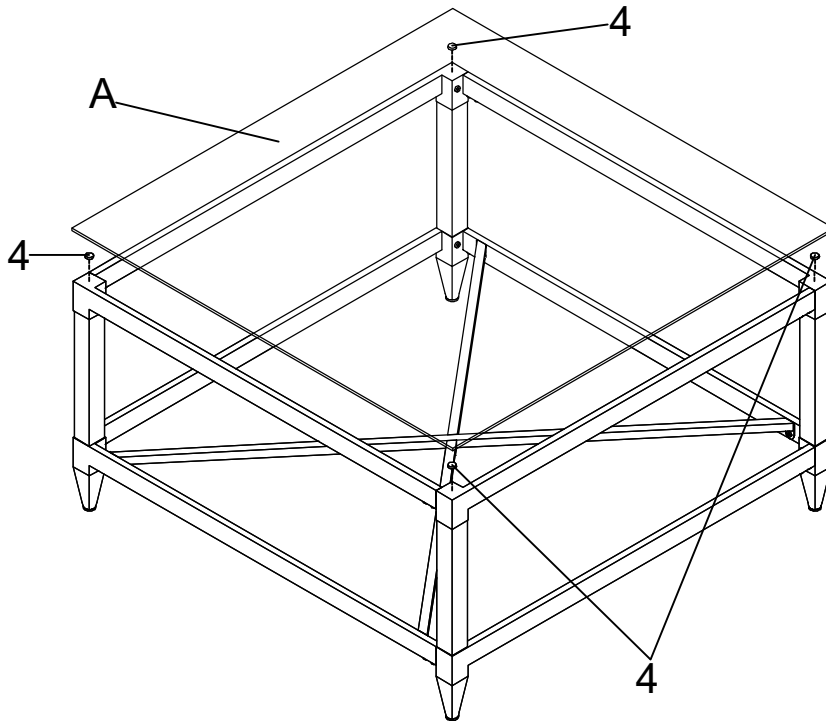

## STEP 10

### COMPLETE

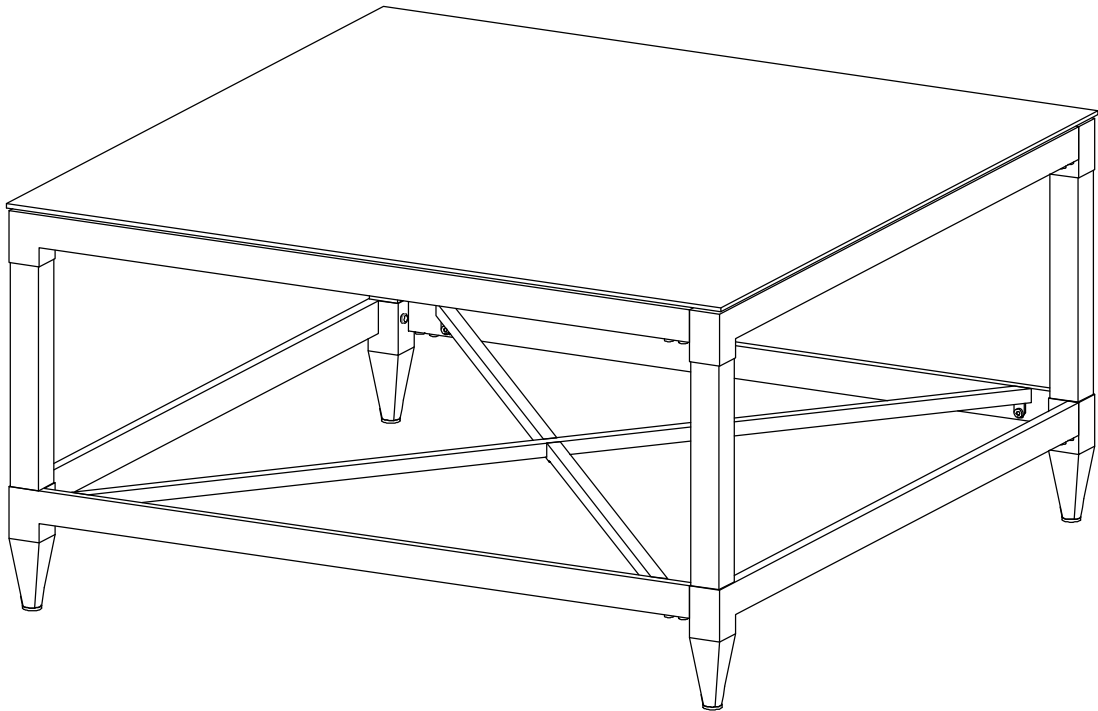

How to clean Acrylic product:  
Using a dry soft microfiber cloth, lightly brush off any dust.  
For additional care, dampen the cloth with warm water.  
For deepest cleaning, use an Acrylic cleaner.

# ASSEMBLY INSTRUCTIONS

**Product Size : 900 X 900 X 457 H (MM)**

**Product Size : 35.25" X 35.25" X 18"**

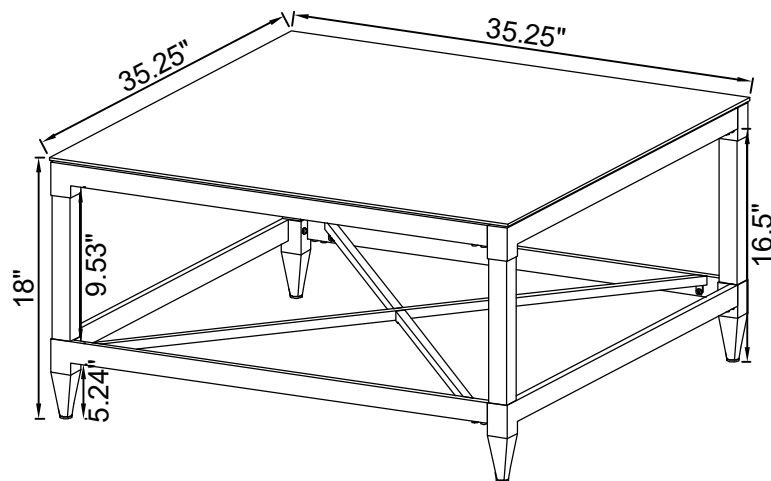

Note : Dimension tolerance  $\pm 5\%$