

MOCR215

15" CRESCENT ICE MAKER



MARVEL OUTDOOR COLLECTION

MAIN FEATURES

- Produces and stores up to 25 lbs of crescent ice per day
- Removable ice bin
- No pump or drain required
- Crescent ice dimensions: 1/2 W x 3/4 H x 2-1/4 L
- On / Off switch at the front of the unit
- Arctic white interior
- Reversible door allows for right or left swing
- Designed for outdoor use

WARRANTY

- 1-year parts and labor warranty and 5-year sealed system parts warranty (see complete warranty for details)

FINISH OPTIONS



DOOR STYLE	MODEL NUMBER
Solid Stainless Steel	MOCR215-SS01B



DIMENSIONAL DRAWINGS

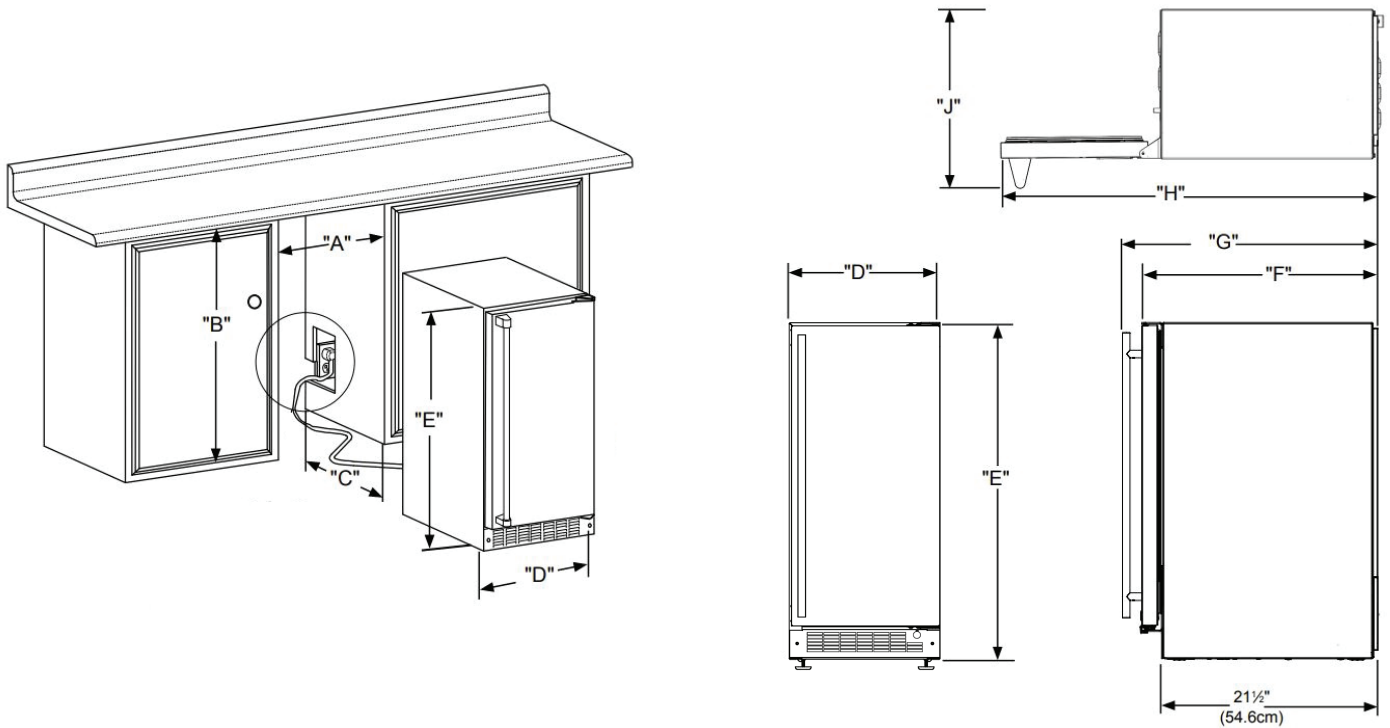

ROUGH IN DIMENSIONS*

"A"	"B"	"C"
15"	34-1/4" to 35-1/4"	24"
(38.1 cm)	(87 cm to 89.5 cm)	(61 cm)

CABINET DIMENSIONS*

"D"	"E"	"F"	"G"	"H"	"J"
14-7/8"	34-1/8" to 35-1/8"	23-5/8"*	24-1/8"*	38-3/4"*	17-1/2"*
(37.8 cm)	(86.7 cm to 89.2 cm)	(60 cm)	(61.3 cm)	(98.4 cm)	(44.4 cm)

*Stainless steel model dimensions only. For panel-ready models, see the owner's guide online at marvelrefrigeration.com.

PRODUCT SPECIFICATIONS

Capacity	25 LBS
Cord Length	6 FT.
Electrical Requirements	115V / 60 Hz / 15A
ENERGY STAR	No
Refrigerant Type	R600a
Sabbath Mode	No
Shipping Dimensions	19" W x 31" D x 37" H
Shipping Weight	25 LBS

