

ASSEMBLY INSTRUCTIONS



Fine Furniture for every stage of life

TV CONSOLE

REVISION 0 : 05/07/2014
REVISION 1 : 12/17/2018
REVISION 2 : 09/25/2019
REVISION 3 : 04/27/2022

REVISION 4 : 09/05/2022

PAGE 1 OF 12

ASSEMBLY INSTRUCTIONS

ASSEMBLY TIPS:

1. Remove hardware from box and sort by size.
2. Please check to see that all hardware and parts are present prior to start of assembly.
3. Please follow attached instructions in the same sequence as numbered to assure fast & easy assembly.



WARNING!

1. Don't attempt to repair or modify parts that are broken or defective. Please contact the store immediately.
2. This product is for home use only and not intended for commercial establishments.







ASSEMBLY TIME

60 MINUTES

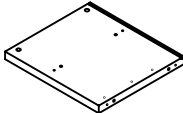
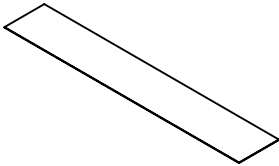
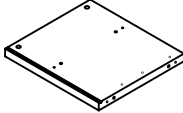
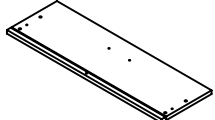
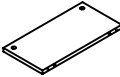
MAX TV SIZE : 65"

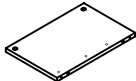
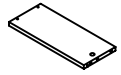
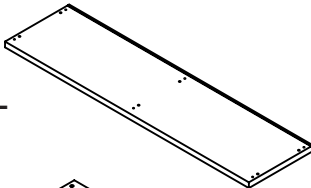
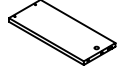
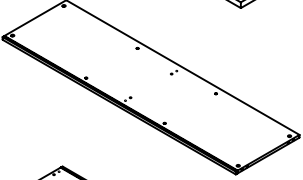
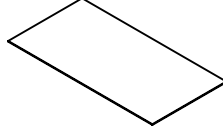
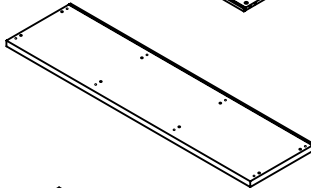
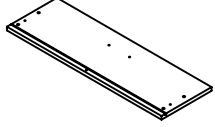
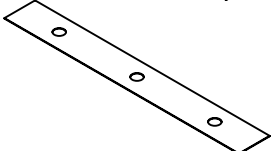
PARTS IDENTIFICATION

A	LEFT SIDE PANEL		1 PC	I	LOWER BACK PANEL		1 PC
B	RIGHT SIDE PANEL		1 PC	J	LEFT DRAWER FRONT PANEL		1 PC
C	UPPER DIVIDER PANEL		2 PCS	K	DRAWER BACK PANEL		2 PCS
D	LOWER DIVIDER PANEL		1 PC	L	LEFT DRAWER SIDE PANEL		2 PCS
E	BOTTOM PANEL		1 PC	M	RIGHT DRAWER SIDE PANEL		2 PCS
F	CROSS PANEL		1 PC	N	DRAWER BOTTOM PANEL		2 PCS
G	TOP PANEL		1 PC	O	RIGHT DRAWER FRONT PANEL		1 PC
H	UPPER BACK PANEL		1 PC	P	DRAWER SUPPORT		2 PCS

NOTE:

Phillips head screw driver is required in the assembly process; however, manufacturer does not provide this item.

Q CROSS BAR

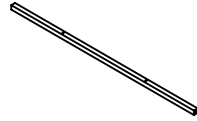

2 PCS

R FOOT

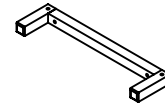

2 PCS

Z

HARDWARE IDENTIFICATION

NO	DESCRIPTION	FIGURE	Q'TY	NO	DESCRIPTION	FIGURE	Q'TY
1	GLUE 40g		1 PC	9	SHORT SCREW Ø 3x10mm SR		24 PCS
2	WOODEN DOWEL Ø 8x30mm		32 PCS	10	HANDLE L = 120mm		2 PCS
3	CAM BOLT Ø 7x35.5mm SR		20 PCS	11	HANDLE BOLT Ø 4x25mm RBW		4 PCS
4	CAM LOCK Ø 15x12mm SR		20 PCS	12	RUBBER Ø 52mm		3 PCS
5	LONG BOLT Ø 9.5x55mm SR		6 PCS	13	BOLT M6 x 42.5mm SR		8 PCS
6	BOLT Ø 4.5x42mm SR FOR BOTTOM PANEL		4 PCS	14	ALLEN WRENCH		1 PC
7	LONG SCREW Ø 4.3x35mm SR		14 PCS	15	STICKER Ø 20mm		4 PCS
8	RAIL L = 350mm WHT		2 SET				

Z8,Z10,Z12 not included in blister packaging.

NOTE:

Phillips head screw driver is required in the assembly process; however, manufacturer does not provide this item.

STEP 1

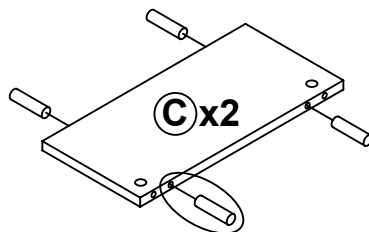
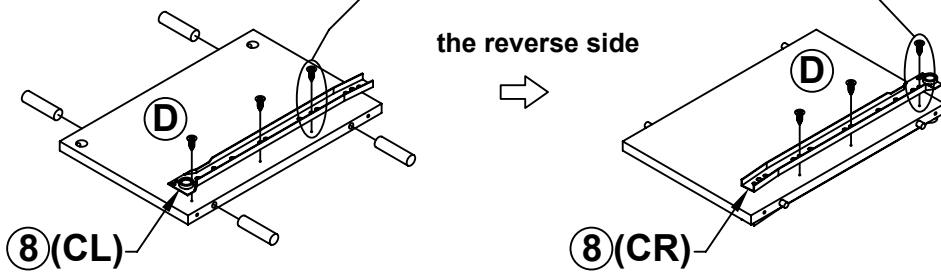
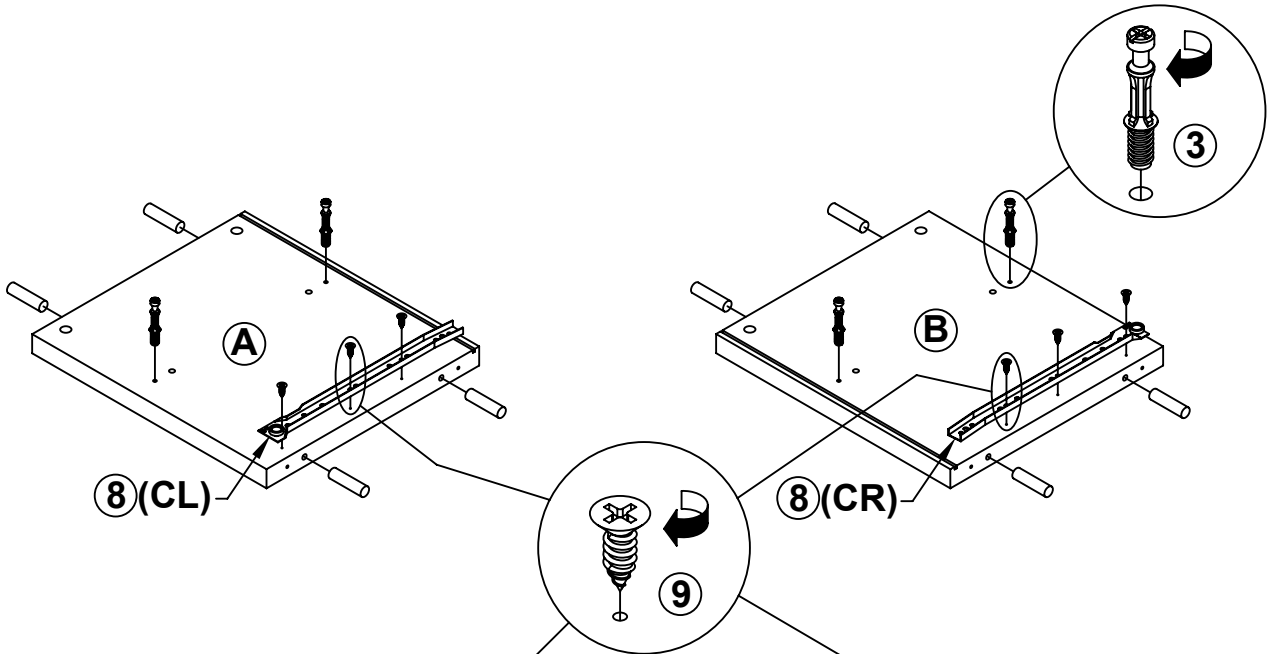
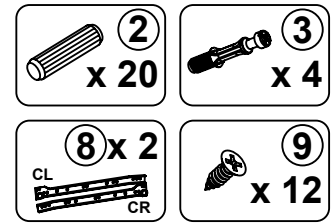

CORRECT
INCORRECT

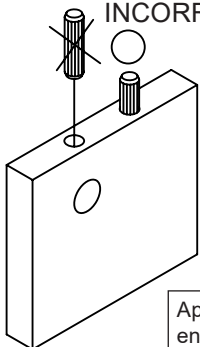

Apply glue on all wooden dowels to ensure integrity of the structure.

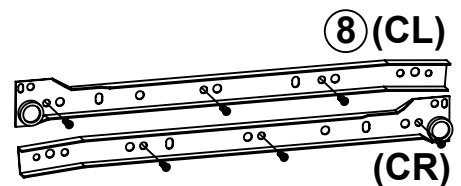
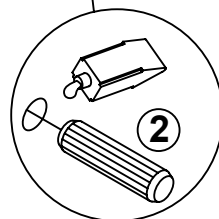

STEP 2

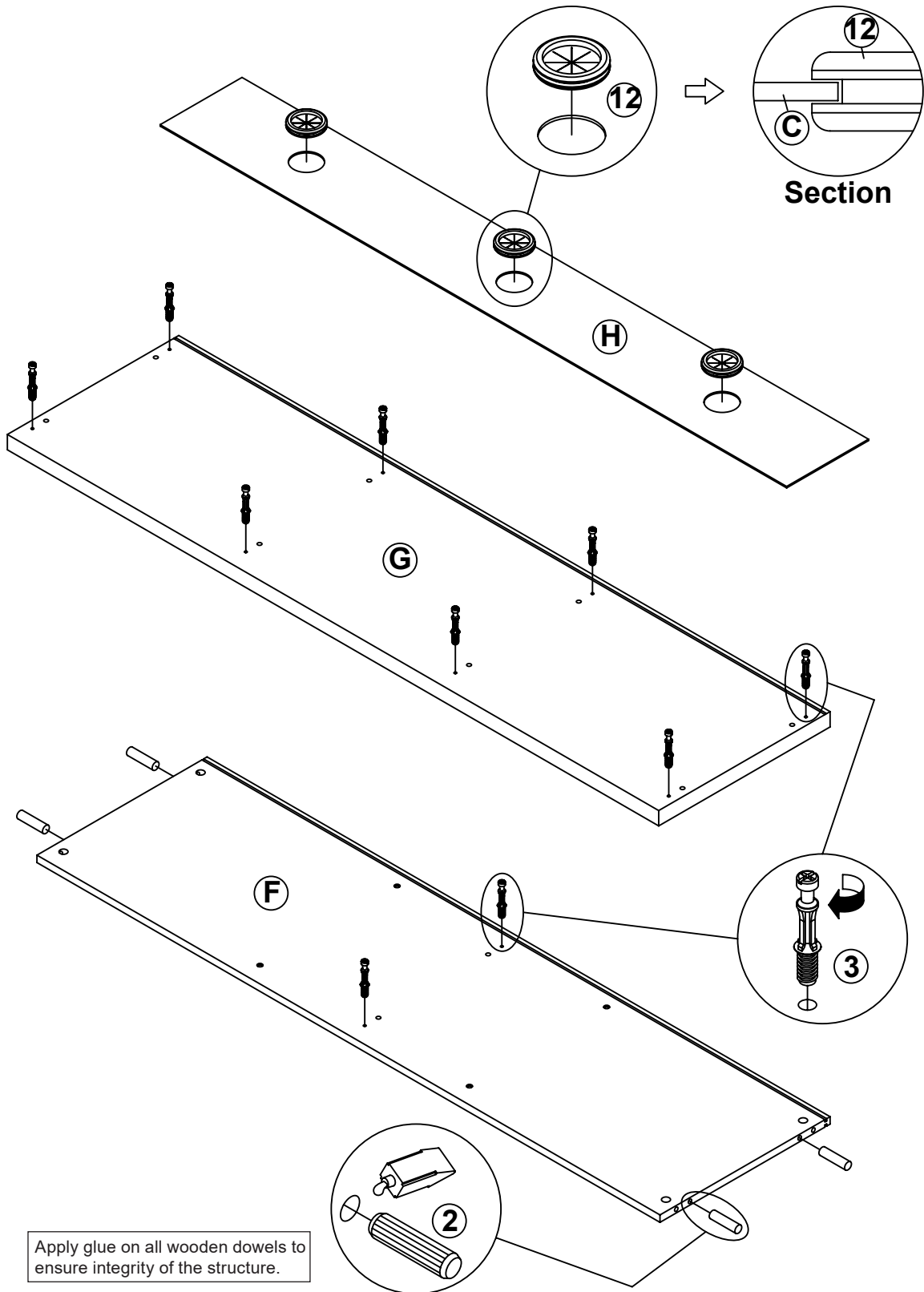
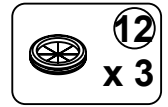
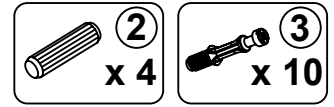

STEP 3

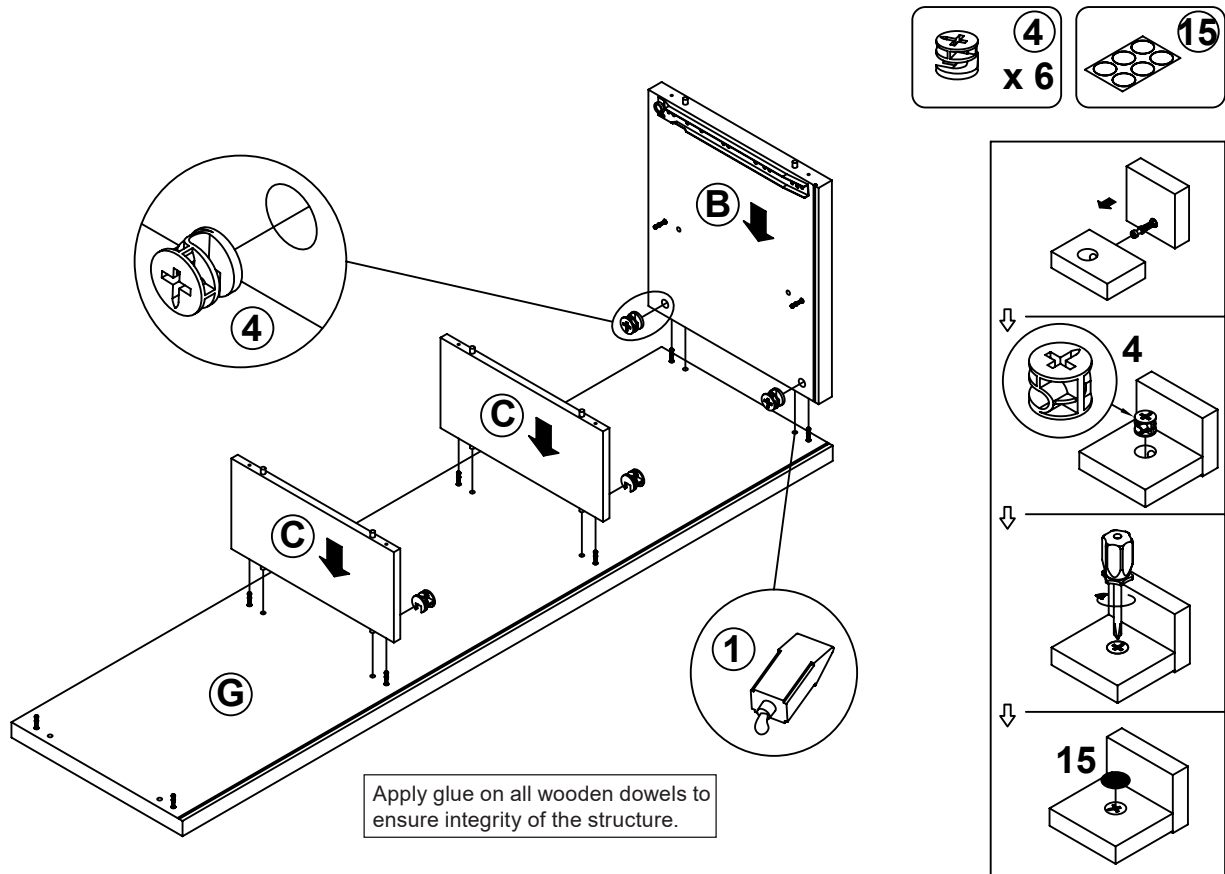

STEP 4

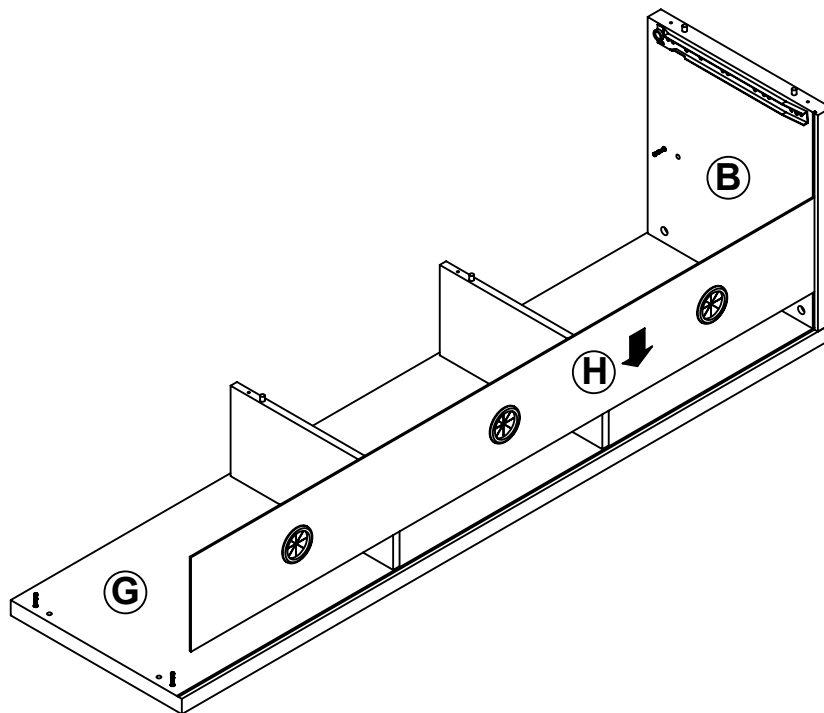

STEP 7

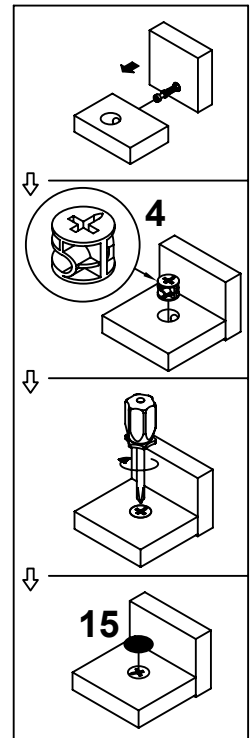
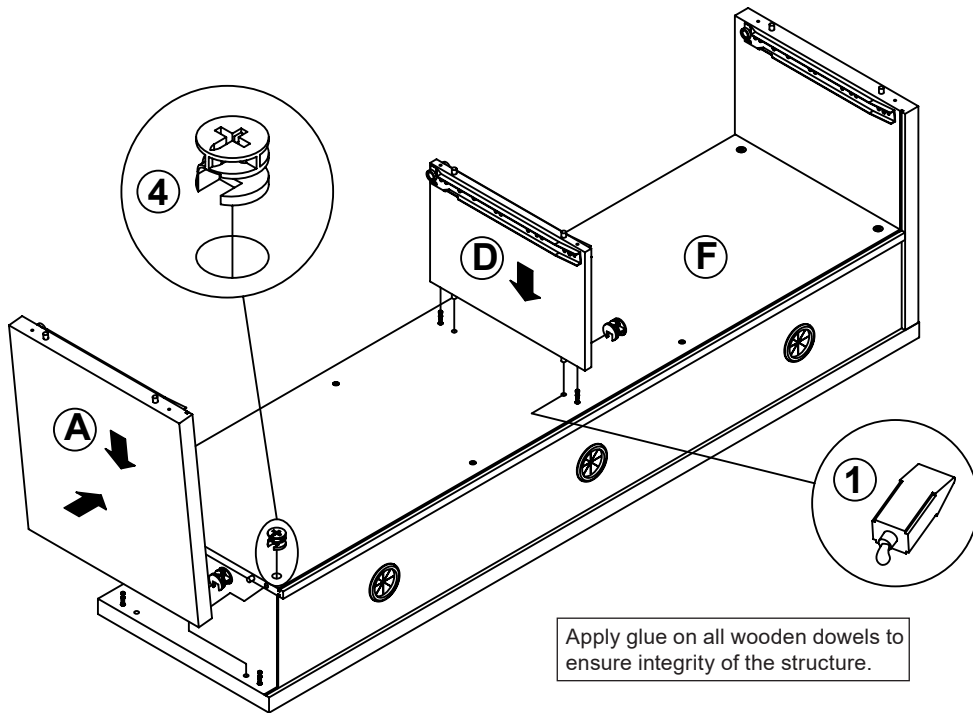
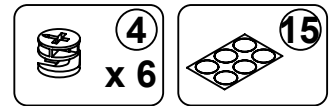

STEP 8

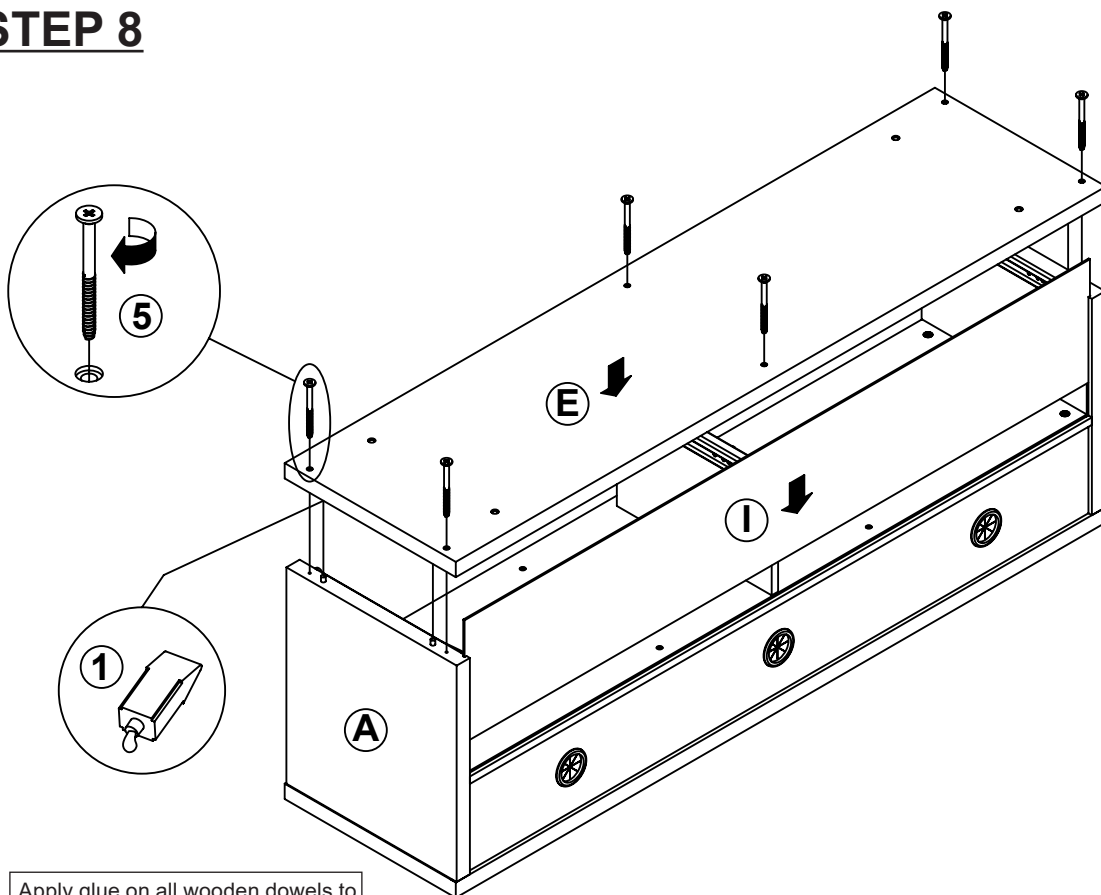
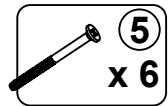

Apply glue on all wooden dowels to ensure integrity of the structure.

STEP 9

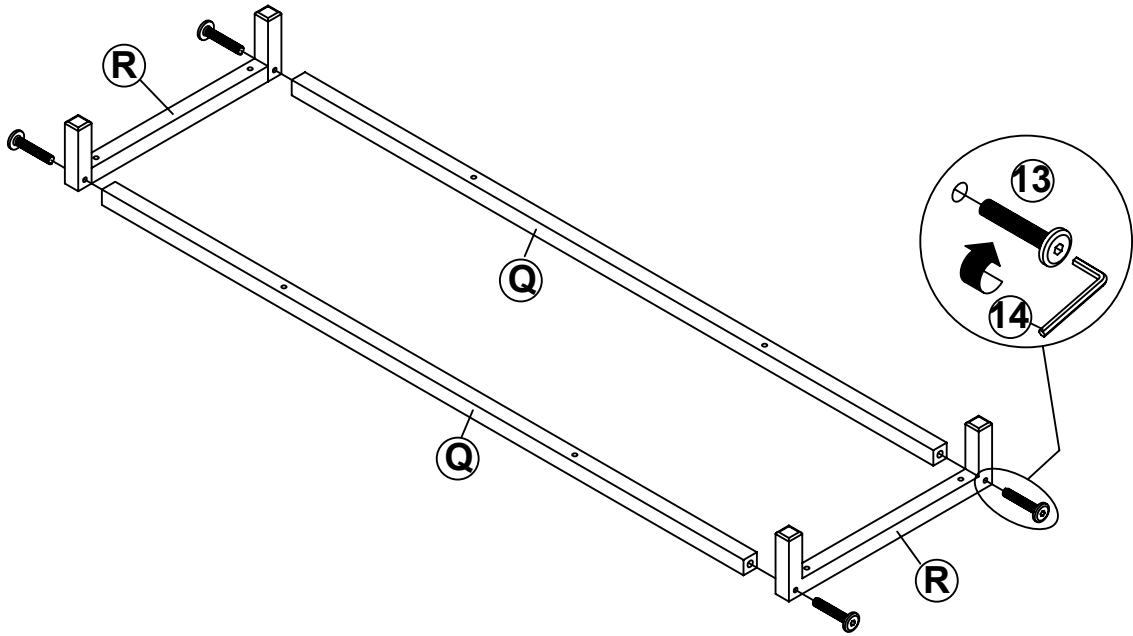
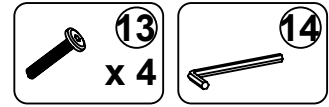

STEP 10

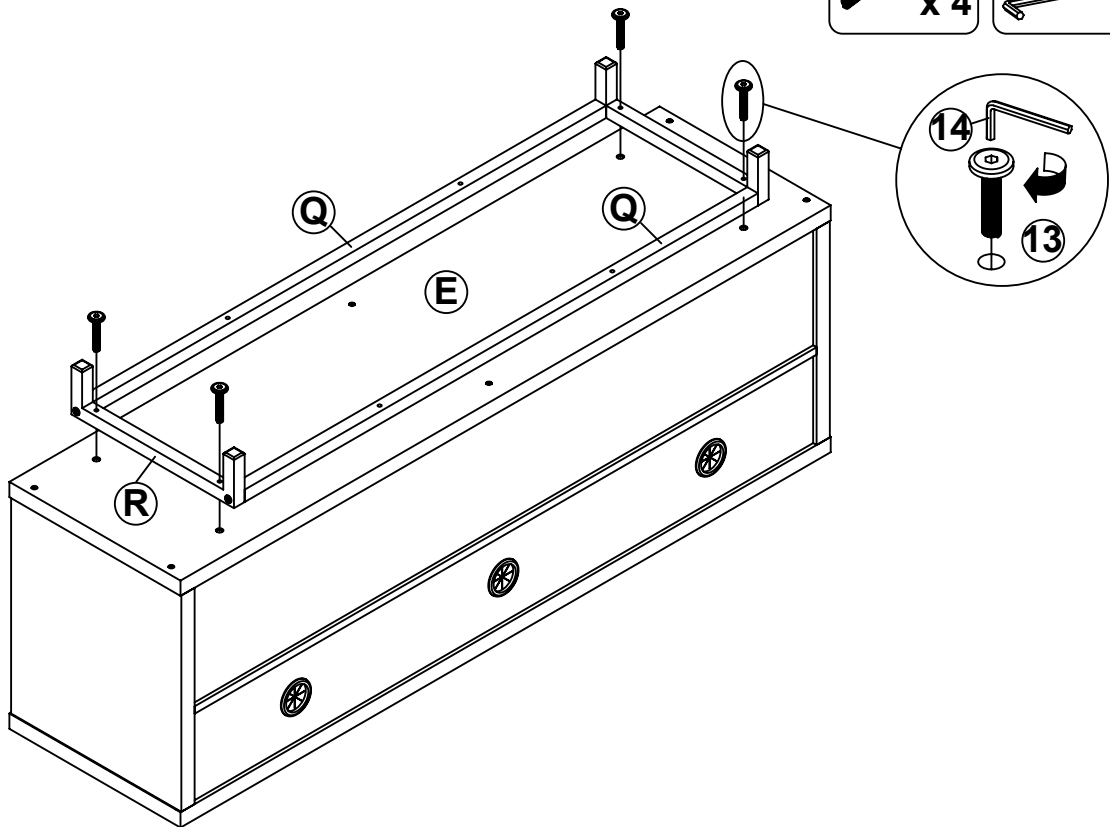

STEP 11

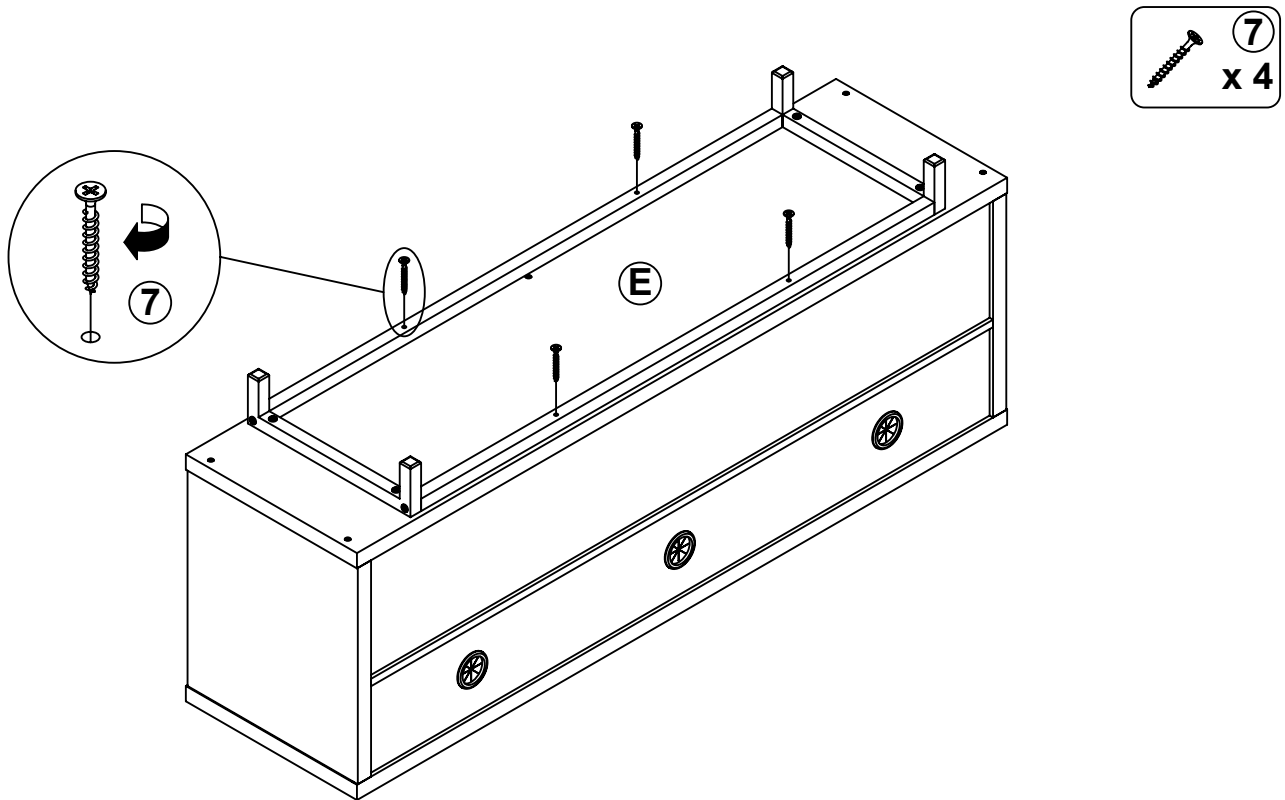

STEP 12

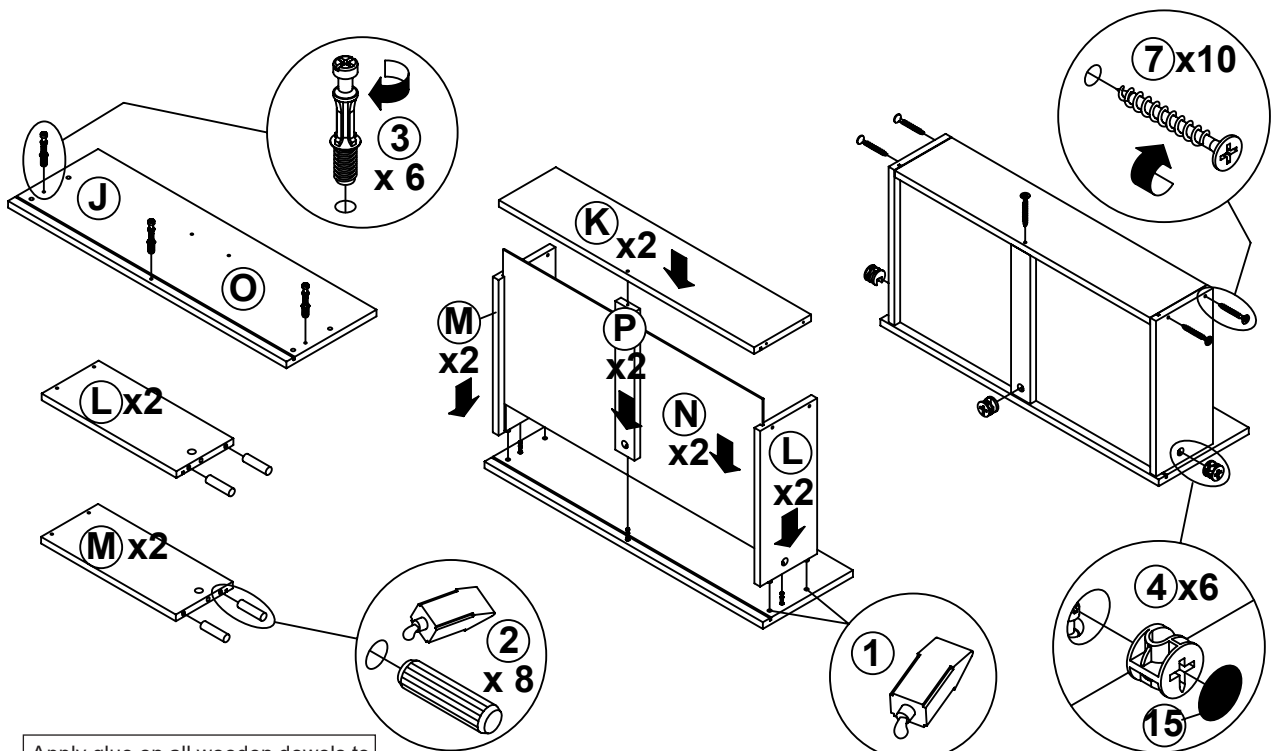

Apply glue on all wooden dowels to ensure integrity of the structure.

STEP 13

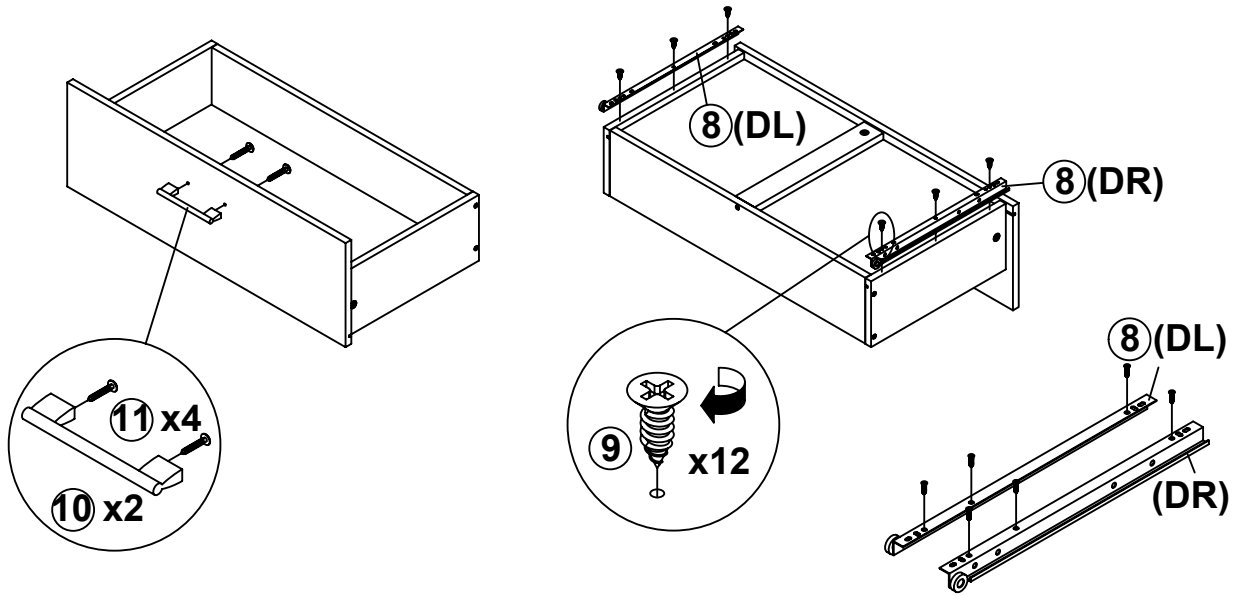

STEP 14

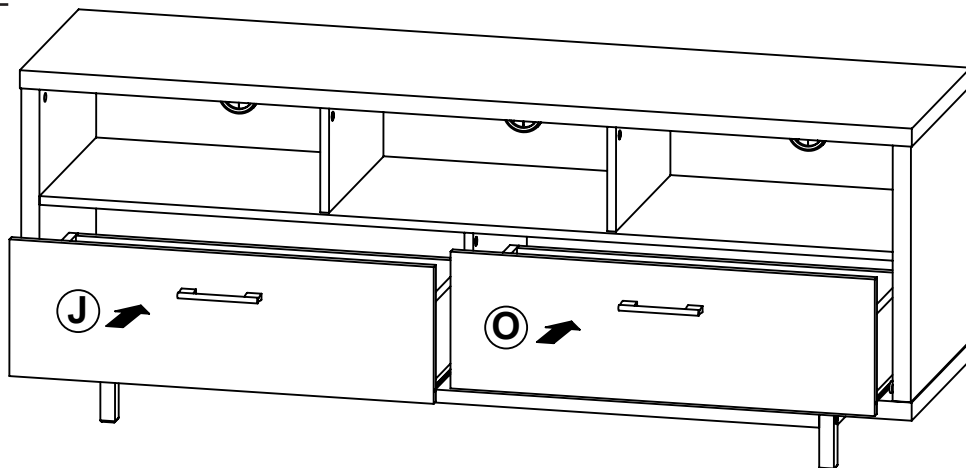

STEP 15

COMPLETE

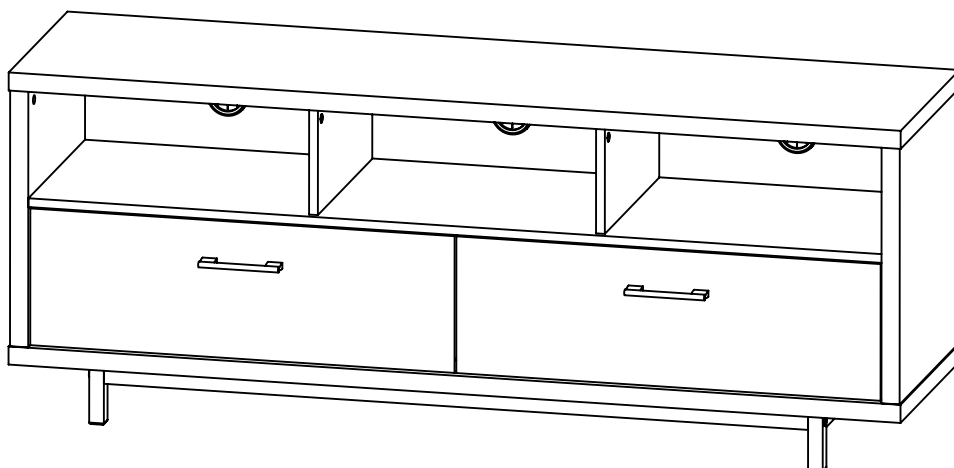

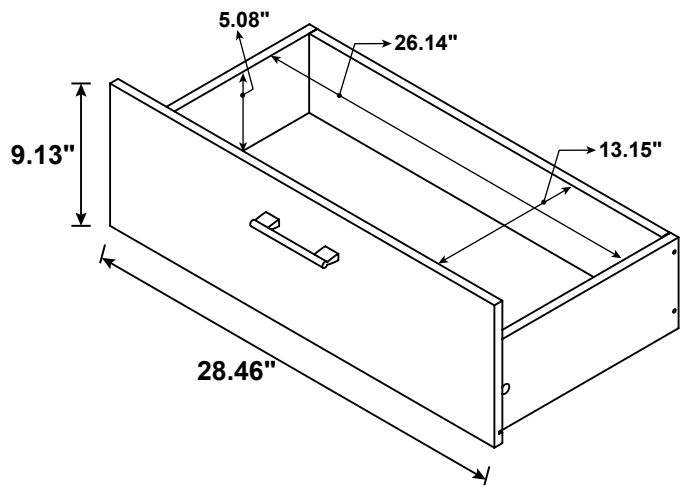
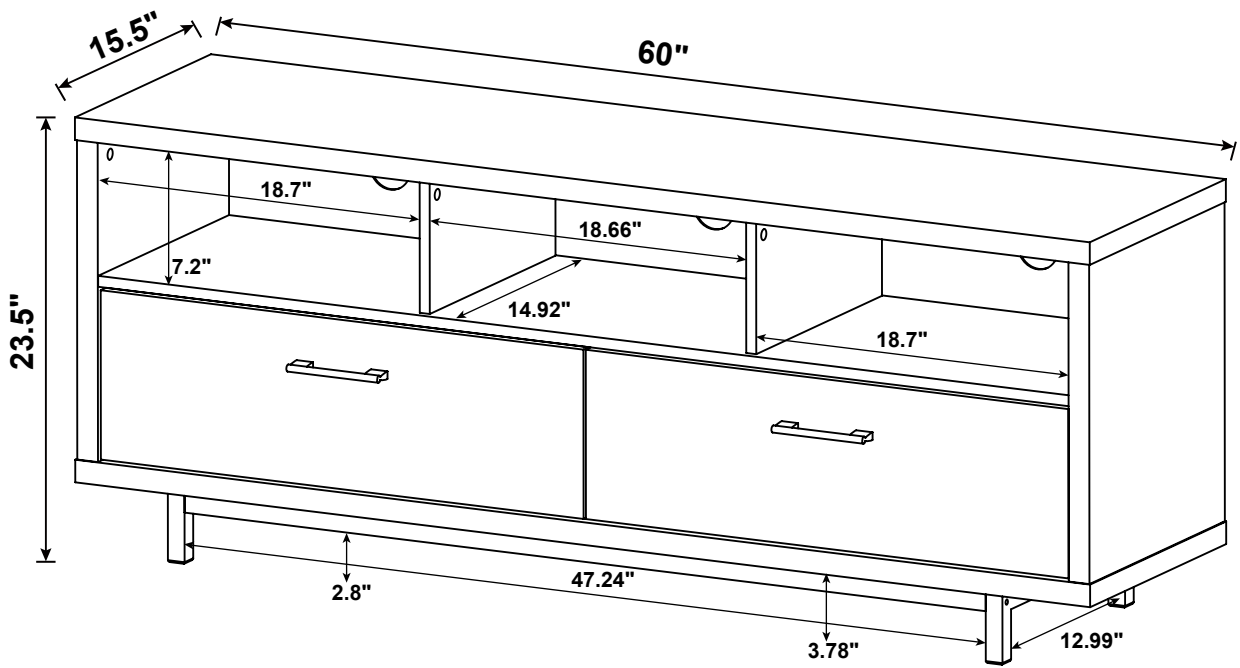

Note : Dimension tolerance $\pm 5\%$