

Not Provided

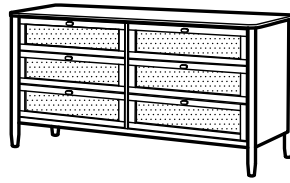

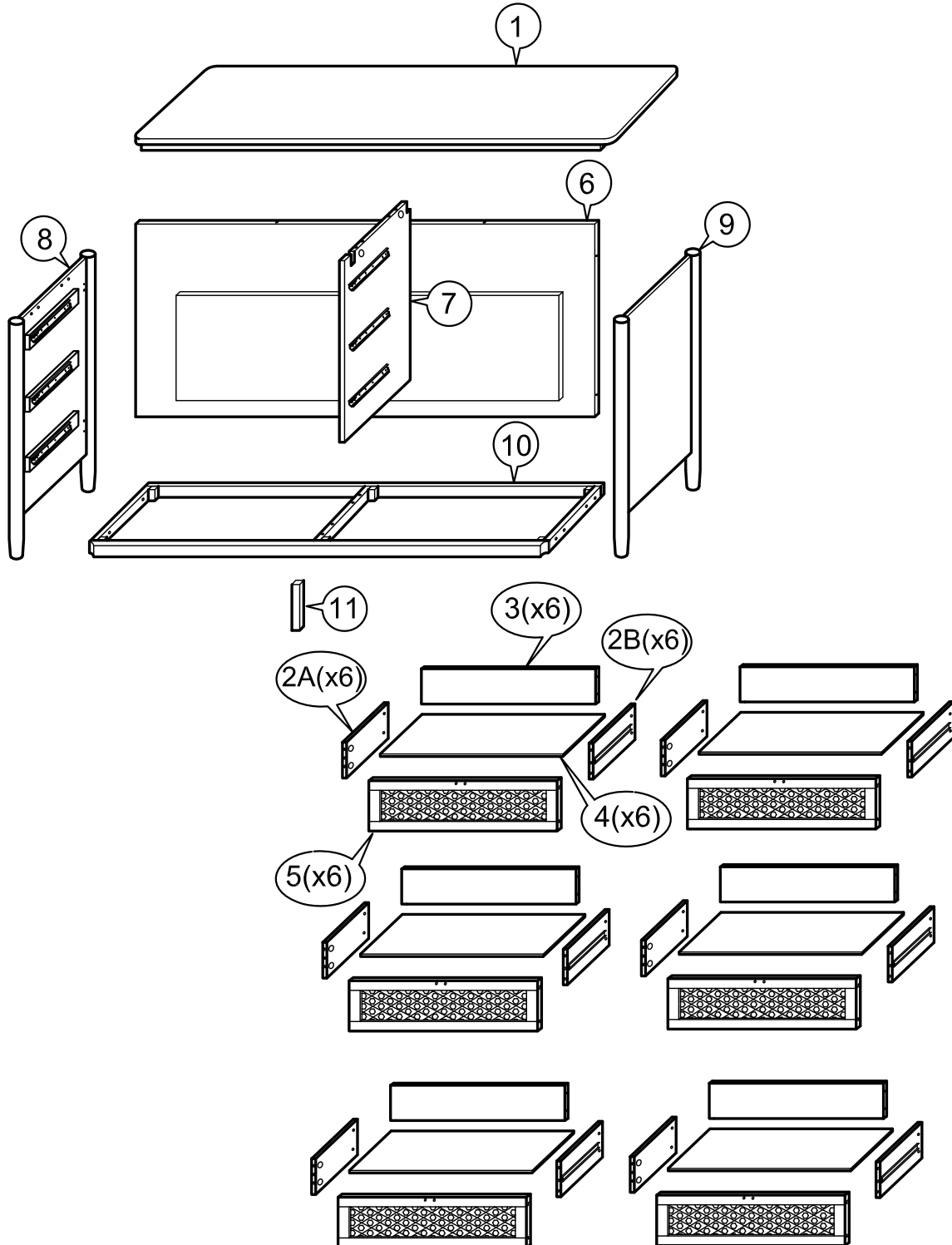







2 Persons



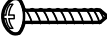

Part List :

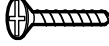
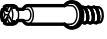

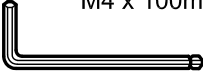
Hardware List

A M6 x 25mm = 8 	E M8 x 25mm = 28 	I M6 x 23mm = 1 	
B M6 x 13mm = 8 	F #8 x 1 1/4"(32mm) = 24 	J #8 x 1"(25mm) = 42 	
C 12mm = 32 	G 42 x 50 x 19 = 6 	K M4 x 38mm = 2 	
D 24mm = 32 	H M4 x 20mm = 12 	L M4 x 100mm = 1 	

ANTI-TIPPING WITH METAL STRAPE (2 SET)

			
---	---	--	---

1

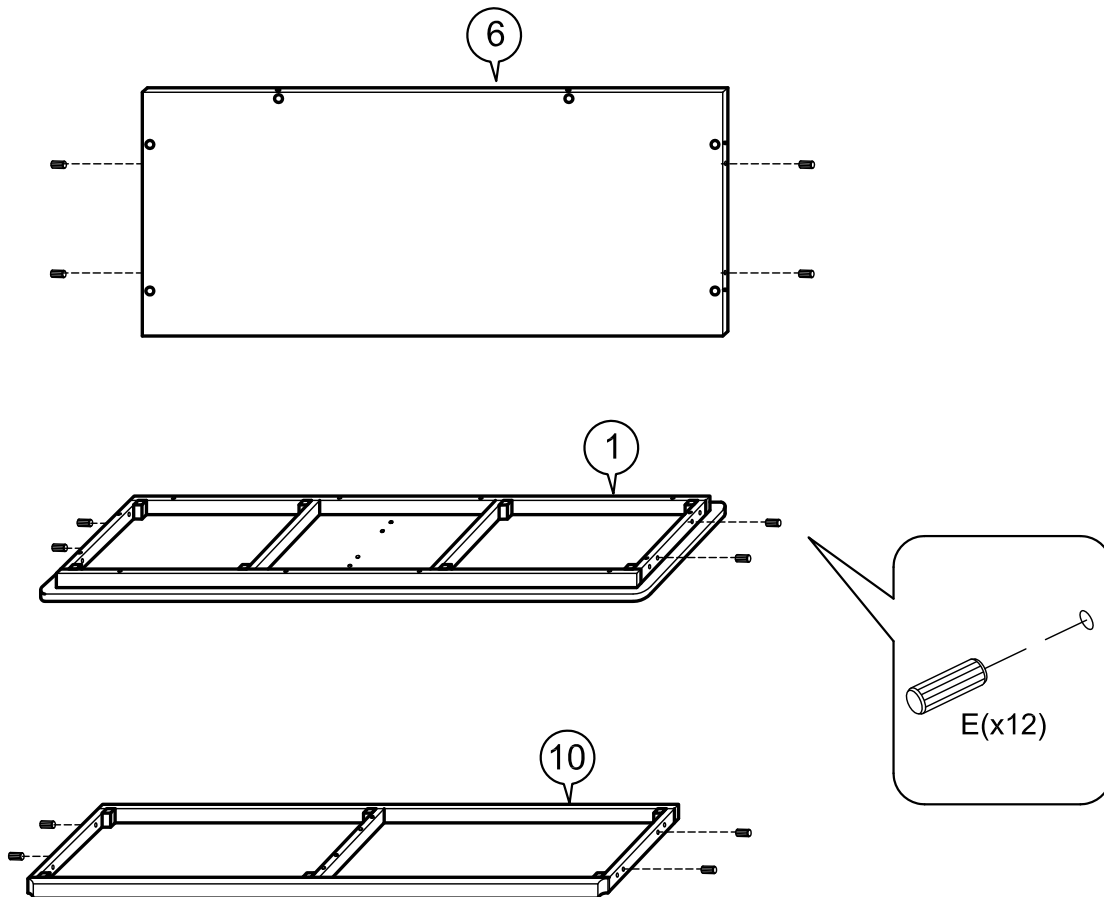

2

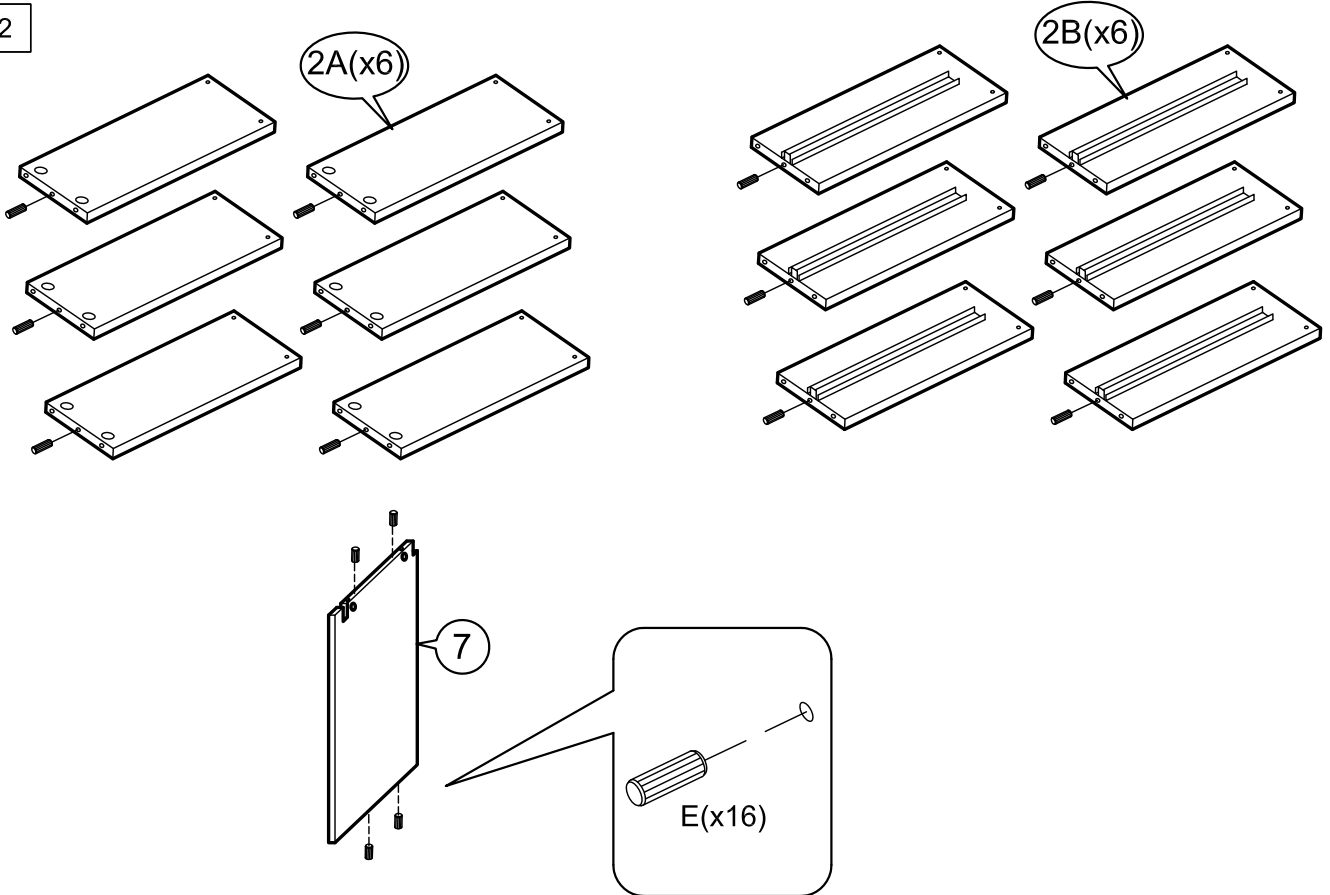

3

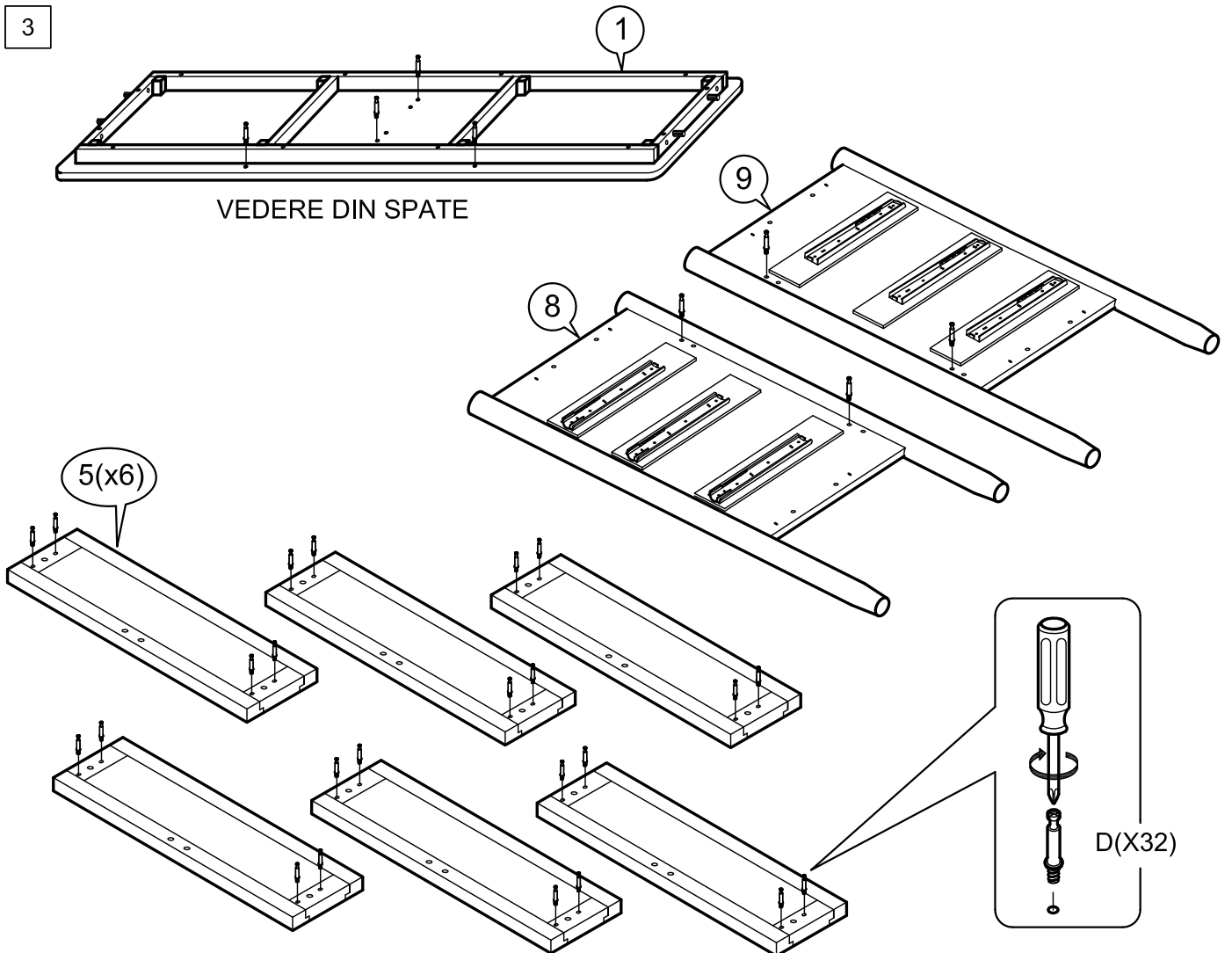

4

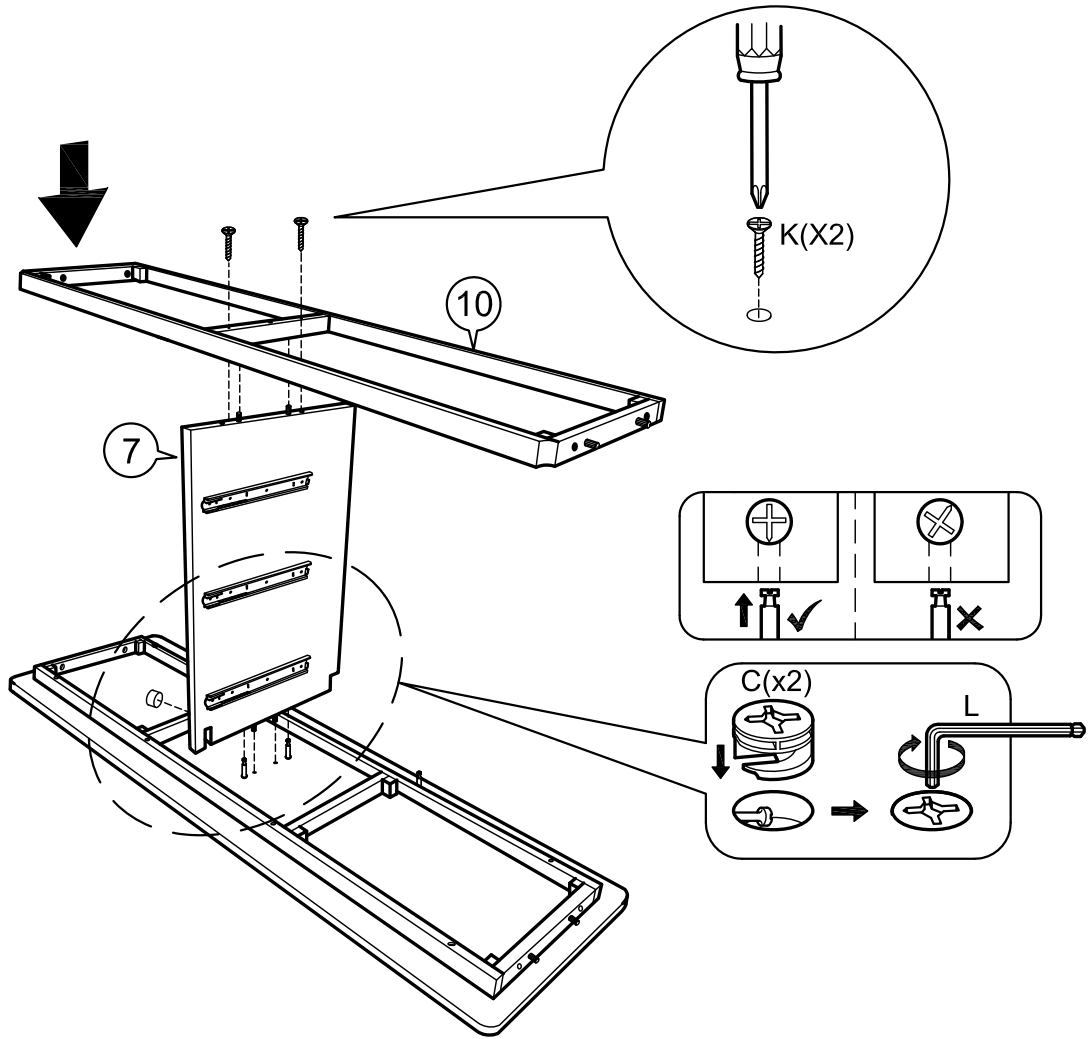

5

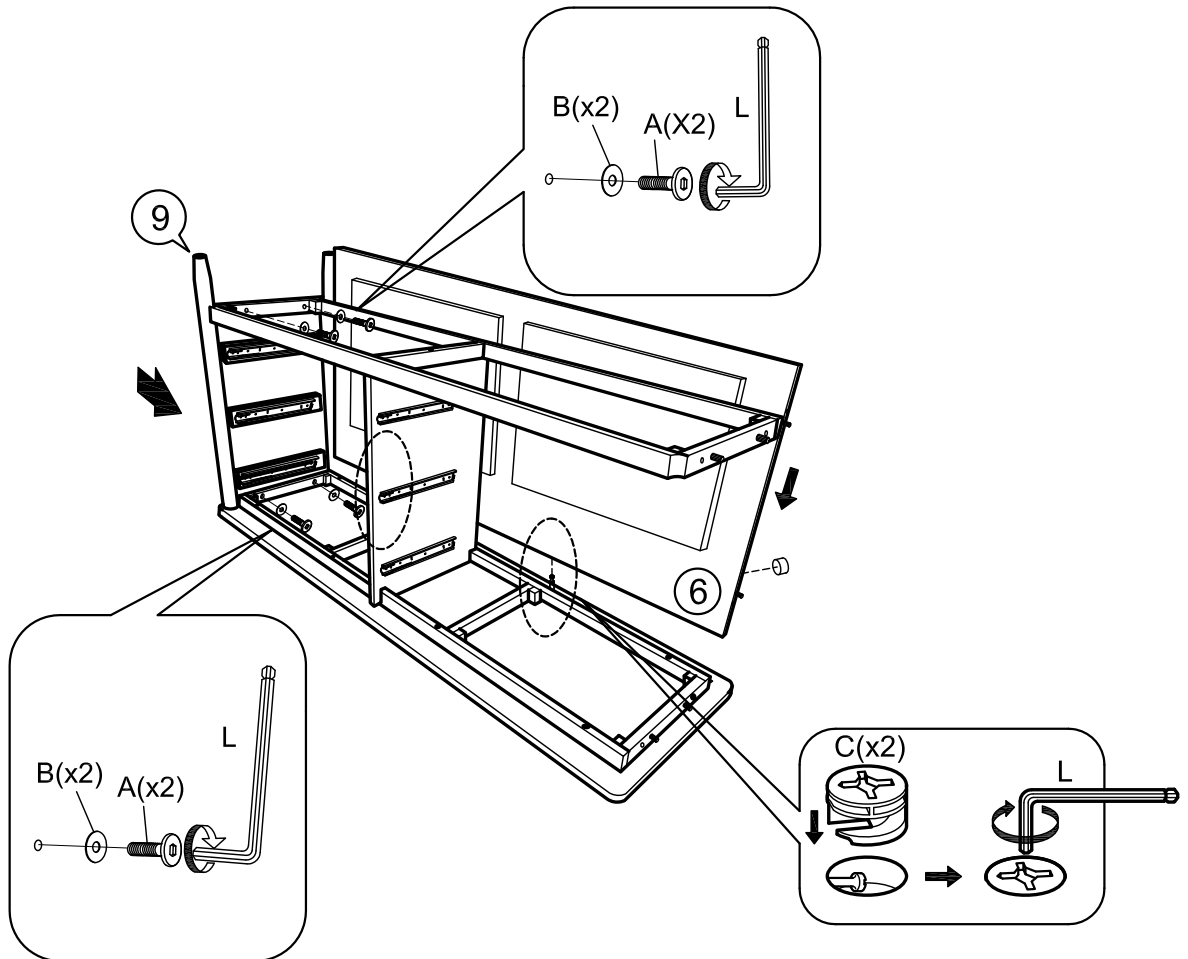

6

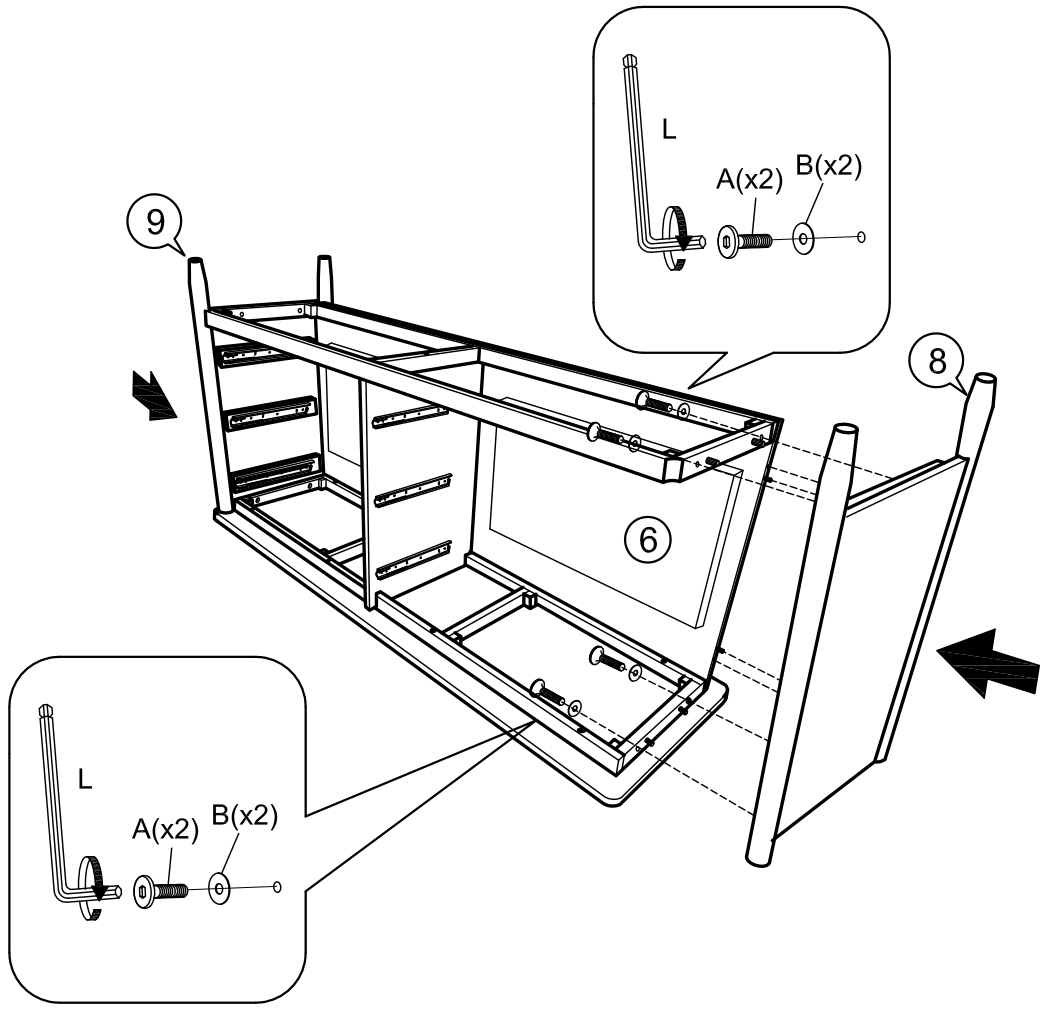

7

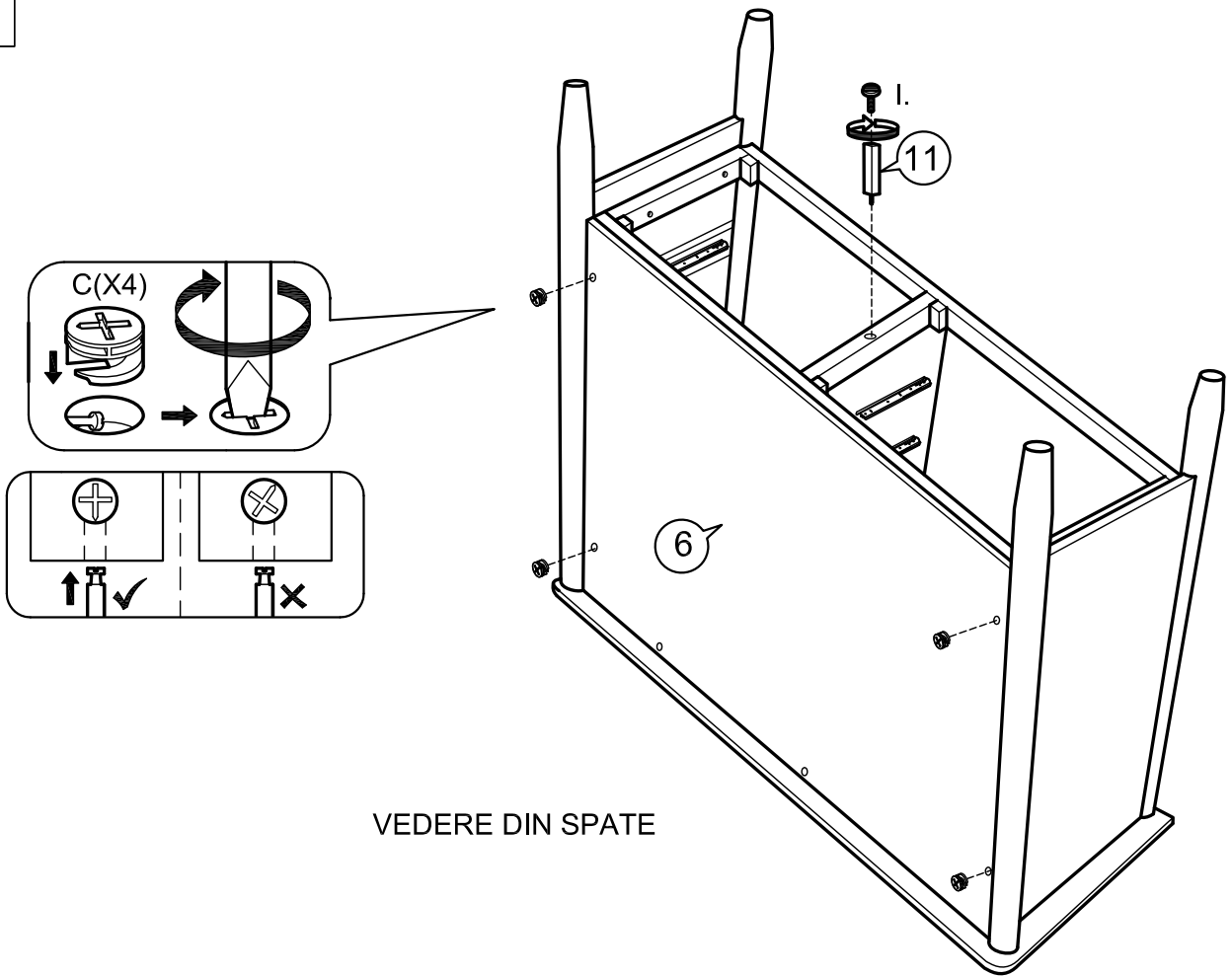

8

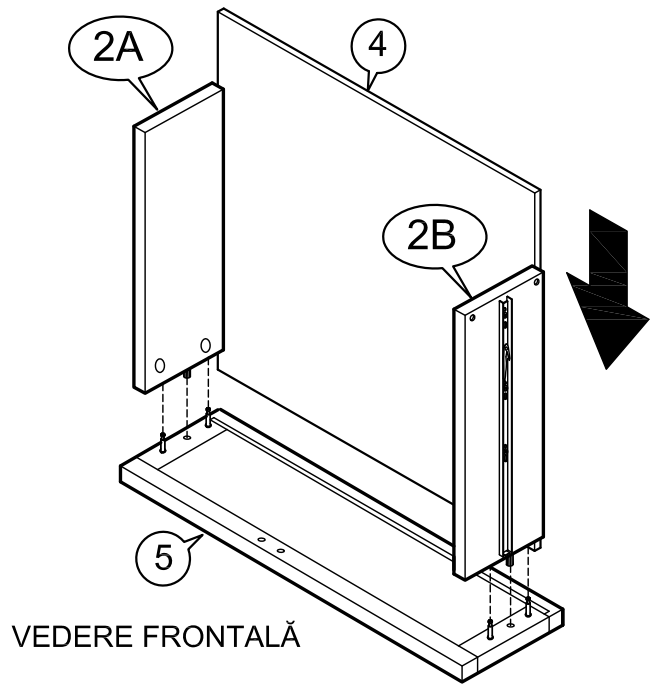

(X6)

9

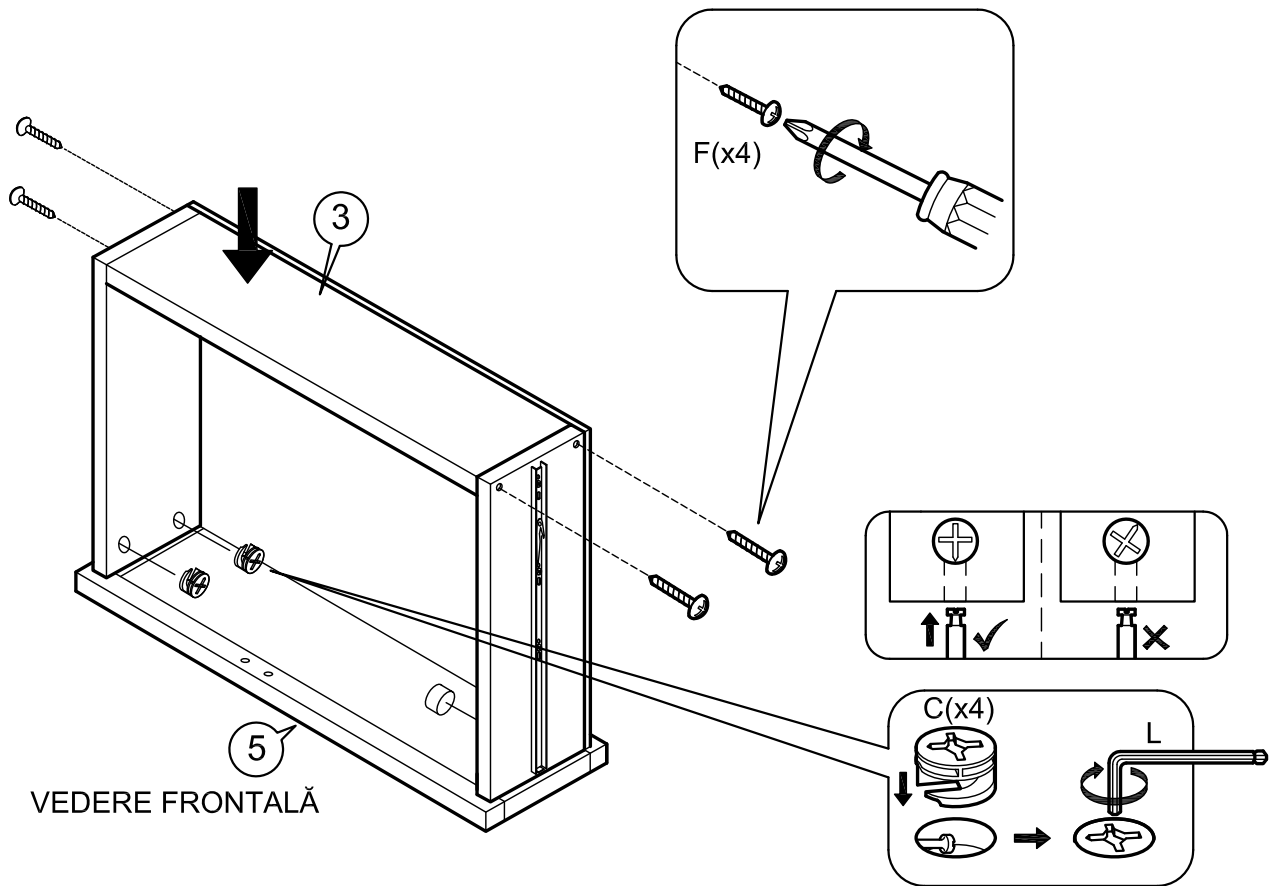

(X6)

10

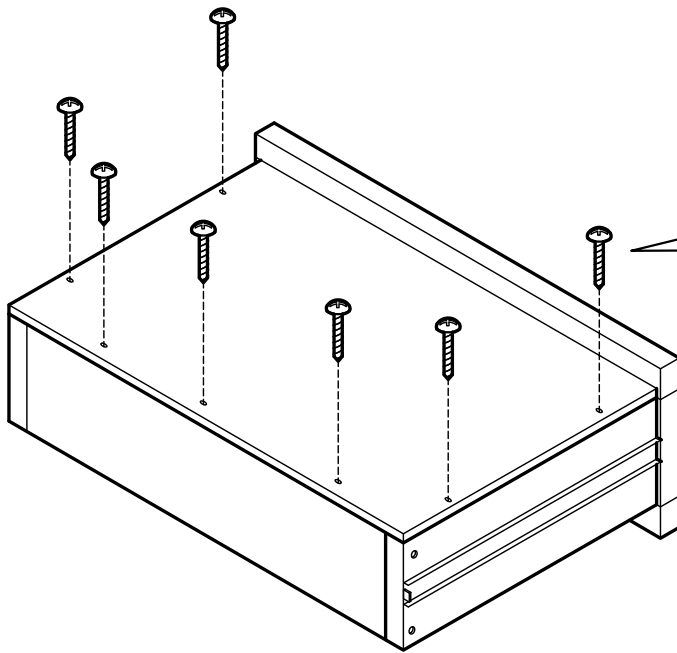

J(x7)

(X6)



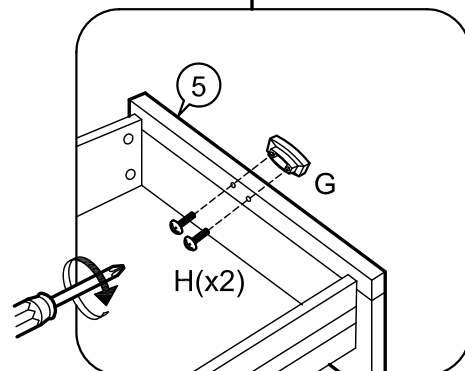
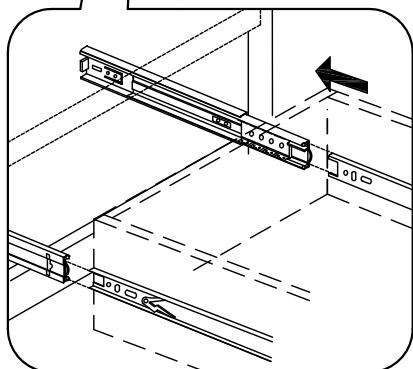
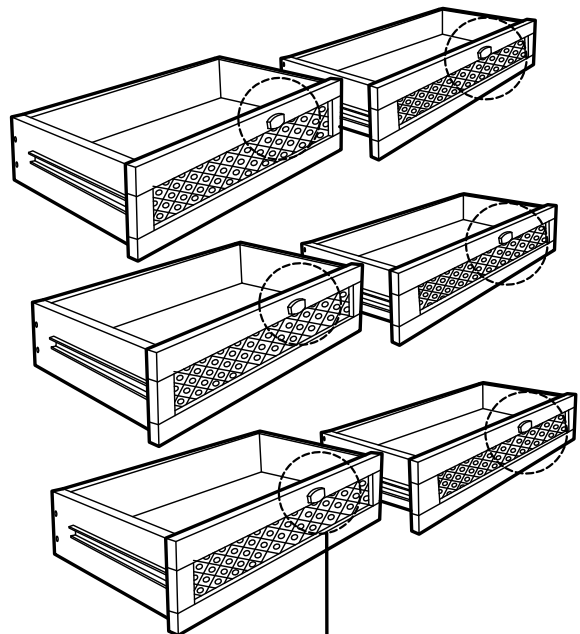
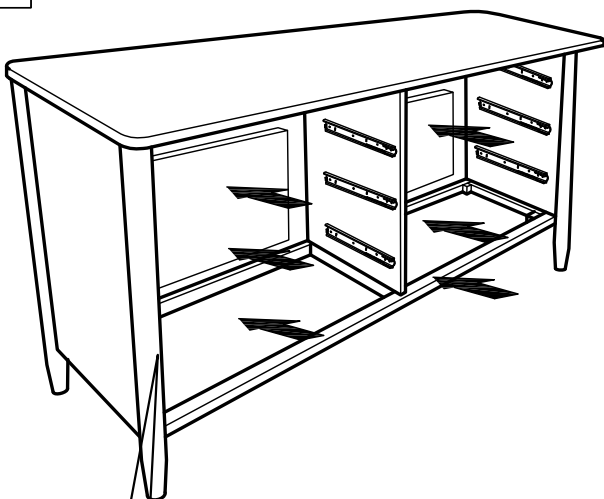

11



H(x2)

X6

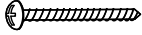
ANTI-TIPPING WITH METAL STRAPE (2 SET)

Metal Bracket  (2 X 2SET)	Cabinet Restraint Strap  (1 X 2SET)	Pan Head Screw (Long)  (1 X 2SET)	Pan Head Screw (Short)  (1 X 2SET)
--	--	---	---

1. Place the furniture into position so both mounting brackets are vertically in line.
2. Lace the end of the Cabinet Restraint Strap through the larger mounting position in each mounting bracket.
 Bring both ends together and slide the flat end through the locking end and draw it through until all slack is removed.
3. Confirm that the Cabinet Restraint Strap is securely laced and locked.

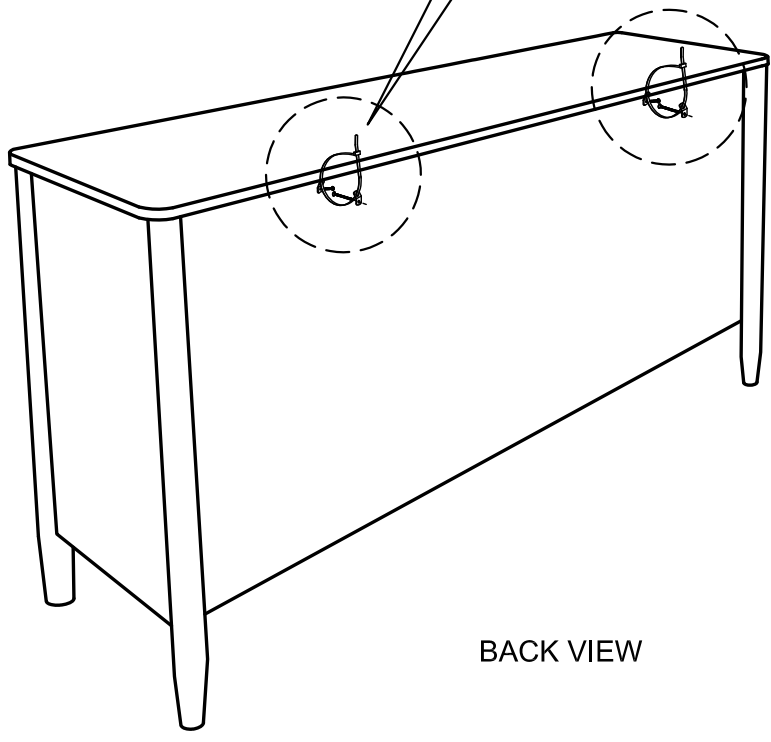
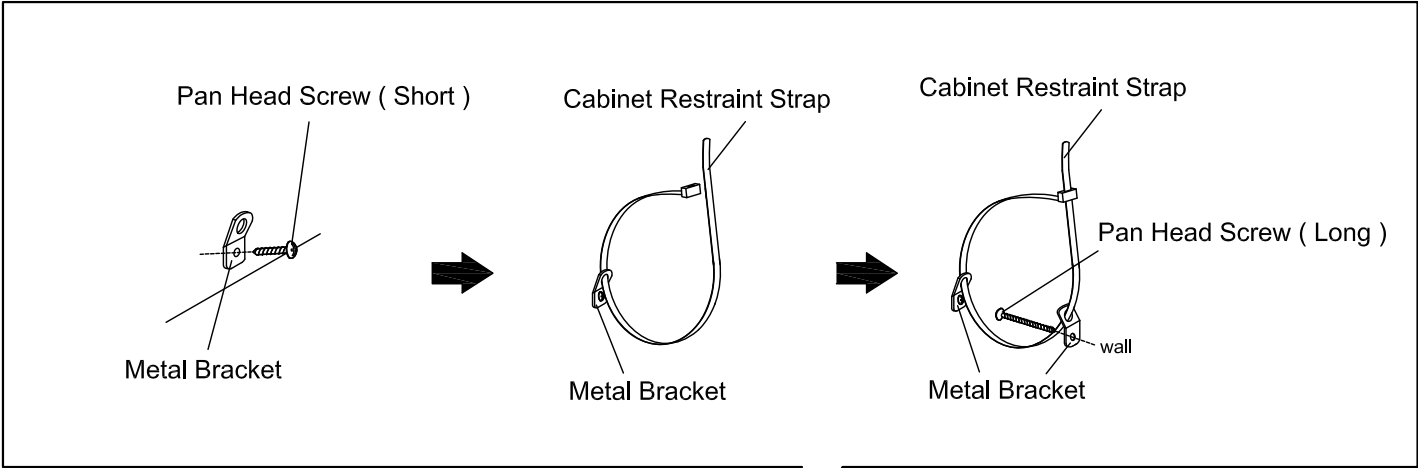



Parts and Damage Replacement Procedure

1. Please inspect your purchase immediately.
2. This procedure covers product purchased from an authorized Roundhill Reseller and was received in its originally sealed carton.
3. If you find a part missing or damaged, you have a 30-day window in which to order a replacement part from the date on your purchase receipt.
4. You have 3 ways to do this. You will need a copy of your purchase receipt.
 - a. By Fax: Fax the parts order form below and along with your receipt to 614-878-7918
 - b. By Email: Email the order form and along with your receipt to: parts@roundhillfurniture.com
 - c. By Mail: Fill out the parts order form below and along with a copy of your receipt send it to Roundhill furniture parts department 3640 Zane Trace Drive, Columbus OH 43228
5. Once this order is sent in, you will be notified if the part(s) you are requesting can or cannot be shipped within 7-10 business days.

**A COPY OF YOUR PURCHASE RECEIPT OR INVOICE MUST BE ATTACHED TO THIS ORDER FORM.
NO ORDERS WILL BE PROCESSED WITHOUT PROOF OF PURCHASE.**

NAME: _____
 ADDRESS: _____ (No Post Office Boxes)
 CITY: _____ STATE: _____ ZIP: _____
 PHONE: _____ FAX: _____
 EMAIL: _____

REASON FOR REPLACEMENT/PLEASE CHECK APPROPRIATE BOX.

- Damaged /scratched, cracked, broken, crushed, etc.
- Mechanical malfunction/ drawer glides, swivel mechanisms, lid stays, etc.
- Missing pieces
- Unfinished surface
- Wrong color
- Other

IF MORE THAN ONE MODEL NUMBER IS LISTED ABOVE, PLEASE SPECIFY THE EXACT MODEL NUMBER OF YOUR ITEM IN THE SPACE PROVIDED BELOW.

Model Number	Part Letter Code	Quantity