

Suggestion:

For a simpler and quicker assembly process,
we recommend that two people work together.

Due to the product's structure, the estimated assembly time is 60 minutes.

IMPORTANT:





1. Please read the instructions carefully before assembling the product.
2. Before starting the assembly process, check the package carefully to make sure all necessary boards and parts are included.
3. If there are any defective or missing parts after unpacking, please stop assembly and immediately contact us.
4. Before assembly, put all parts and boards in an open area. Ensure that you have the correct parts before screwing them in place.

Warning:

1. During assembly, keep all small objects out of the reach of children, as they may be fatal if swallowed or inhaled
2. Never allow children to climb or play around the product to protect children from injury caused by the tilting of the product.
3. To avoid the potential dangers of suffocation, please keep all parts and packaging away from children.

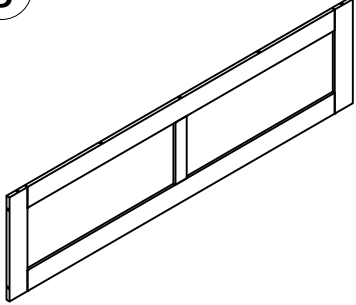
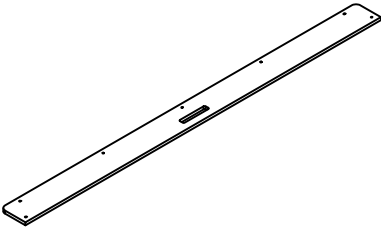

Parts Identification 1/3

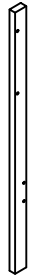
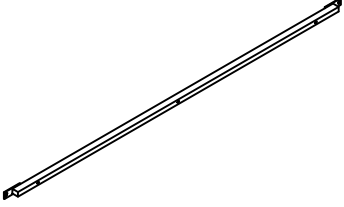
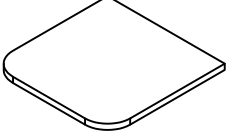
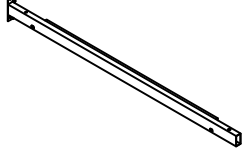
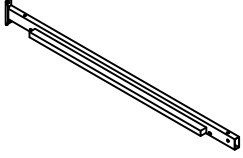
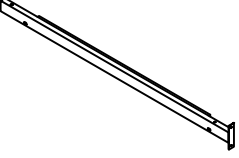
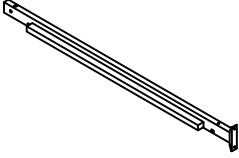
Not actual size

<p>①</p>  <p>Q'ty: 1</p>	<p>②</p>  <p>Q'ty: 1</p>	<p>③</p>  <p>Q'ty: 1</p>
<p>④</p>  <p>Q'ty: 1</p>	<p>⑤</p>  <p>Q'ty: 1</p>	<p>⑥</p>  <p>Q'ty: 1</p>
<p>⑦</p>  <p>Q'ty: 1</p>	<p>⑧</p>  <p>Q'ty: 2</p>	<p>⑨</p>  <p>Q'ty: 1</p>
<p>⑩</p>  <p>Q'ty: 1</p>	<p>⑪</p>  <p>Q'ty: 1</p>	<p>⑫</p>  <p>Q'ty: 1</p>

Parts Identification 2/3

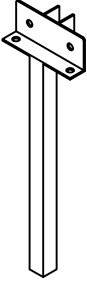
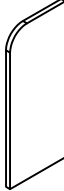
Not actual size

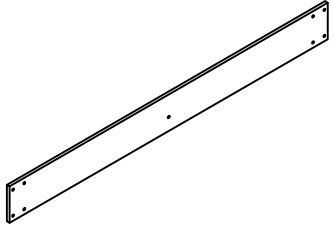
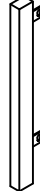
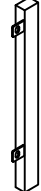
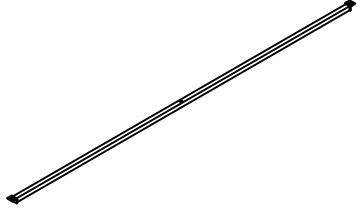
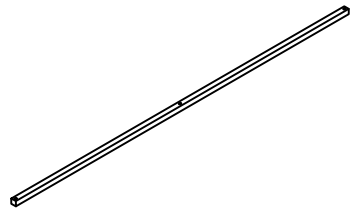
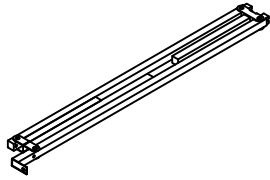
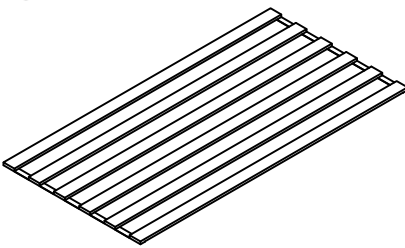
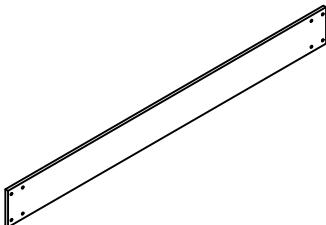
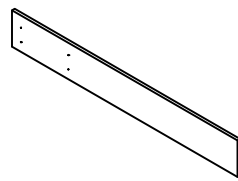
<p>13</p>  <p>Q'ty: 2</p>	<p>14</p>  <p>Q'ty: 1</p>	<p>15</p>  <p>Q'ty: 1</p>
<p>16</p>  <p>Q'ty: 1</p>	<p>17</p>  <p>Q'ty: 1</p>	<p>18</p>  <p>Q'ty: 1</p>
<p>19</p>  <p>Q'ty: 2</p>	<p>20</p>  <p>Q'ty: 1</p>	<p>21</p>  <p>Q'ty: 1</p>
<p>22</p>  <p>Q'ty: 2</p>	<p>23</p>  <p>Q'ty: 1</p>	<p>24</p>  <p>Q'ty: 1</p>

Parts Identification 3/3

Not actual size

25

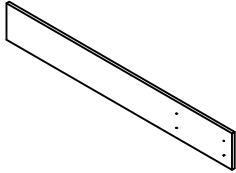





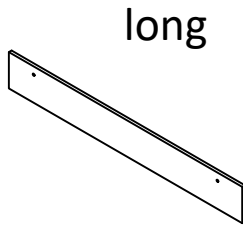

Q'ty: 1

26

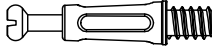

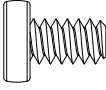
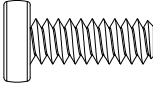
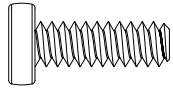
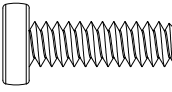
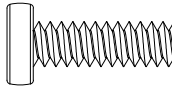
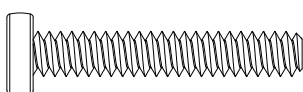
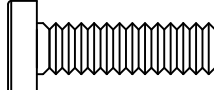
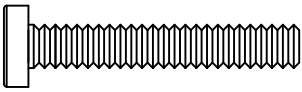
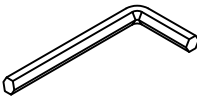
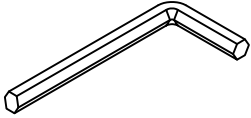
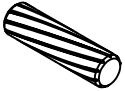
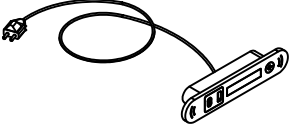
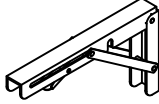
Q'ty: 2

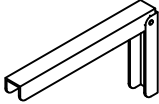
Hardware List

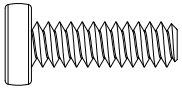
			
Ø1/4" x 11mm	Ø1/4" x 16mm	Ø1/4" x 11mm	Ø1/4" x 16mm
(A) x 11+1	(B) x 11+1	(C) x 15+1	(D) x 10+1
			
Ø1/4" x 20mm	Ø1/4" x 28mm	Ø1/4" x 35mm	Ø1/4" x 50mm
(E) x 16+1	(F) x 12+1	(G) x 3+1	(H) x 3+1
			
M8 x 28mm	M8 x 50mm	M4	M5
(I) x 2+1	(J) x 4+1	(K) x 1	(L) x 1
			
Ø6 x 30mm			Ø4 x 12mm
(M) x 2+1	(N) x 1	(O) x 2	(P) x 20+2
			
		Ø3 x 12mm	Ø1/4" x 32mm
(Q) x 1	(R) x 2	(S) x 2+1	(T) x 4+1

★ In many cases, we include additional hardware. So after following the assembly instructions, don't worry if there are still extra pieces left over—they're included as a "just in case" for your convenience.

★ NOTE: When assembling, please do not tighten the screws one by one completely first, until making sure that all the corresponding screws are placed in the right positions.

Self equipped tools



Cross Screwdriver
(Not included)



Slotted Screwdriver
(Not included)

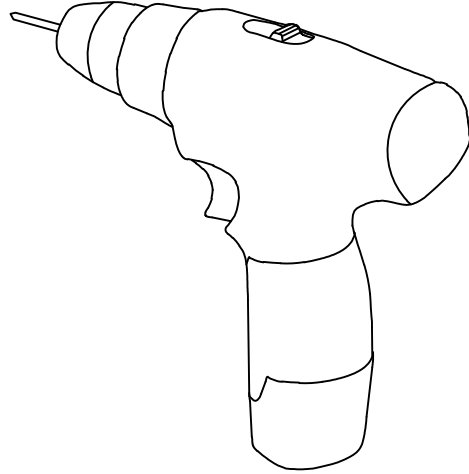

Electric Drill
(Not included)

Parts Identification

Not actual size

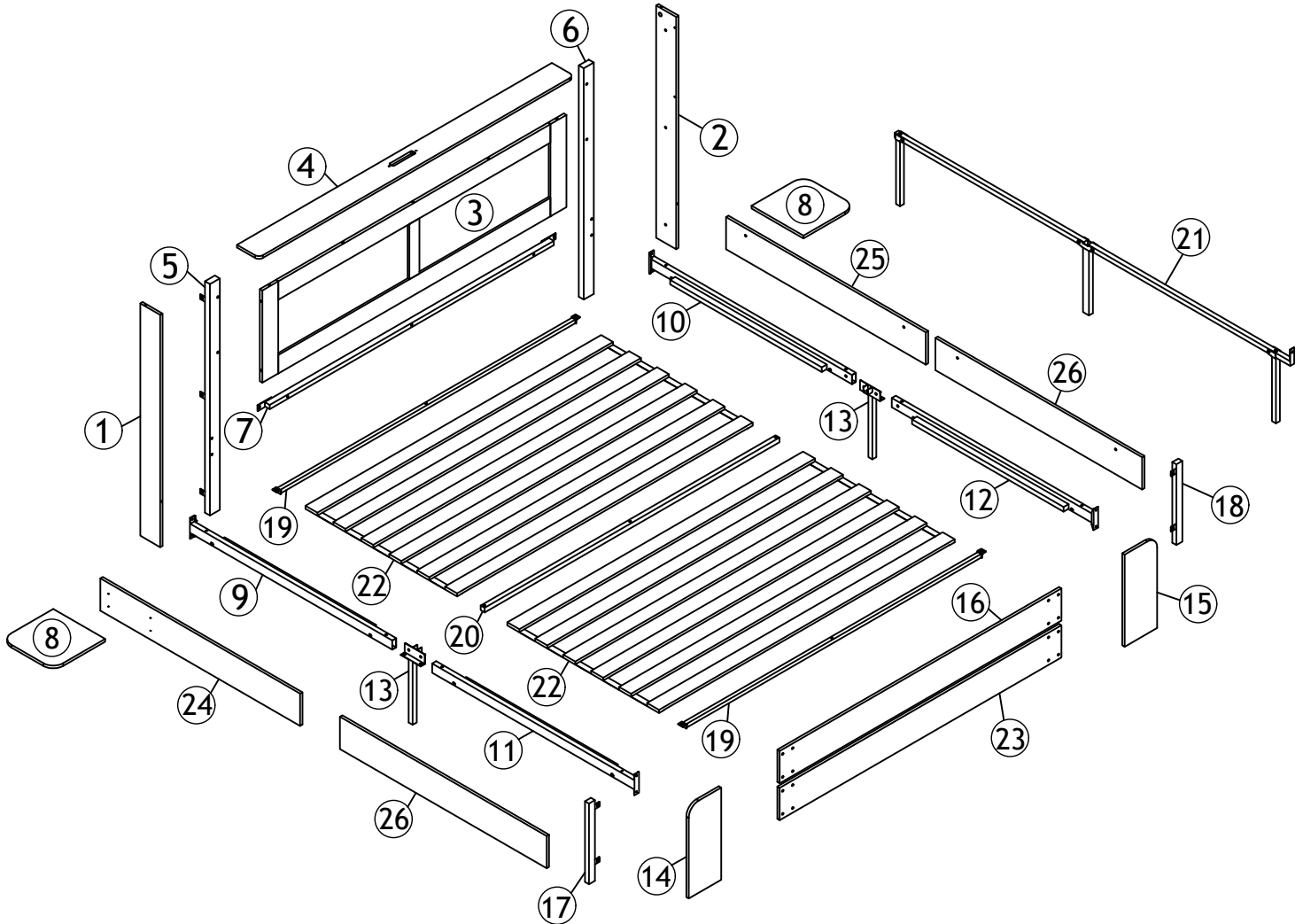





ATTENTION

When you begin each step, please check carefully whether you have taken the correct parts, so as not to use the wrong parts and cause the wrong assembly.

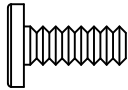
We recommend that you do not rush to tighten the screws. It is best to tighten the screws to two-thirds first, after all the steps are finished and the position is well adjusted, then tighten.

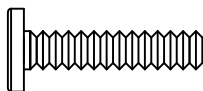
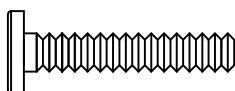
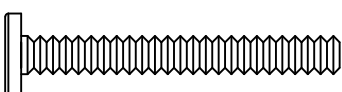
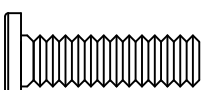
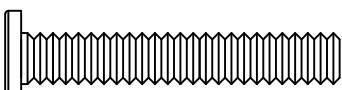
Screw Fitting 1:1 Diagram

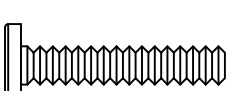
C		Ø1/4" x 11mm
D		Ø1/4" x 16mm
E		Ø1/4" x 20mm
F		Ø1/4" x 28mm
G		Ø1/4" x 35mm
H		Ø1/4" x 50mm
I		M8 x 28mm
J		M8 x 50mm
P		φ4 x 12mm
S		φ3 x 12mm
T		Ø1/4" x 32mm

STEP 1

 Please screws in this step need to be tightened

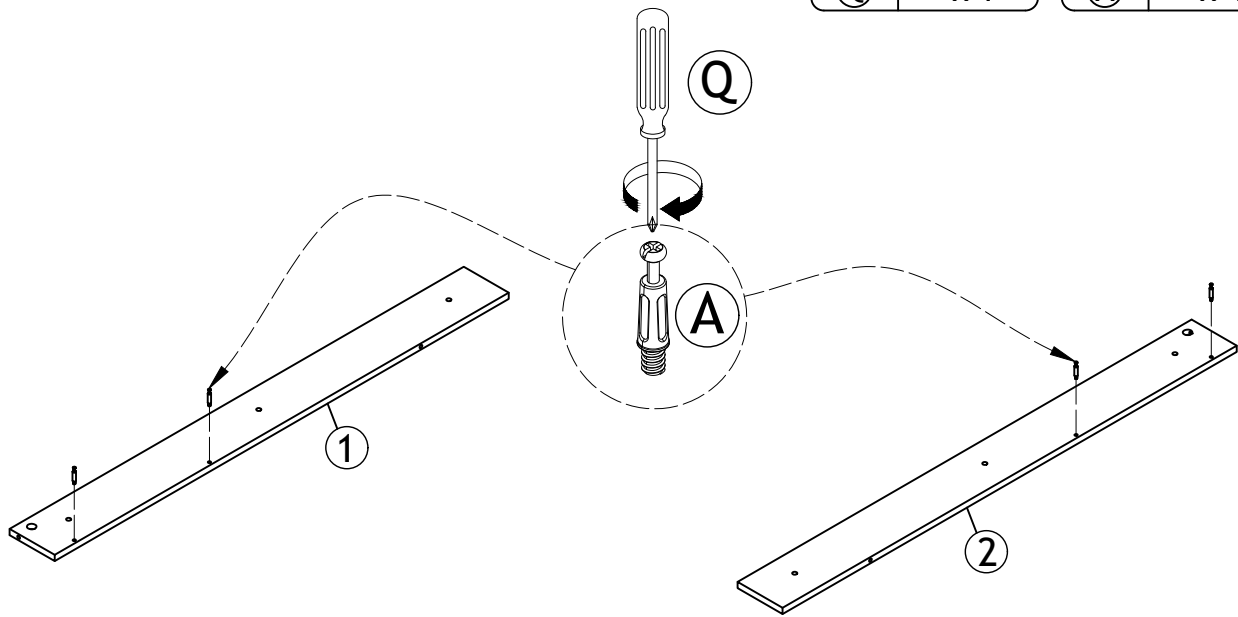
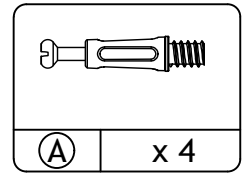
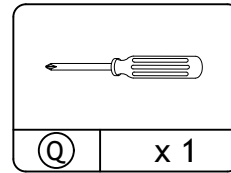

STEP 2

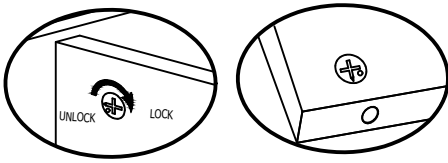

Proper orientation of CAM LOCK

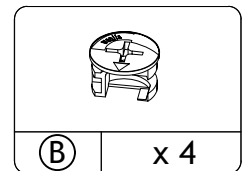
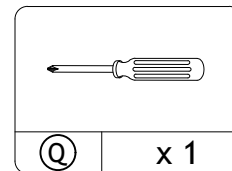

 Please screws in this step need to be tightened

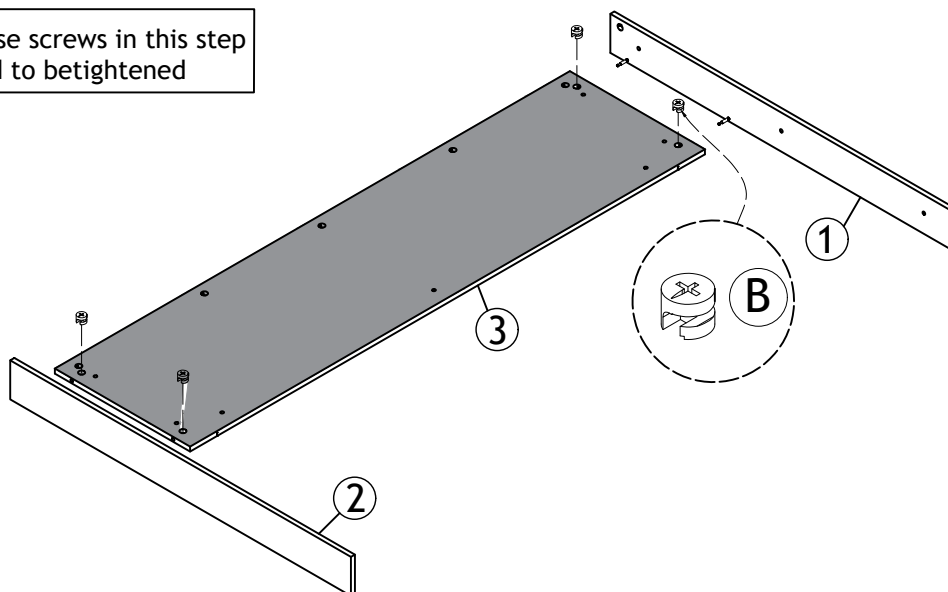

STEP 3

 Please screws in this step need to be tightened

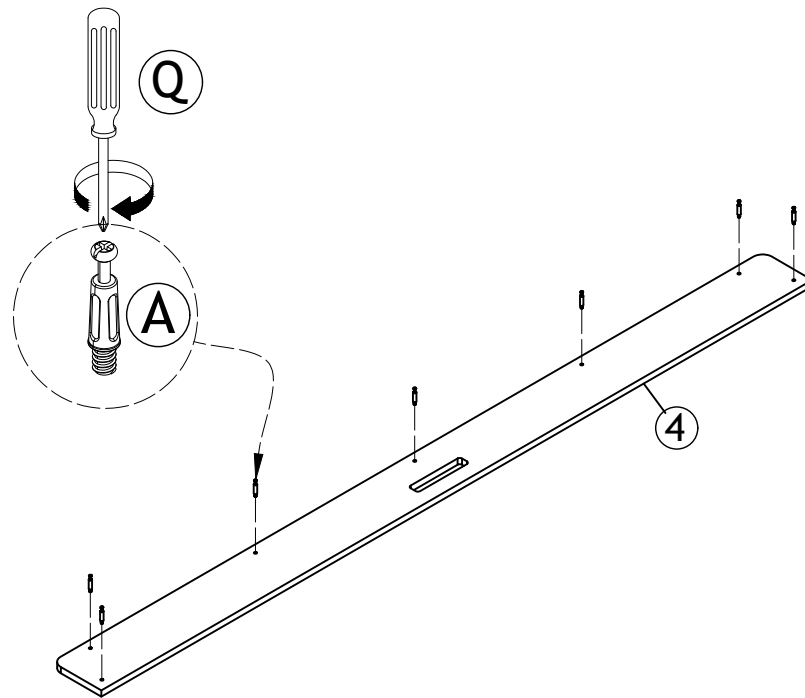
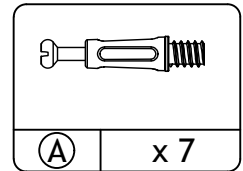
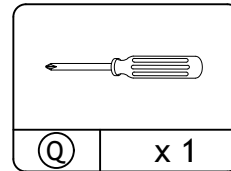

STEP 4

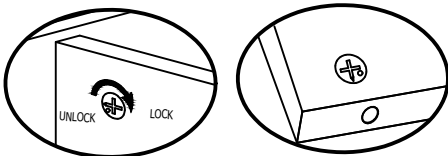

Proper orientation of CAM LOCK

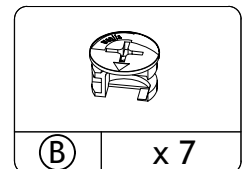
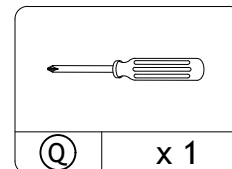

 Please screws in this step need to be tightened

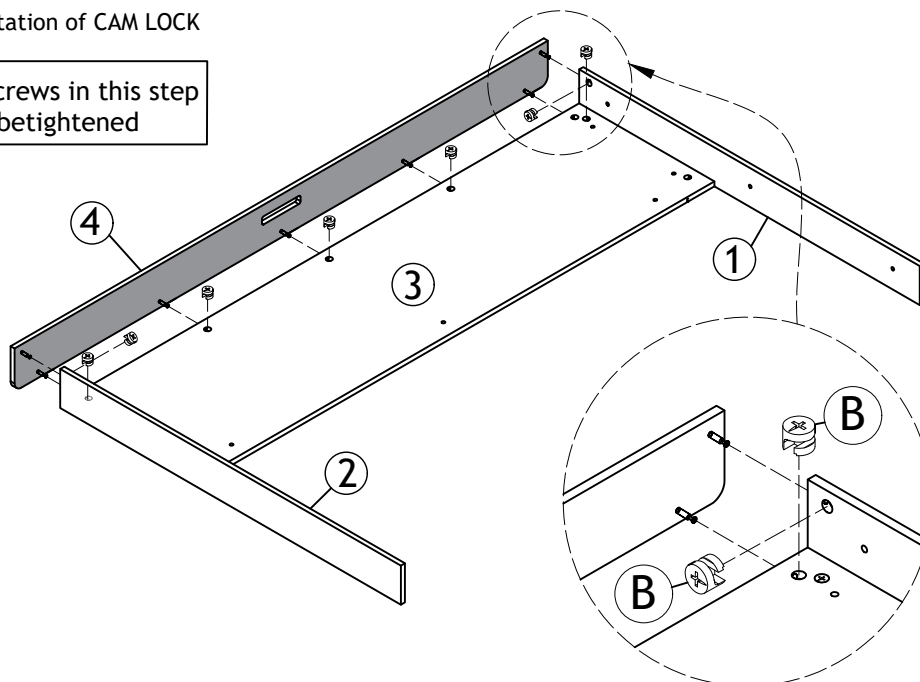

STEP 5

⚠ Please tighten the bolts to 80% first, and tighten all bolts 100% after all parts are assembled.

Ø1/4" x 16mm
 (D) x 2

M4
 (K) x 1

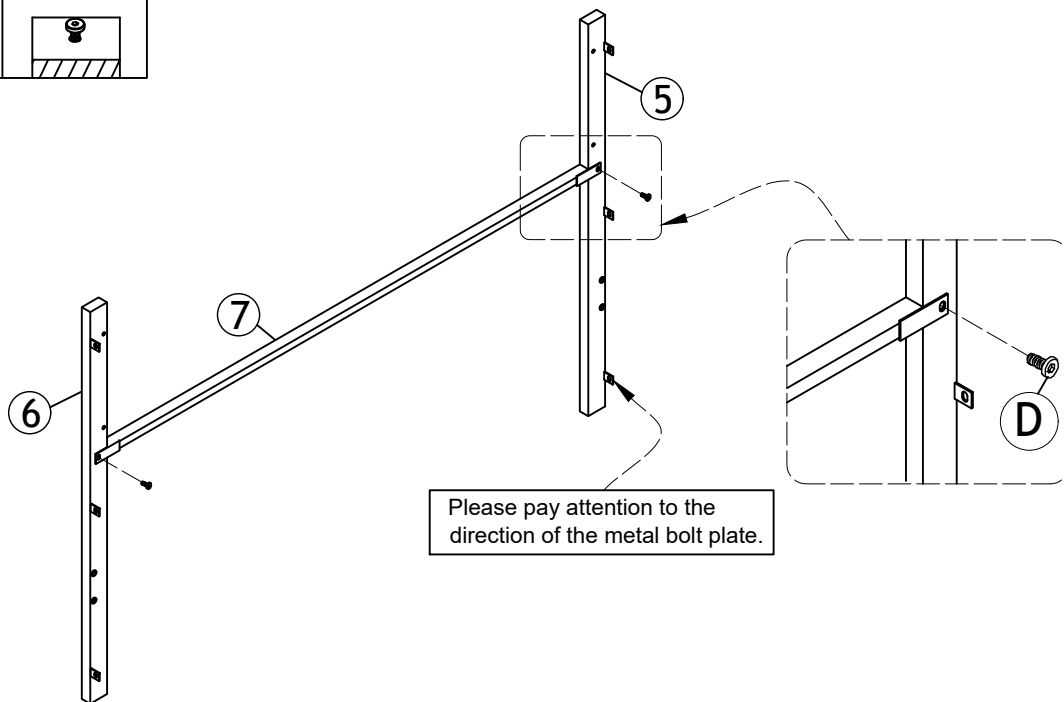

STEP 6

⚠ Please tighten the bolts to 80% first, and tighten all bolts 100% after all parts are assembled.

Ø1/4" x 32mm
 (T) x 4

Ø1/4" x 35mm
 (G) x 3

Ø1/4" x 11mm
 (C) x 6

M4
 (K) x 1

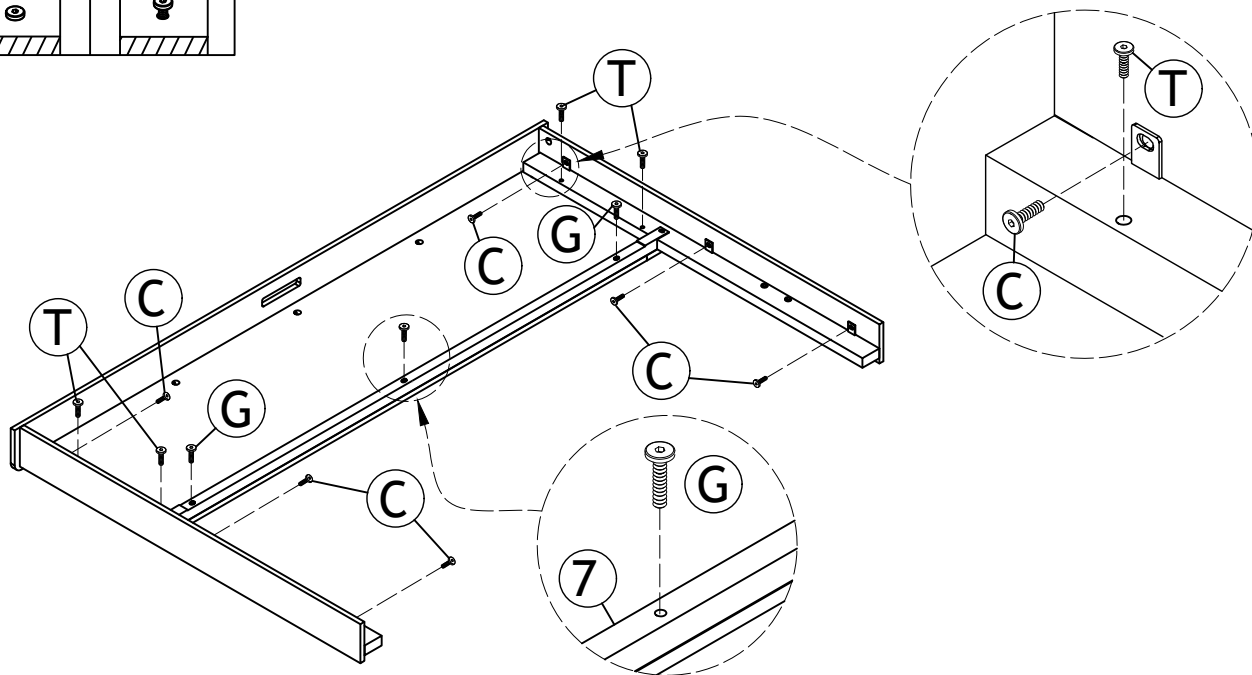

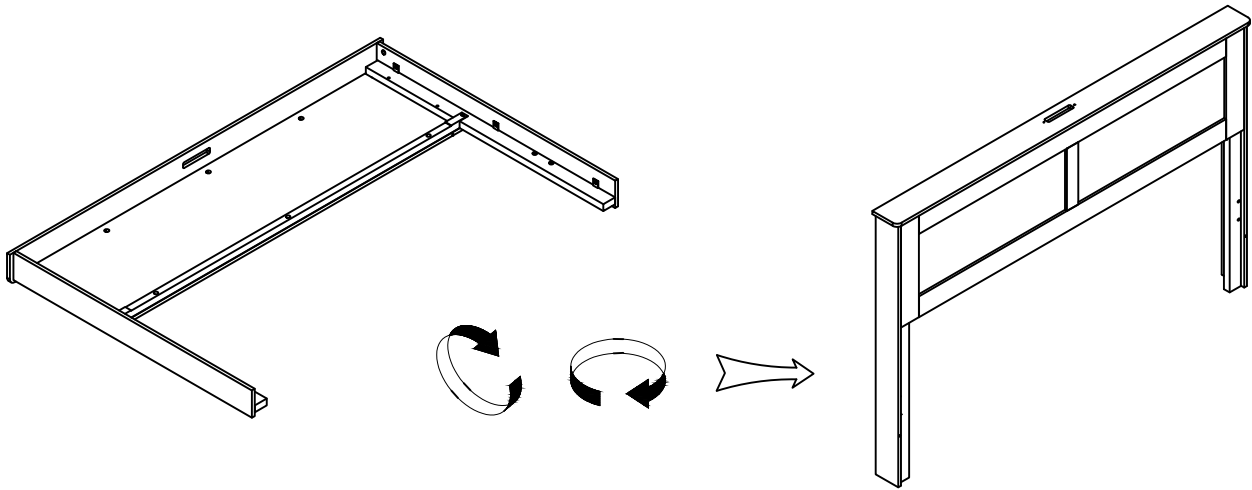

STEP 7



STEP 8

 Please tighten the bolts to 80% first, and tighten all bolts 100% after all parts are assembled.

	
-------------------------------------------------------------------------------------	-------------------------------------------------------------------------------------

Ø1/4" x 28mm
(F) x 4

M4
(K) x 1

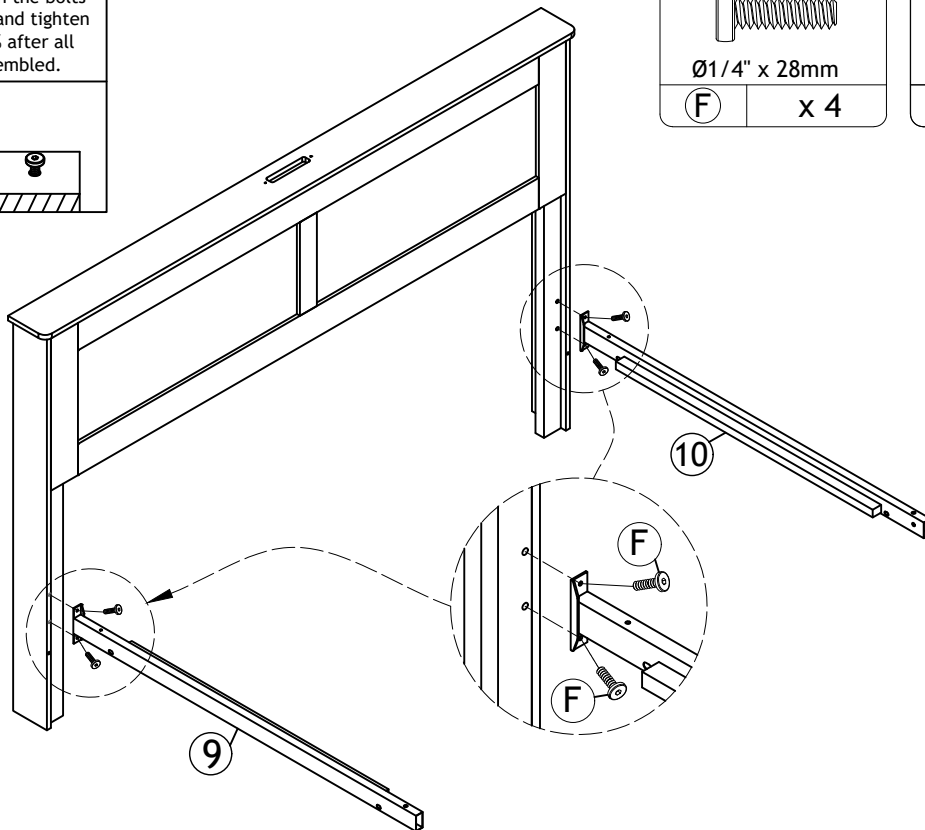

STEP 9

⚠ Please tighten the bolts to 80% first, and tighten all bolts 100% after all parts are assembled.

Ø1/4" x 11mm
 (C) x 4

M4
 (K) x 1

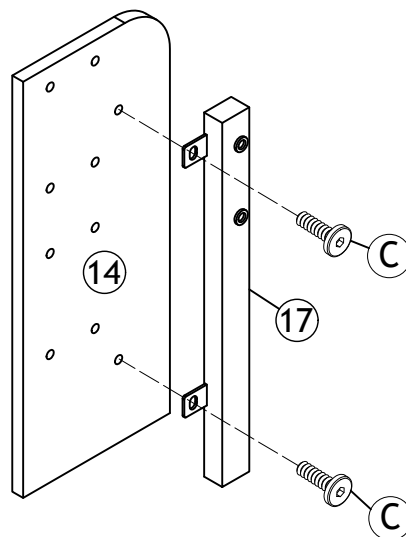
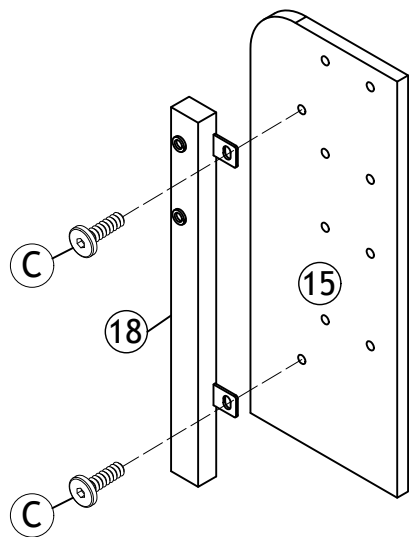

STEP 10

⚠ Please tighten the bolts to 80% first, and tighten all bolts 100% after all parts are assembled.

Ø1/4" x 20mm
 (E) x 16

M4
 (K) x 1

The side with a longer hole spacing is facing upwards

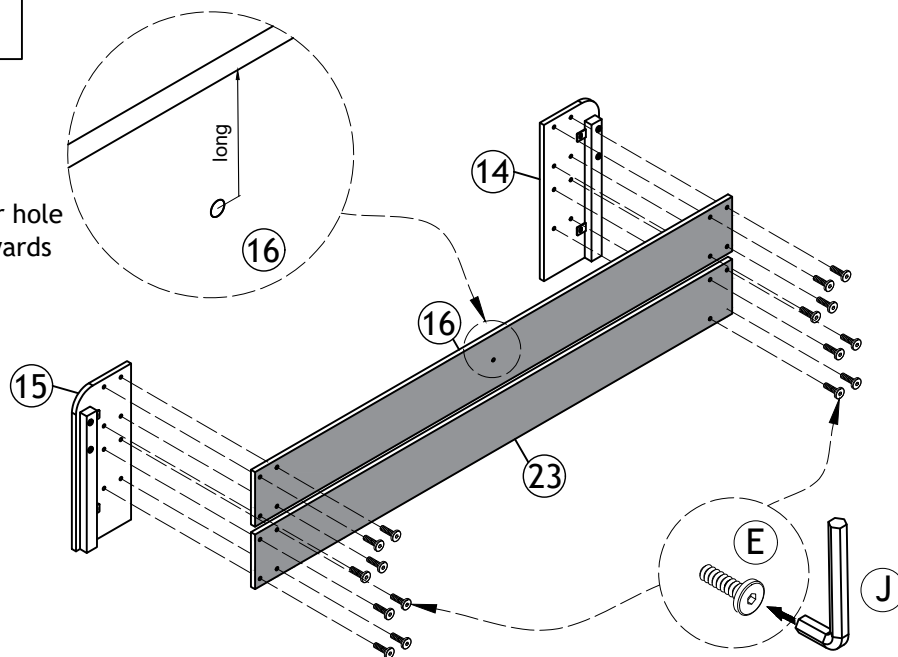

STEP 11

⚠ Please tighten the bolts to 80% first, and tighten all bolts 100% after all parts are assembled.

Ø1/4" x 16mm
 (D) x 4

M4
 (K) x 1

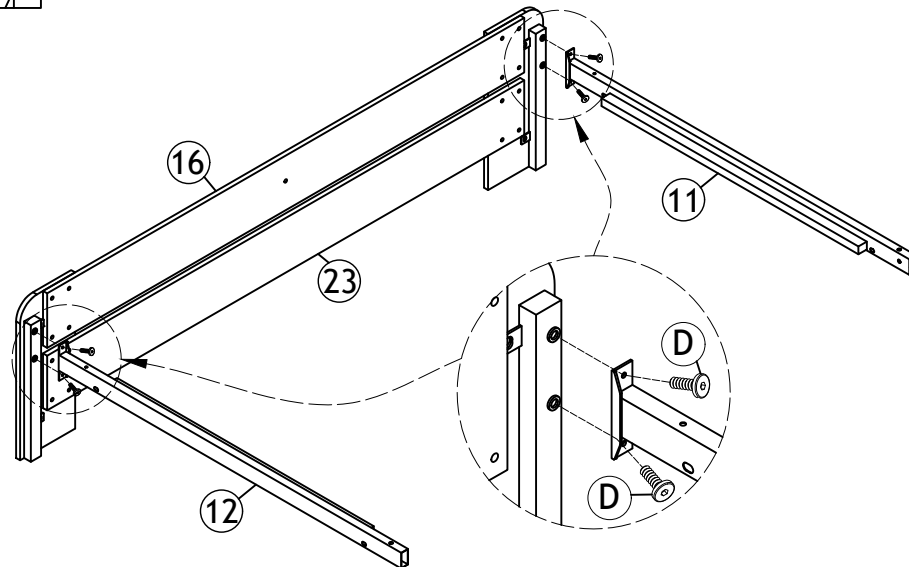

STEP 12

⚠ Please tighten the bolts to 80% first, and tighten all bolts 100% after all parts are assembled.

Ø1/4" x 16mm
 (D) x 4

M8 x 50mm
 (J) x 4

M4
 (K) x 1

M5
 (L) x 1

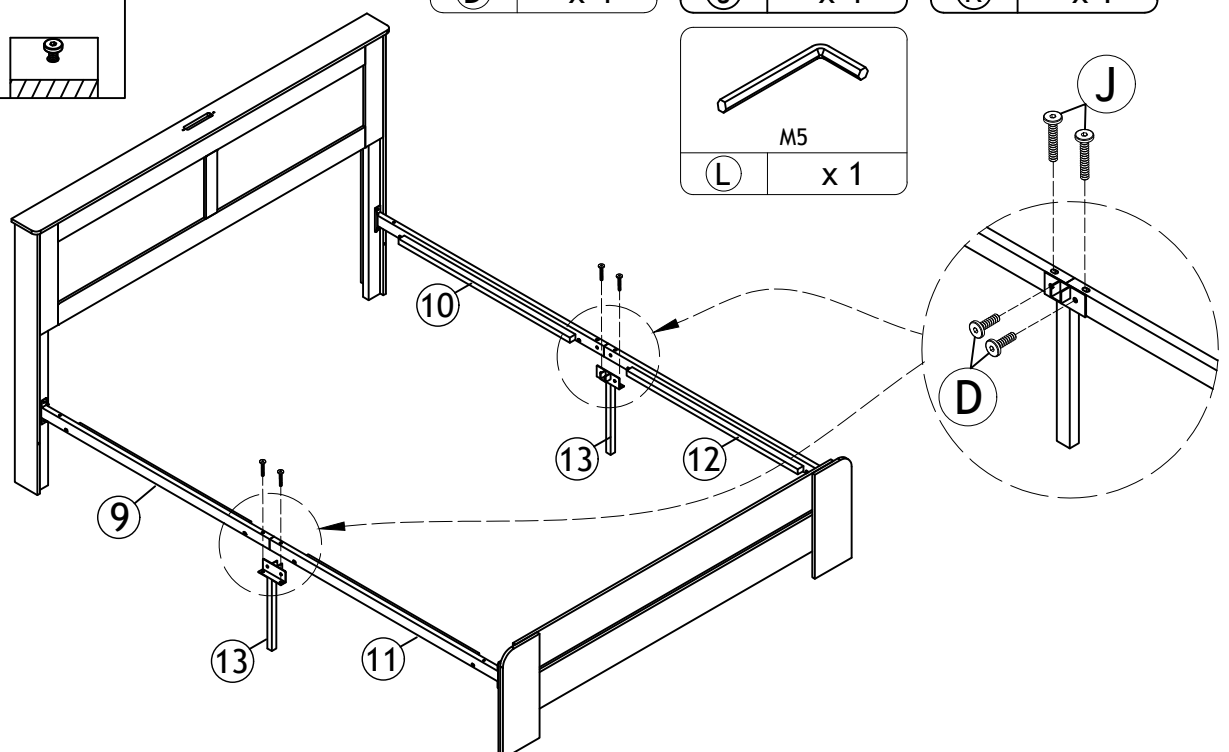

STEP 13

 Please tighten the bolts to 80% first, and tighten all bolts 100% after all parts are assembled.

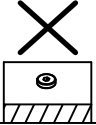
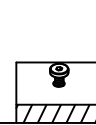
	
-----------------------------------------------------------------------------------	-----------------------------------------------------------------------------------

Ø1/4" x 11mm
(C) x 4

M4
(K) x 1

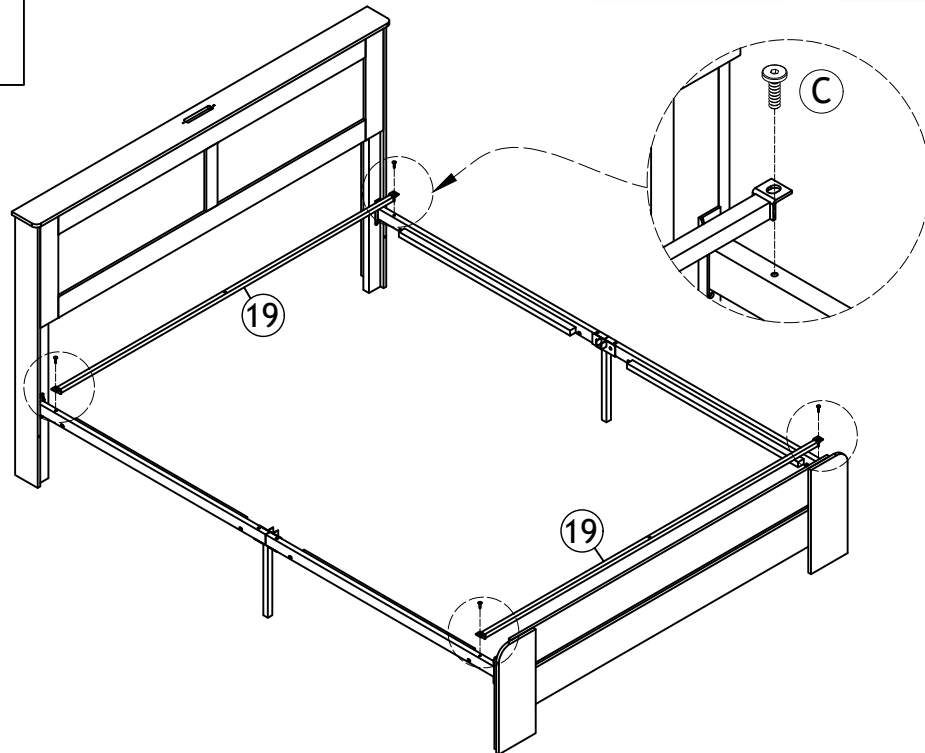

STEP 14

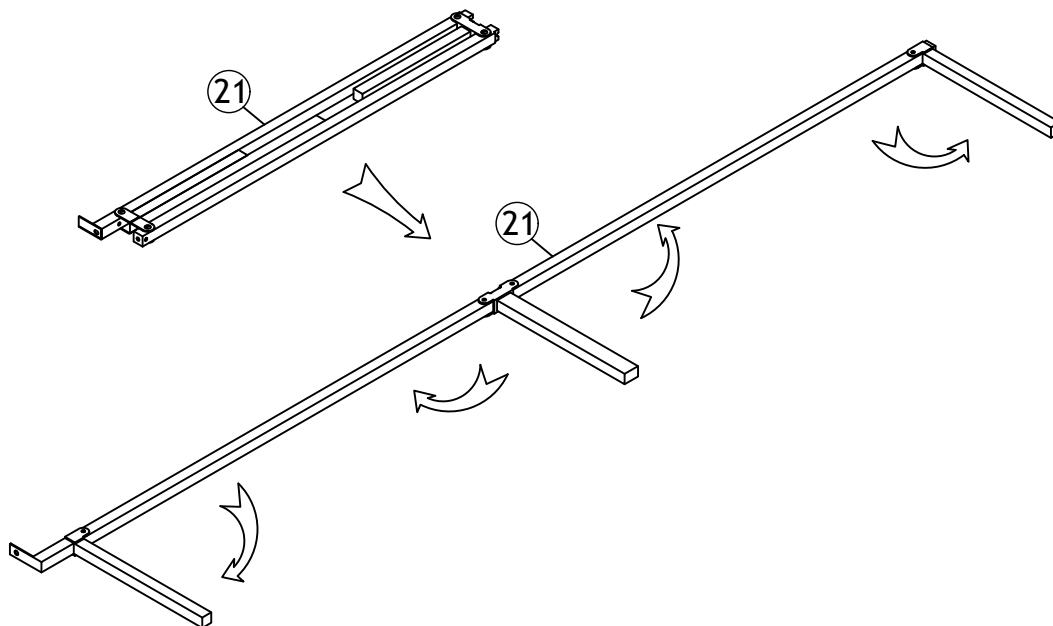

Expand the folded portion

STEP 15

⚠ Please tighten the bolts to 80% first, and tighten all bolts 100% after all parts are assembled.

Ø1/4" x 50mm
 (H) x 2

M4
 (K) x 1

Ø1/4" x 11mm
 (C) x 1

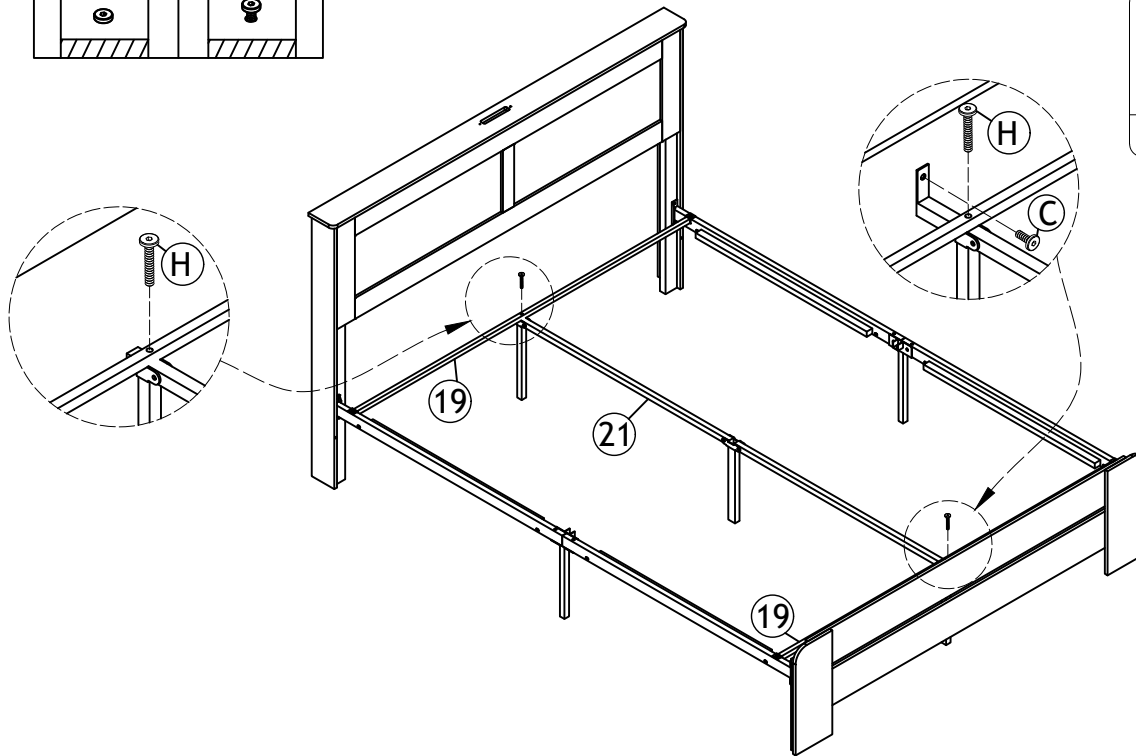

STEP 16

⚠ Please tighten the bolts to 80% first, and tighten all bolts 100% after all parts are assembled.

M8 x 28mm
 (I) x 2

Ø1/4" x 50mm
 (H) x 1

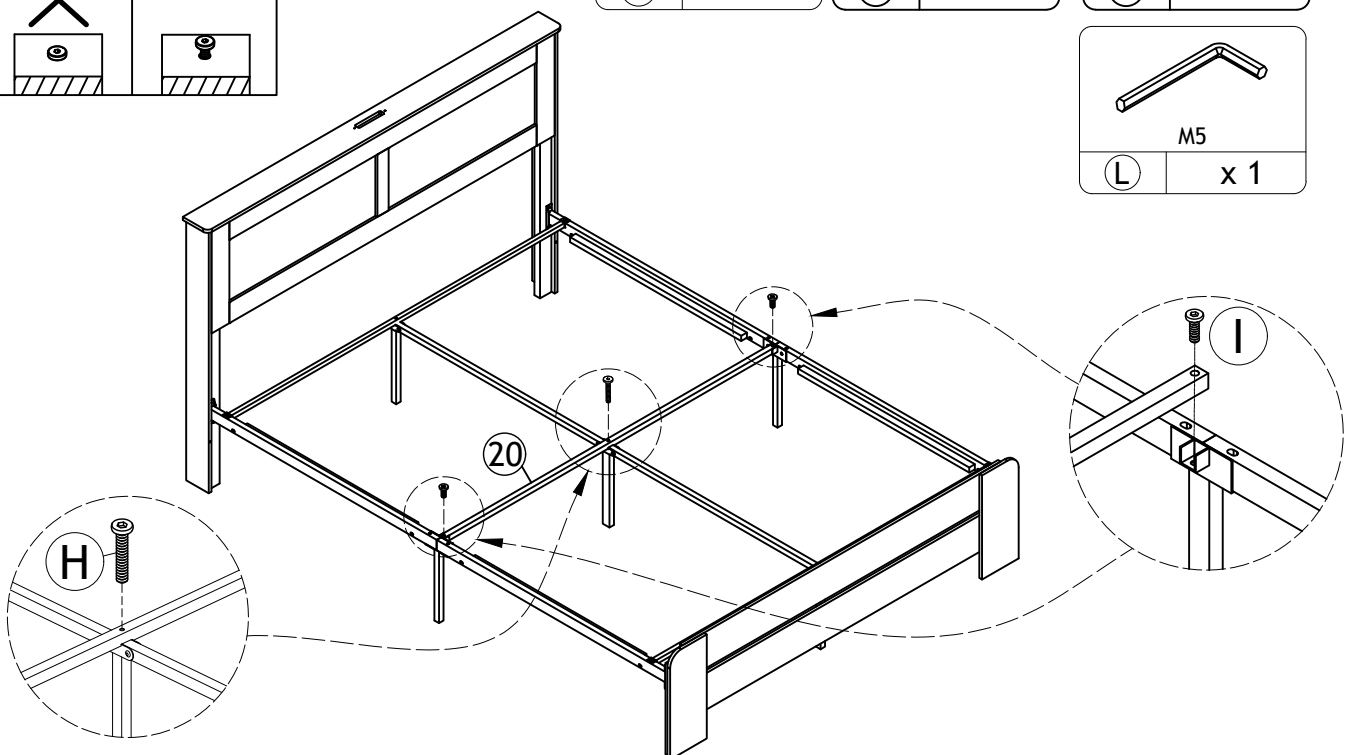

M4
 (K) x 1

M5
 (L) x 1



STEP 17

 Please tighten the bolts to 80% first, and tighten all bolts 100% after all parts are assembled.

	
-----------------------------------------------------------------------------------	-----------------------------------------------------------------------------------



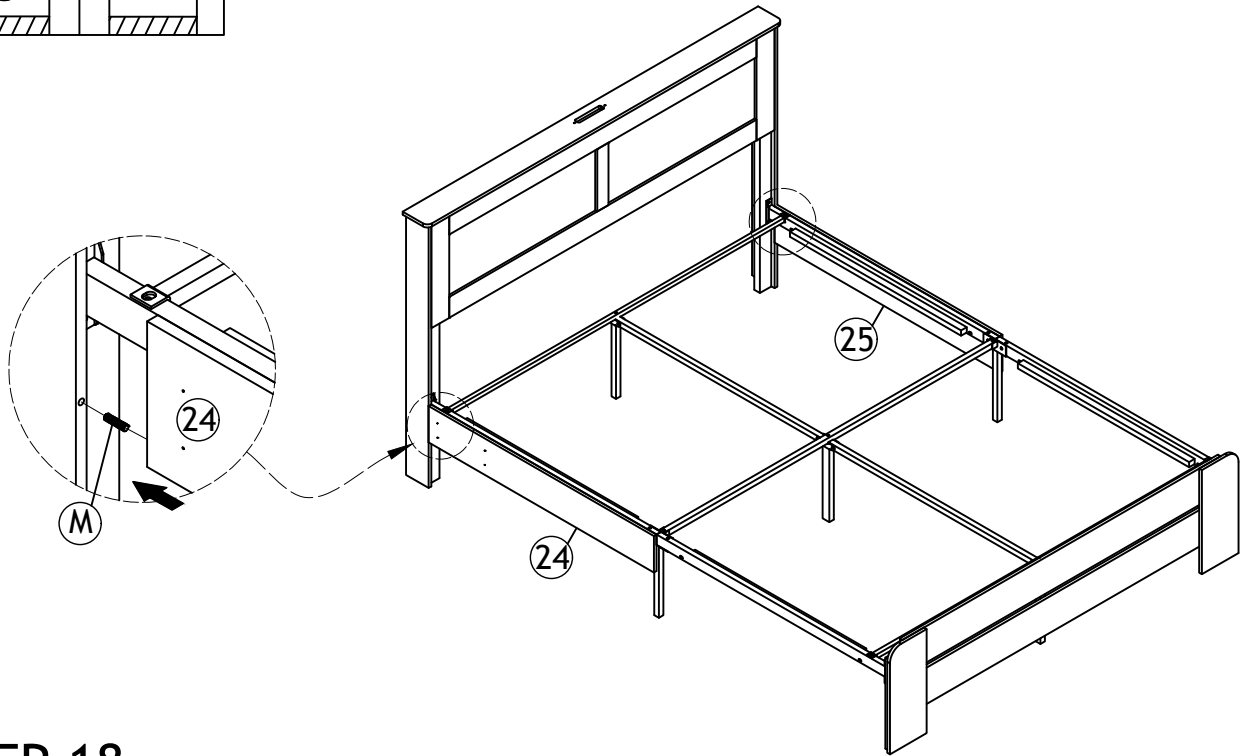

Ø6 x 30mm

(M)	x 2
-----	-----



STEP 18

 Please tighten the bolts to 80% first, and tighten all bolts 100% after all parts are assembled.

	
-------------------------------------------------------------------------------------	-------------------------------------------------------------------------------------



Ø1/4" x 28mm

(F)	x 8
-----	-----



M4

(K)	x 1
-----	-----

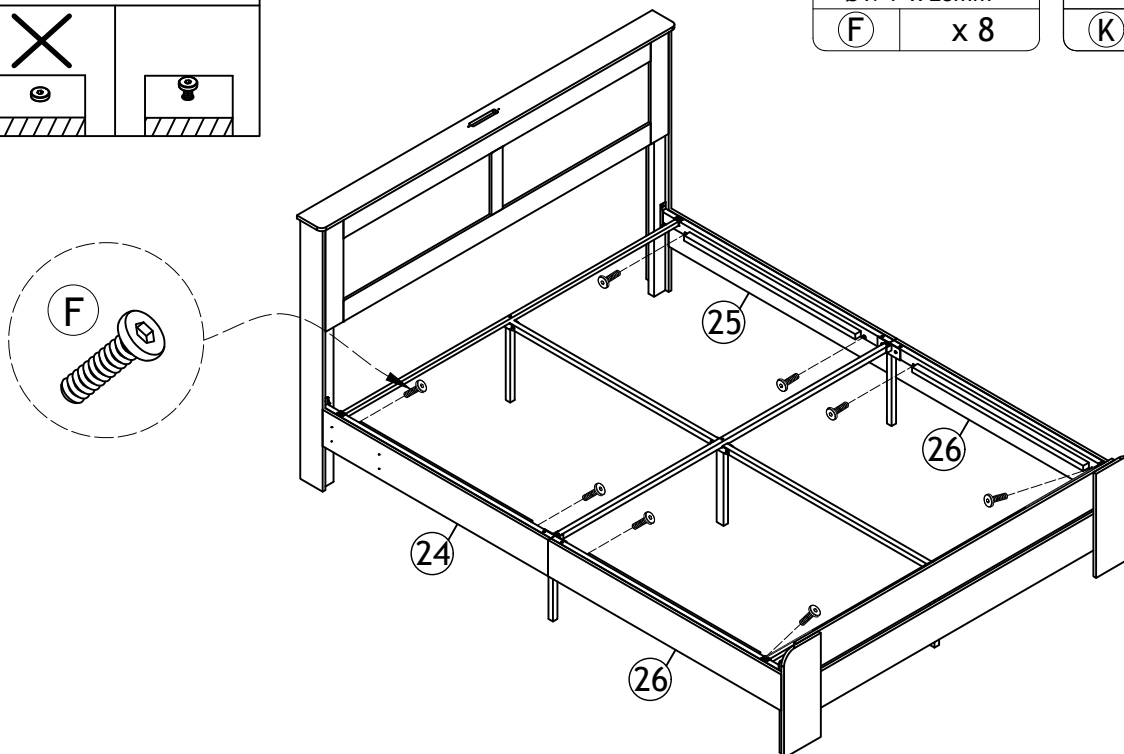

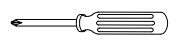

STEP 19

 Please screws in this step need to be tightened

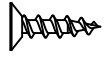
Q x 1

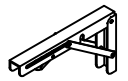
Ø4 x 12mm
P x 12



O x 2

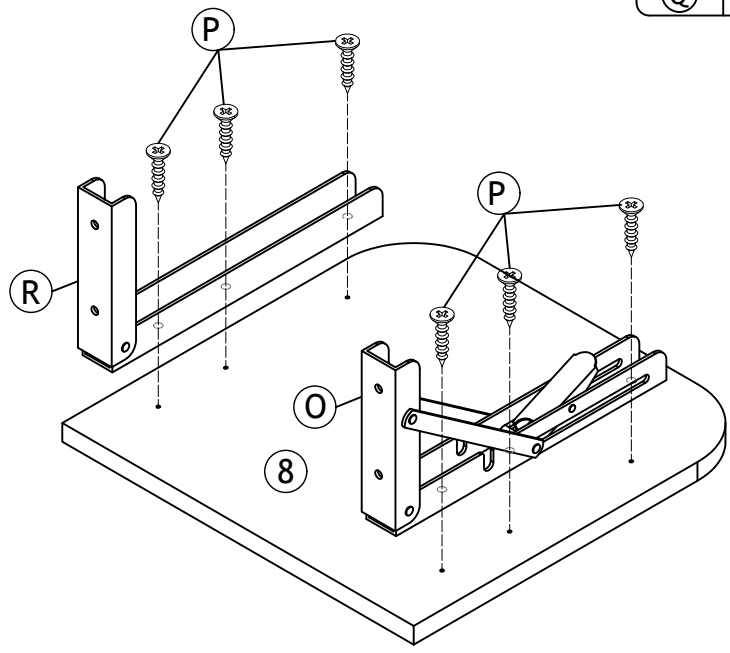

R x 2



X 2

STEP 20

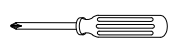
 Please screws in this step need to be tightened

Q x 1

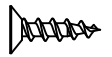

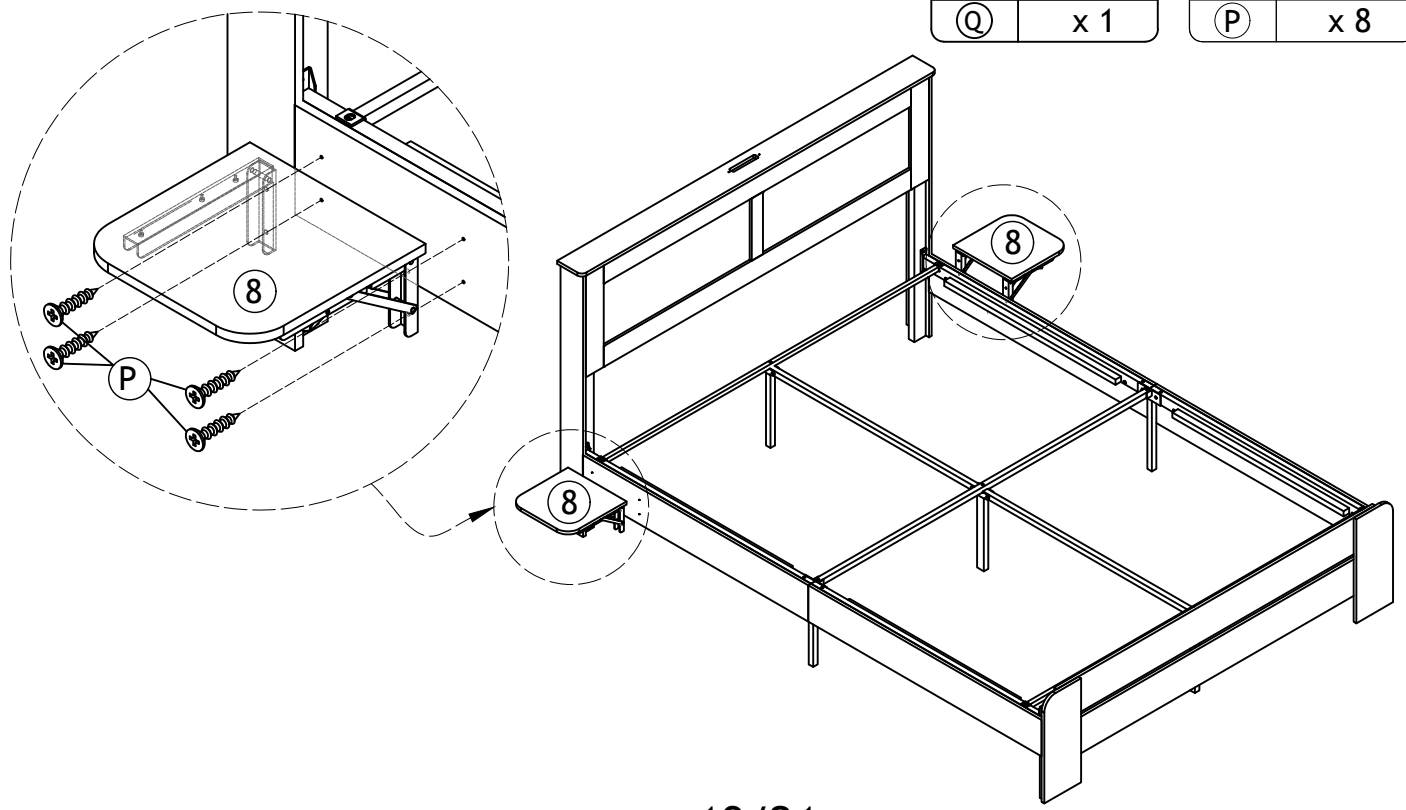
Ø4 x 12mm
P x 8

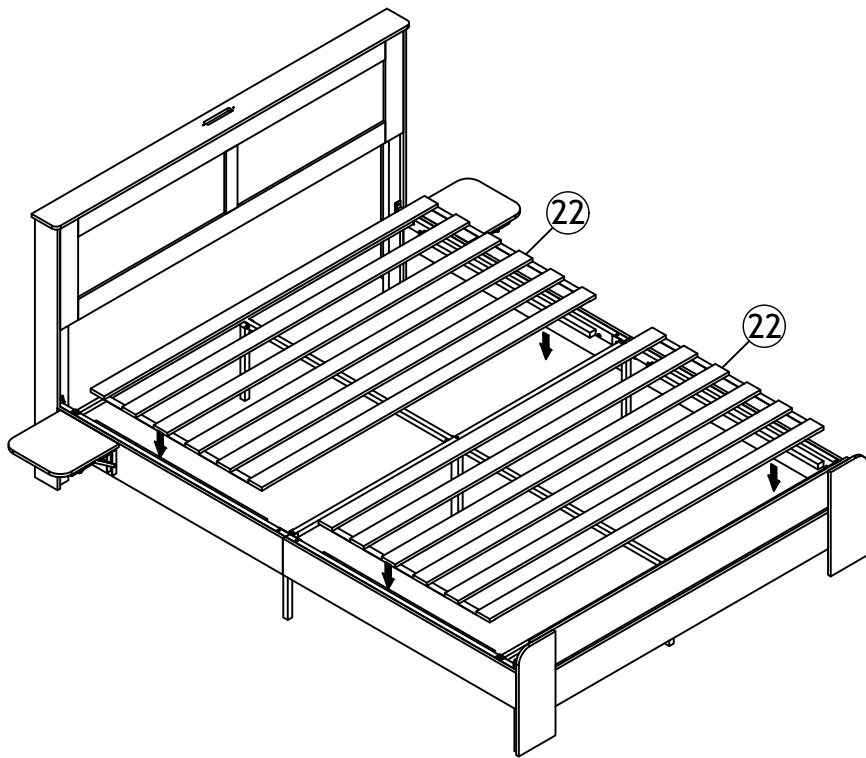

STEP 21



STEP 22

 Please ensure all screws on the bed frame are securely tightened.

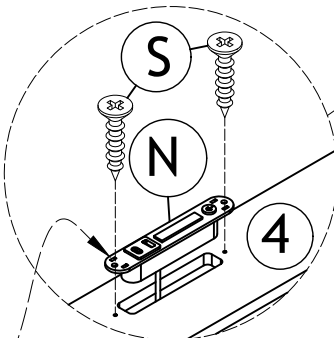
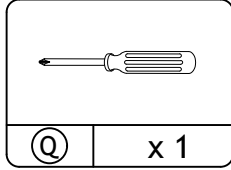
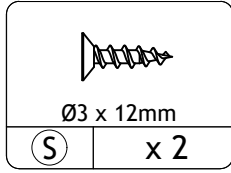
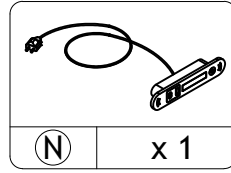

Please remove the cover of component N first.

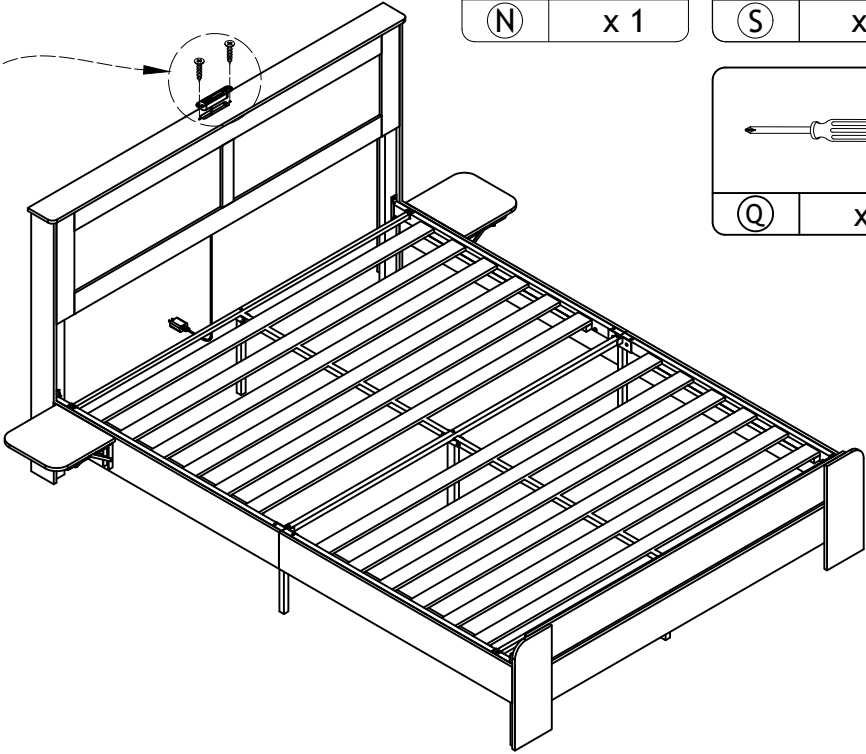
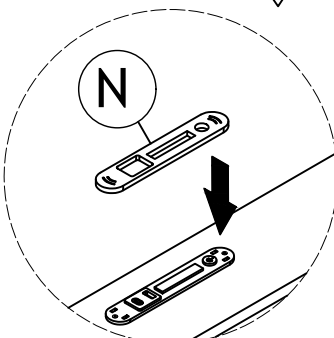

STEP 23

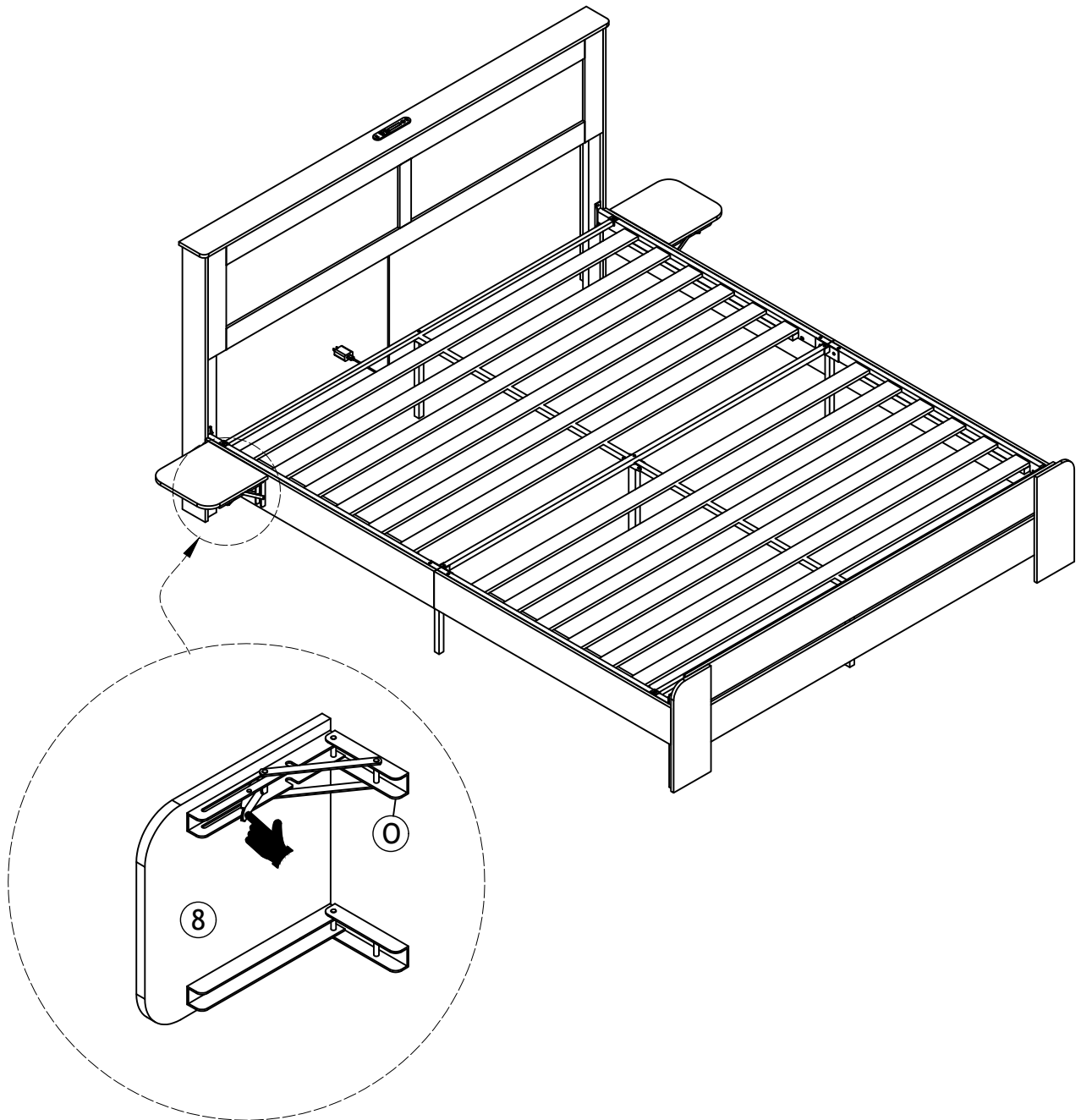

Pressing the button on component O can fold panel 8.

Congratulation:

Congratulations to you on completing the assembly of the product through your own efforts, you have done a great job.

The assembly of this product may have been difficult, but you still had the patience and perseverance to get it done.

1. The product is designed for indoor use only and must be assembled and used according to the provided manual. Modifying or altering the product from its original design may result in personal injury or damage to the product.

Product Maintenance:

1. Please place this item on the level solid ground.
2. Avoid long-term exposure to humid environments to prevent mildew.
3. Keep the product away from high temperature environments or fire sources.
4. If accidentally spill water or another liquid on the surface, immediately wipe with a dry towel.
5. Regularly inspect the tightness of screws while using the product. If necessary, re-tighten to ensure structural stability.