

VIVOHOME

**THANK  
YOU!**

**NOTE:**

To continuously improve its products, VIVOHOME reserves the right to modify this information without prior notification.

For any questions regarding assembly, please watch the video on the product page or contact our customer service. Our customer service will gladly assist you with any additional questions, comments, or concerns.

Thank you for using VIVOHOME products in your home!

Thank You for Purchasing from

VIVOHOME

Made in China

VIVOHOME

**HOW-TO**

USER MANUAL

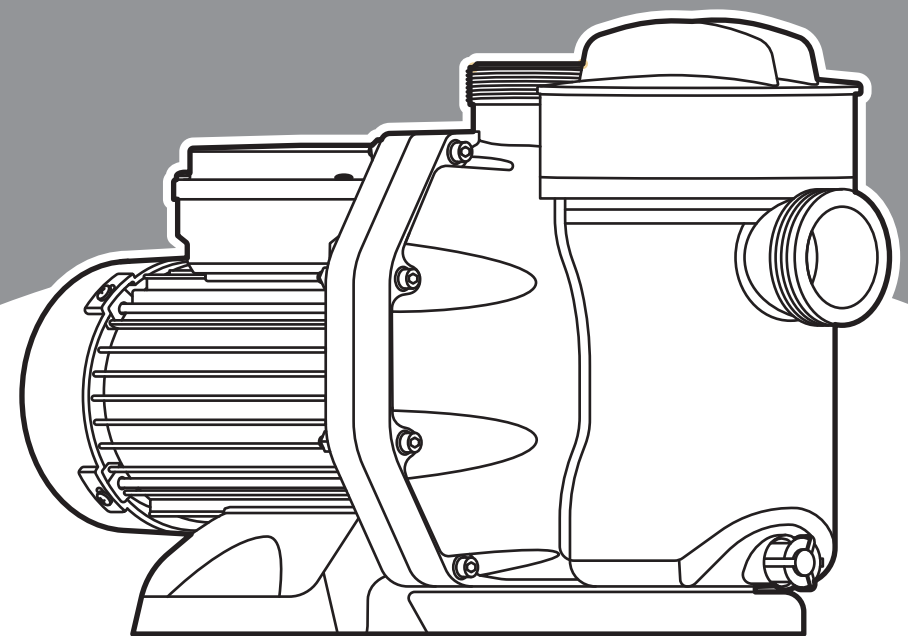

**2.5HP Pool Pump with Timer**

Assembly is EASY!

**WE WANT  
YOU TO  
ENJOY LIFE  
AT HOME**

GO TO THE PRODUCT LISTING PAGE  
FOR AN INSTRUCTIONAL VIDEO!

## CONTENTS

Notes .....	1
Packing List .....	5
Wire Installation .....	7
Pipe Installation .....	9
Pump Installation.....	10
Electrical Installation .....	10
Preparation Before Starting the Pump .....	11
Timer Setting .....	11
Starting the Pump .....	13
Troubleshooting .....	13
Storage .....	17
Technical Data of Pump .....	17
Warranty .....	18



1. The pump should be fixed on a level concrete slab. Vibration will reduce the service life of the pump.

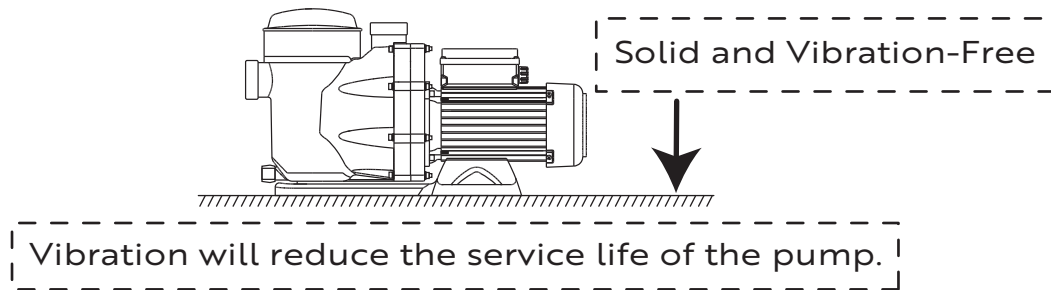

2. Fill the pump with water before starting. Do not run pump dry. Water acts as a coolant and lubricant for the mechanical shaft seal. Running pump dry may damage seals, causing leakage, flooding, and void warranty.

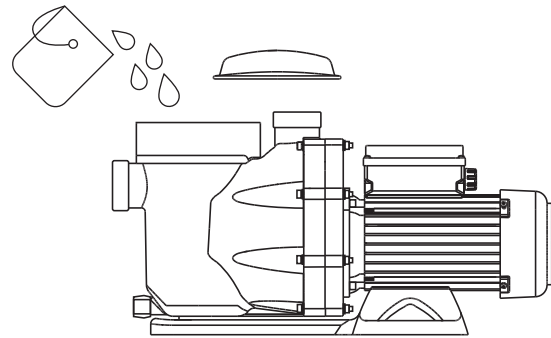

3. Connect only to a branch circuit protected by a ground-fault circuit interrupter (GFCI).

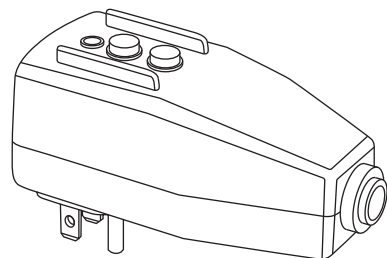

GFCI is not included in the package, please purchase it yourself.

4. As the horizontal pipeline increases, the self suction height will decrease.

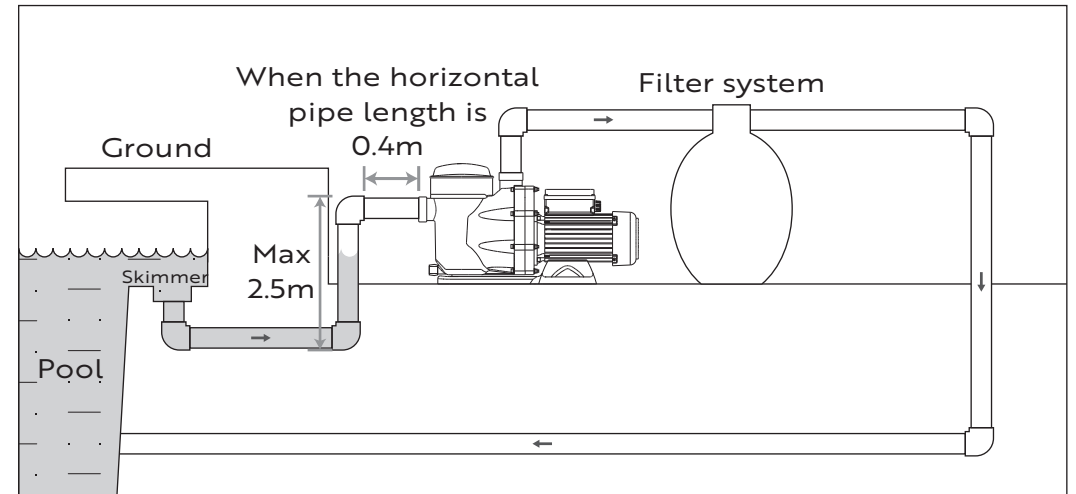

Note: The dry pipe before the pump inlet must not exceed a total length of 2.9 meters.

5. Independently of the height of the pump above the water and the capacity of the chosen model, priming will take several minutes. Priming time will depend on vertical length of suction lift and horizontal length of suction pipe. If pump does not prime within five minutes, stop motor and determine cause. See Troubleshooting Guide.

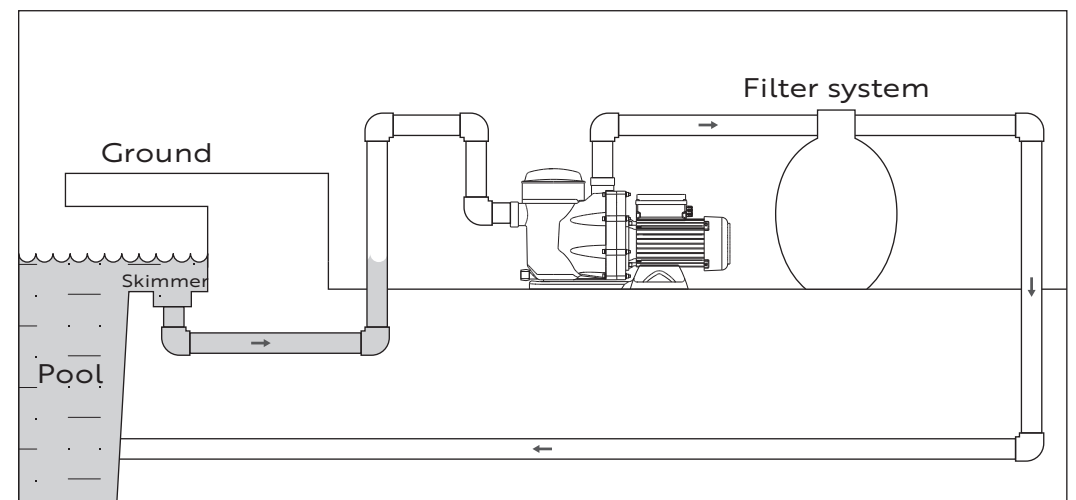

Note: If the pipe leading to the pump is too long, it may struggle to draw water.

6. In-Ground Pool: Installing a non-return device will lead to immediate priming.

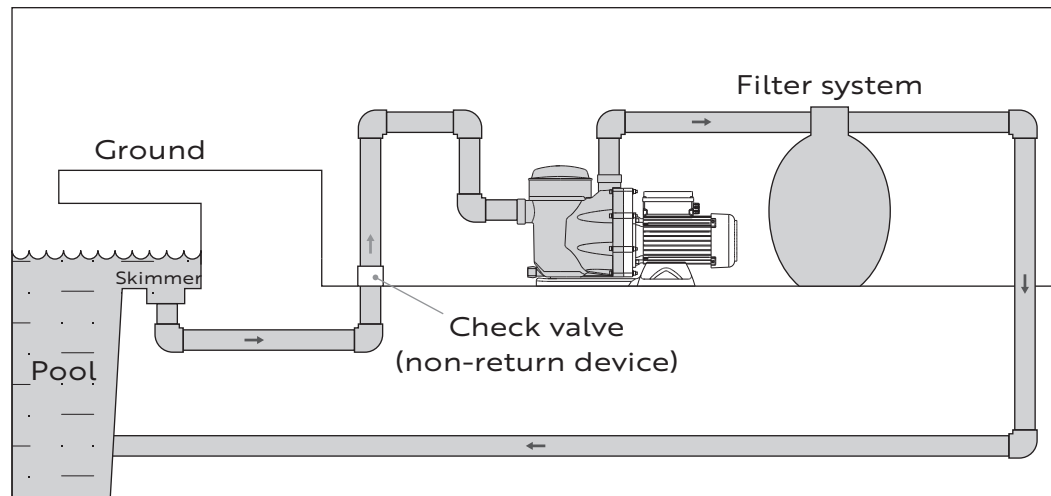
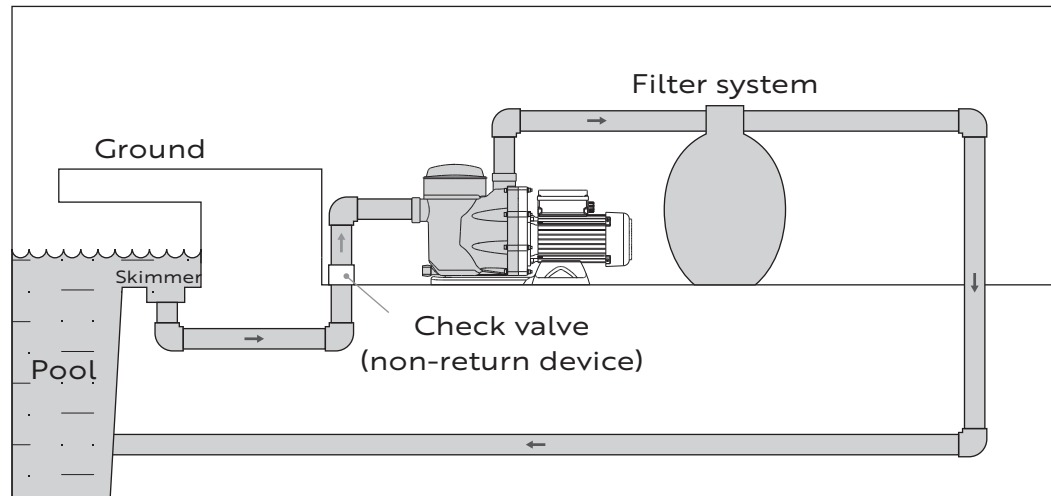

7. Above-Ground Pool: The pump inlet is positioned below the water surface, enabling direct flow of water from the pool into the pump.

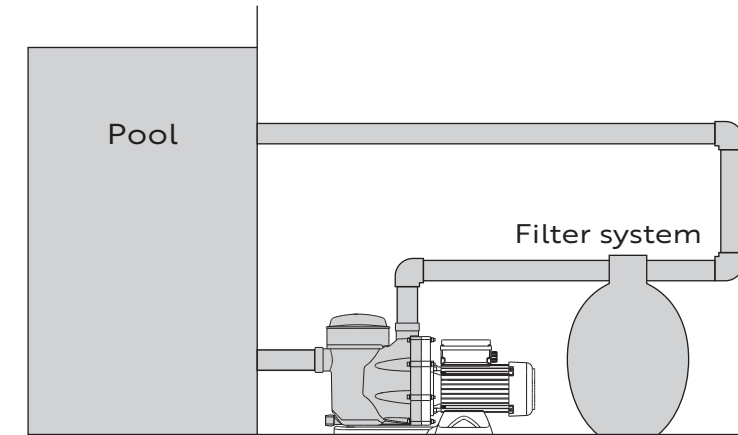

8. Maximum Water Temperature: 50°C

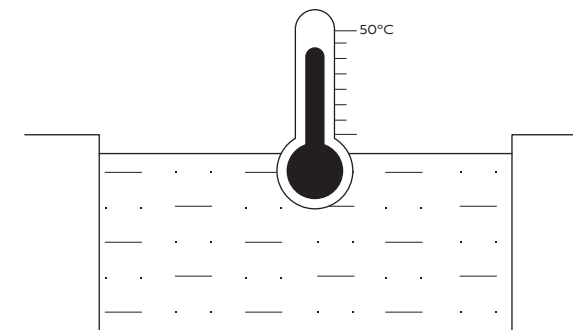

# Packing List

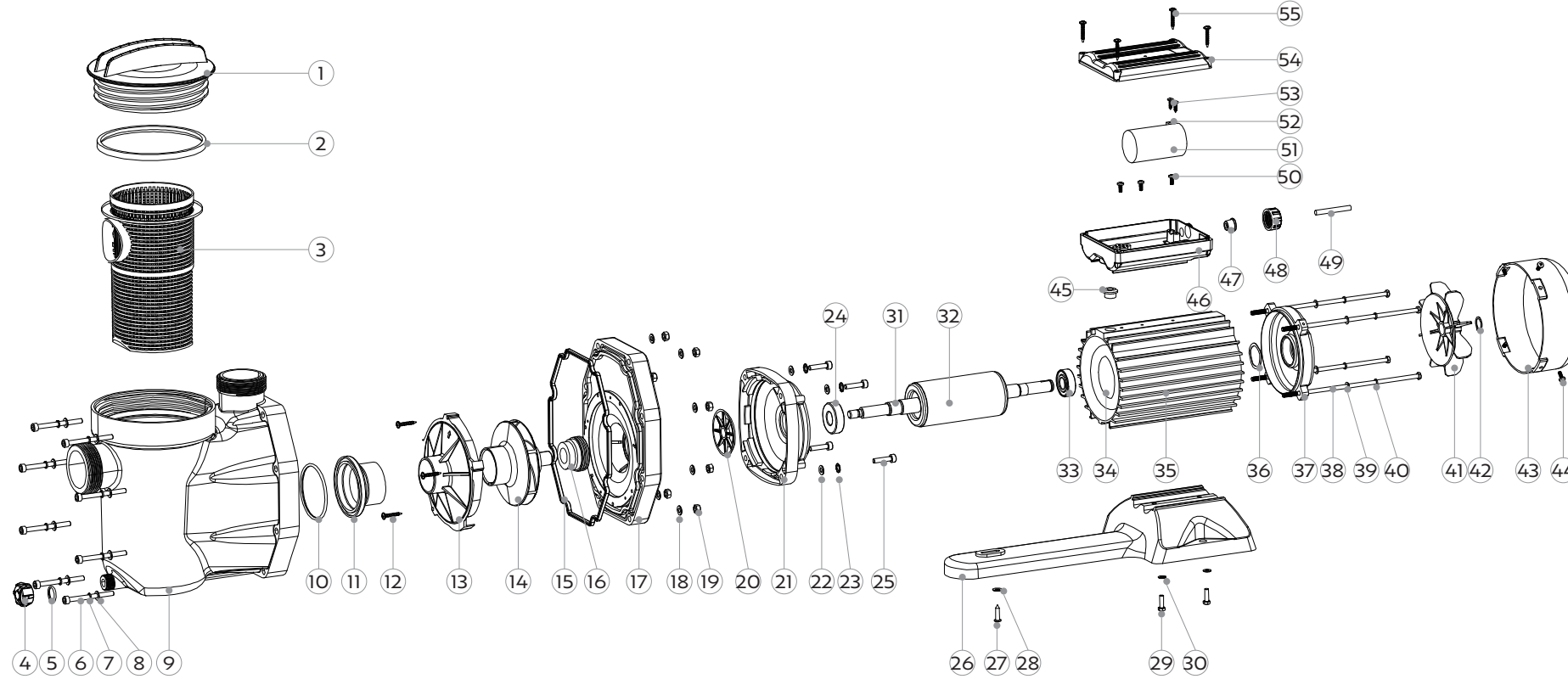

No.	Description
1	Plastic Cover
2	O-Ring
3	Filter
4	Water Nut
5	O-Ring
6	Screw
7	Spring Washer
8	Flat Washer
9	Pump Body
10	O-Ring

No.	Description
11	Casing
12	Screw
13	Diffuser
14	Impeller
15	Machinical Seal
16	O-Ring
17	Bracket Cover
18	Flat Washer
19	Nut
20	Against Hydrosphere

No.	Description
21	Front Cover
22	Flat Washer
23	Flower Mat
24	Bearing
25	Screw
26	The Base
27	Screw
28	Flat Washer
29	Screw
30	Flat Washer

No.	Description
31	Shaft
32	Rotor
33	Bearing
34	Stator
35	Chassis
36	Spring Ring
37	Rear Cover
38	Screw
39	Flat Washer
40	Spring Washer
41	Fan
42	Shaft Card
43	Fan Cover
44	Screw
45	Sheath
46	Terminal Block
47	For The Mouth
48	Nut
49	Power Cord
50	Screw
51	Capacitor
52	Line Pressing Fast
53	Screw
54	Terminal Cover
55	Screw



If you need to connect an extension cord, please follow these steps.

Note that the diameter of the extension cord must not be smaller than that of the power cord of the pool pump.

1. Cut off the power plug.

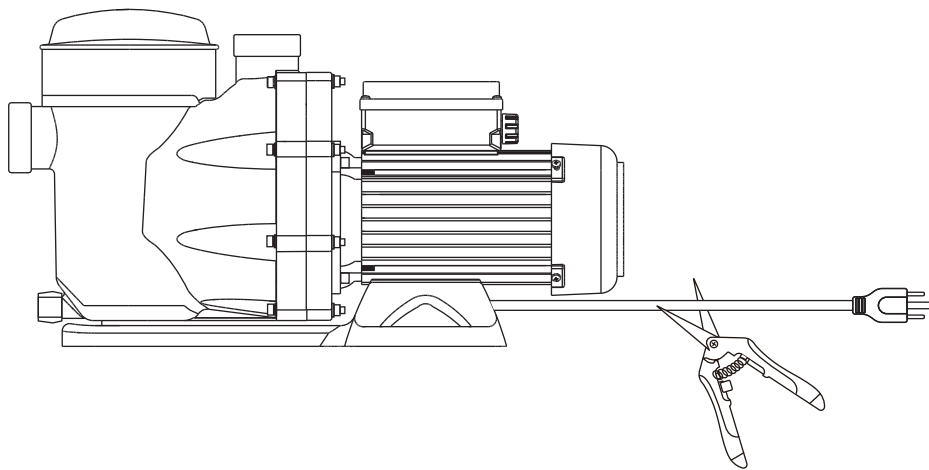

2. Peel off the black cable skin to reveal the 3 wires inside, strip each cable by 2/3 inch with a wire stripper, then strip the insulation to reveal 1/5 inch copper wire. Prepare the wire extension of the pump and repeat the above steps.

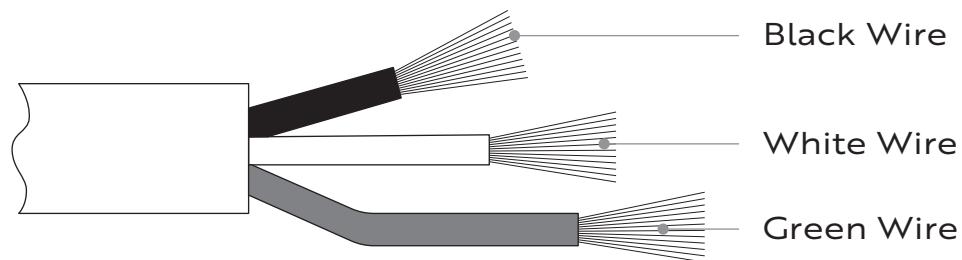

3. Insert the stripped wires into the butt connectors in the wire pigtail from the pump. Firmly crimp each splice with crimping plier to tightly hold the wires in place.

Attention: Please ensure correct matching when wiring an extension cable.

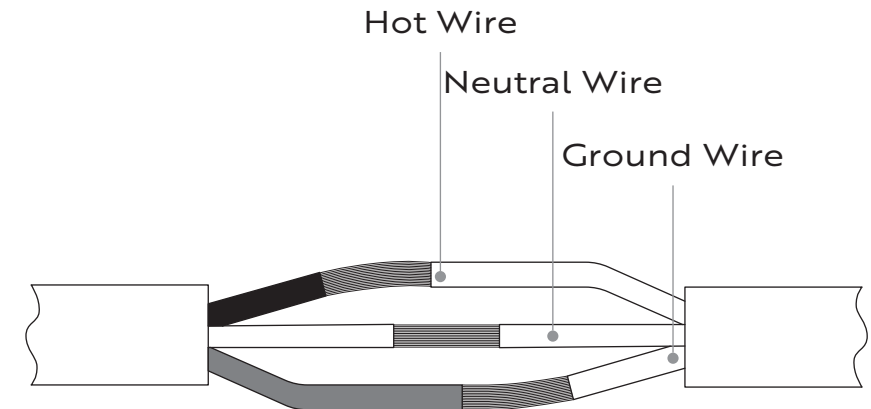

4. Winding the waterproof electrical tape around the butt splice connections of the three strands of wire.

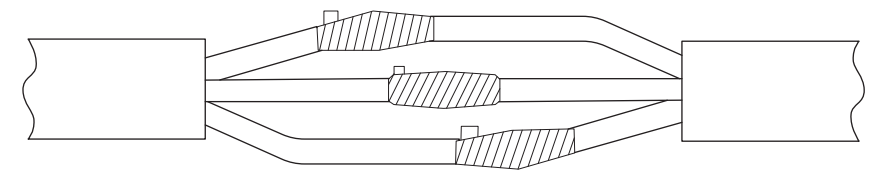

5. Winding the waterproof electrical tape around the wire.

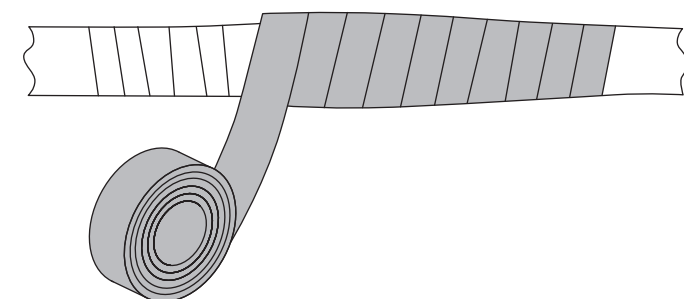

## Pipe Installation



1. The pumps must be positioned as close as possible to the water to minimize the suction distance and reduce head losses.
2. Try to limit head losses by minimizing the length of the suction pipe and avoiding bends and twisty pipe routes as much as possible.
3. Do not add too many elbow pipes in the plumbing so as to avoid suction reduction.
4. Unions must be new and perfectly clean to guarantee absolute tightness.
5. It is recommended not to install the pump more than 10ft above the water level.
6. Use Teflon tape around the thread before screw fittings to pump inlet and outlet ports so as to avoid leakage. Do not over-tighten the fittings.
7. The diameter of the delivery and suction pipes must be greater than or equal to that of the pump inlet and outlet ports.
8. The delivery and suction pipes must not under any circumstances induce mechanical loads on the pump. It is recommended to install suction and delivery valves in order to isolate the pump.

## Pump Installation



1. Before servicing, ensure that all water circulation system and pump controls must be in off position, and release all the pressure from the system.
2. Locate the pump as close to the pool and water level as possible.
3. It is highly recommended to place the pump in a cool and dry location to avoid direct sunlight.
4. Install pump on a firm, level base or pad to meet all local and national codes.
5. Fasten pump to base or pad with screws or bolts to further reduce vibration and stress on pipe or hose joints.
6. The base must be solid, level, rigid, and vibration free.

## Electrical Installation



1. The power supply voltage must be within the range of 90% to 110% of the motor nameplate rated voltage. Otherwise, the motor may overheat and result in overload tripping and reduced component life.
2. Before working on any electrical equipment, turn off power supply to the equipment.
3. Connect only to a branch circuit protected by a ground-fault circuit interrupter (GFCI).
4. All electrical wiring must be in conformance with applicable local codes, regulations, and the National Electric Code (NEC).
5. It is strongly advised to protect the electrical components from direct sunlight though this pump is designed for outdoor use.

## Preparation Before Starting the Pump



1. Check that the mains power voltage and frequency correspond to those indicated on the identification.
2. Check that the pump shaft turns freely.
3. Unscrew the pre-filter cover and fill the pump with water up to the lower level of the suction pipe.
4. Screw firmly the pre-filter cover back in place.
5. If the motor does not start, or if no water is extracted, refer to the table of possible failures and remedies on the following pages.
6. Never operate the pump without water or when the water inlet is being sucked.



**TIMER Button:**  
To set the time.



**ON/OFF Button:**  
Turn pump on/off.

There are two operation modes: continuous mode and single cycle mode.

### Continuous Mode:

1. To set the desired operation period, press the TIMER button: the indicator lights cycle among 2h, 4h, 6h, 8h, 10h, 12h, 16h, and 24h.
2. To start the cycle, press the ON/OFF button, the pump starts running.
3. The built-in timer will now operate for the number of hours selected at the same time each day.
4. For example, if you set the timer to 4h and press **"ON"** at 8:00, the pump will operate for 4 hours and stop at 12:00, and the indicator light will stop flashing. The pump will start again for 4 hours at 8:00 everyday.

## Timer Setting

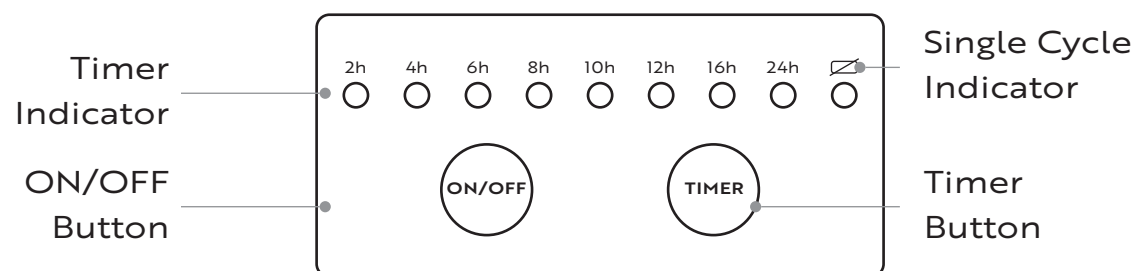

### Single Cycle Mode:

1. When you press and hold the TIMER button for about 5 seconds, the single cycle indicator light will flash, indicating that the mode has switched to single cycle mode.
2. To set the desired operation time, press the TIMER button. The indicator lights cycle among 2h, 4h, 6h, 8h, 10h, 12h, 16h, and 24h.
3. In the single cycle mode, after press **"ON"**, the pump will work for the time set and then stop. It will not work again until you set the timer next time.
4. For example, if you set the timer to 4h in single cycle mode, the pump will stop automatically after running for 4 hours and it will not start again until you set the timer next time.
5. When the single cycle light is on, you can switch back to continuous mode by pressing the TIMER button for 5 seconds.

SECTION I

# Starting the Pump



1. After filling the pump with water, open all the suction and delivery valves, and start the motor. Wait for self-priming to take place.
2. The pump is correctly primed when the water level is just below the transparent cover.

SECTION J

# Troubleshooting



Trouble	Cause	Solution
Pump does not prime.	Excessive suction height	Set pump at a suitable level and install a non-return device.
	Air entry	<ol style="list-style-type: none"> <li>1. Make sure the lid o-ring is clean and properly positioned.</li> <li>2. Remove and replace the pump seal.</li> <li>3. Tighten all pipes and unions on the suction side of the pump.</li> </ol>
	Closed valves or blocked lines	<ol style="list-style-type: none"> <li>1. Open all valves in the system.</li> <li>2. Clean the skimmer and pump strainer basket.</li> <li>3. Open the pump and check for clogging.</li> </ol>

Trouble	Cause	Solution
Pump makes noise.	Air leaks in the suction line if bubbles are observed in water returning to the pool at the inlet.	<ol style="list-style-type: none"> <li>1. Make sure the lid o-ring is clean and properly positioned.</li> <li>2. Remove and replace the pump seal.</li> <li>3. Tighten all pipes and unions on the suction side of the pump.</li> </ol>
	Vibration due to improper mounting, etc.	Put a rubber pad under metal mounting feet.
	Foreign matter (gravel, metal, etc.) in pump impeller	Ask an electrician to disassemble the pump and remove any foreign matter from the impeller.
	<ol style="list-style-type: none"> <li>1. Motor noise</li> <li>2. Defective bearings</li> </ol>	The noise from the motor bearings can be due to normal wear, rust, overheating, or the concentration of chemicals causing seal damage. This damage may allow chlorinated water to seep into the bearings, washing out the grease and causing the bearings to whine. It's important to replace all seal leaks at once to prevent further damage.
	The diameter of the section line is smaller than required.	Ensure that the diameter of the section line is correct.

Trouble	Cause	Solution
Low flow rate	Dirty filter	Backwash the filter when the filter pressure is "high".
	Dirty skimmer basket	Clean the skimmer and pump strainer baskets.
	Air entry	<ol style="list-style-type: none"> <li>1. Make sure the lid o-ring is clean and properly positioned.</li> <li>2. Remove and replace the pump seal.</li> <li>3. Tighten all pipes and unions on the suction side of the pump.</li> </ol>
	Cavitation occurs due to a restricted or undersized suction line, a leak at any joint, low water level in the pool, and unrestricted discharge return lines.	Correct any suction conditions or throttle return lines, if possible. Placing a hand over the return fitting or installing a smaller eyeball fitting can help verify this issue.
	Excessive suction height	Set pump at a suitable level and install a non-return device.
	The diameter of the section line is smaller than required.	Ensure that the diameter of the section line is correct.
	Closed valves or blocked lines	<ol style="list-style-type: none"> <li>1. Open all valves in the system.</li> <li>2. Clean the skimmer and pump strainer basket.</li> <li>3. Open the pump and check for clogging.</li> </ol>

Trouble	Cause	Solution
Motor shuts off.	Undersized wiring or loose connections	Increase the size of the supply wire.
	Low voltage caused by undersized wire or low incoming voltage	<ol style="list-style-type: none"> <li>1. Increase the size of the supply wire.</li> <li>2. The voltage of the motor must be within 6% of the motor nameplate voltage.</li> <li>3. Report the low supply voltage to local power company.</li> </ol>
	Mechanical binding and electrical overload	Call the technical service.
Pump doesn't start.	Motor is blocked.	Call the technical service.
	Centrifugal switch is stuck in the OPEN position.	Open the motor cover and flip the centrifugal switch.
Pump is leaking.	Seals are worn out.	The seal is a wear part that must be changed occasionally, especially if the pump is used with seawater and not flushed with clean water when drained.



In order to keep pump from freeze in winter, please drain the pump properly:

1. Keep the water level below inlet of the pool.
2. Pull out the drain plug from pump strainer body and remove strainer lid.
3. Disconnect the pump from mounting pad, wiring system, and piping system.
4. Once water is drained off from the pump, reassemble the strainer lid and drain plugs.
5. Place pump in a shady and dry area.



HP	2.5
Volts	230
AMP	8.1
Recommended Wire Size 0-50'	No. 12



The VIVOHOME warranty program is our commitment to you. We are committed to providing you with a high-quality product that meets your needs and expectations. To demonstrate our confidence in the durability and performance of our products, we offer the following warranty.

### **WARRANTY COVERAGE**

This warranty program applies to any orders, purchases, receipts, or use of any products sold by VIVOHOME and is valid for a period of 1 year from the date of purchase. However, please note that this warranty period is only valid for the original order. If you receive a replacement order during the warranty period, it will not include a separate warranty period.

### **WARRANTY EXCLUSIONS**

This warranty does not cover damage resulting from misuse, accident, unauthorized modification, or any other circumstances not directly related to the manufacturing and design of the product, including but not limited to:

- Parts lost during use.
- Normal wear and tear of products or parts.
- Incorrect installation (such as using the wrong voltage) or assembly.
- Exceeding the bearing capacity of the product.
- Use under extremely harsh conditions.

- Improper cleaning or maintenance.
- Damage caused by any reason other than the intended use of the product.
- Indirect loss or damage caused by the product.

## **HOW TO MAKE A WARRANTY CLAIM**

If you find any defects that affect the use of the product or if the product stops working and cannot be repaired during the warranty period, please contact our customer service team at our email or via Amazon & app's direct messaging service as soon as possible. Provide the following information to expedite the process:

- Order number
- Images and/or videos illustrating the issue
- A detailed description of the problem

VIVOHOME will provide technical support, replacement, refund, or other solutions based on the nature of the issue. If you wish to return the original package for any reason, please contact us for confirmation before proceeding. You can expect to receive a response within 48 hours.

Thank you for choosing VIVOHOME. We are committed to ensuring the quality and satisfaction of your purchase. If you have any questions or need assistance, please do not hesitate to contact our customer service team.