

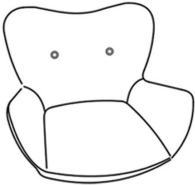



Assembly Instruction



Accessories List

<p>(1) 4 Screws (M6×18)</p> 	<p>(2) Seat Cushion</p> 	<p>(3) Base Tube</p> 	<p>(4) Hexagon Wrench</p> 
<p>(5) 5 Castors</p> 	<p>(6) Air Rod</p> 	<p>(7) Base Plate</p> 	

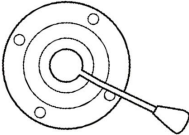
Notice

- Do not stand in this chair or use the chair as a step ladder, use it as chair only.
- This chair is designed for one person to use at a time, weighting up to 300lbs (136kg).
- Do not use this chair unless all bolts, screws and knobs are firmly secured.
- Check all bolts, screws and knobs every 6 months. Tighten if any are loose.
- Failure to follow these instructions may result in serious injury or death of yourself and people around you.
- Some of the parts are heavy and/or have sharp edge, please install it carefully to avoid hurting you and people around you.
- Keep small parts (e.g. screws) out of children's reach to prevent choking hazards.

Instructions for Use

Step 1

Take out Castors (5). Insert Castors (5) into Base Tube (3).

* Caution: Confirm 5 Castors (5) must be inserted deeply. Otherwise the castors could easily fall out and the chair could fall down.

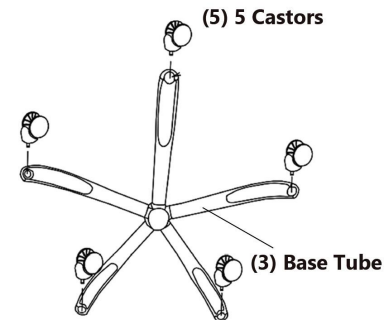

Step 2

Put Air Rod (6) through into the hole of Base Tube (3) as shown.

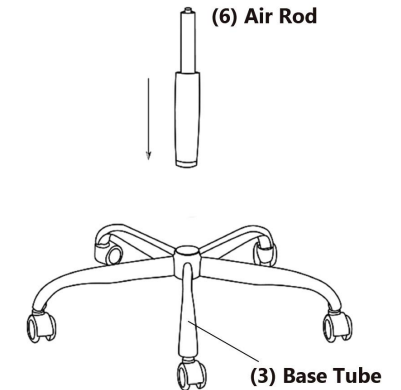

Step 3

Fix Base Plate (7) to the bottom of Seat Cushion (2). Tighten the 4 Screws M6X18 (1) with Hexagon Wrench (4) firmly.

* Caution: There is a FRONT letter print on the front of the Base Plate (7).

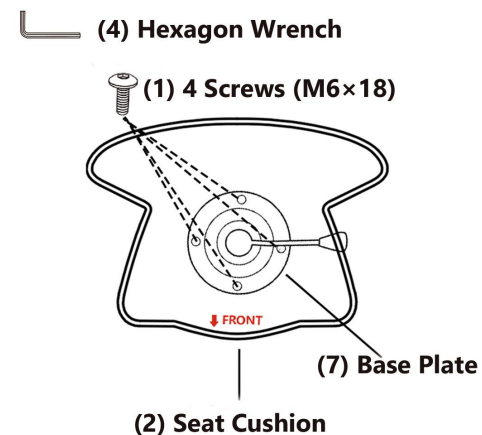

Step 4

Then insert the Air Rod (6) into the Base Plate (7), the Base Plate (7) has holes in the middle. Press the Seat Cushion (2) from top to bottom, with all the strength of your body.

* Caution: If the Air Rod (6) doesn't insert to Base Plate (7) firmly, it's likely to fall off when the chair rises up.

