

INSTRUCTION MANUAL

Wicker Bar Stool

User Manual

Thank you for choosing our wicker bar stools. If you are satisfied with your shopping experience, we provide some suggestions for you to express your happiness:



1. Share your positive shopping experience with your family and friends.
2. Write a review to let others know about your satisfaction.

If you encounter any issues such as missing or broken parts, or if you need further assistance, please contact our customer service online via email.

Notice:

1. Before fully tightening all screws, it is recommended to initially tighten them by 50%. We suggest using an electric drill to expedite the assembly process.
2. Ensure the item is placed on a flat surface to guarantee stability.
3. If the screws do not align with the holes during assembly, please loosen all the other screws by 50% and continue the assembly process.
4. If the item is not stable, please loosen all the screws, readjust it on a flat surface, and then tighten all the screws once again.

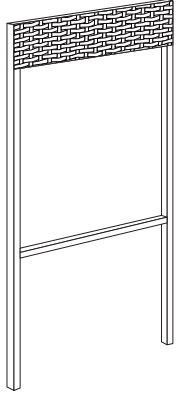
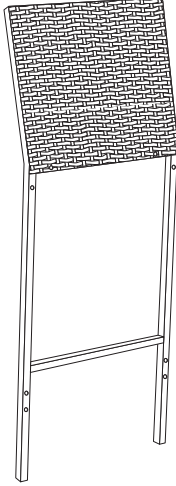
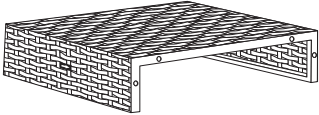
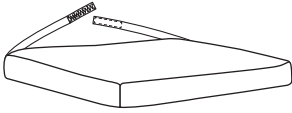
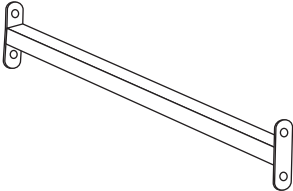
Parts List

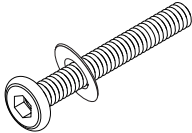
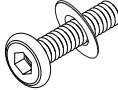
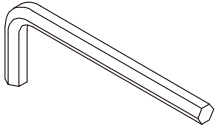
Item no.	Reference Image	Qty.	Item no.	Reference Image	Qty.
1		X2	4		X2
2		X2	5		X2
3		X4	6		X2
A	 M6x35 mm.	X16	B	 M6x15 mm.	X16
	 Assembly Tool	X1			

STEP 1

1 x 1 pc.

2 x 1 pc.

A x 4 pcs.

Use Part A screws (4 pcs.) to connect Part 1 (1 pc.) and Part 2 (1 pc.).
Note: Please note that the arrow indicates the front direction.
You need to align the front of the seat frame with Part 1

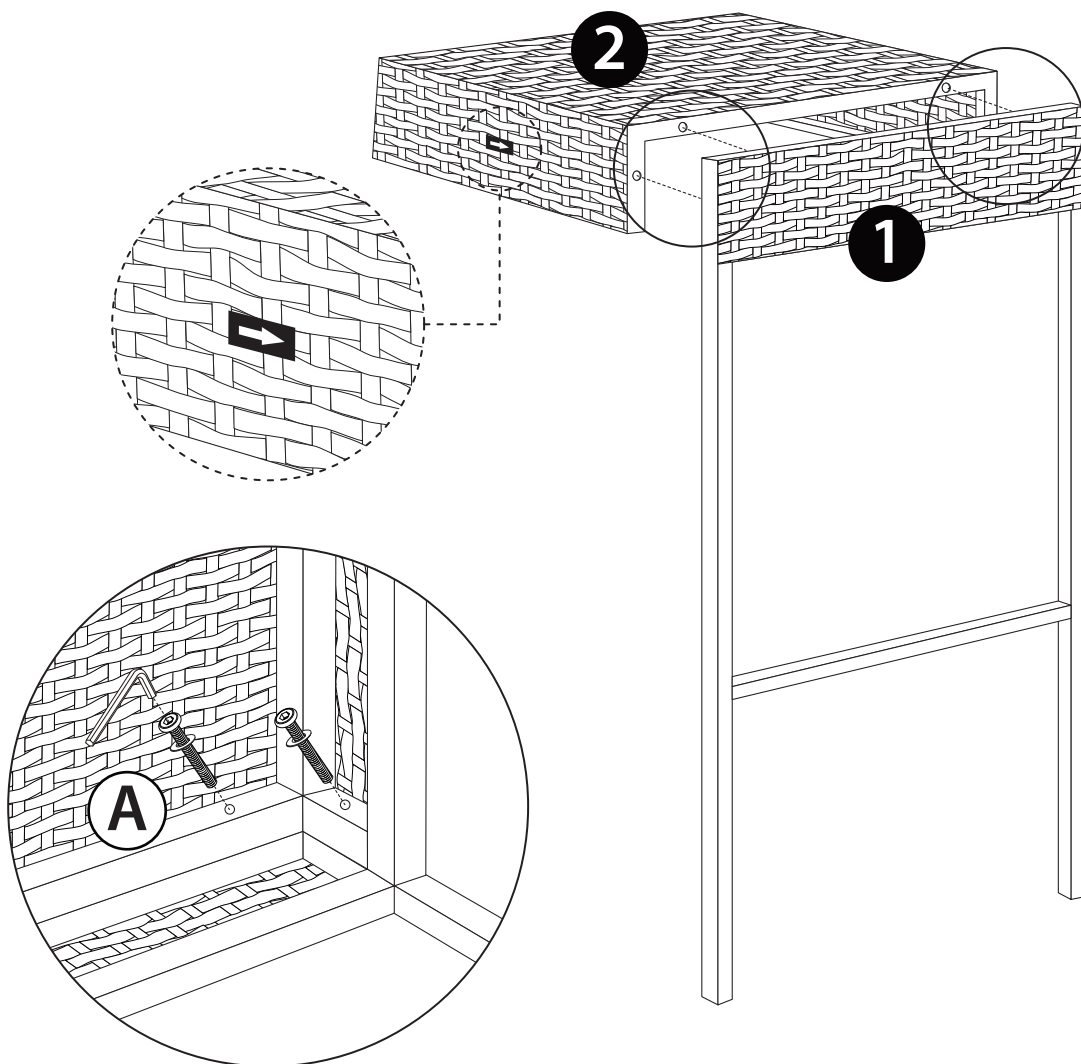

STEP 2

3 x 2 pcs.

B x 4 pcs.

Use Part B screws (4 pcs.) to connect Parts 3 (2 pcs.) and Part 1 (1 pc.).
Note: Please note that the arrow indicates the front and upward direction.

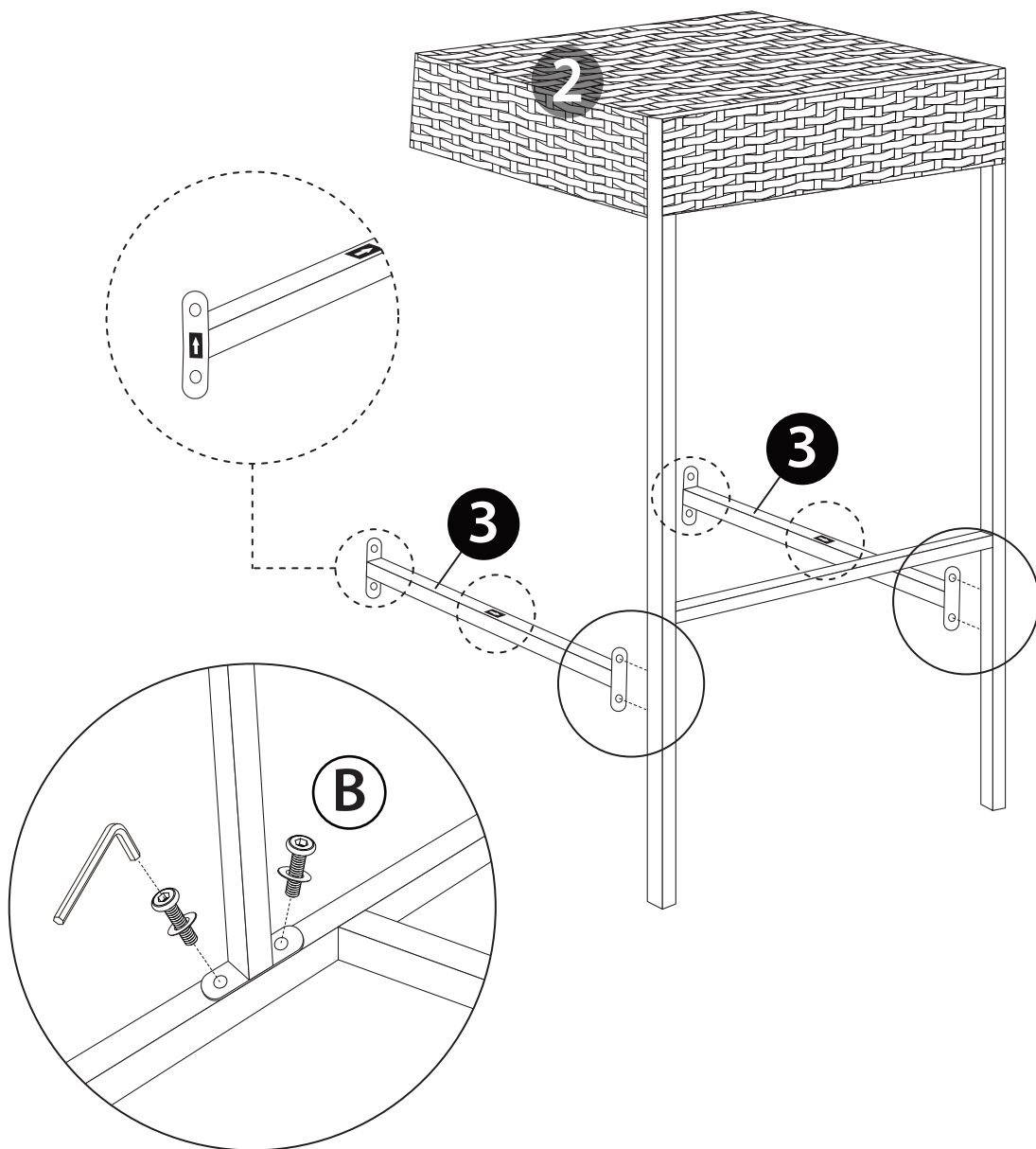

STEP 3

4 x 1 pc.

A x 4 pcs.

B x 4 pcs.

Connect Part 4 (1 pc.) to the main body with Part A screws (4 pcs.) and Part B screws (4 pcs.).

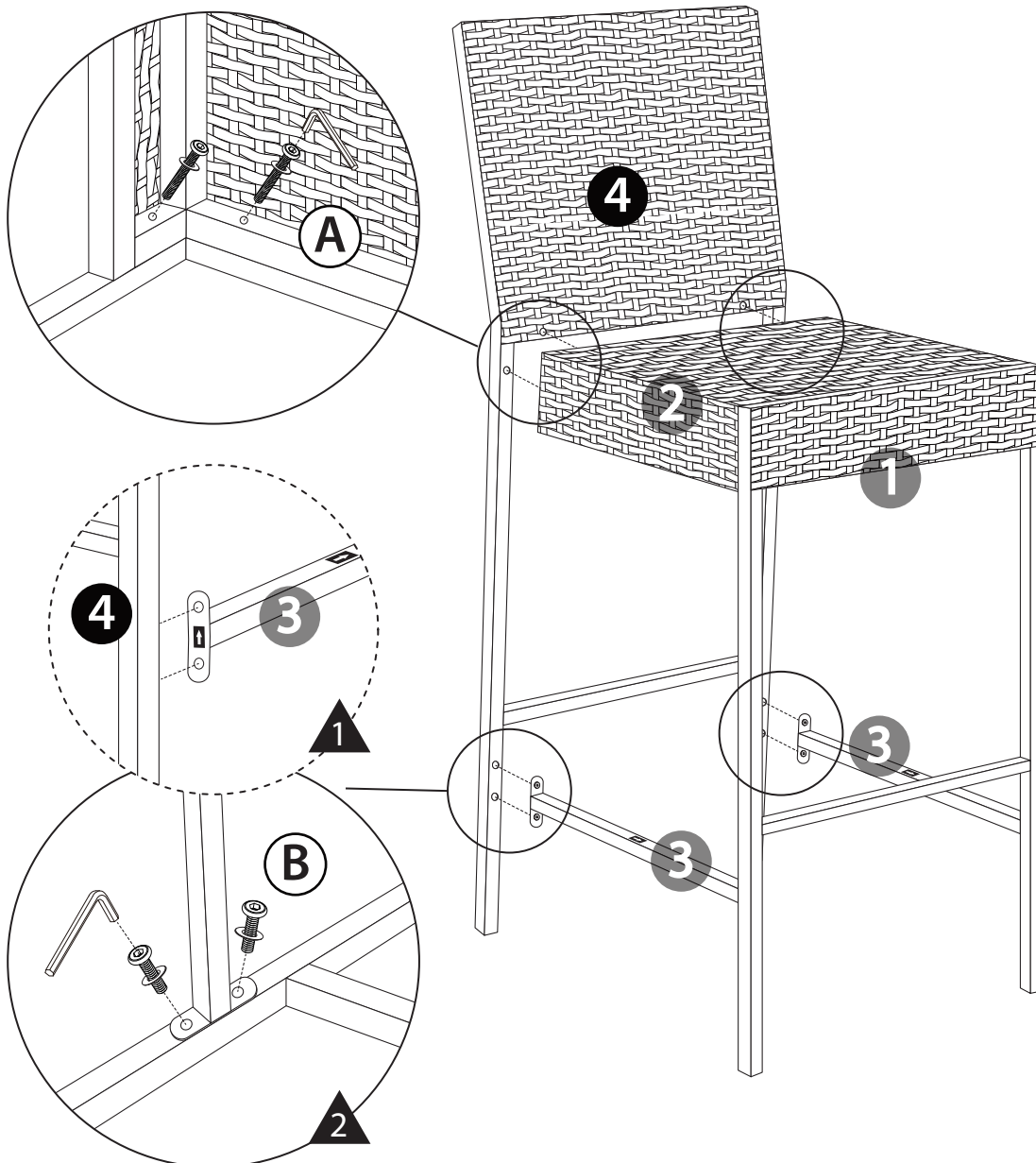

STEP 4

5 x 1 pc.

6 x 1 pc.

Connect Part 5 (1 pc.) and Part 6 (1 pc.) to the main body, as shown in the picture.

