



Parts and Damage Replacement Procedure

1. Please inspect your purchase immediately.
2. This procedure covers product purchased from an authorized Roundhill Reseller and was received in its originally sealed carton.
3. If you find a part missing or damaged, you have a 30-day window in which to order a replacement part from the date on your purchase receipt.
4. You have 3 ways to do this. You will need a copy of your purchase receipt.
 - a. By Fax: Fax the parts order form below and along with your receipt to 614-878-7918
 - b. By Email: Email the order form and along with your receipt to: parts@roundhillfurniture.com
 - c. By Mail: Fill out the parts order form below and along with a copy of your receipt send it to Roundhill furniture parts department 3640 Zane Trace Drive, Columbus OH 43228
5. Once this order is sent in, you will be notified if the part(s) you are requesting can or cannot be shipped within 7-10 business days.

**A COPY OF YOUR PURCHASE RECEIPT OR INVOICE MUST BE ATTACHED TO THIS ORDER FORM.
NO ORDERS WILL BE PROCESSED WITHOUT PROOF OF PURCHASE.**

NAME: _____
 ADDRESS: _____ (No Post Office Boxes)
 CITY: _____ STATE: _____ ZIP: _____
 PHONE: _____ FAX: _____
 EMAIL: _____

REASON FOR REPLACEMENT/PLEASE CHECK APPROPRIATE BOX.

- Damaged /scratched, cracked, broken, crushed, etc.
- Mechanical malfunction/ drawer glides, swivel mechanisms, lid stays, etc.
- Missing pieces
- Unfinished surface
- Wrong color
- Other

IF MORE THAN ONE MODEL NUMBER IS LISTED ABOVE, PLEASE SPECIFY THE EXACT MODEL NUMBER OF YOUR ITEM IN THE SPACE PROVIDED BELOW.

| Model Number | Part Letter Code | Quantity |
|--------------|------------------|----------|
| | | |
| | | |
| | | |

CARING FOR YOUR FURNITURE

Protect your investment

- The beauty of furniture care is that it helps to protect your investment, as fine furniture is an important purchase
- Proper care will help maintain your furniture's finish and ensure that it looks great year after year

• Caring for furniture

- Caring furniture is easy. Following a few simple guidelines will help extend the life of your furniture

- Always dust with a cloth moistened with polish. Polish cushions the cloth, eliminating the scratching that occurs with dry dusting. Dust will scratch furniture if not removed quickly. Use a soft clean cloth that won't scratch the surface. Avoid coarse or scratchy materials or fabrics
- Avoid using soap and water on furniture. Water can penetrate the finish and raise the grain on wood that cause damage to furniture.

• The Enemies Of Furniture

- Many common problems in furniture care are caused by the elements. If you are aware of these trouble makers the resulting damage can easily be avoided

- Sunlight's ultraviolet rays can damage wood finishes. Arrange furniture out of direct sunlight use sun screening intense sunlight hours rotate furniture in place and room arrangement
- Liquid spills will damage furniture if not removed promptly. Use coasters under beverage glasses and saucers under cups and flowerpots. If a spill occurs. Immediately blow it gently without rubbing the surface.
- Heat creates a chemical change in the furniture finish. Which can result in a white spot. Use protective mats under hot dishes, utensils or cooking appliances
- Cyclic changes in temperature can damage furniture. Placing furniture near to central heating radiator and air dust should be avoided because this causes extreme localized drying of the wood

• Tips For Better Dusting

- Be sure to use the same type of polish consistently. Your furniture will appear cloudy or streaky if oil based or wax based polishes are interchange
- Always use a fine furniture polish when dusting. Never dry dust as it could cause scratches on your furniture's surface. Remember to change dusting cloths frequently since a dirty cloth may scratch your furniture's surface.
- Spray your furniture surface evenly but not too generously. Wipe in a circular motion with a soft clean cloth.
- Then buff until completely dry for a beautiful shine and smudge free finish. For wood trim spray polish on the cloth first then dust.

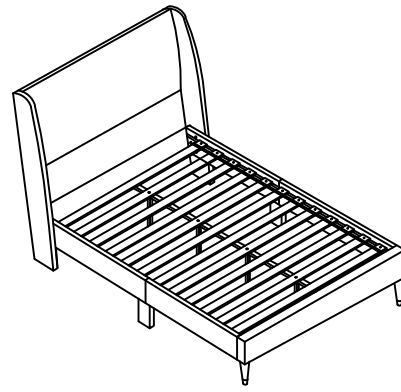

B0112-Q

PARTS

#1 x 1pc



Headboard above

#2 x 1pc



Headboard below

#3 x 1pc

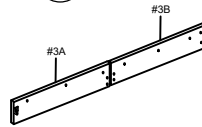

Rail Left

#4 x 1pc

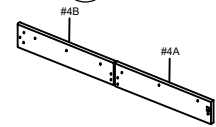

Rail Right

#5 x 1pc



Footboard

#6 x 1L + 1R



Wing

#7 x 2pcs



Rail Leg

#8 x 2pcs



FB Leg

#9 x 4pcs



Support Rail

#10 x 4pcs



Support Leg

#11 x 1pc



Support Slat

#12 x 1set

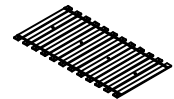

Slat (12pcs)

HARDWARE

#A x 24pcs

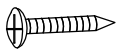

Screw #8x38mm

#B x 10pcs



Bolt Ø5/16" x 1 -1/2"

#C x 4pcs



Bolt Ø5/16" x 1-1/4"

#D x 6pcs



Bolt Ø1/4" x 3/4"

#E x 12pcs



Bolt Ø1/4" x 1-1/2"

#F x 8pcs



Bolt Ø1/4" x 1"

#G x 10pcs



Flat Washer
Ø5/16"x19mm

#H x 4pcs



Flat Washer
Ø5/16"x22mm

#I x 14pcs



Lock Washer Ø5/16"

#J x 26pcs



Flat Washer Ø1/4"x16mm

#K x 26pcs



Lock Washer Ø1/4"

#L x 3pcs



Connecting iron

#M x 1pc



Allen Wrench M5

#N x 1pc



Allen Wrench M4

#P x 8pcs

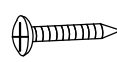

Screw #8x15mm

#Q x 4pcs



Connecting iron

ASSEMBLY INSTRUCTIONS

STEP 1

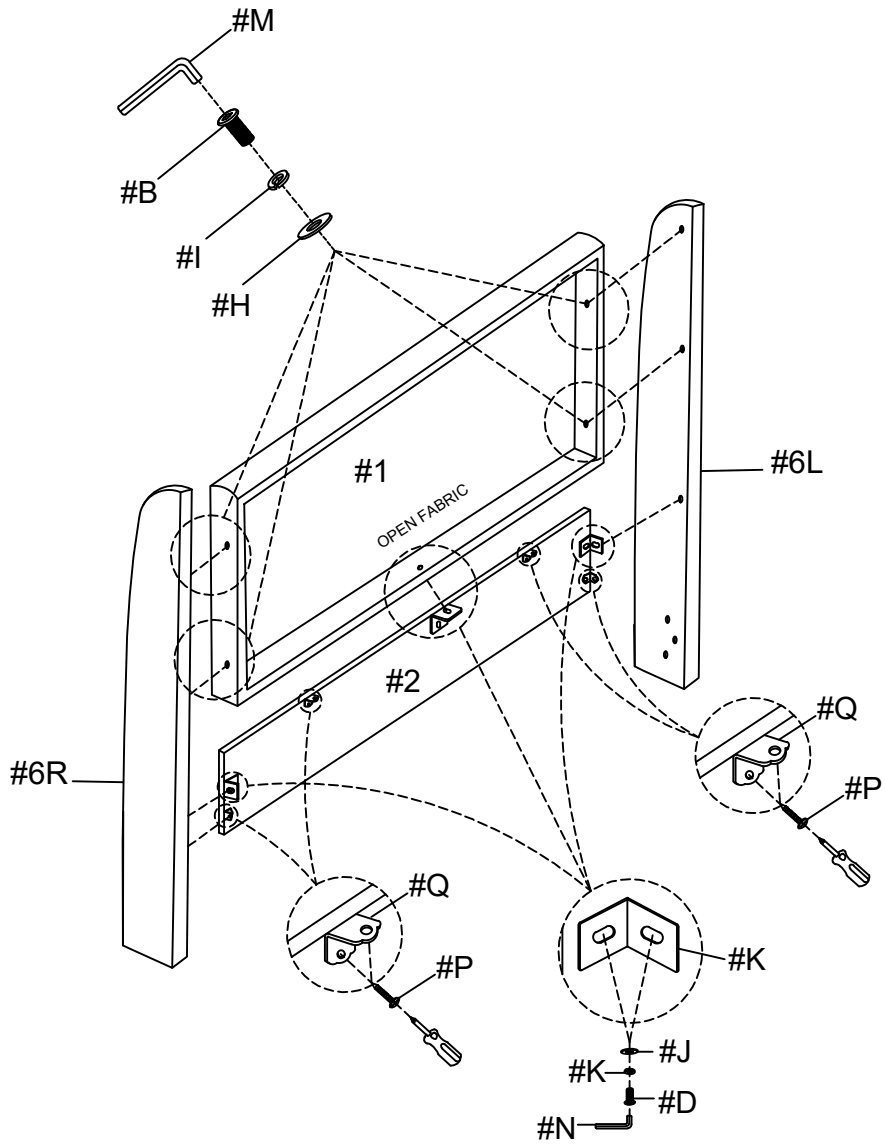

STEP 2

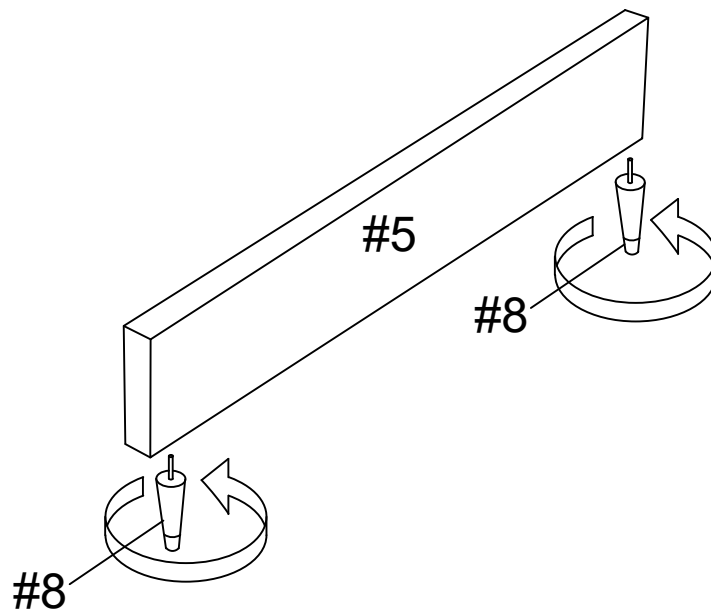

ASSEMBLY INSTRUCTIONS

STEP 3

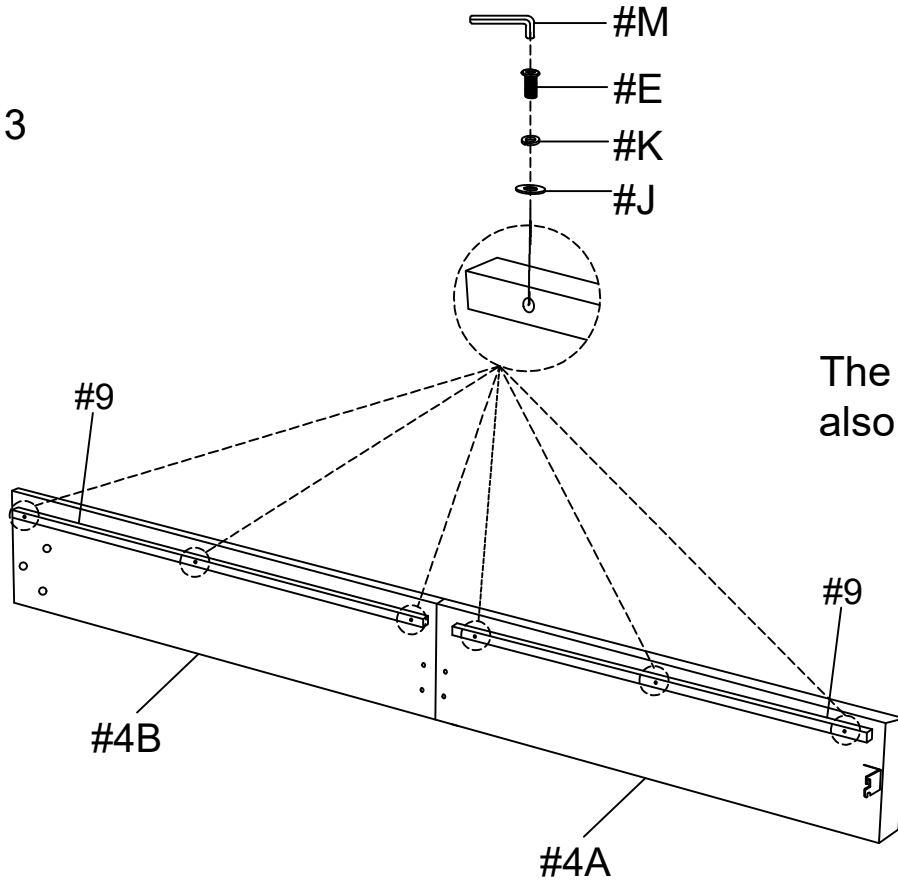

The left side rail (#3) is also installed similarly

STEP 4

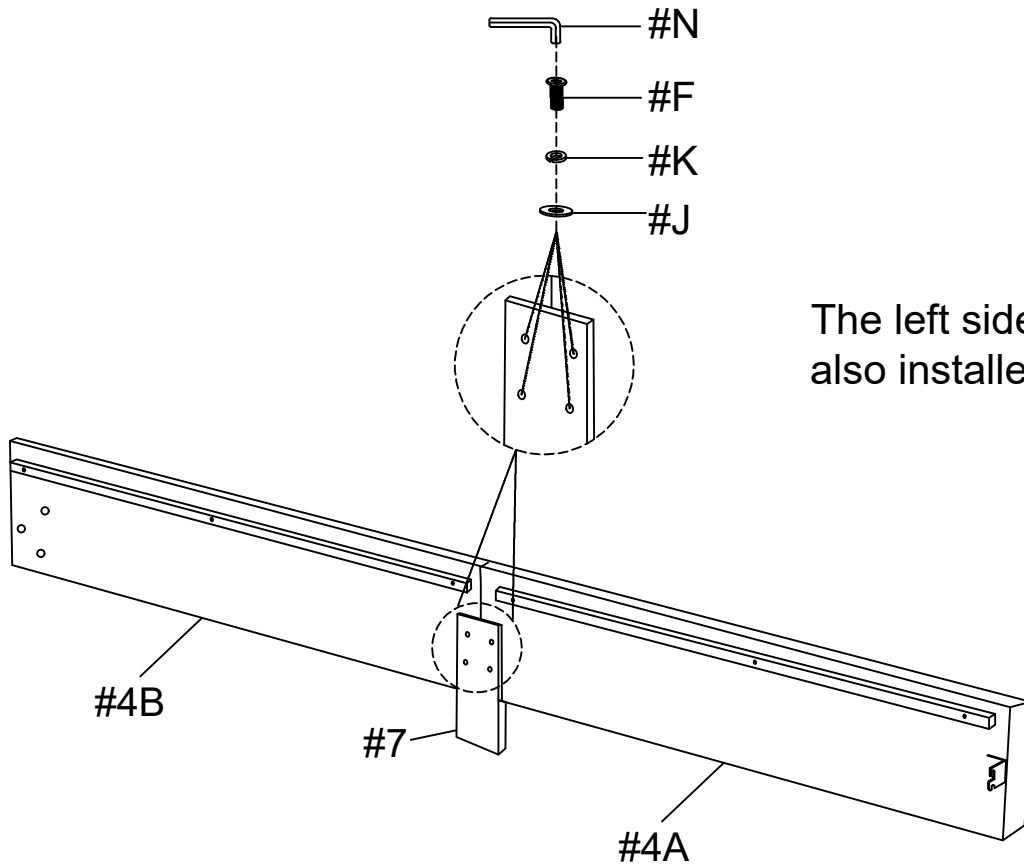

The left side rail (#3) is also installed similarly

ASSEMBLY INSTRUCTIONS

STEP 5

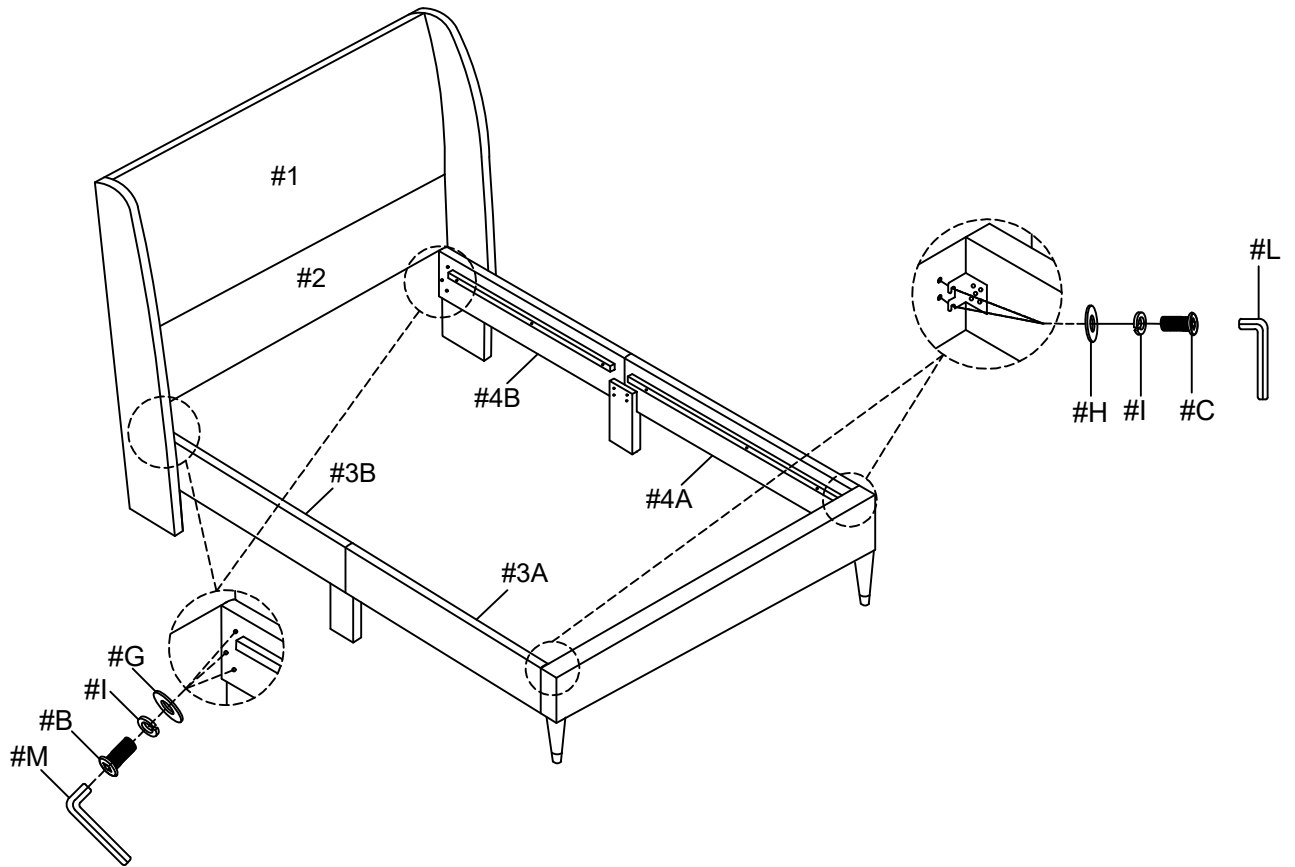

STEP 6

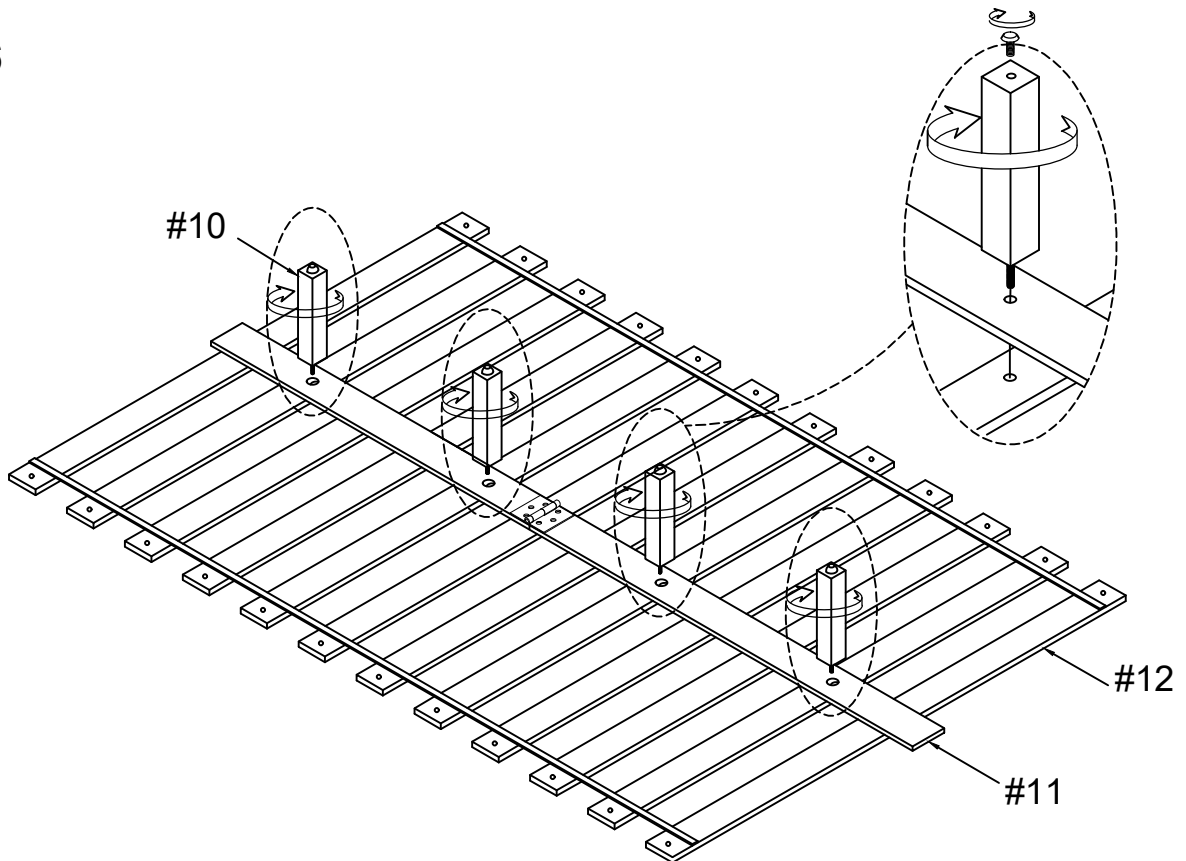

ASSEMBLY INSTRUCTIONS

STEP 7

