

# Installation & Assembly

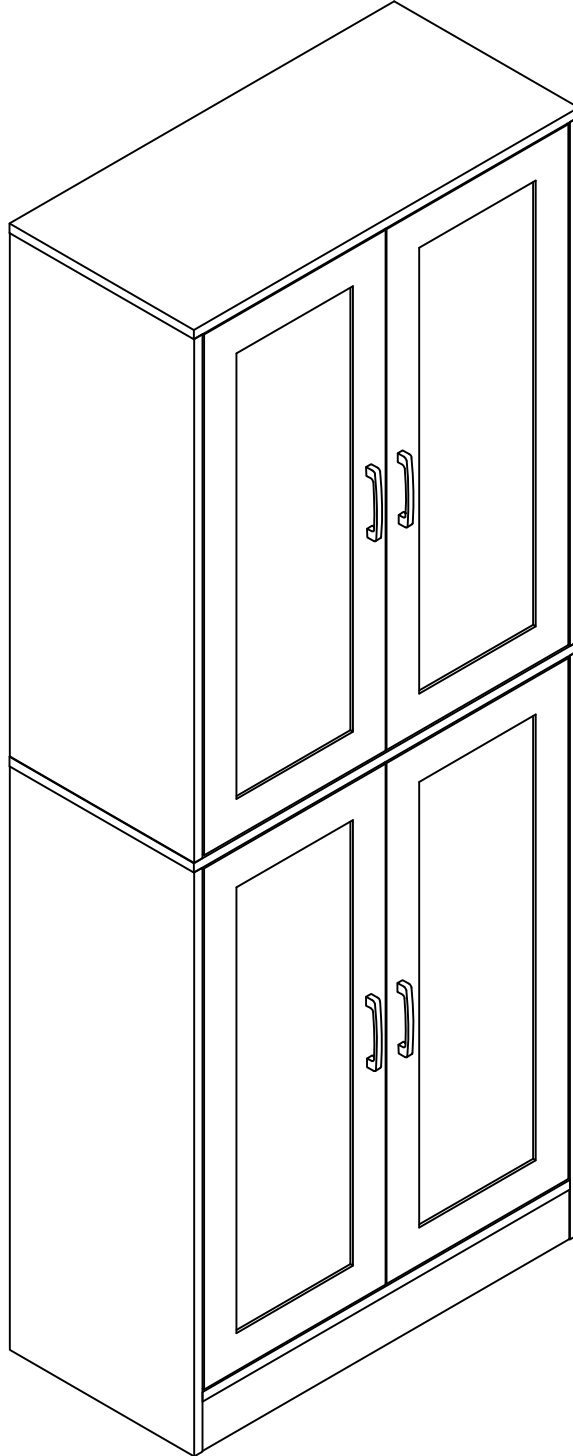

Storage Cabinet

## WARNING

Serious or fatal injury may occur from unexpected assembly or use.

1. During the assembly process, keep all parts away from babies or children.
2. Always securely fix this product to the wall. Make sure the wall area to be drilled is free from hidden electrical wires, water and gas pipes.
3. Use of tip-over restraints may only reduce, but not eliminate the risk of tip-over.
4. Unless specially designed to accommodate, do not set heavy objects on top of this product.
5. Place the heaviest items on the lowest shelf.
6. Never allow children to climb or bang on drawers, doors or shelves.

## WARNING



**Children have died from furniture tipover. To reduce the risk of furniture tipover:**

- **ALWAYS** install tipover restraint provided.
- **NEVER** put a TV on this product.
- **NEVER** allow children to stand, climb or hang on drawers, doors, or shelves.
- **NEVER** open more than one drawer at a time.
- Place heaviest items in the lowest drawers.

Parts List (EN) / Teile Liste (DE)

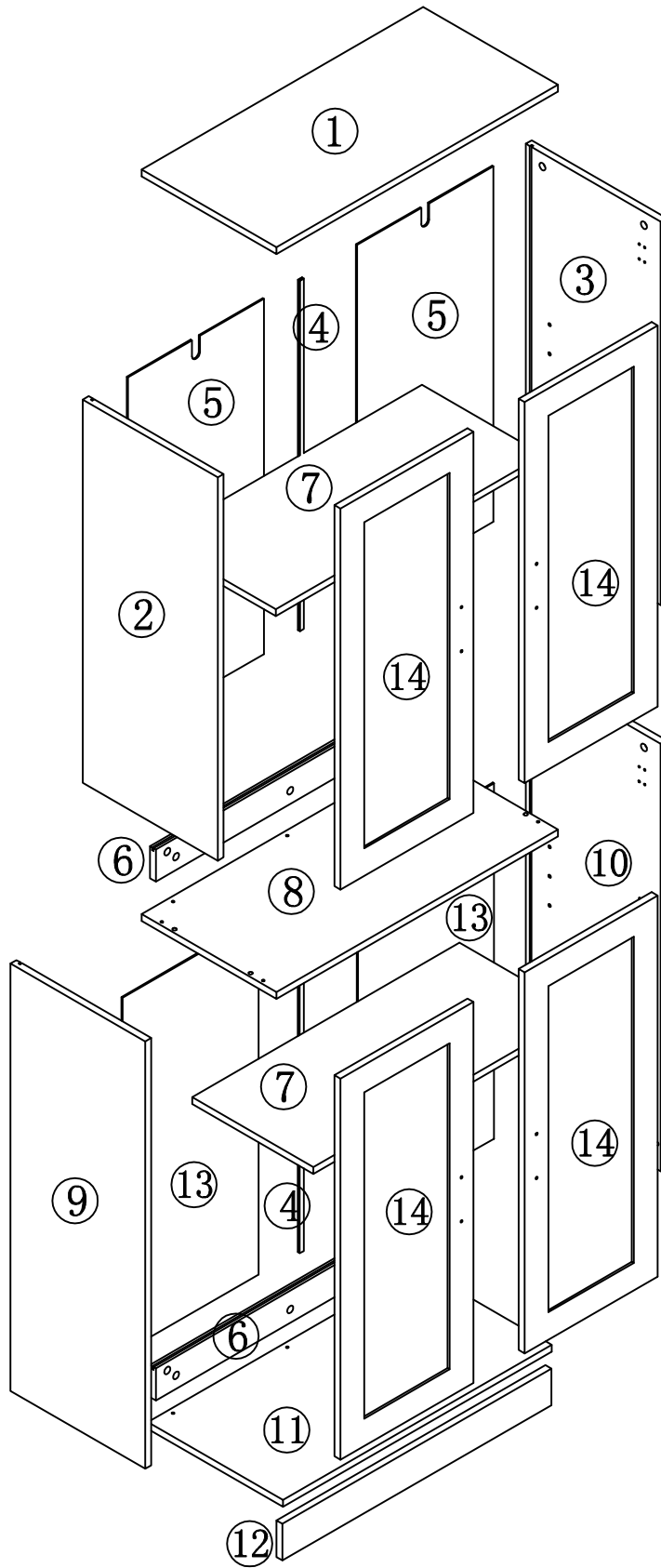

# Parts List(EN)/Teile Liste(DE)

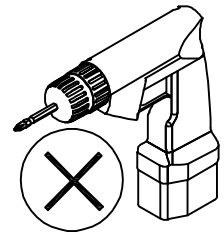
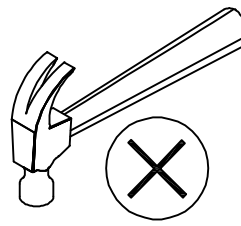
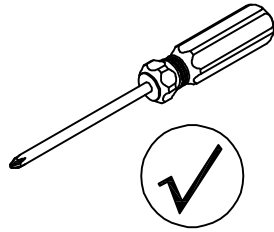
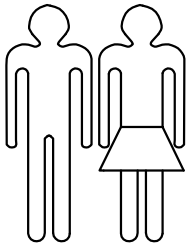

<p>①</p> <p>710*340*15mm</p> <p>1PC</p>	<p>②</p> <p>837*340*15mm</p> <p>1PC</p>
<p>③</p> <p>837*340*15mm</p> <p>1PC</p>	<p>④</p> <p>765mm</p> <p>2PCS</p>
<p>⑤</p> <p>776*343*3mm</p> <p>2PCS</p>	<p>⑥</p> <p>678*70*15mm</p> <p>2PCS</p>
<p>⑦</p> <p>674*306*12mm</p> <p>2PCS</p>	<p>⑧</p> <p>one side 710*340*15mm</p> <p>the other side 1PC</p>
<p>⑨</p> <p>933*340*15mm</p> <p>1PC</p>	<p>⑩</p> <p>933*340*15mm</p> <p>1PC</p>
<p>⑪</p> <p>one side 678*340*15mm</p> <p>the other side 1PC</p>	<p>⑫</p> <p>678*80*15mm</p> <p>1PC</p>



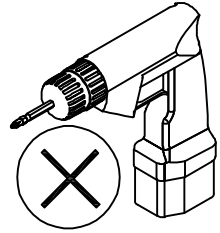
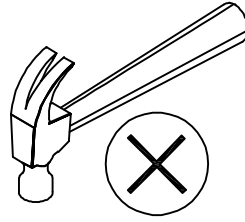
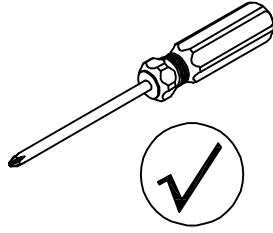
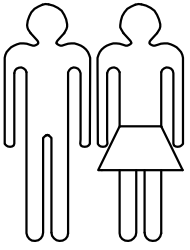

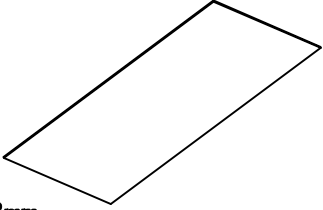
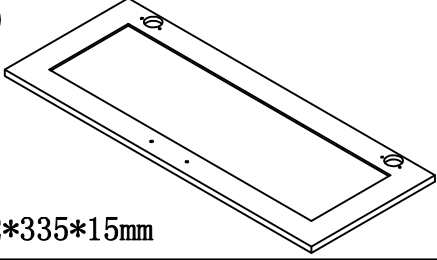

# Parts List (EN) / Teile Liste (DE)

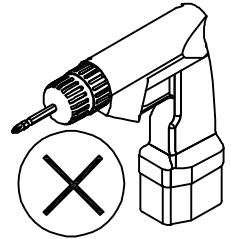
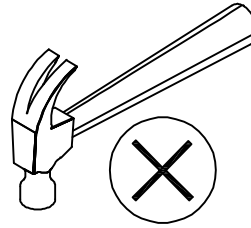
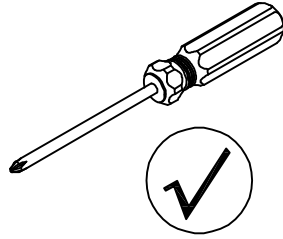
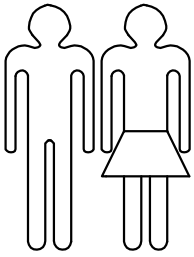

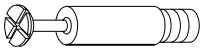
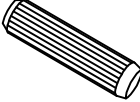
<p>⑬</p>  <p>776*343*3mm</p> <p><b>2PCS</b></p>	<p>⑭</p>  <p>832*335*15mm</p> <p><b>4PCS</b></p>
--	--

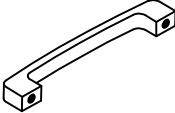
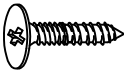
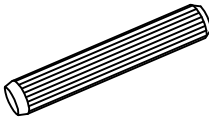
# Hardware List (EN) / Teile Liste (DE)

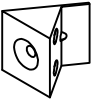
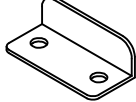
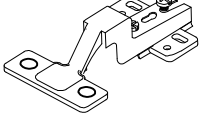
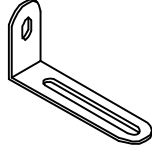
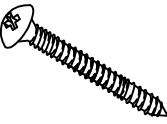
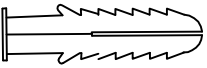

<b>A</b>  $\varnothing 15 \times 9 \text{mm}$ <b>31PCS</b>	<b>B</b>  $\varnothing 6 \times 29 \text{mm}$ <b>31PCS</b>	<b>C</b>  $\varnothing 8 \times 30 \text{mm}$ <b>14PCS</b>	<b>D</b>  <b>M4*20mm</b> <b>8PCS</b>
<b>E</b>  <b>105*22*11mm</b> <b>4PCS</b>	<b>F</b>  $\varnothing 3 \times 15 \text{mm}$ <b>70PCS</b>	<b>G</b>  $\varnothing 8 \times 50 \text{mm}$ <b>4PCS</b>	<b>H</b>  $\varnothing 6 \times 17 \text{mm}$ <b>8PCS</b>
<b>I</b>  <b>14*13*9mm</b> <b>16PCS</b>	<b>J</b>  <b>29*14*9mm</b> <b>2PCS</b>	<b>K</b>  $\varnothing 35$ <b>8PCS</b>	<b>L</b>  <b>70*32*13mm</b> <b>2PCS</b>
<b>M</b>  $\varnothing 4 \times 40 \text{mm}$ <b>2PCS</b>	<b>N</b>  $\varnothing 8 \times 35 \text{mm}$ <b>2PCS</b>	<b>O</b>  $\varnothing 20 \text{mm}$ <b>31PCS</b>	

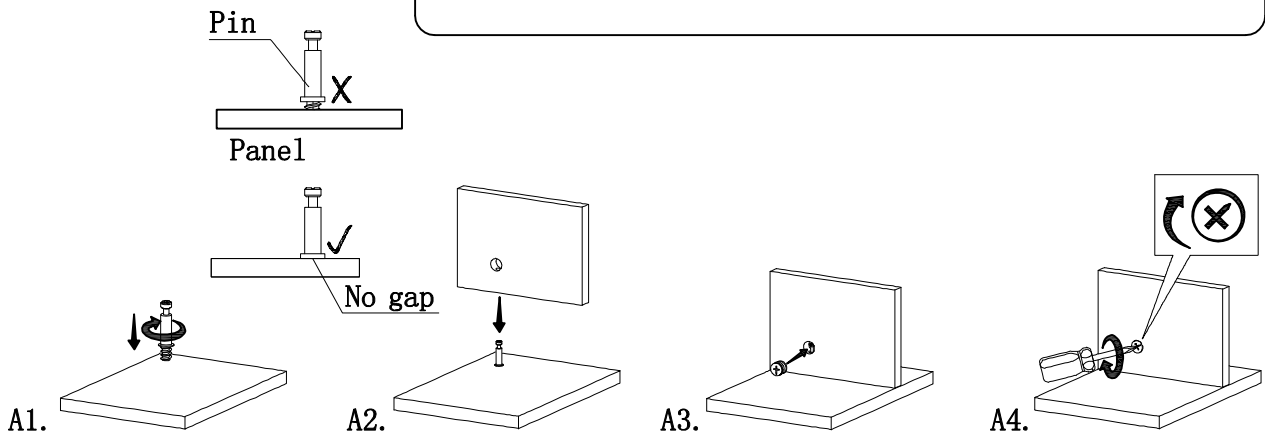
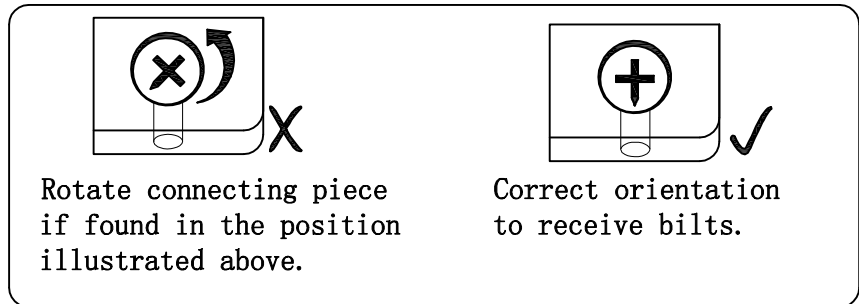
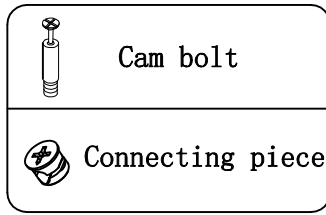

# Assembly (EN) /Montageschritte (DE)

## CAM BOLT INSTALLATION AS BELOW:

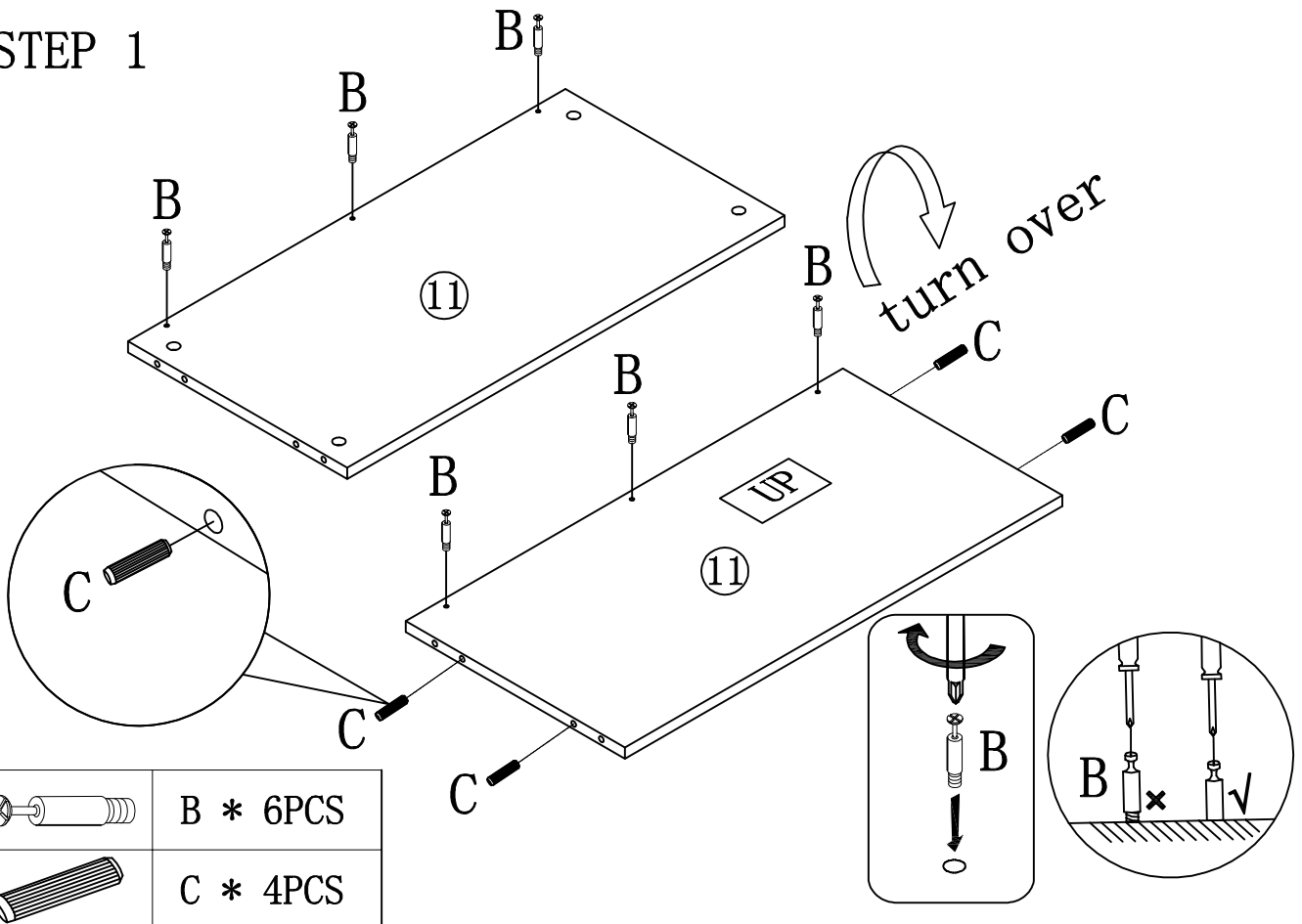

## STEP 1

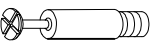

	B * 6PCS
	C * 4PCS

# Assembly (EN) / Montageschritte (DE)

## STEP 2

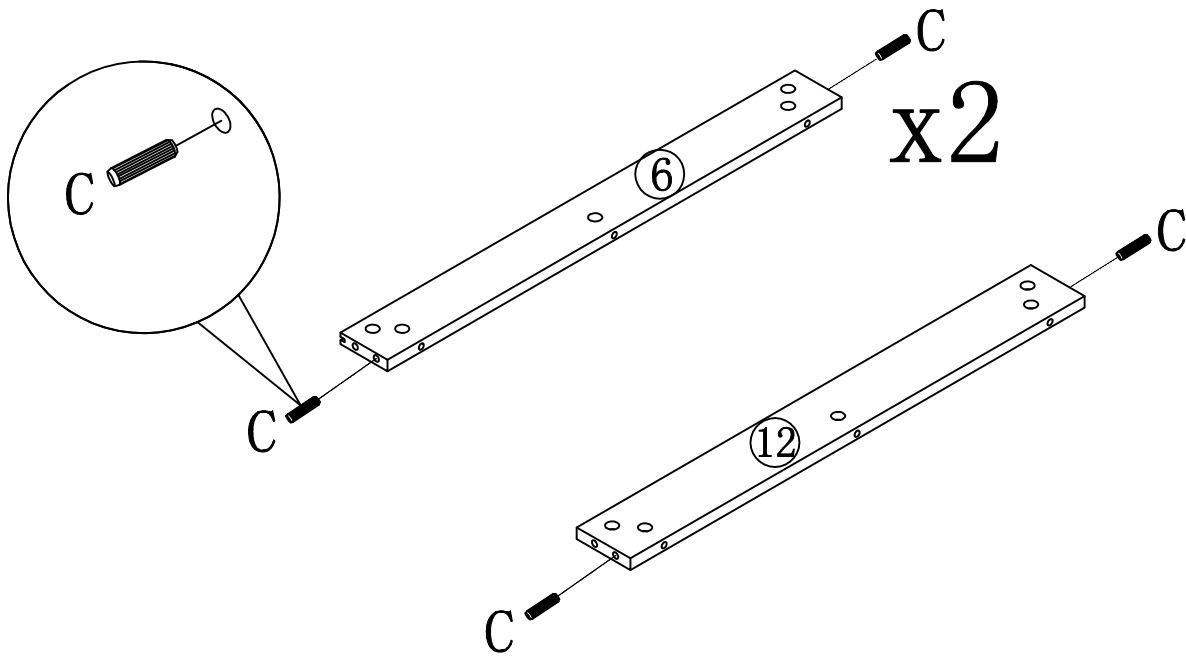

C \* 6PCS

## STEP 3

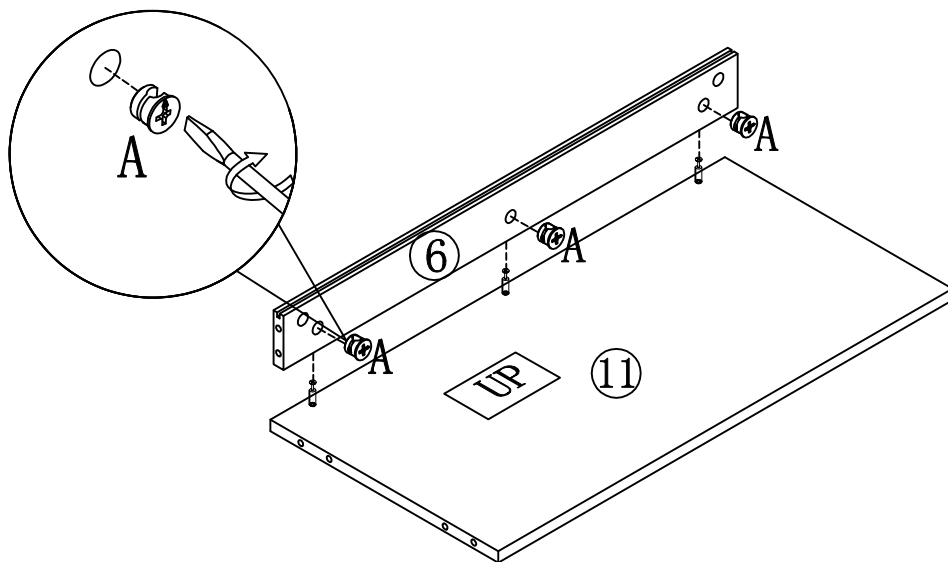

A \* 3PCS

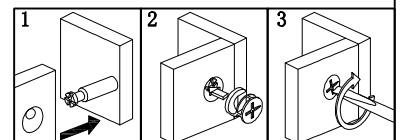

# Assembly (EN) /Montageschritte (DE)

## STEP 4

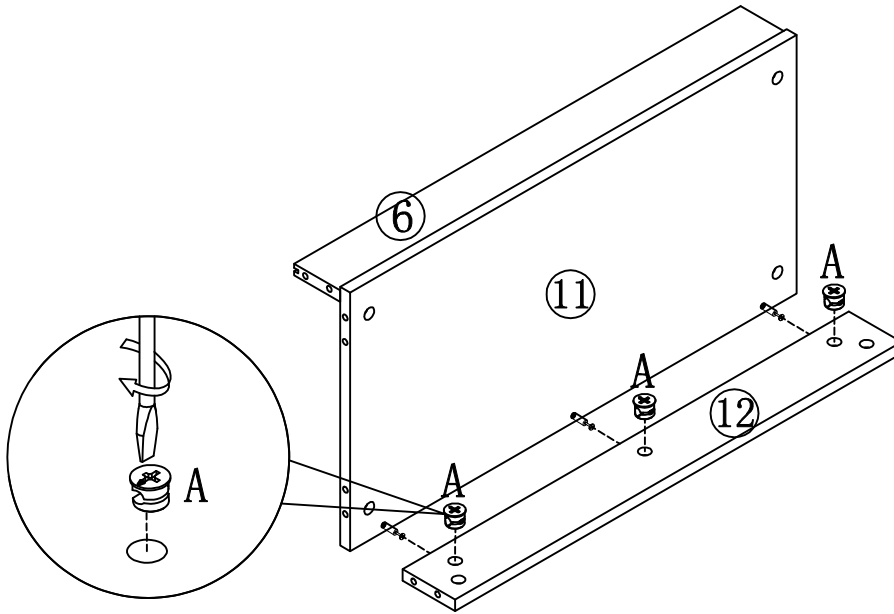

A \* 3PCS

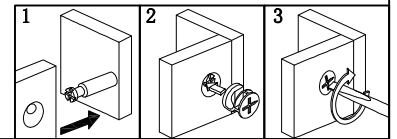

## STEP 5

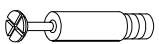
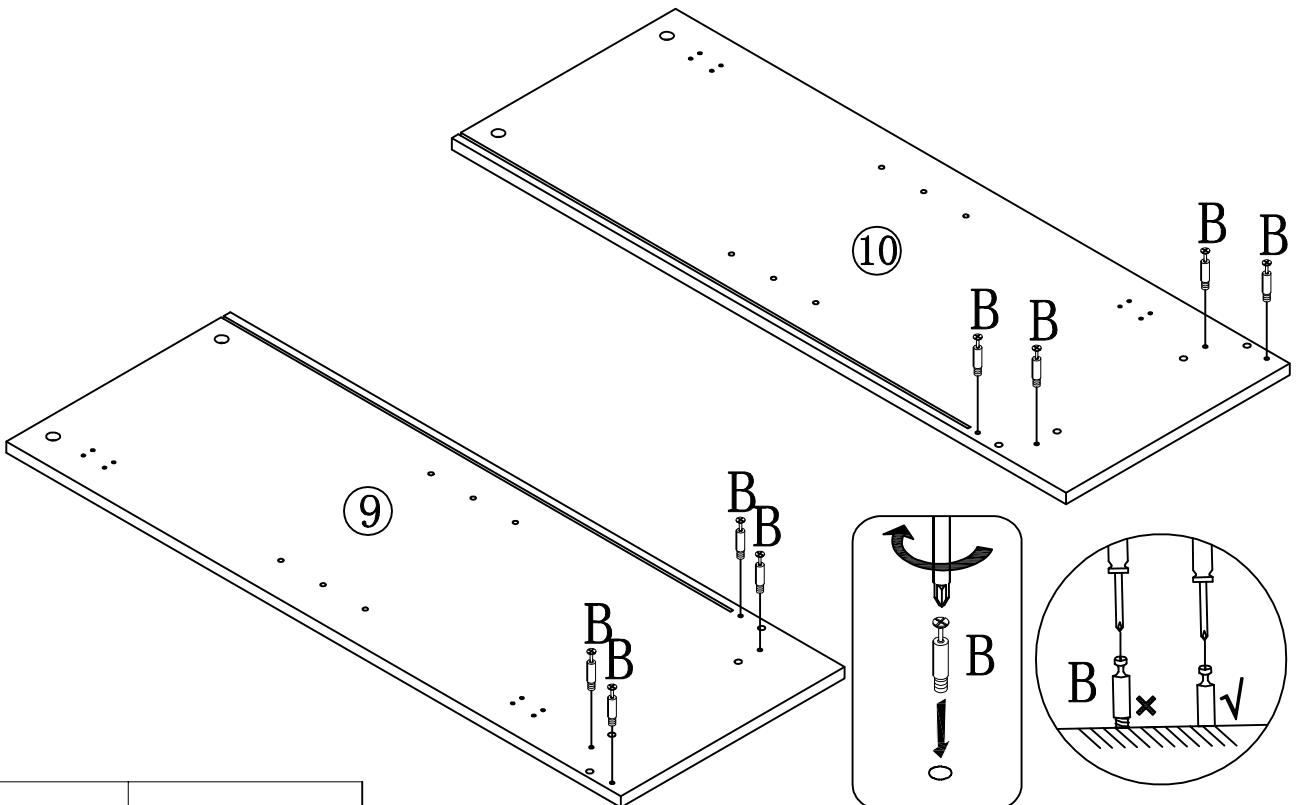

B \* 8PCS

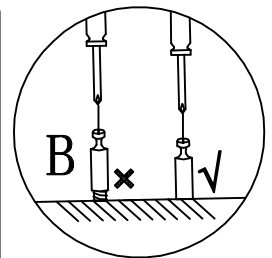
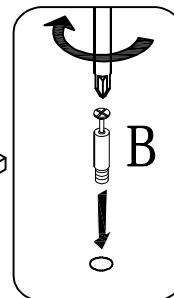

# Assembly (EN) /Montageschritte (DE)

## STEP 6

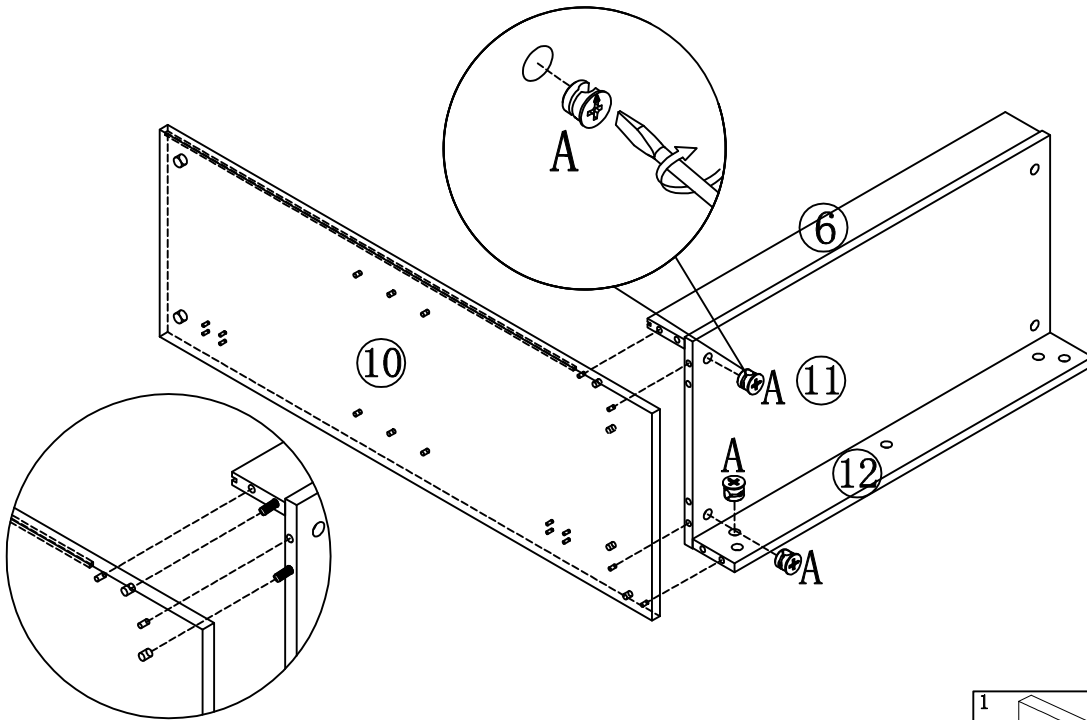

A \* 3PCS

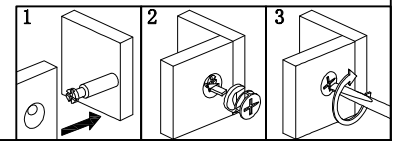

## STEP 7

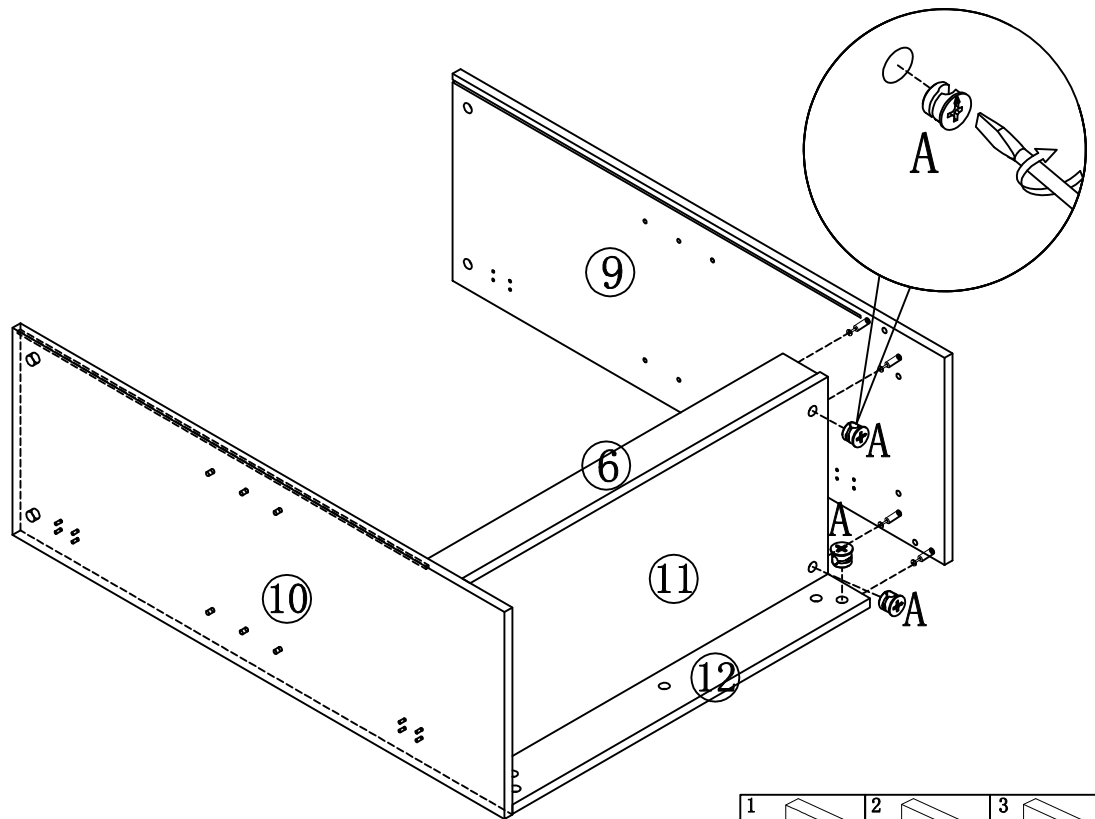

A \* 3PCS

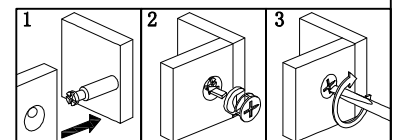

# Assembly (EN) / Montageschritte (DE)

## STEP 8

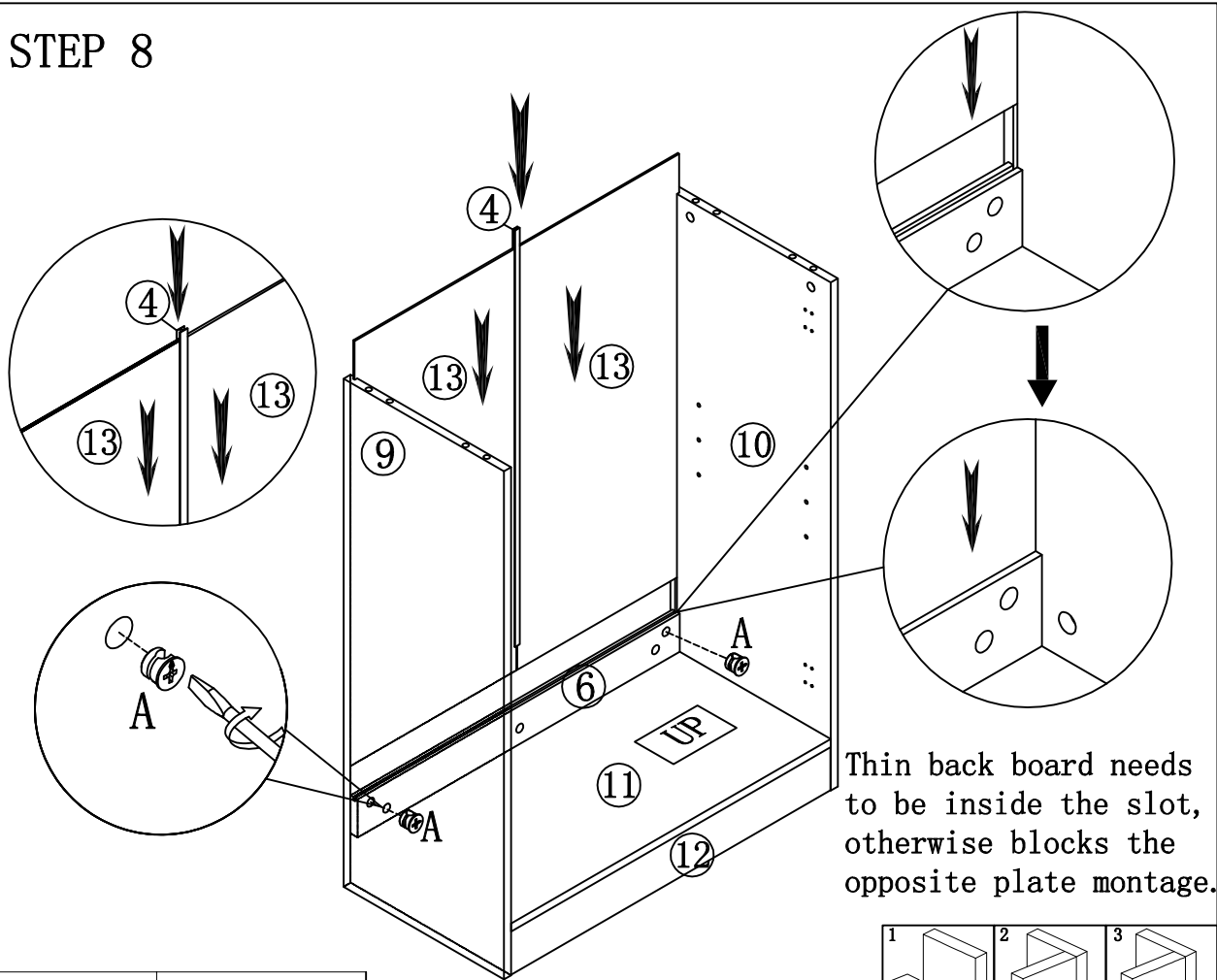

A \* 2PCS

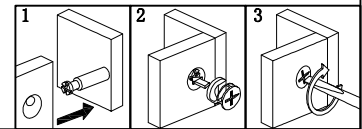

## STEP 9

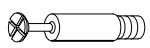
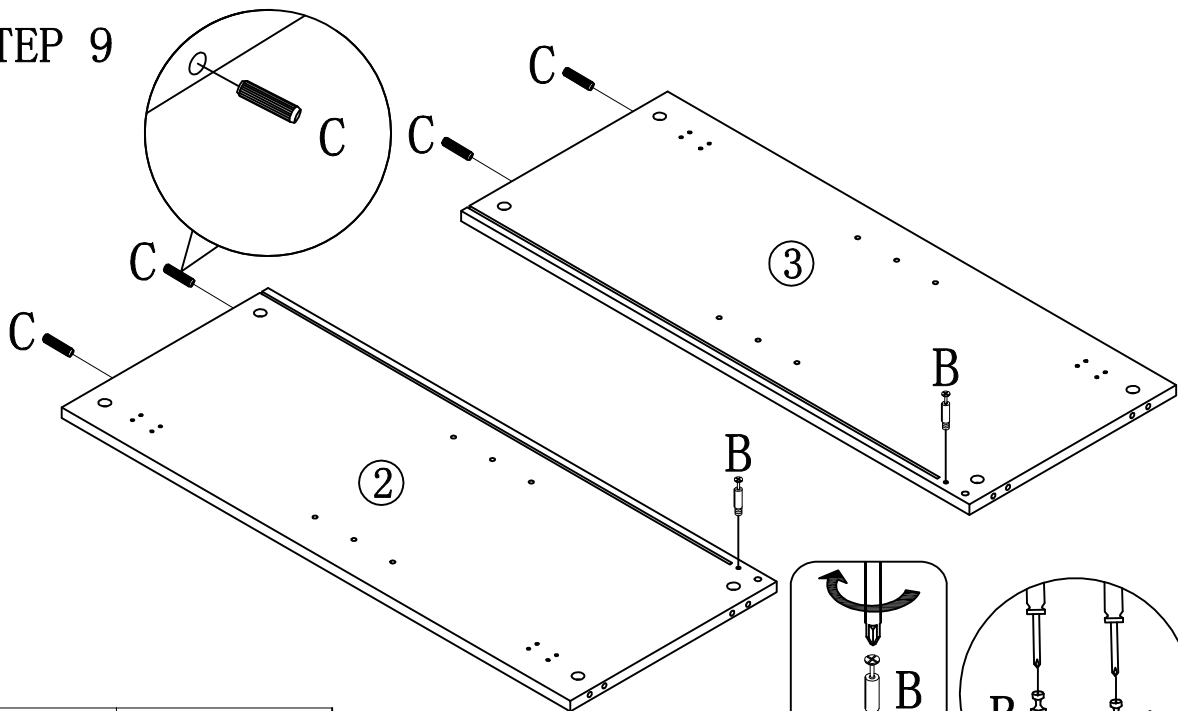

B \* 2PCS



C \* 4PCS

# Assembly (EN) / Montageschritte (DE)

## STEP 10

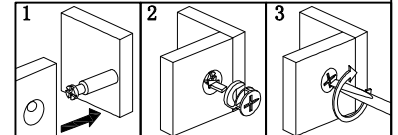
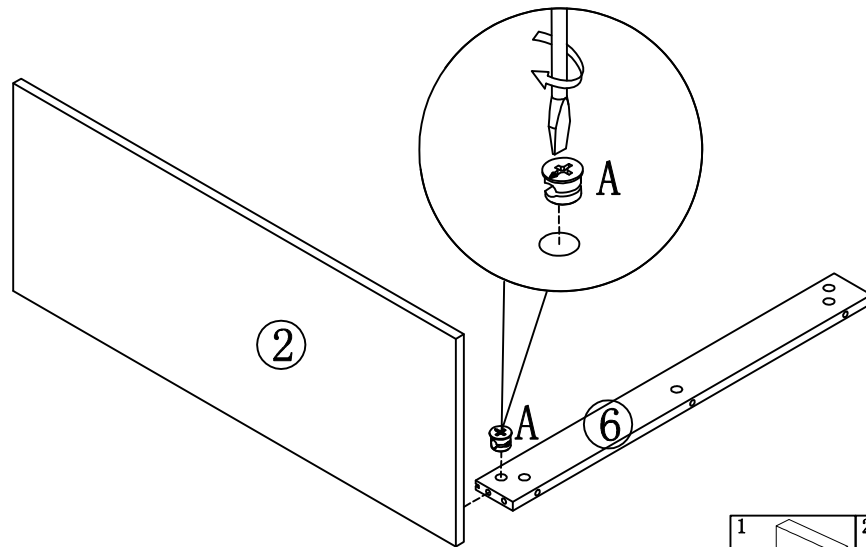

A \*1PC

## STEP 11

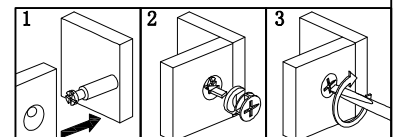
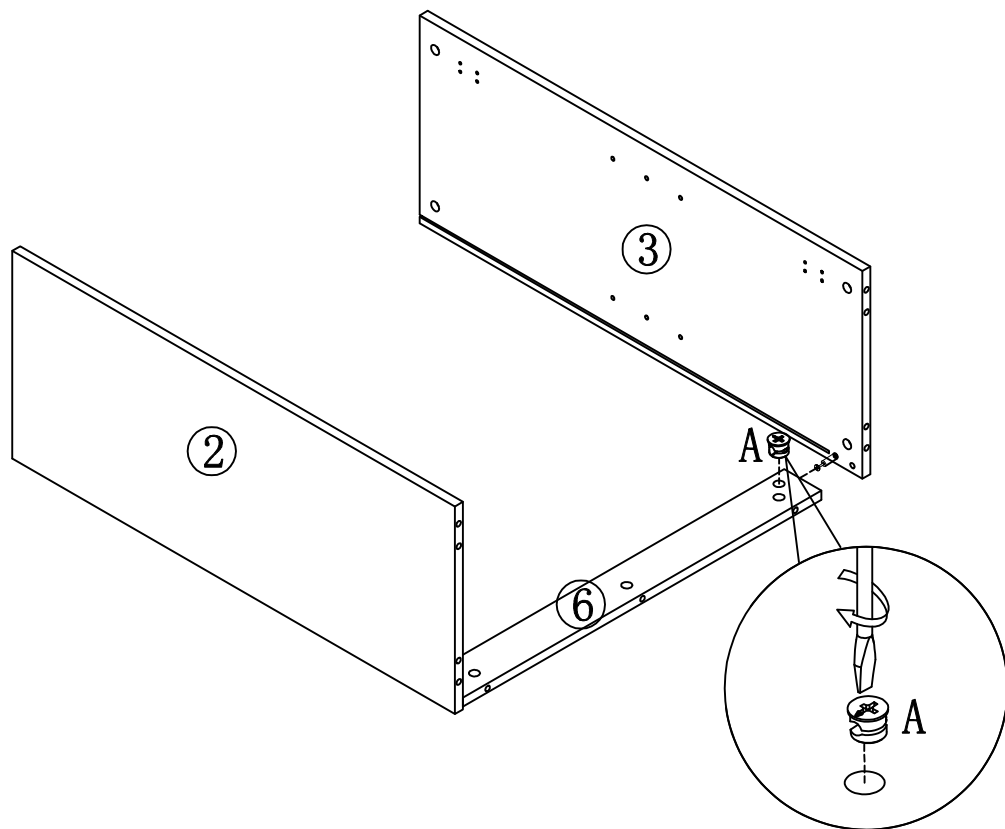

A \*1PC

# Assembly (EN) /Montageschritte (DE)

## STEP 12

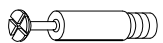
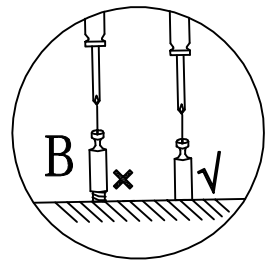
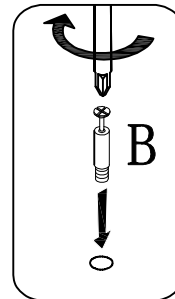
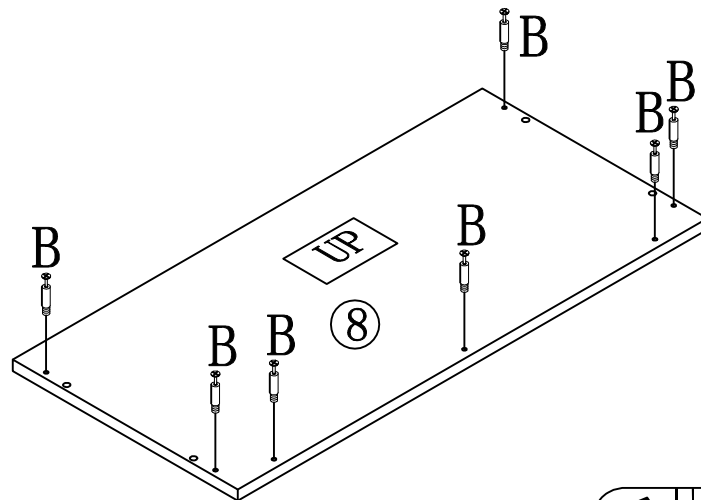

B \* 7PCS

## STEP 13

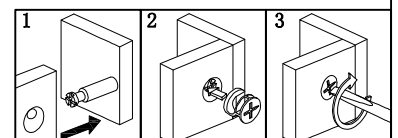
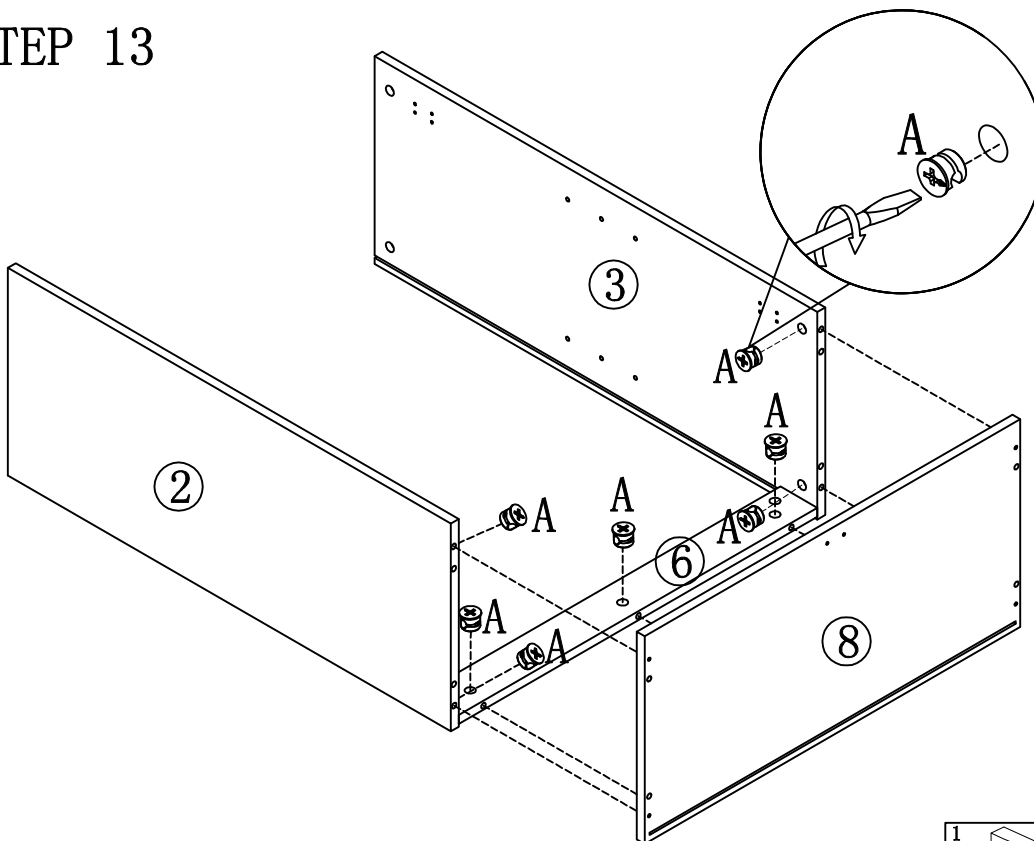

A \* 7PCS

# Assembly (EN) / Montageschritte (DE)



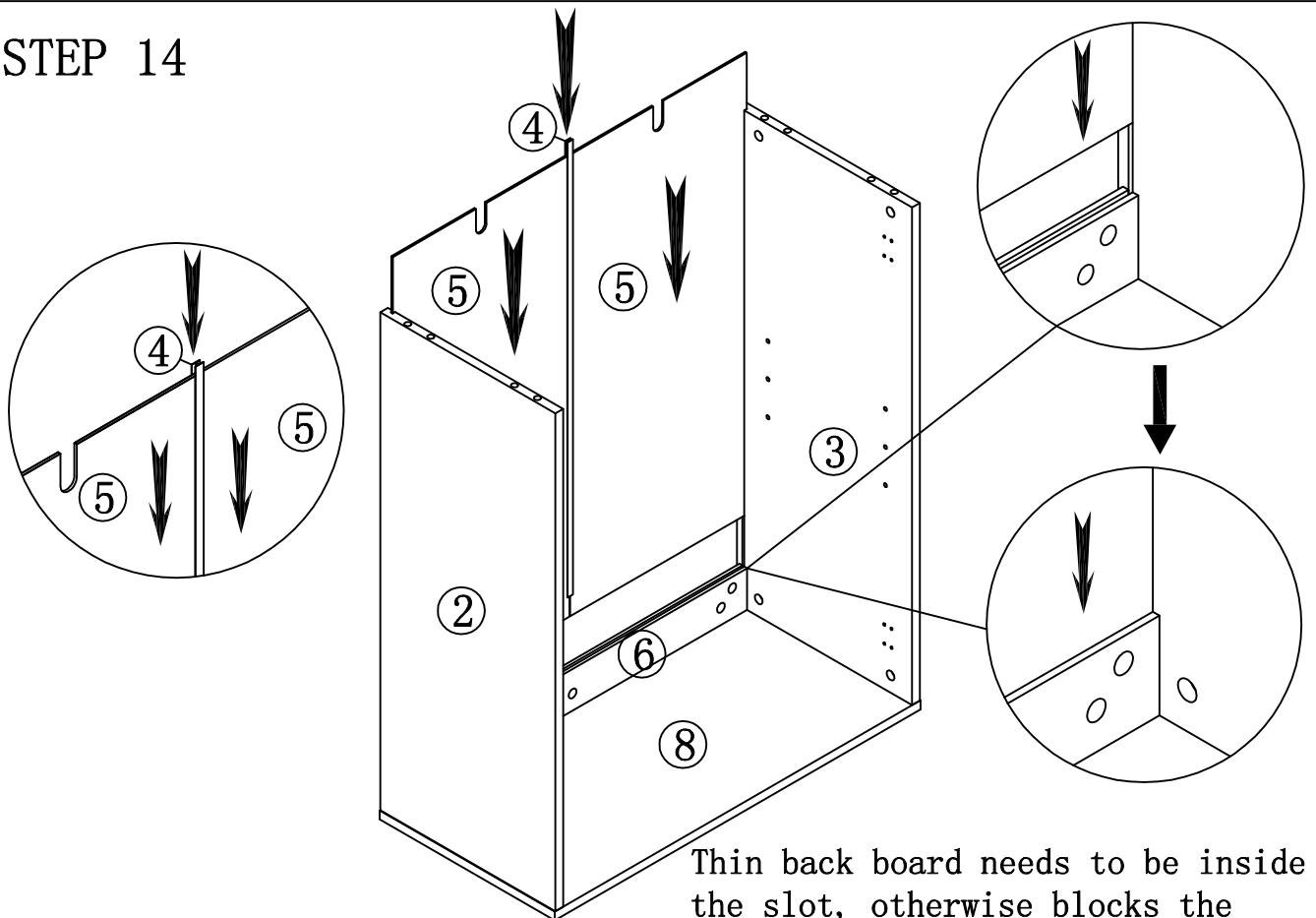

## STEP 14

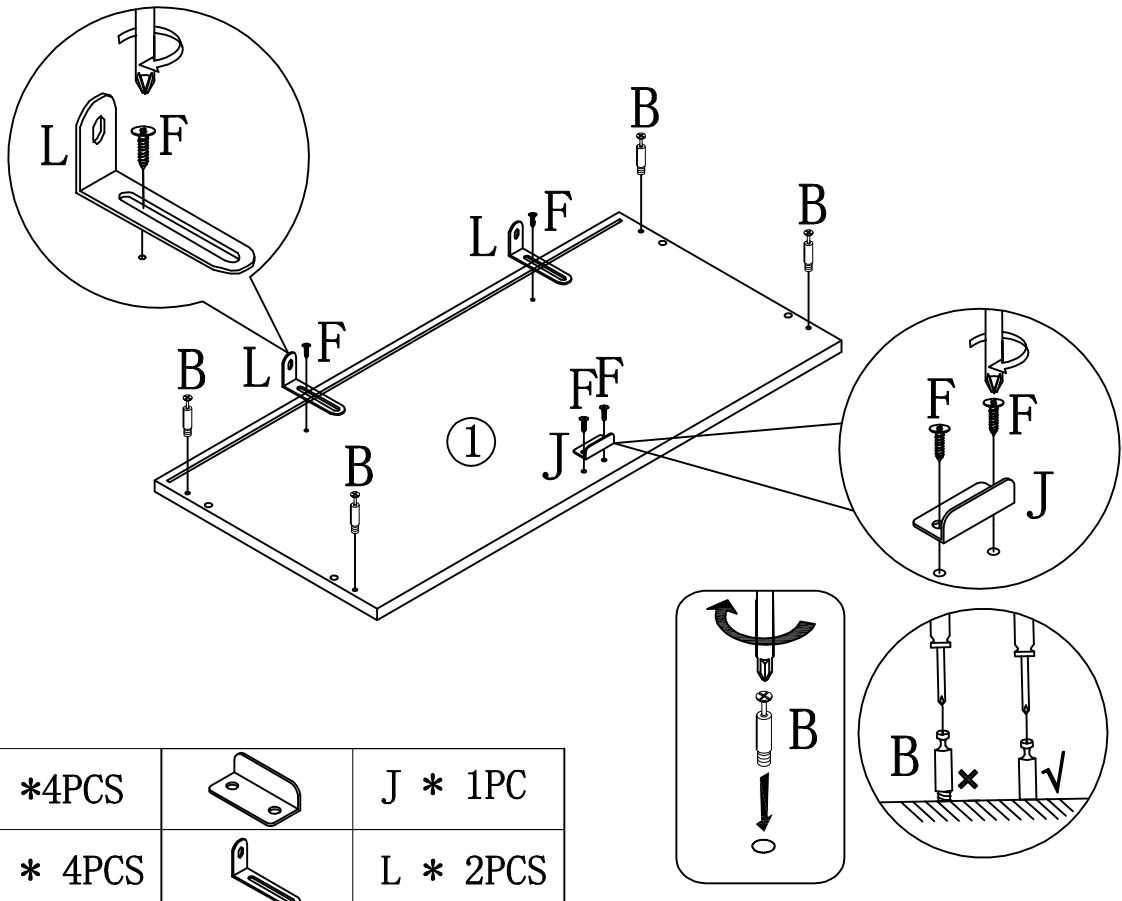

Thin back board needs to be inside the slot, otherwise blocks the opposite plate montage.

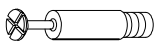
## STEP 15



	B * 4PCS		J * 1PC
	F * 4PCS		L * 2PCS

STEP 16

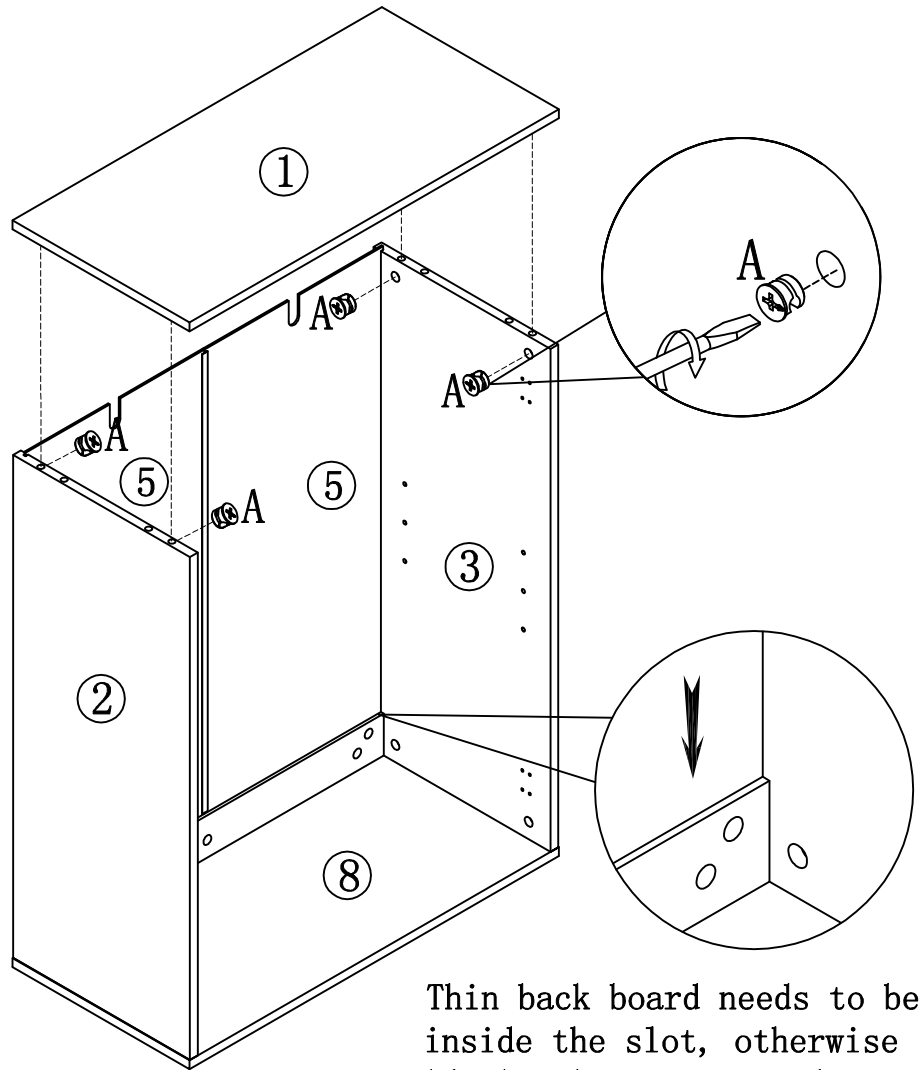

Thin back board needs to be inside the slot, otherwise blocks the opposite plate montage.





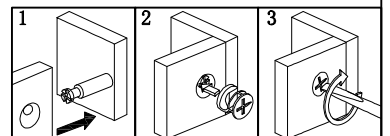

A \* 4PCS

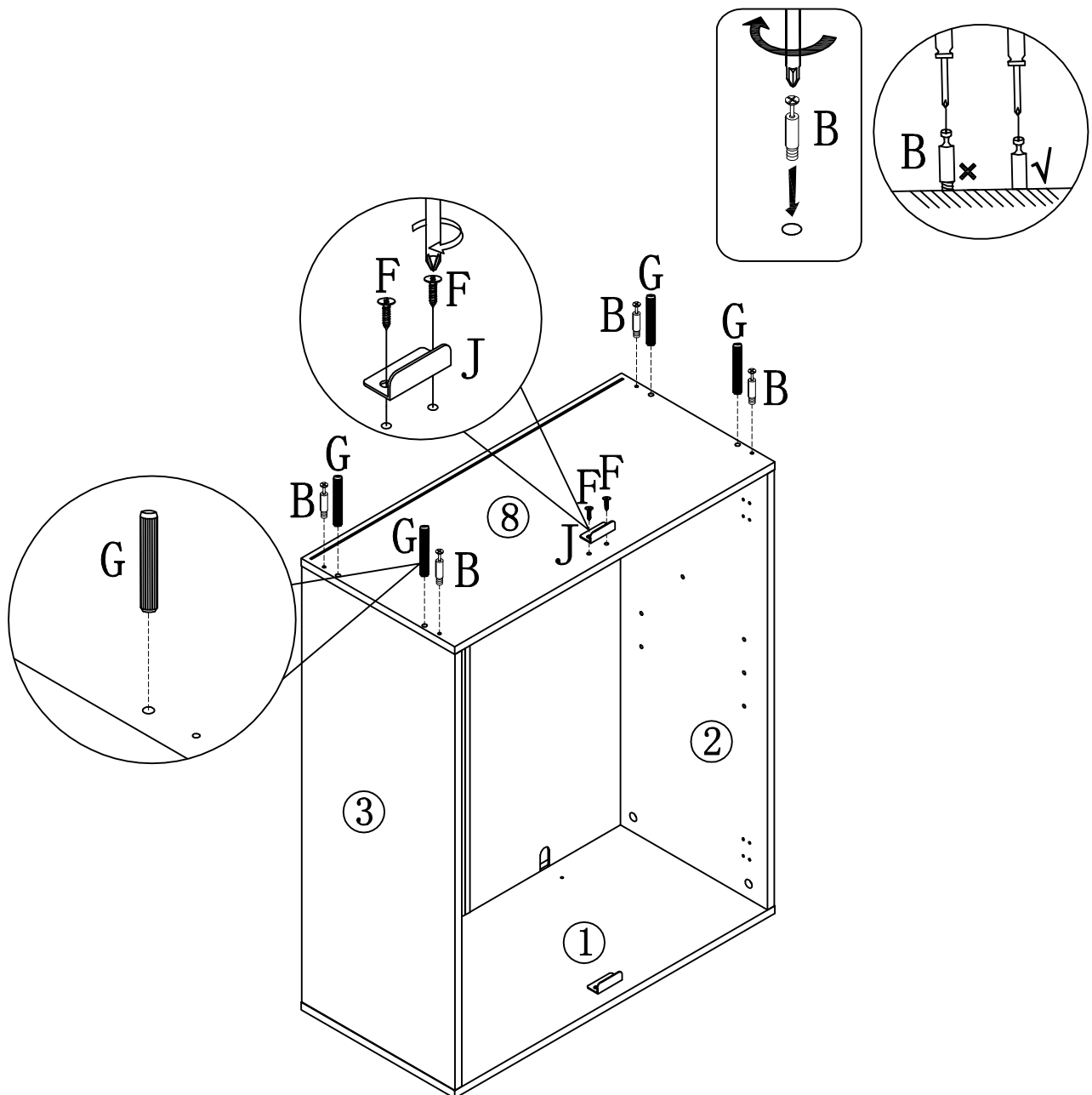

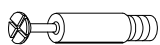
STEP 17



	B * 4PCS
	F * 2PCS
	G * 4PCS
	J * 1PC

# Assembly (EN) /Montageschritte (DE)

## STEP 18

Thin back board needs to be inside the slot, otherwise blocks the opposite plate montage.

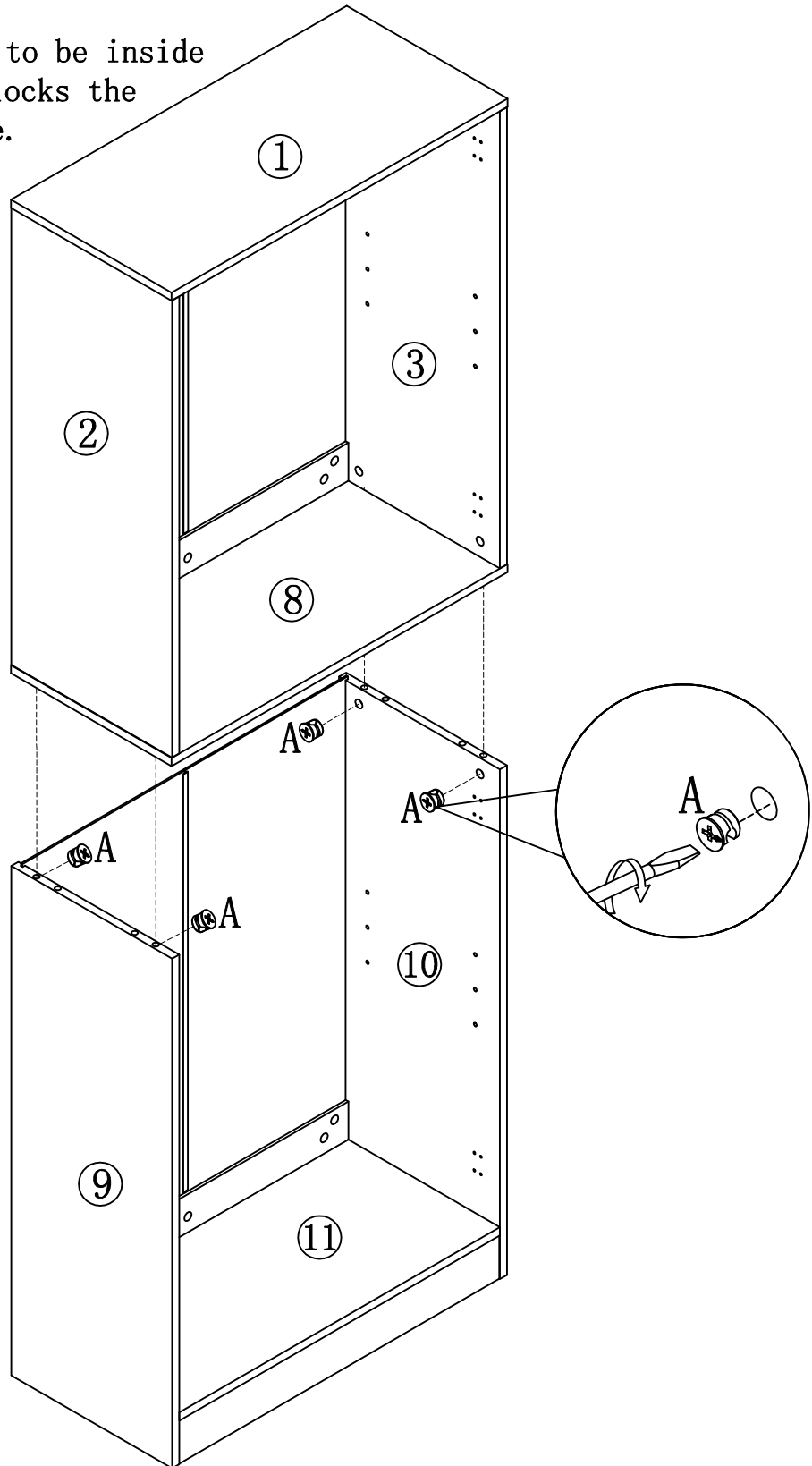

A \* 4PCS

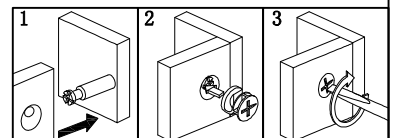

STEP 19

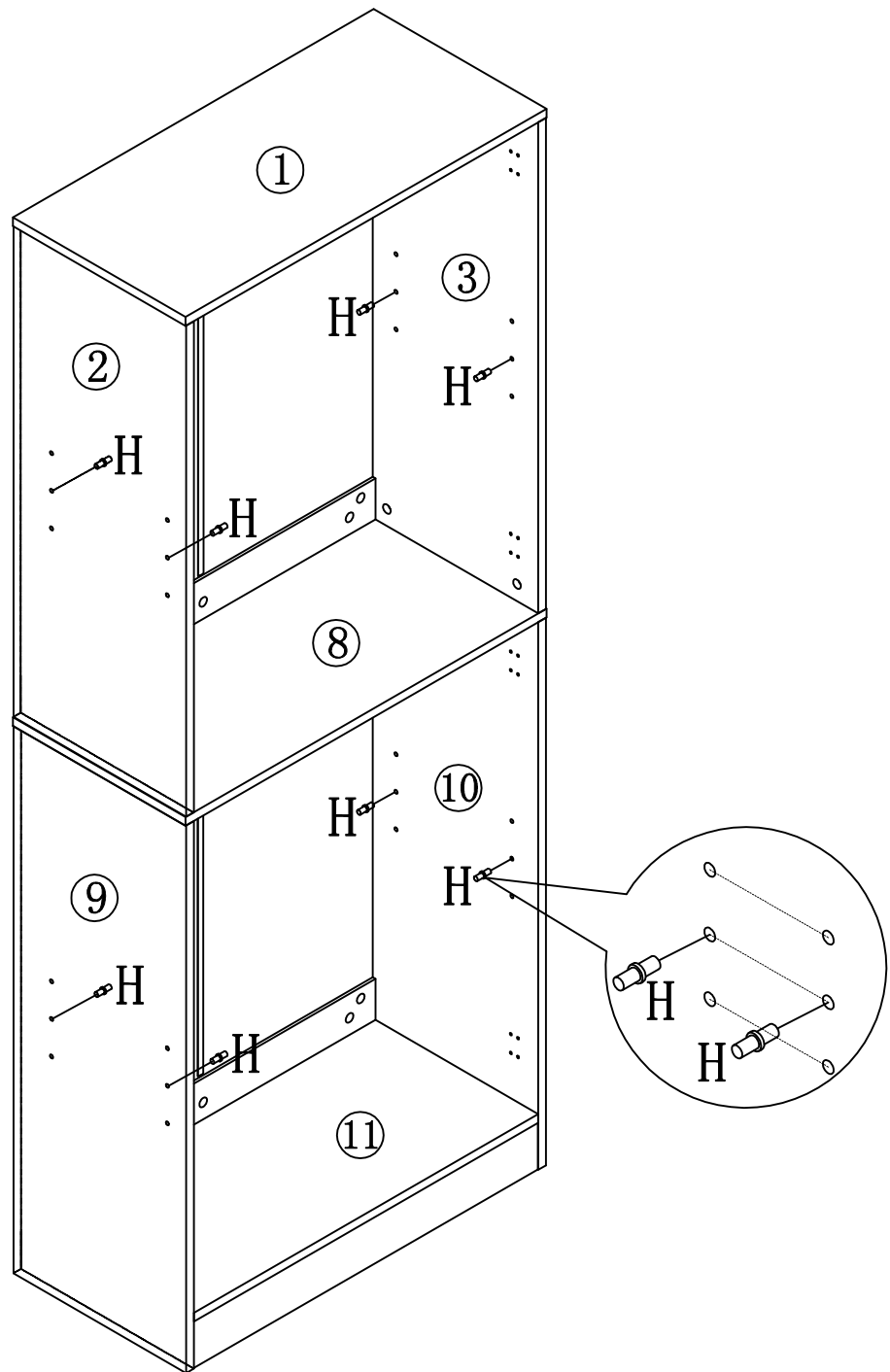

H \* 8PCS

STEP 20

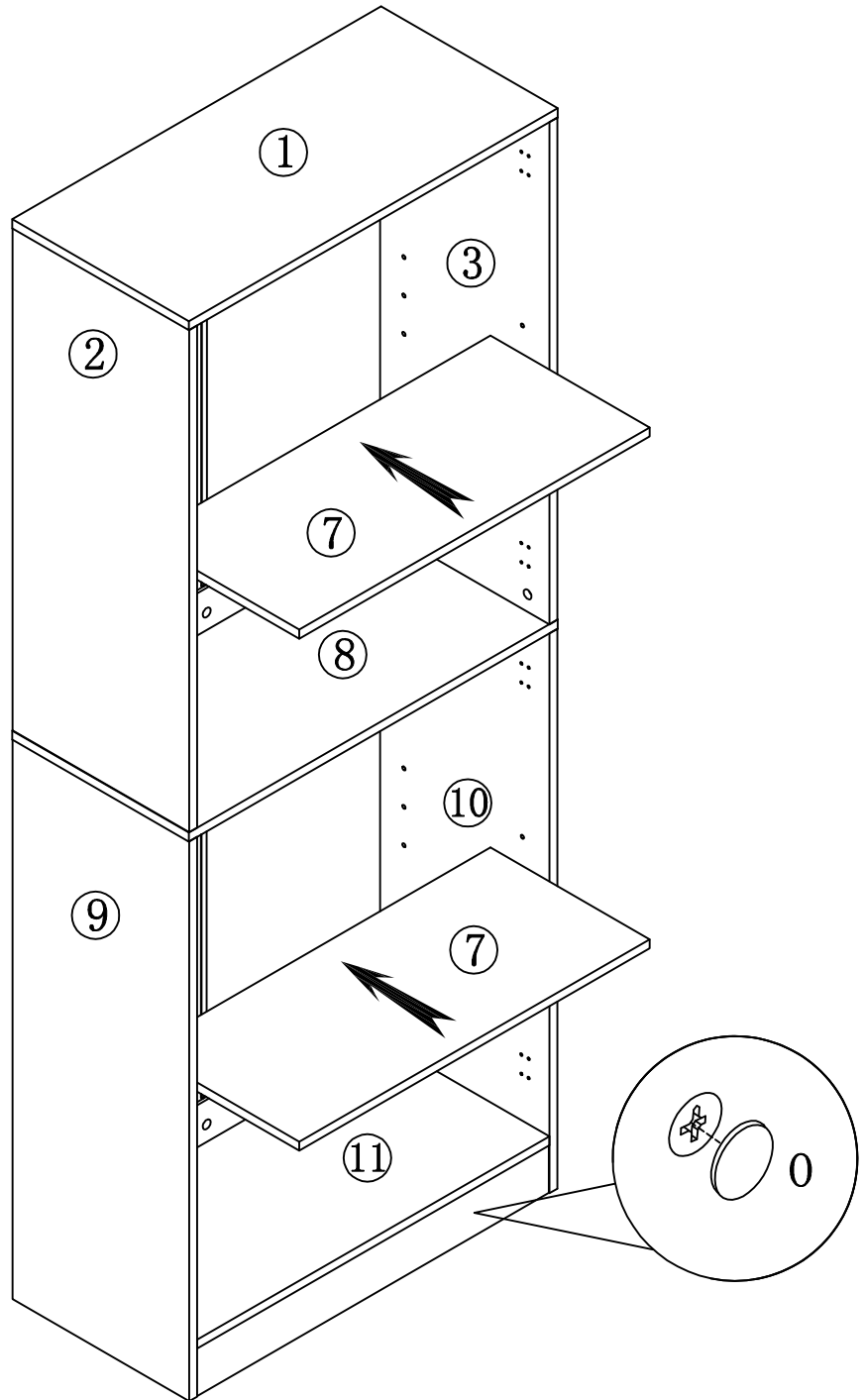



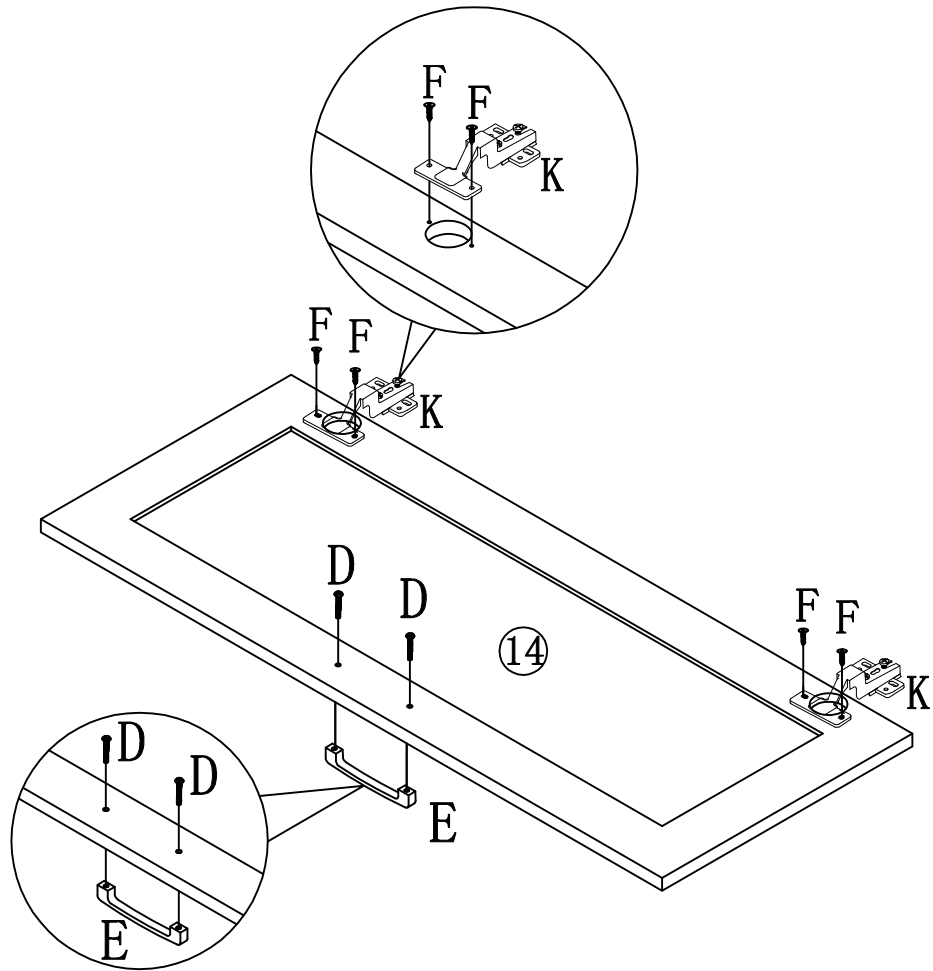

0 \*31PCS

STEP 21



x4

	D * 8PCS		F * 16PCS
	E * 4PCS		K * 8PCS

STEP 22

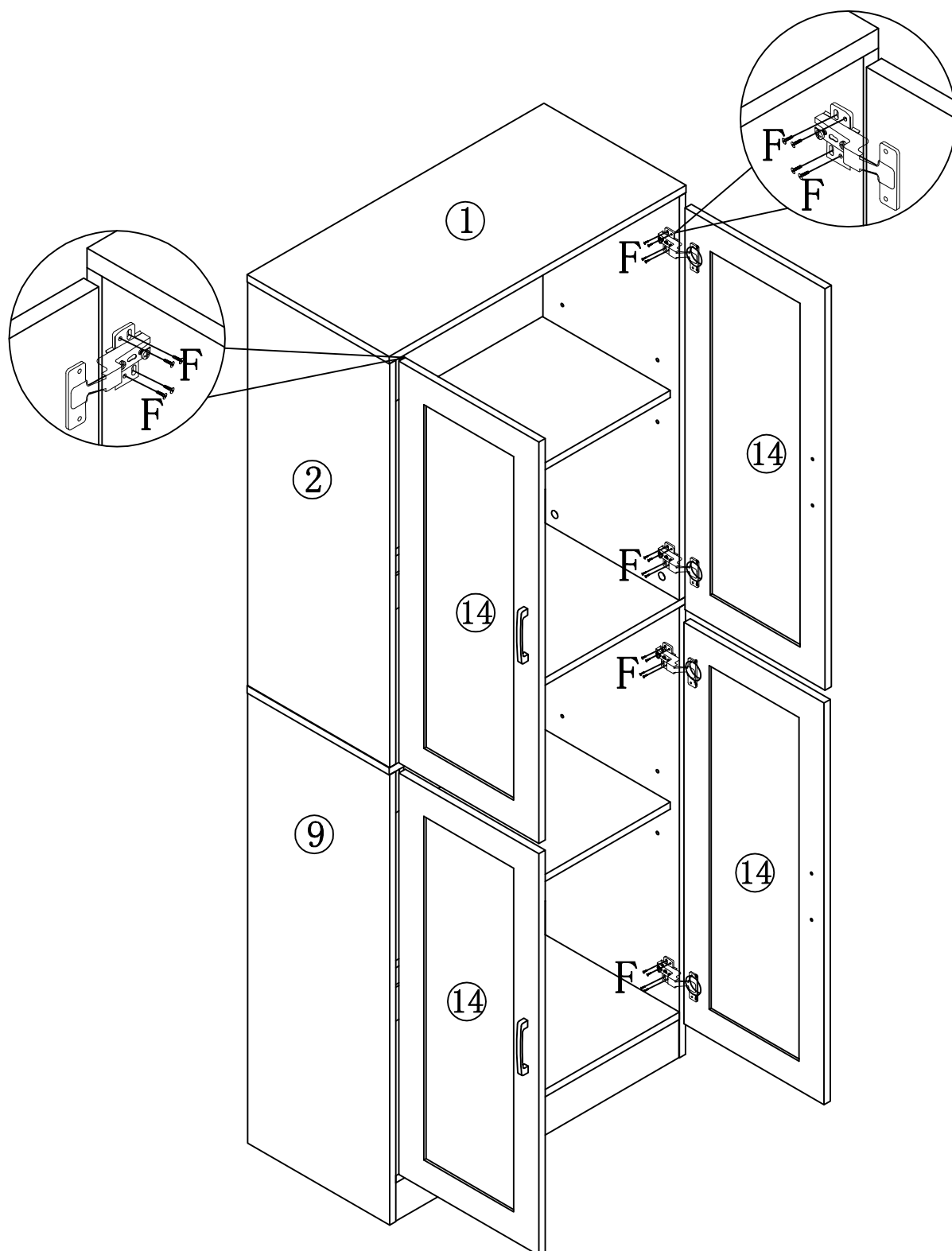

F \* 32PCS

# Assembly (EN) /Montageschritte (DE)

## STEP 23



NOTE : If you notice that the cabinet doors are not properly aligned, such as significant gaps or vertical or horizontal misalignment, please adhere to the following adjustment instructions.

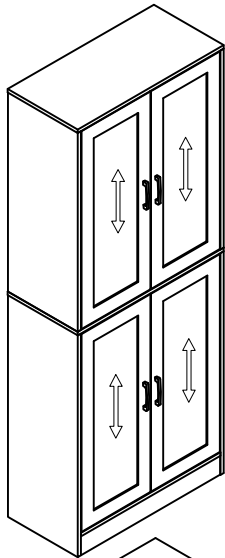

1

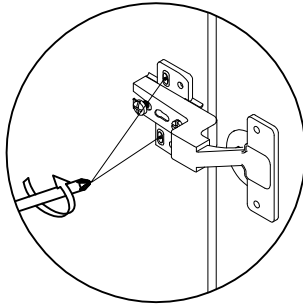

lose these 2 screws

2

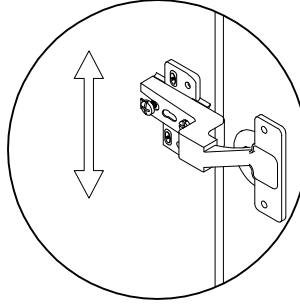

move hinge up/down

3

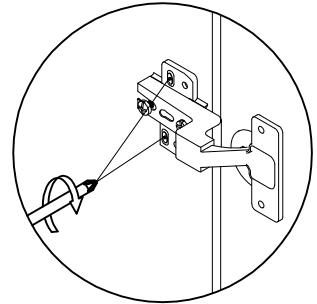

tighten these 2 screws again

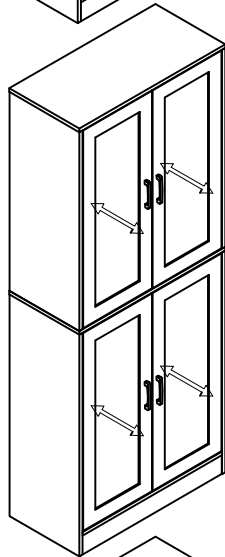

1

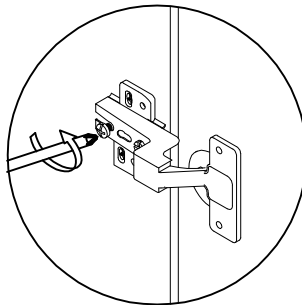

lose this screw

2

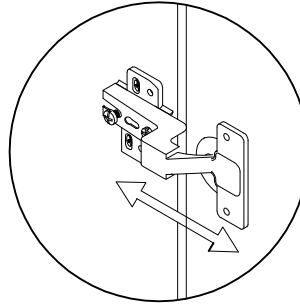

shift hinge in/out

3

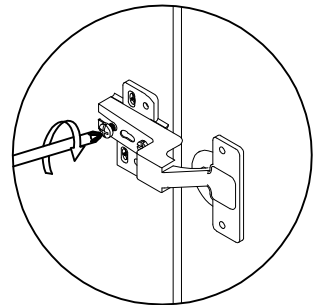

tighten this screw again

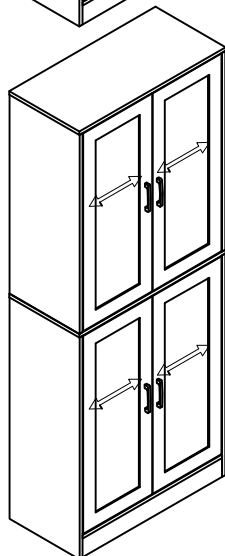

1

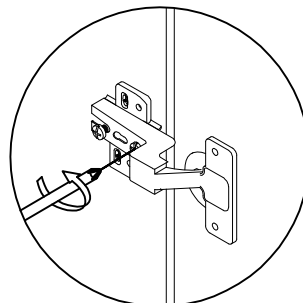

lose this screw would get hinge/door closer to side board

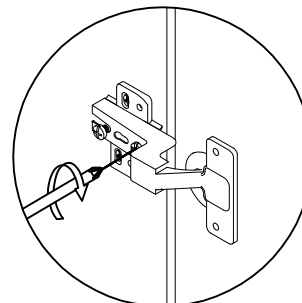

2

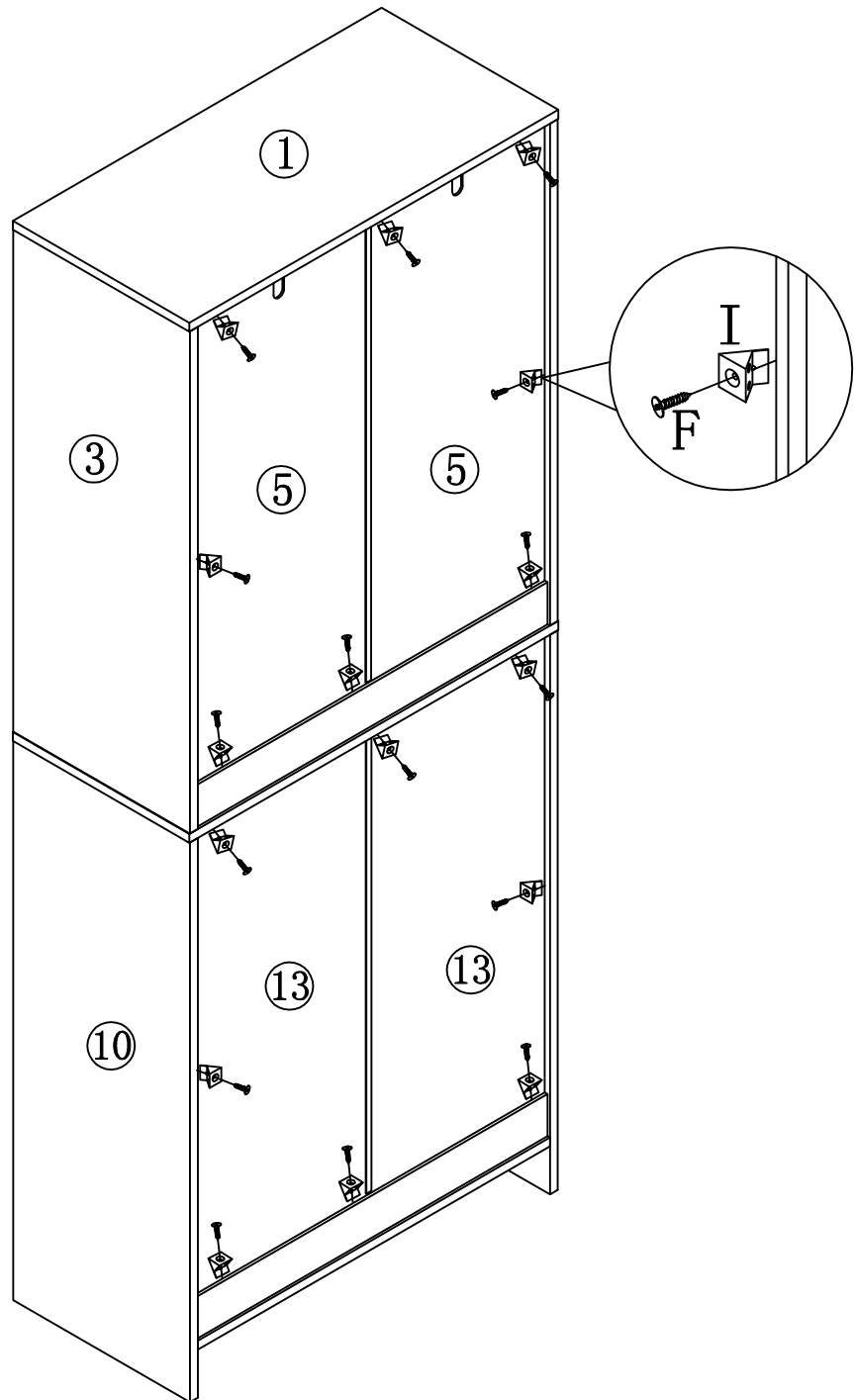

tighten this screw would get hinge/door away from side board

STEP 24



	F * 16PCS
	I * 16PCS

STEP 25

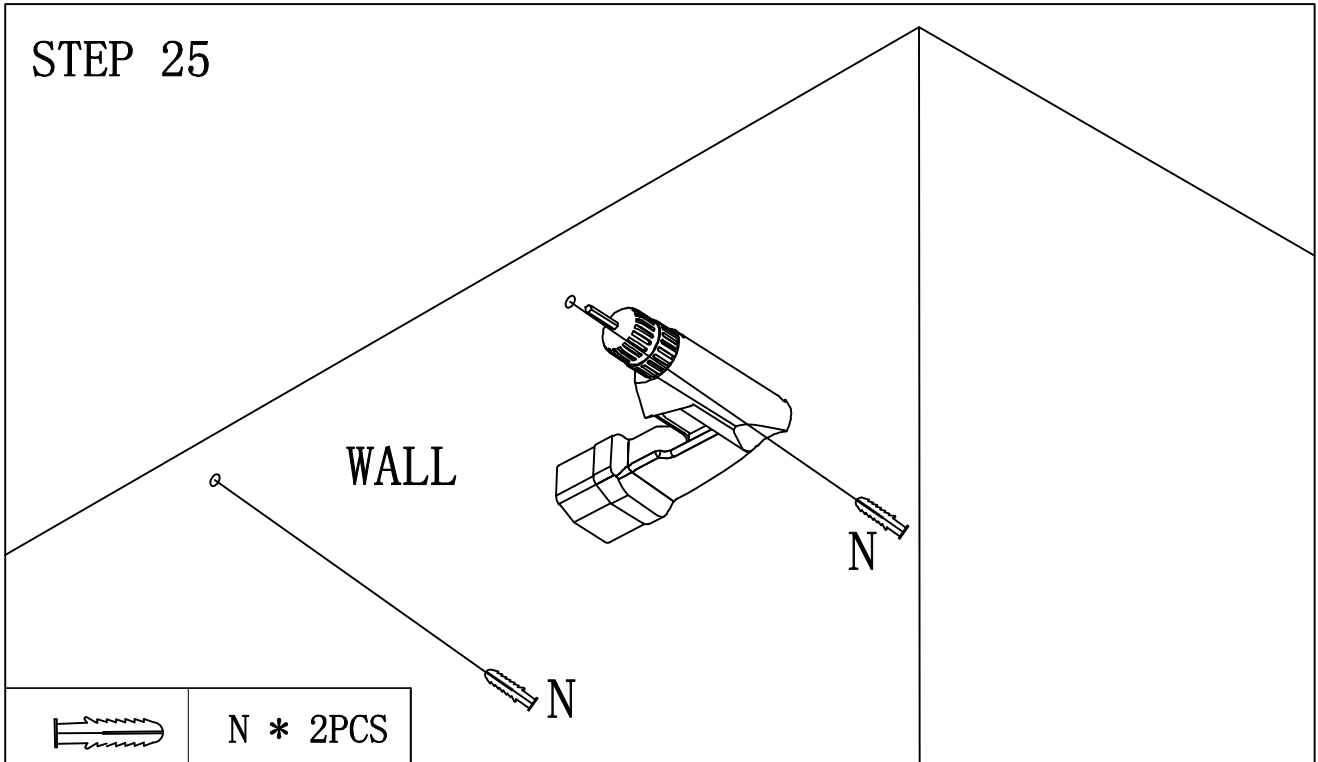

STEP 26

Note: Toppling preventer must be installed otherwise there is a risk of tipping.

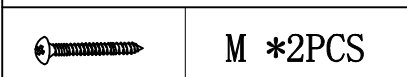
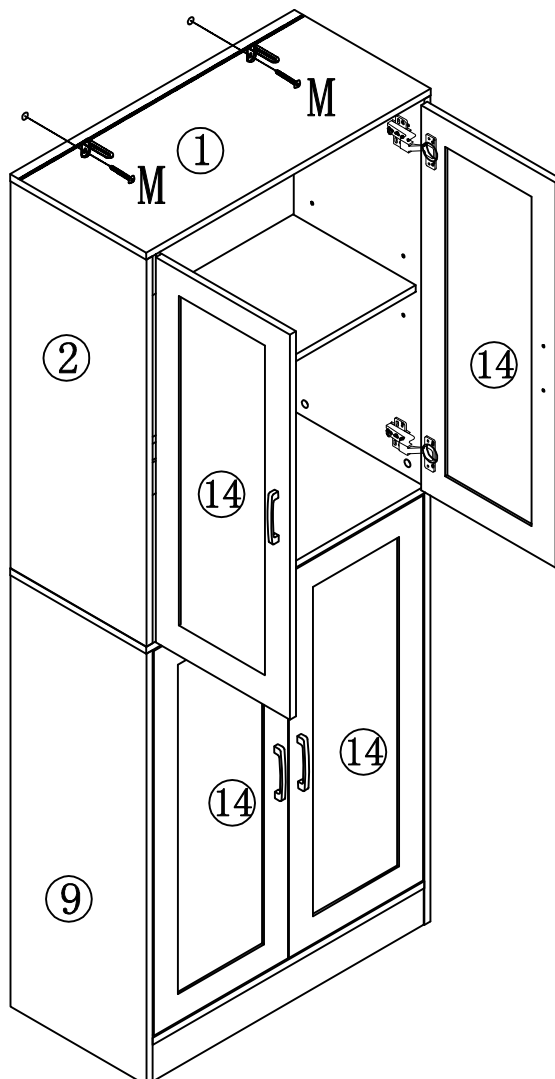
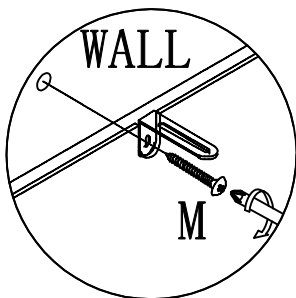

STEP 27

