

JY9937BS01

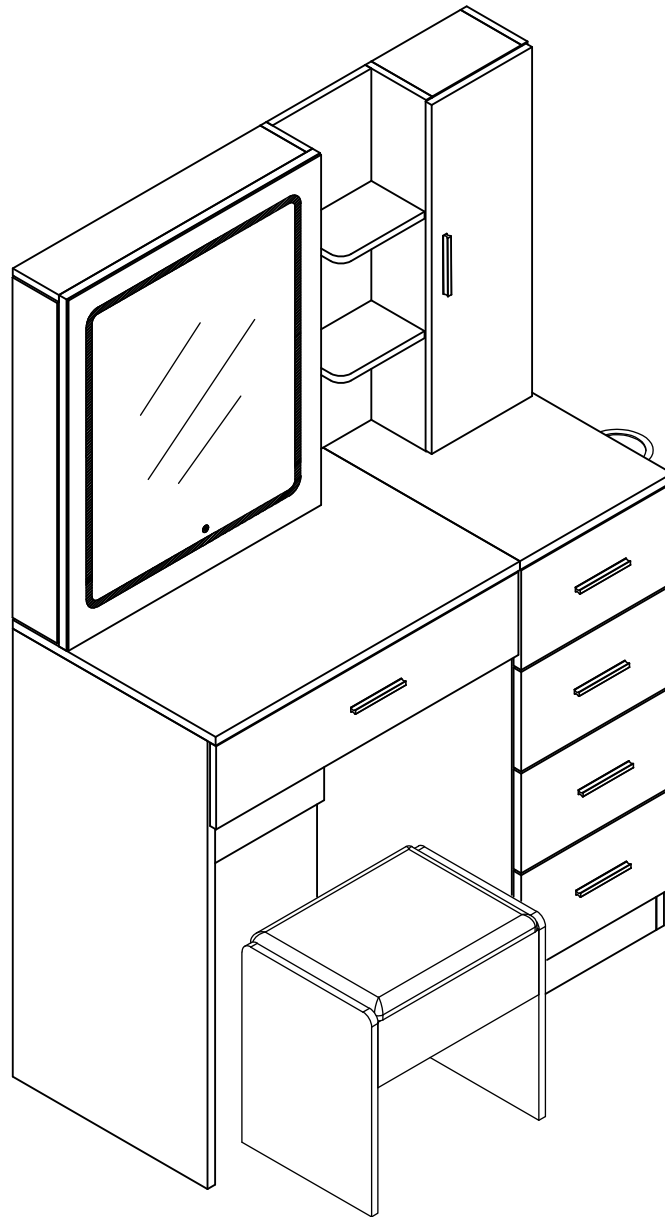

As this item contains many parts, please read the installation instruction carefully before installation . Please use tools properly and carefully. If you have any questions about the product and installation, please contact us.

hosoteservice@gmail.com

Our professional after-sales team will serve you online all day.

Before You Start

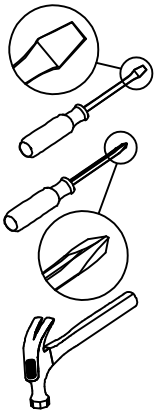

- ✓ Read through each step carefully and follow the proper order
- ✓ Separate and count all your parts and hardware
- ✓ Give yourself enough room for the assembly process
- ✓ Have the following tools: Flat Head Screwdriver, #2 Phillips Head Screwdriver and Hammer
- ✓ Caution: If using a power drill or power screwdriver for screwing, please be aware of to slow down and stop when screw is tight. Failure to do so may result in stripping the screw. Assembly speed can be increased by using electric screwdriver!

Helpful Hints

PEOPLE NEEDED FOR ASSEMBLY: 1-2

- Open your item in the area you plan to keep it to avoid excessive heavy lifting.



- Identify, sort and count the parts before attempting assembly.

- Compression dowels are lightly tapped in with a hammer.



- Slides are labeled with an R (right) and L (left) for proper placement.



- Make sure to always face the point on the top of the Cam Lock towards the outer edge.

- If there is a back panel in the package, please install it to make sure your unit is complete and sturdy.



- Please fix all the screws provided for the back panel which can enhance product stability. If it is difficult to fix it when tightening, it can be fixed with the help of a hammer and then tightened.



- Do NOT use harsh chemicals or abrasive cleaners on this item.



- Never push, pull, or drag your furniture.

Board Identification

Not actual size

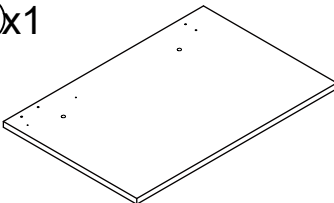
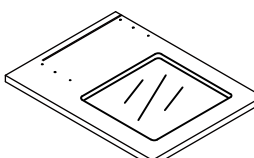
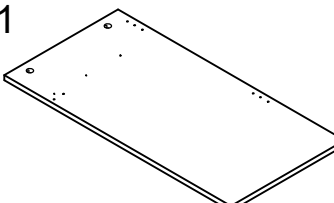
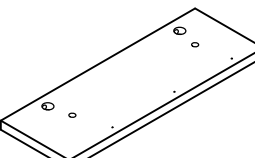
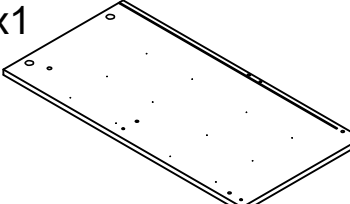
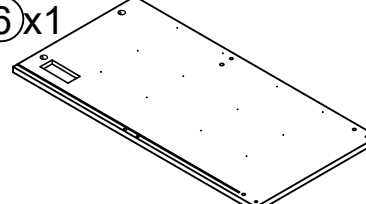
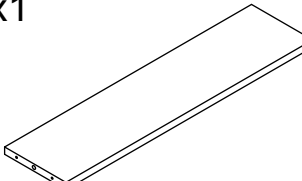
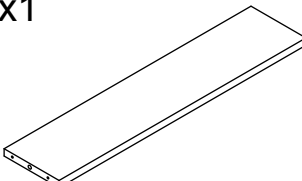
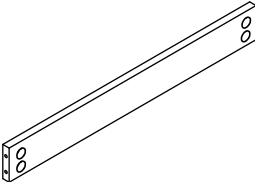
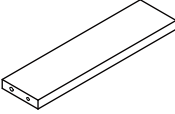
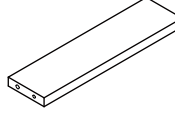
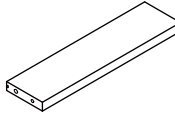
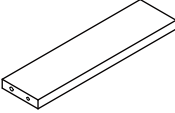
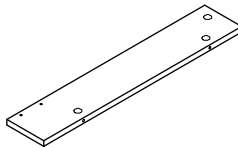
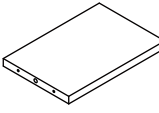
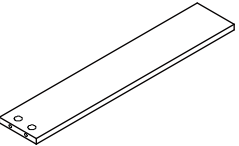
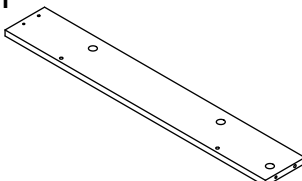
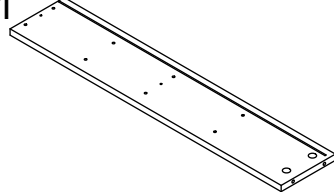
<p>①x1</p> 	<p>②x1</p> 	<p>③x1</p> 
<p>Panel</p>	<p>Panel</p>	<p>Lower left panel</p>
<p>④x1</p> 	<p>⑤x1</p> 	<p>⑥x1</p> 
<p>Middle Partition</p>	<p>Lower middle side panel</p>	<p>Lower right panel</p>
<p>⑦x1</p> 	<p>⑧x1</p> 	<p>⑨x1</p> 
<p>Lower left rear brace</p>	<p>Lower left rear brace</p>	<p>Lower left front brace</p>
<p>⑩x1</p> 	<p>⑪x1</p> 	<p>⑫x1</p> 
<p>Lower right rear brace</p>	<p>Lower right rear brace</p>	<p>Lower right rear brace</p>
<p>⑬x2</p> 	<p>⑭x1</p> 	<p>⑮x1</p> 
<p>Lower right rear brace</p>	<p>Upper left laminate</p>	<p>Upper right roof panel</p>
<p>⑯x1</p> 	<p>⑰x1</p> 	<p>⑱x1</p> 
<p>Rear support plate</p>	<p>Rear support plate</p>	<p>Upper right left panel</p>

Board Identification

Not actual size

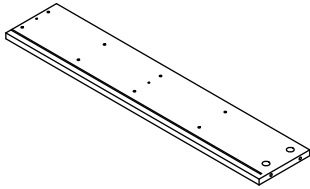
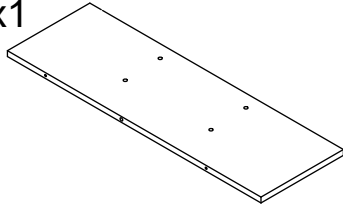
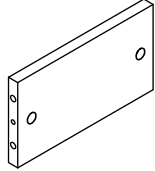
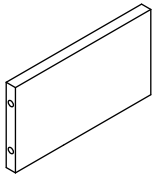
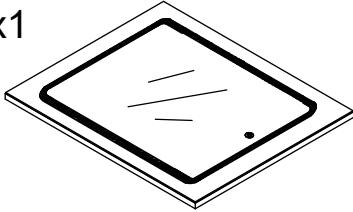
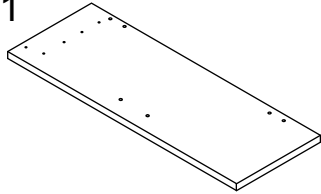
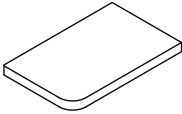
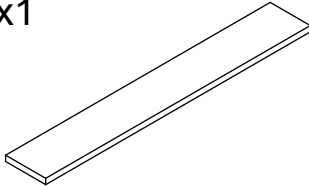
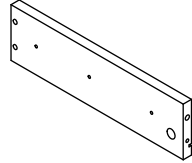
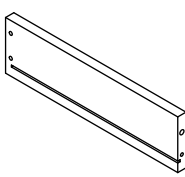
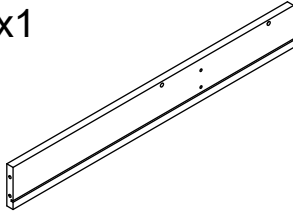
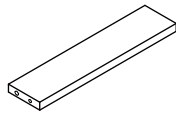
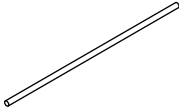
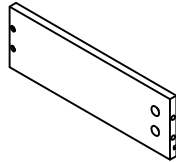
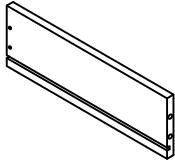
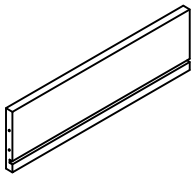
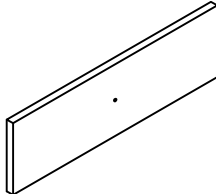
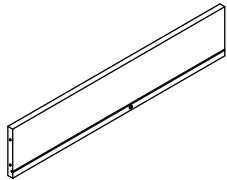
①9 x1 	②0 x1 	②1 x1 
Right upper right panel	Rear support plate	Upper right board
②2 x2 	②3 x1 	②4 x1 
Upper right board	Mirror back plate	Righth upper door panel
②5 x2 	②6 x1 	②7 x1 
Upper right board	Dresser panels	Drawer left side plate
②8 x1 	②9 x1 	③0 x1 
Drawer right side plate	Rear panel of drawer	Upper cabinet support plate
③1 x2 	③2 x5 	③3 x5 
Bars	Drawer left side plate	Drawer right side plate
③4 x4 	③5 x4 	③6 x1 
Rear panel of drawer	Drawer panel	Rear panel of drawer

Board Identification

Not actual size

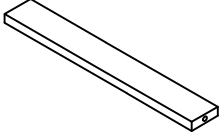
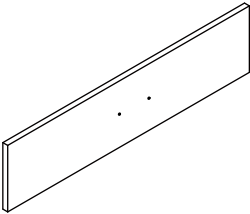
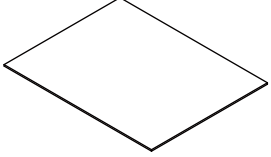
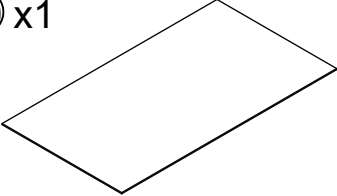
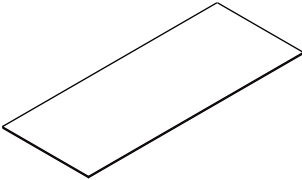
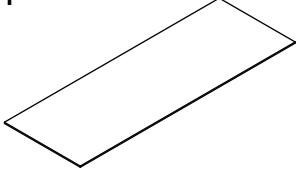
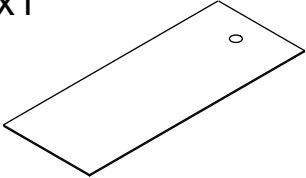
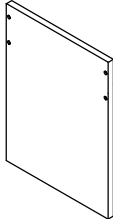
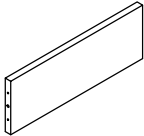
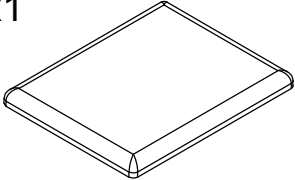
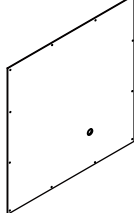
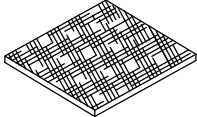
<p>③⑦ x1</p> 	<p>③⑧ x1</p> 	<p>③⑨ x4</p> 
<p>Drawer base plate strip</p>	<p>Drawer panel</p>	<p>Drawer base plate</p>
<p>④① x1</p> 	<p>④② x1</p> 	<p>④③ x1</p> 
<p>Drawer base plate</p>	<p>Backplane</p>	<p>Backplane</p>
<p>④④ x1</p> 	<p>④⑤ x2</p> 	<p>④⑥ x2</p> 
<p>Backplane</p>	<p>Stool side plate</p>	<p>Stool brace</p>
<p>④⑦ x1</p> 	<p>④⑧ x1</p> 	<p>④⑨ x1</p> 
<p>Stool surface</p>	<p>Backplane</p>	<p>Sponge</p>

Part List

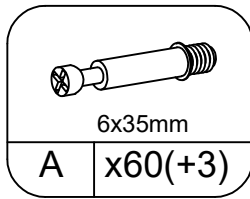

Cam Bolt

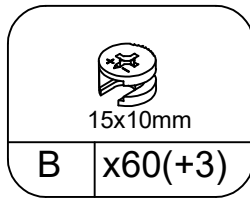

Cam Lock

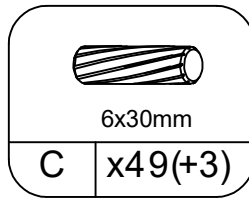

Dowel

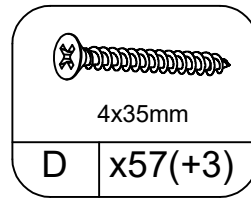

Screw

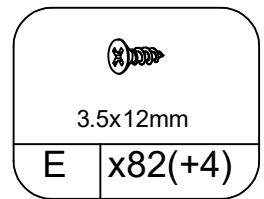

Screw

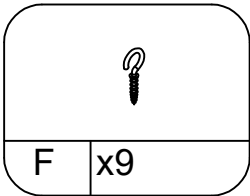

Hook

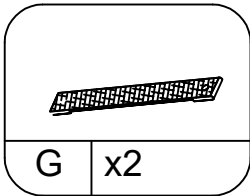

Anti-Fall Strip

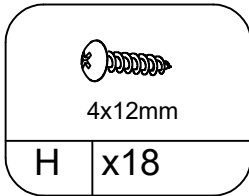

Screw

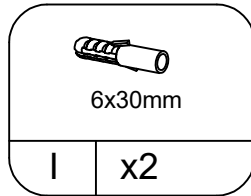

Plastic Expansion

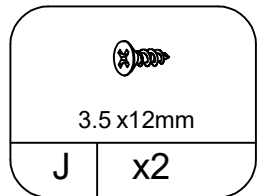

Screw

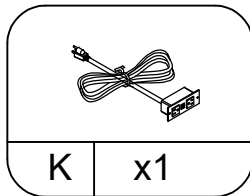

Electrical outlet

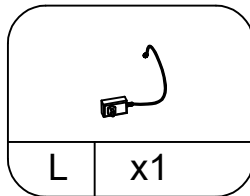

Plug

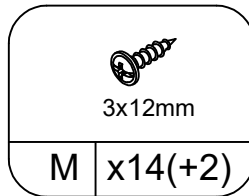

Screw

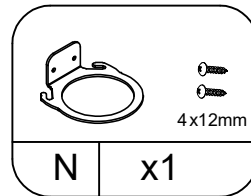

x1

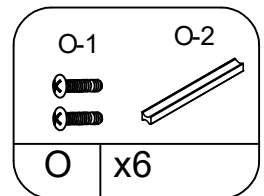

Handle screw and handle

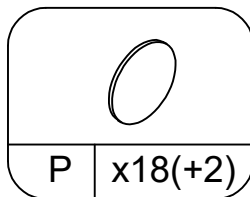

Hole sticker

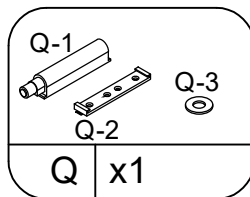

Elastomer

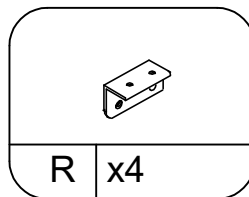

Iron angle code

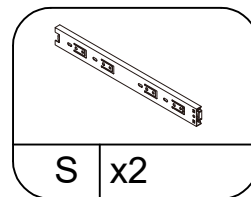

x2

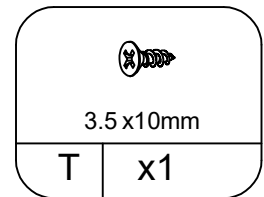

Screw

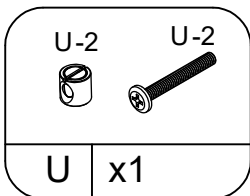

Hole sticker

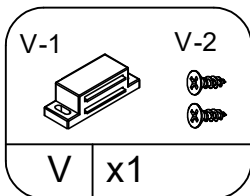

Elastomer

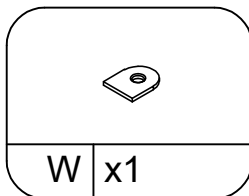

Iron angle code

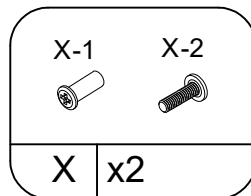

x2

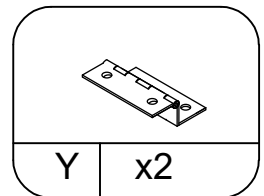

Screw

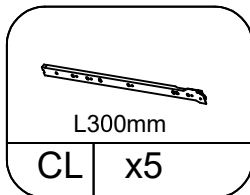

Sliding Track

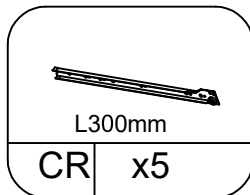

Sliding Track

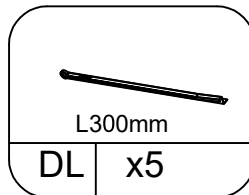

Sliding Track

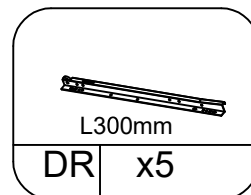

Sliding Track

Part List

Cam Lock Fastening System

Insert the cam bolt into the hole first, then insert the cam lock and lock it.

1

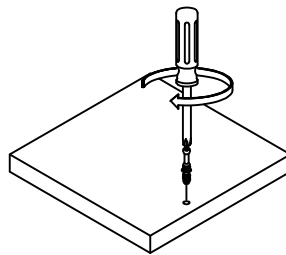

2

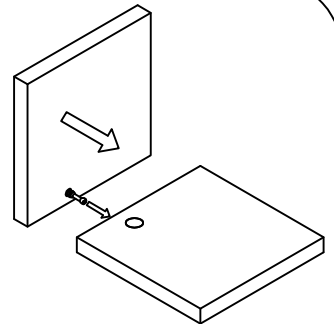

3

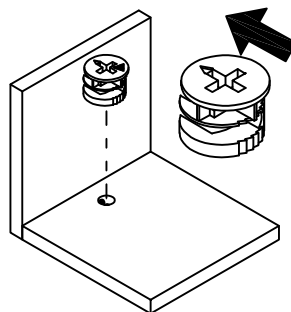

The opening must point toward the edge of the board

4

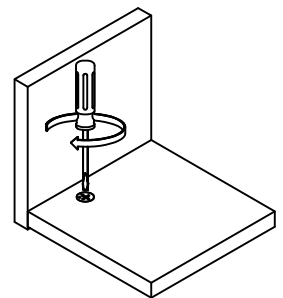

Board Identification

Not actual size

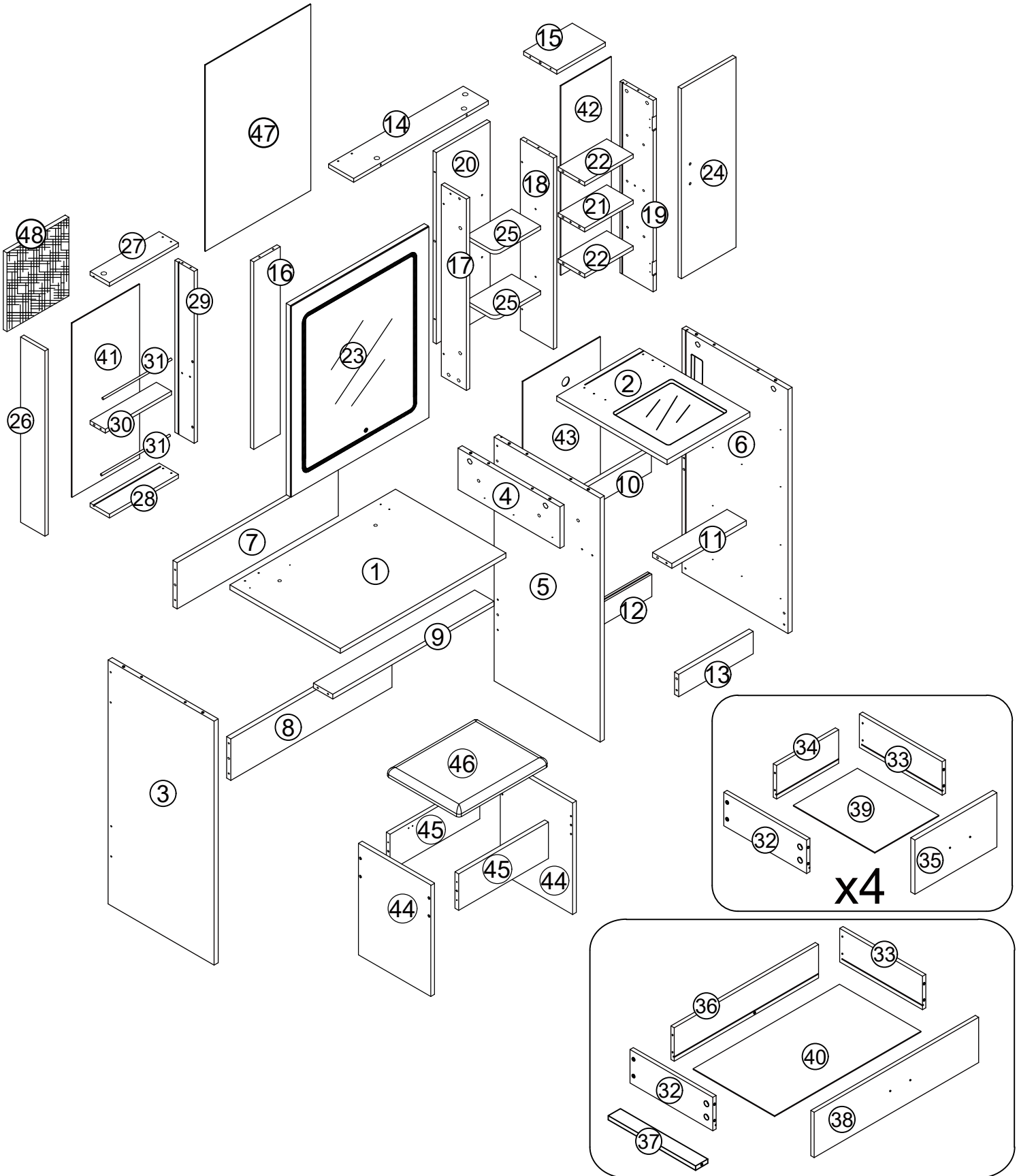

STEP 1

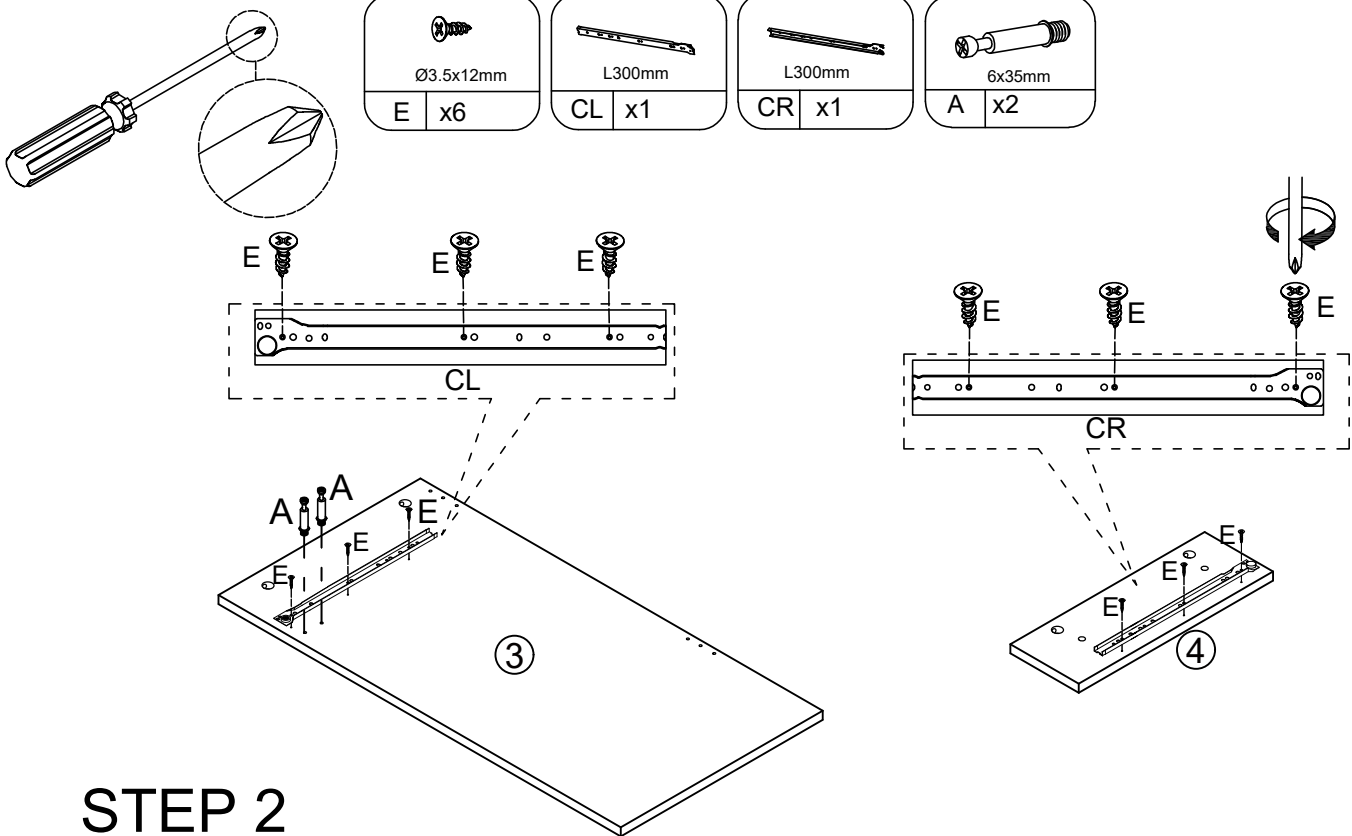

STEP 2

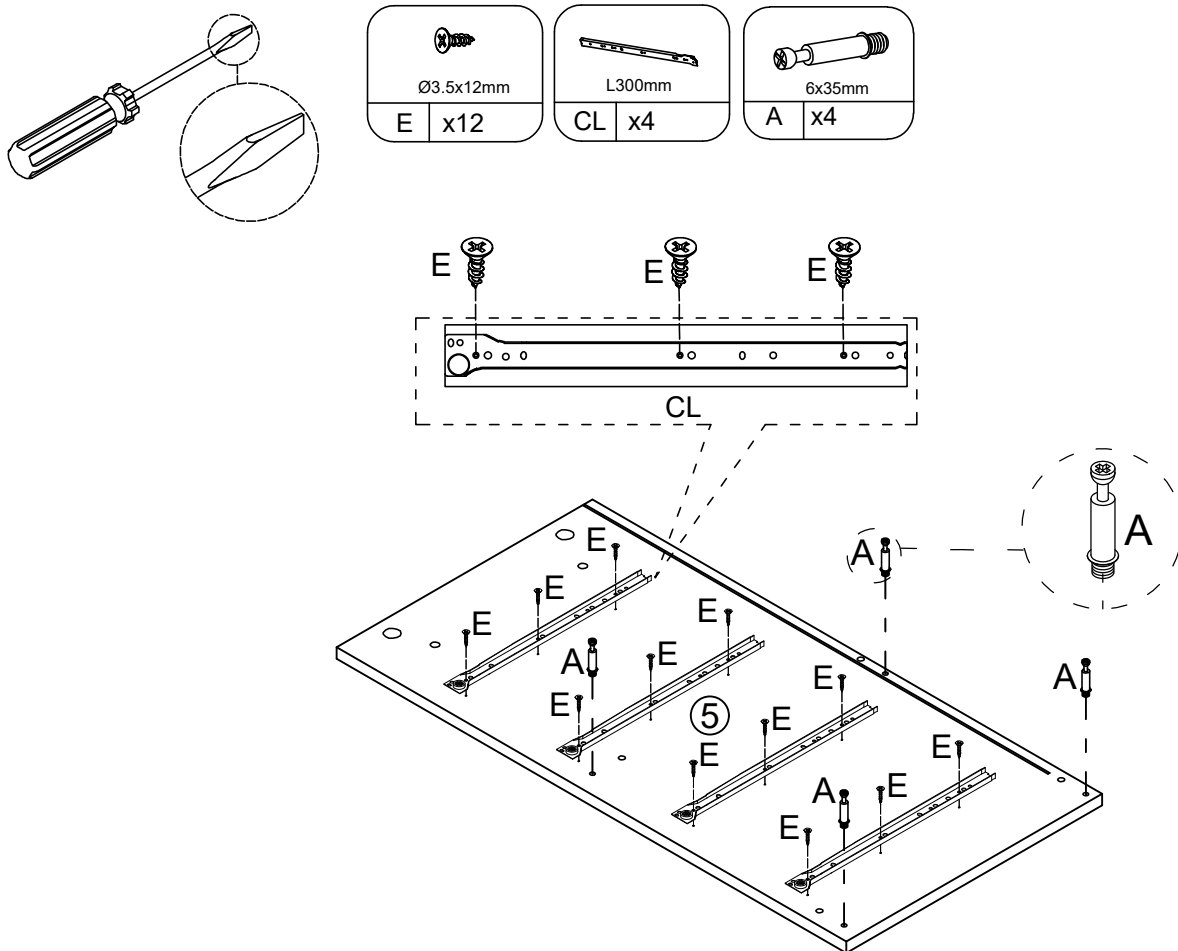

STEP 3

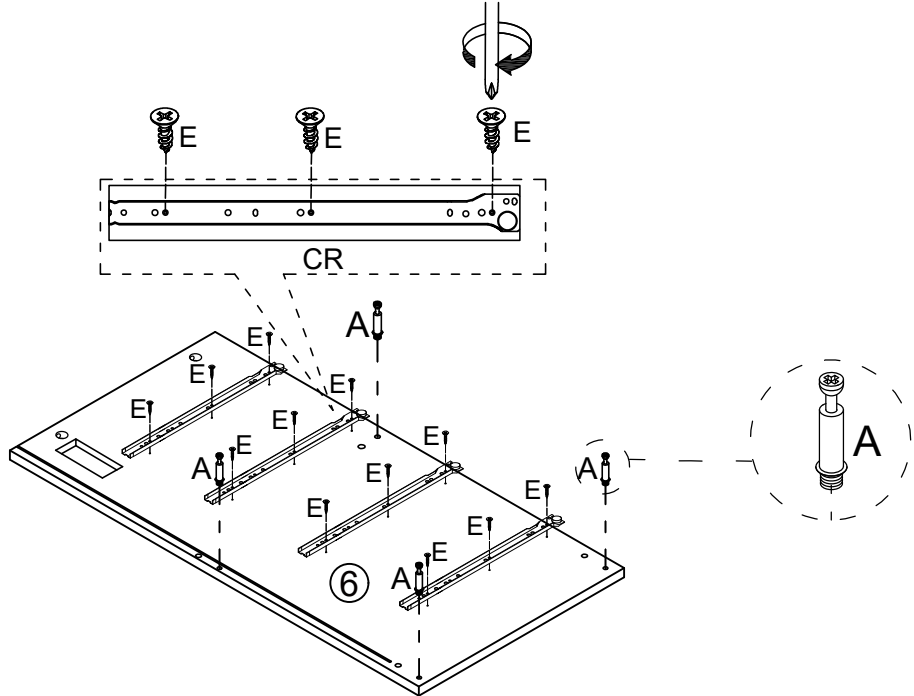
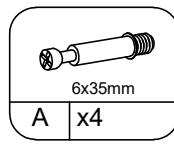
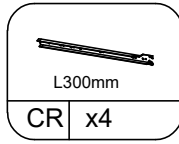
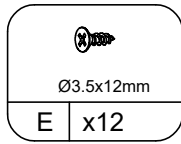
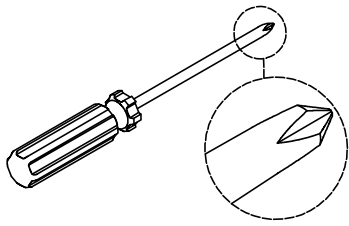

STEP 4

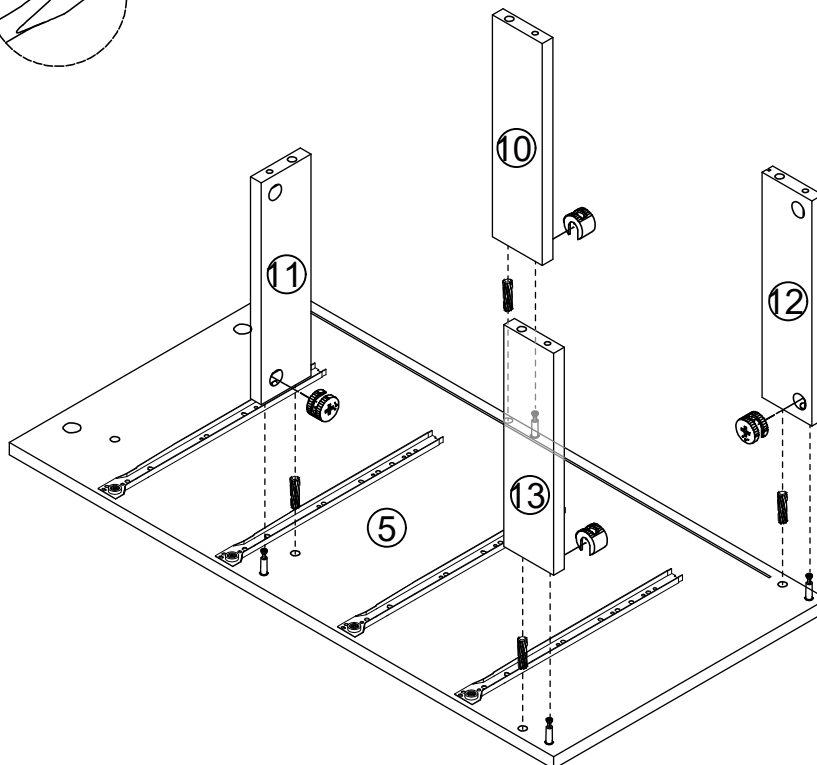
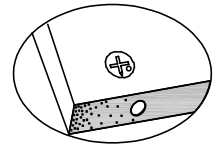
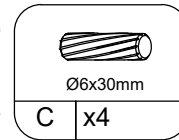
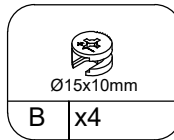
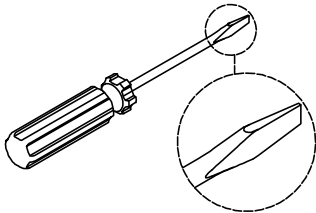

STEP 5

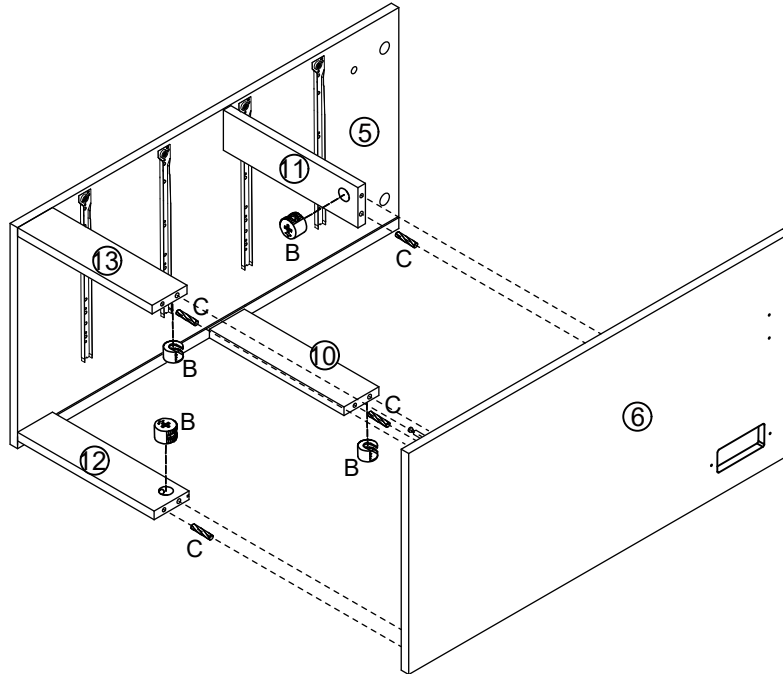
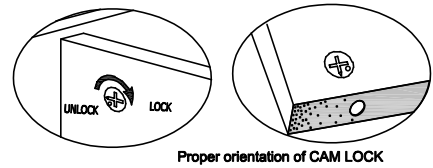
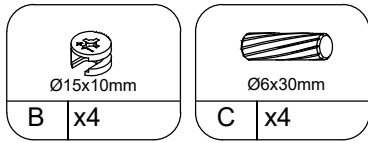
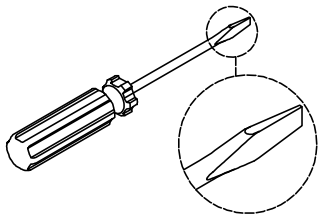

STEP 6

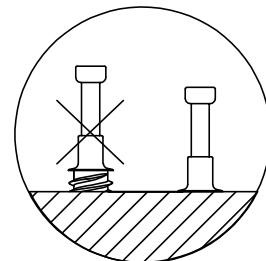
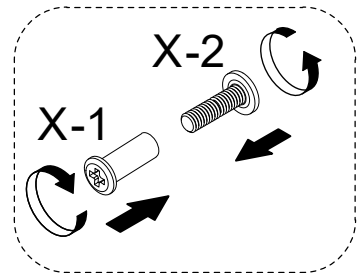
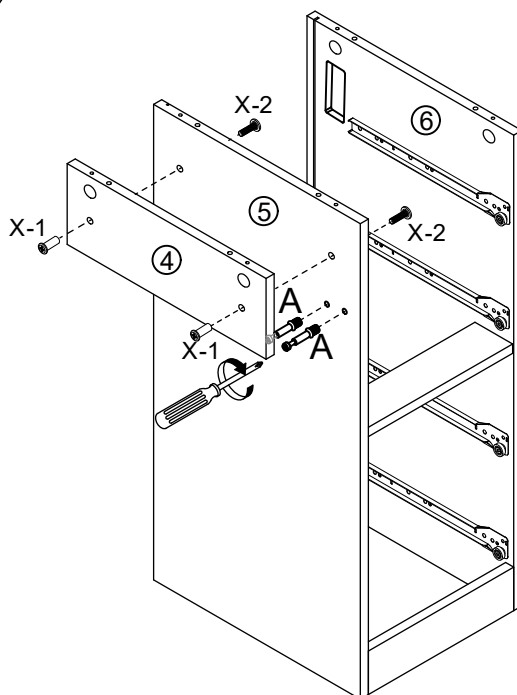
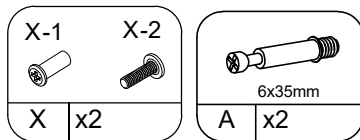
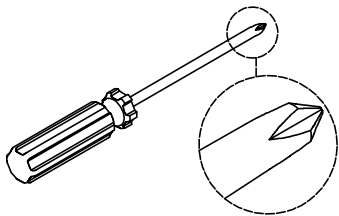

STEP 7

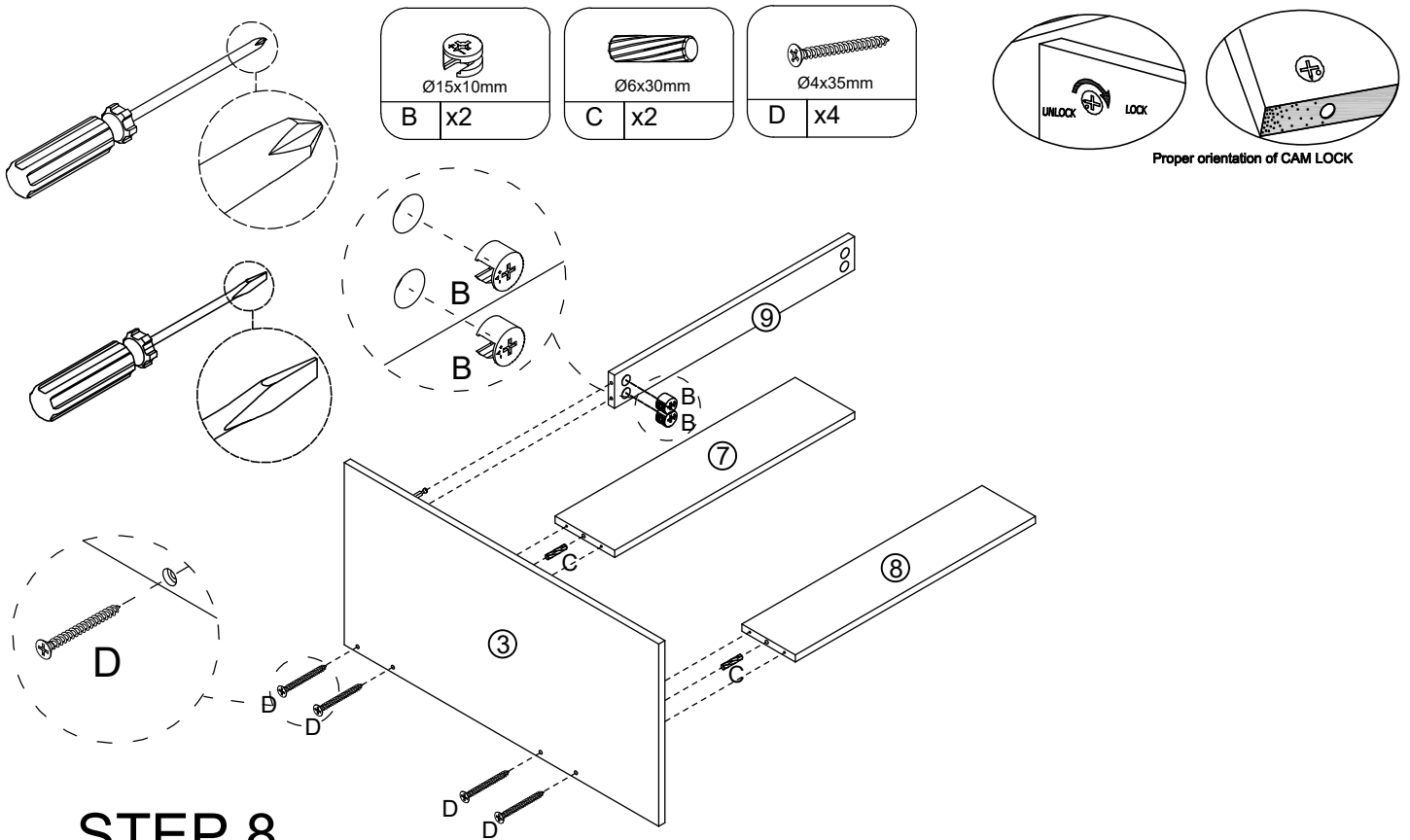

STEP 8

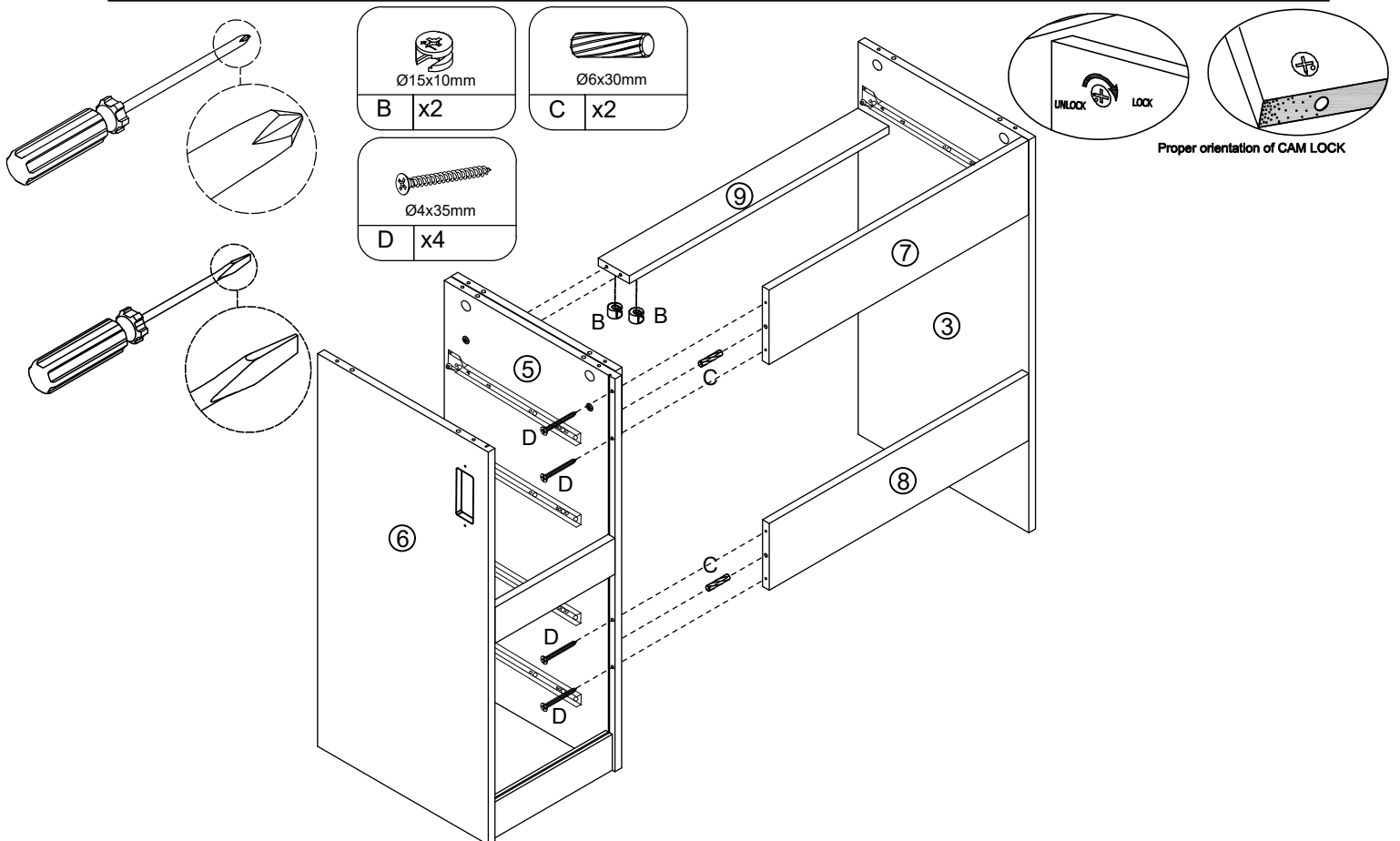

STEP 9

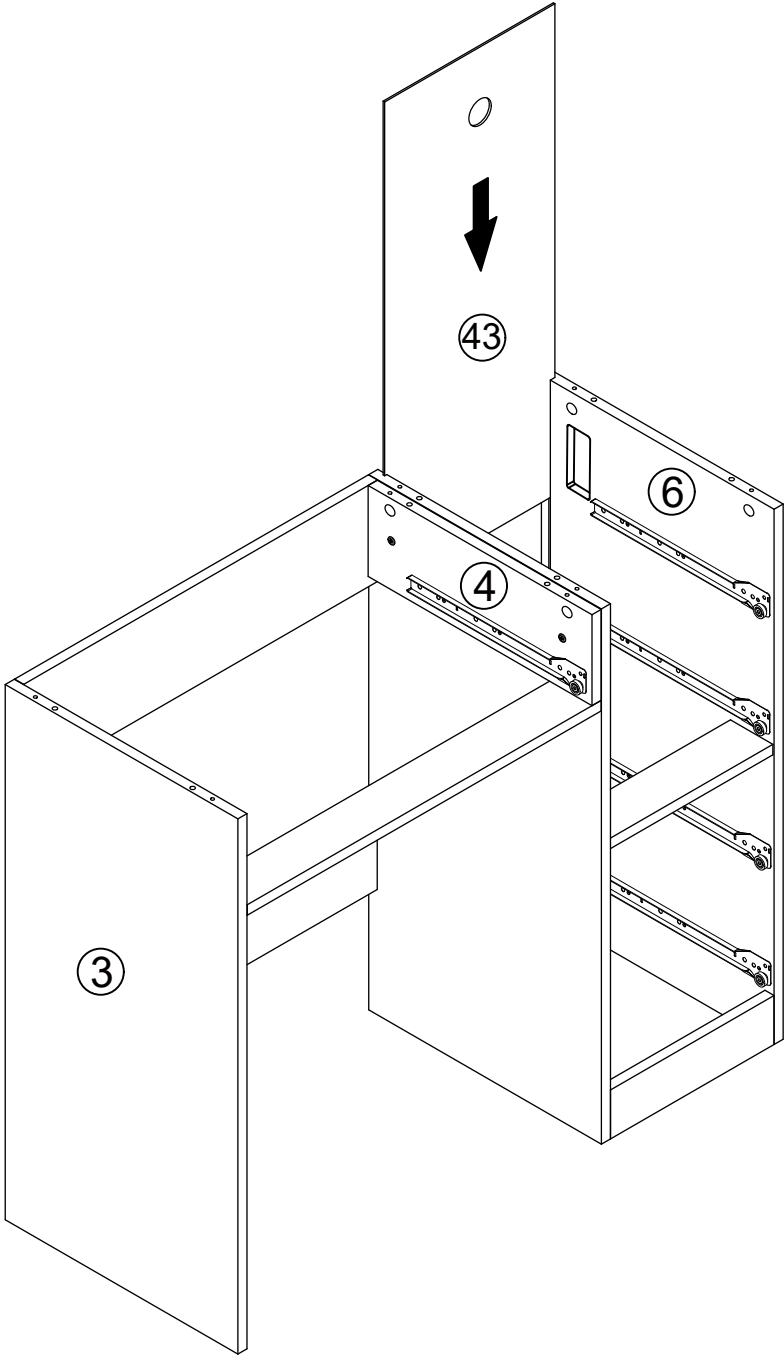

STEP 10

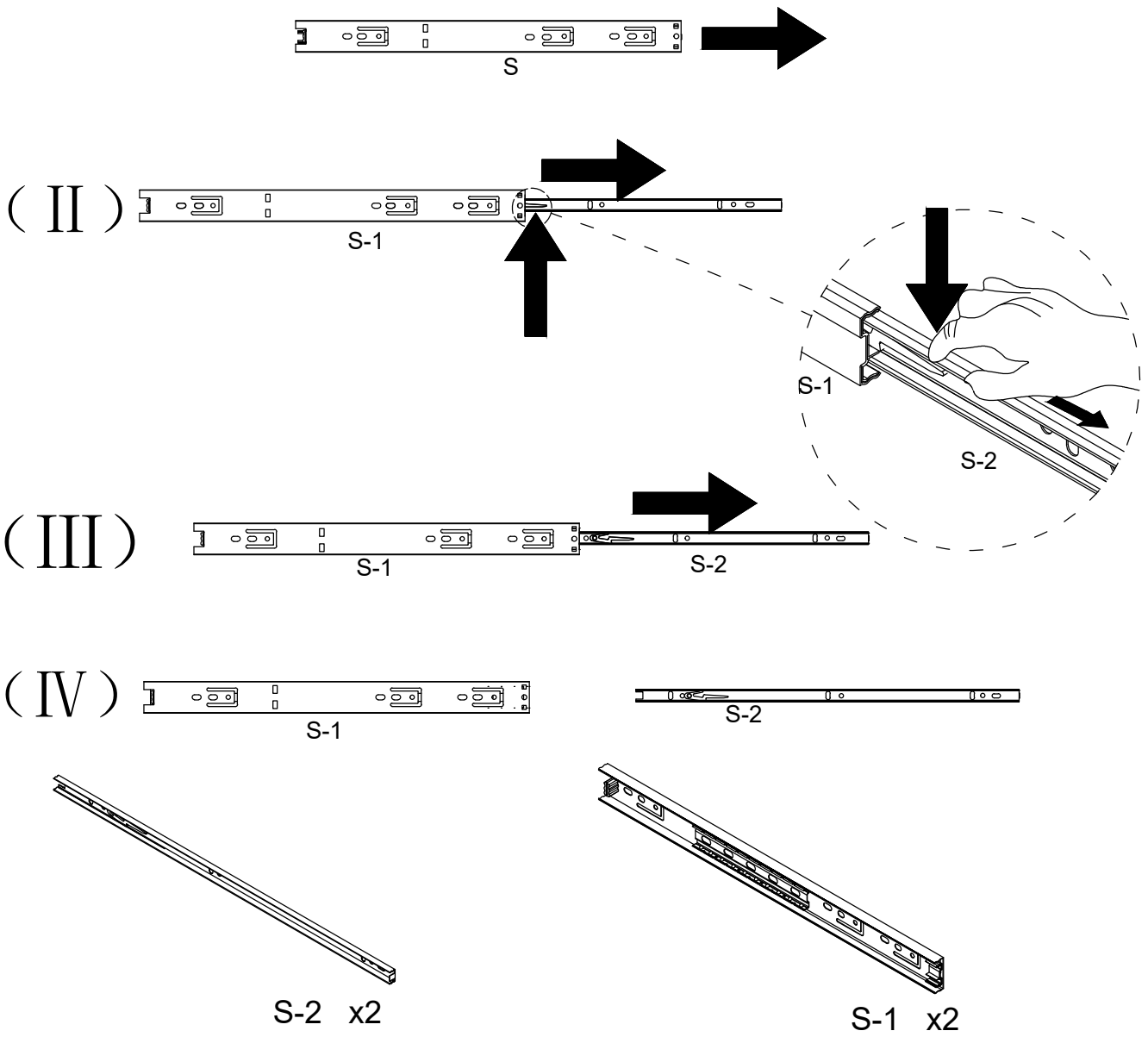
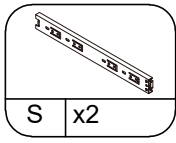

STEP 11

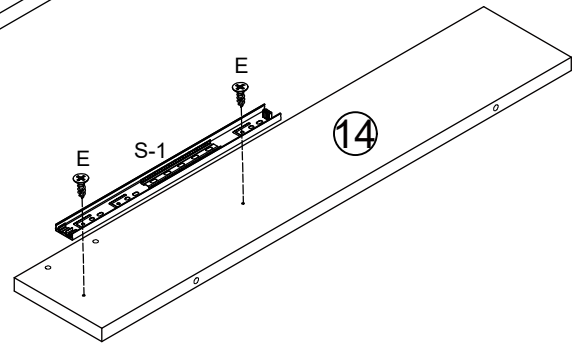
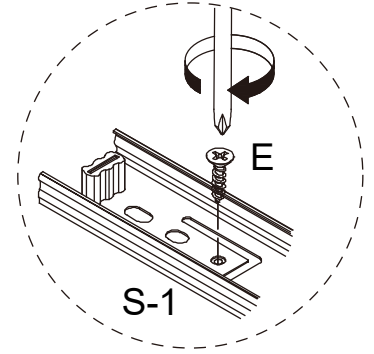
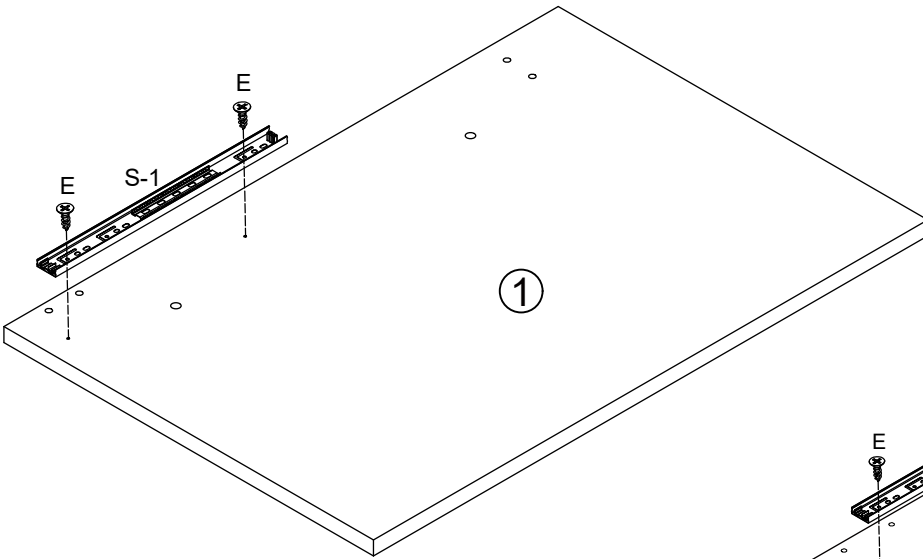
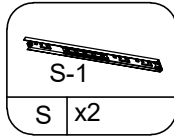
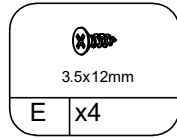
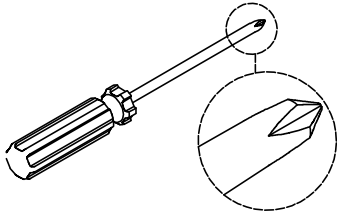

STEP 12

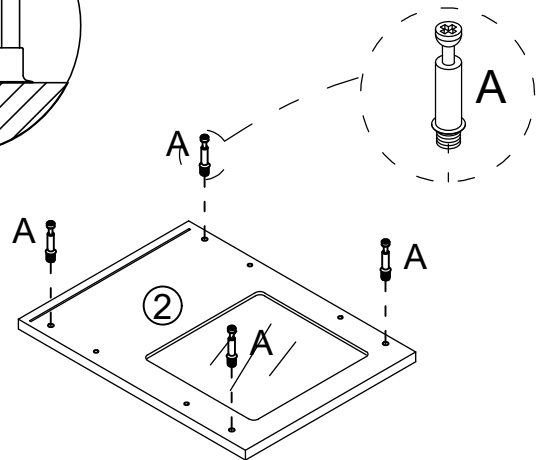
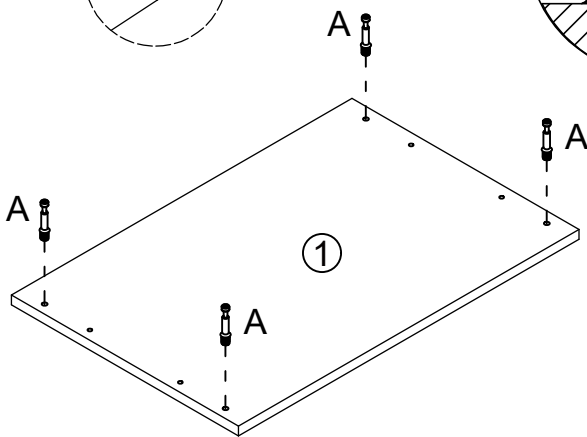
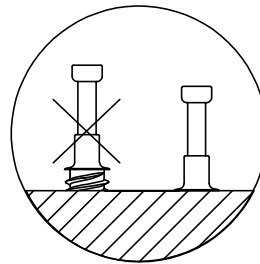
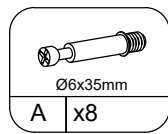
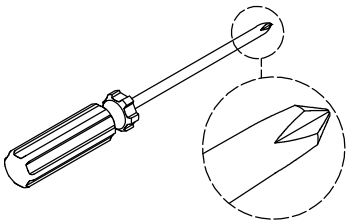

STEP 13

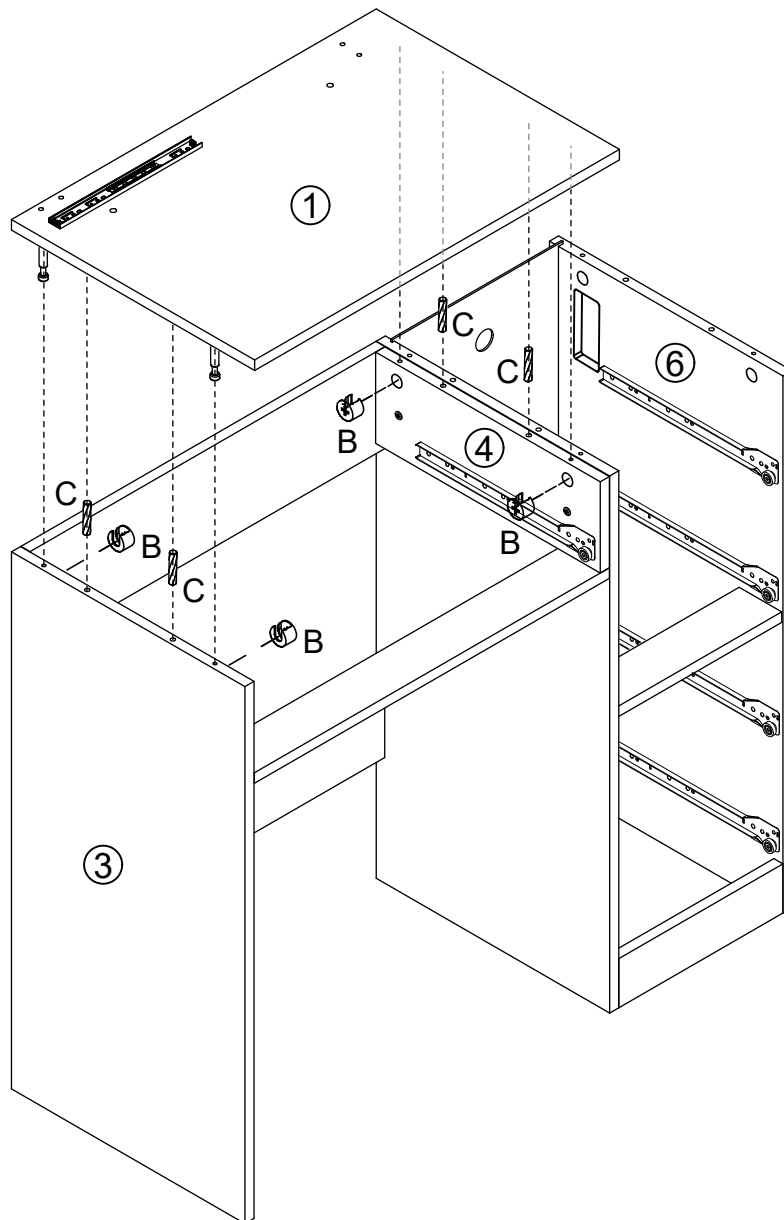
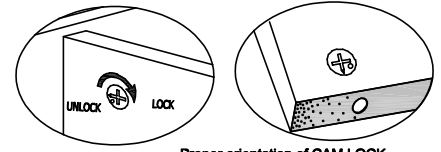
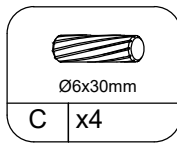
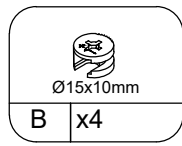
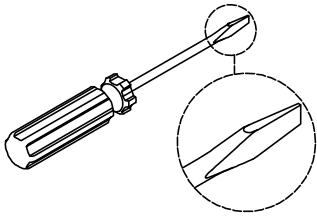

STEP 14

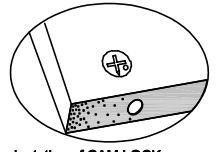
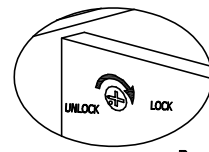
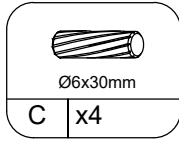
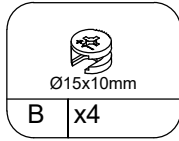
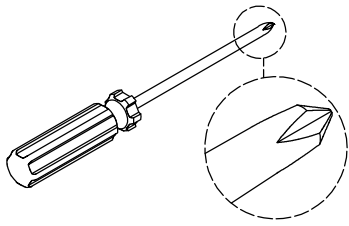

Proper orientation of CAM LOCK

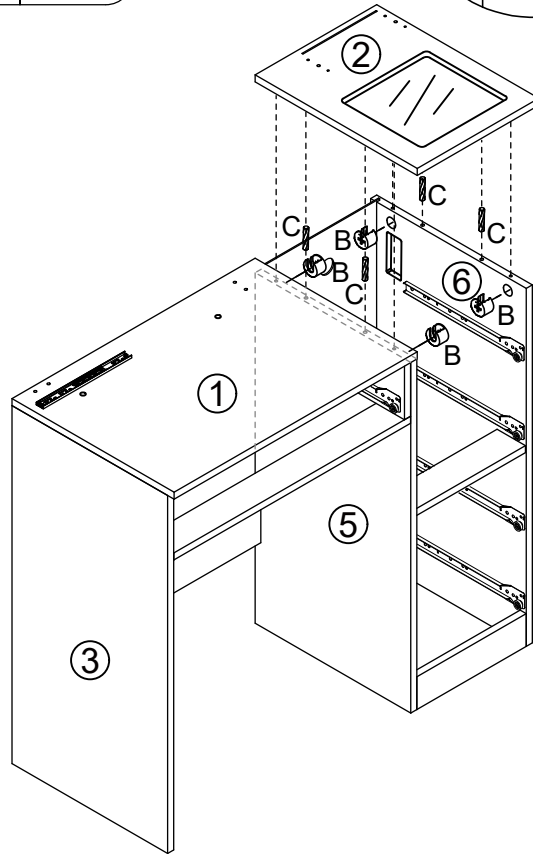

STEP 15

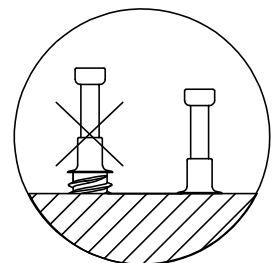
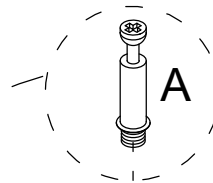
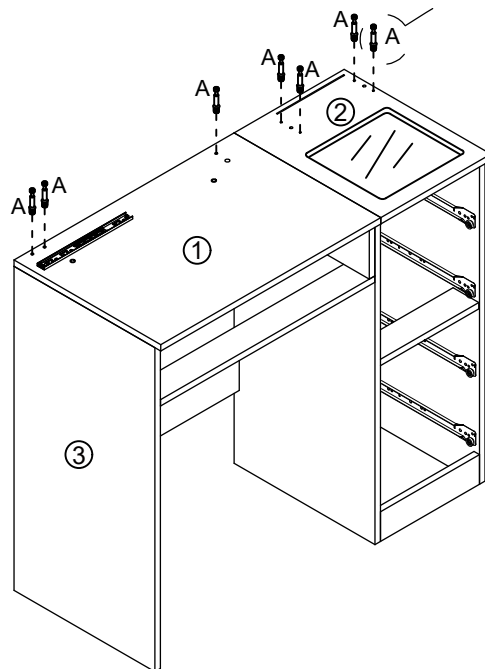
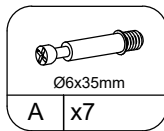
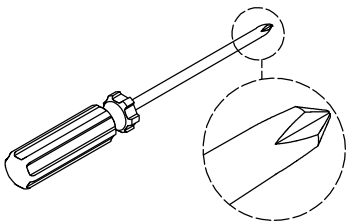

STEP 16

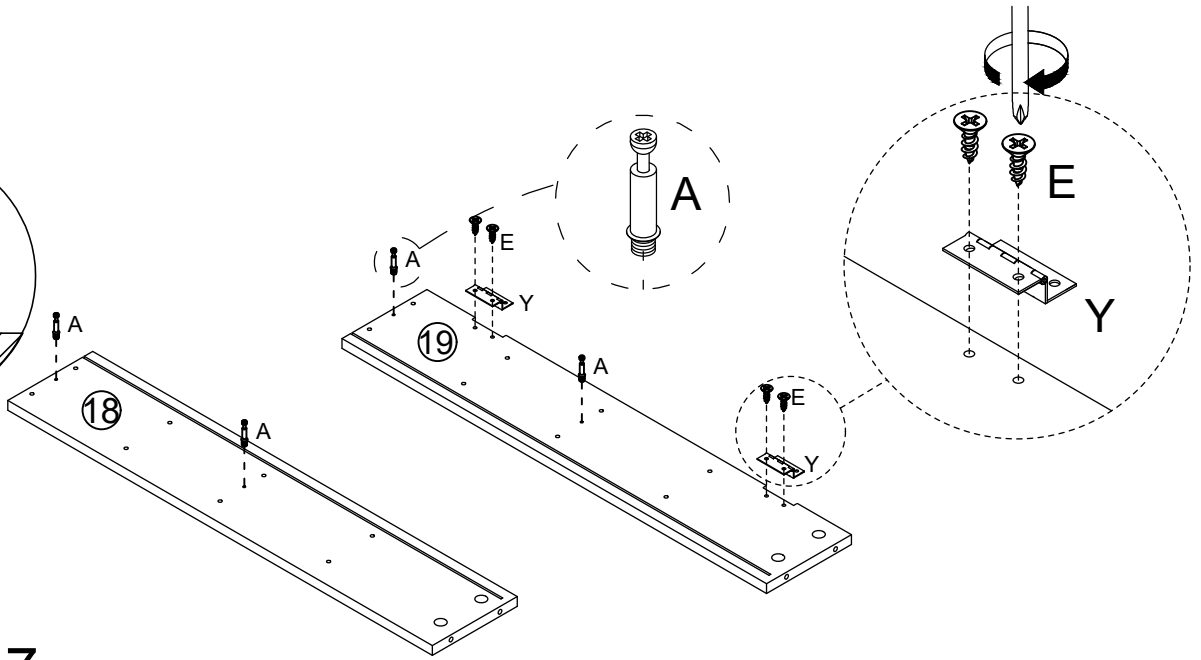
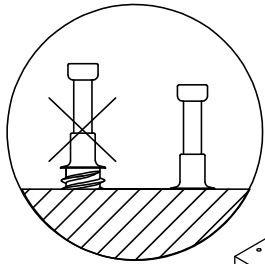
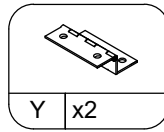
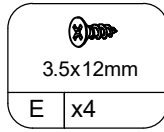
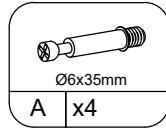
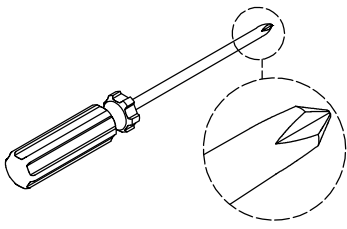

STEP 17

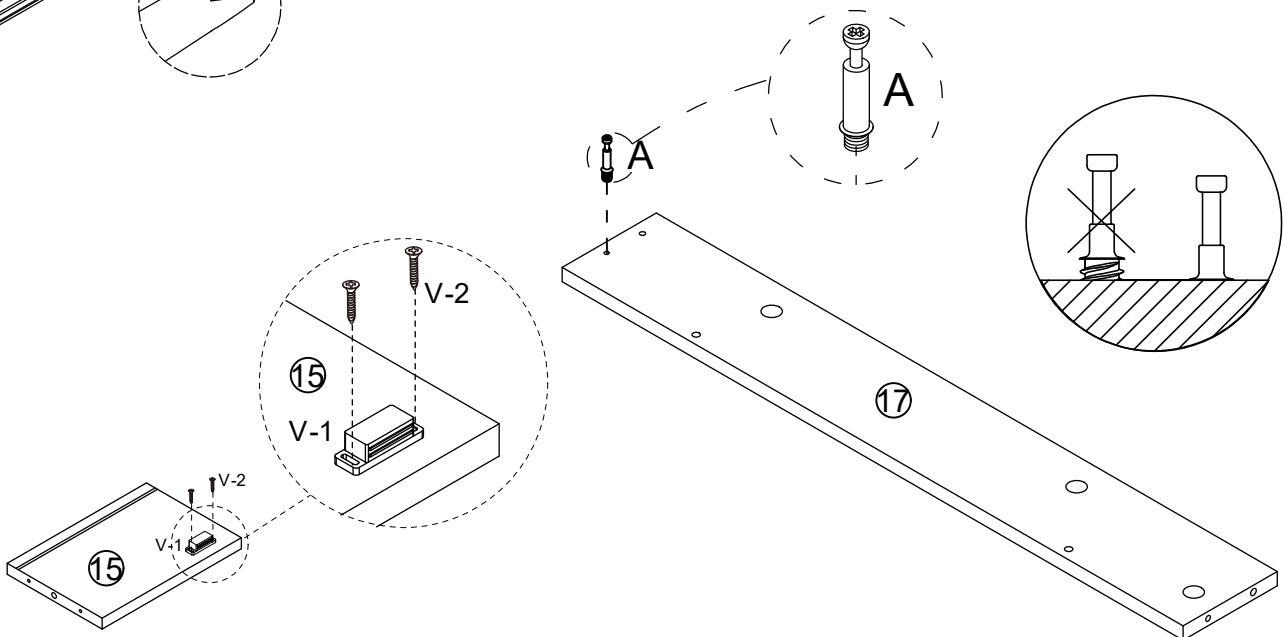
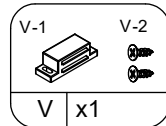
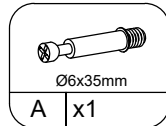
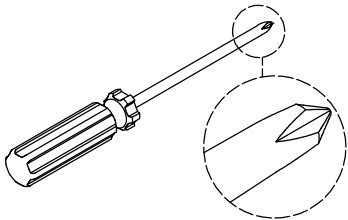

STEP 18

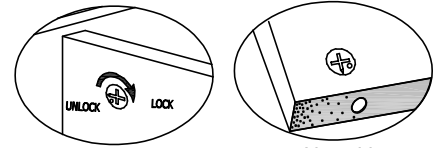
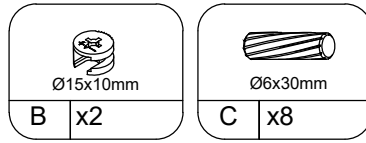
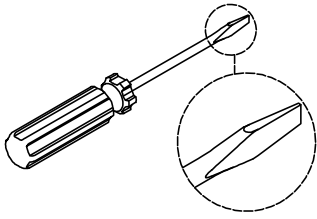

Proper orientation of CAM LOCK

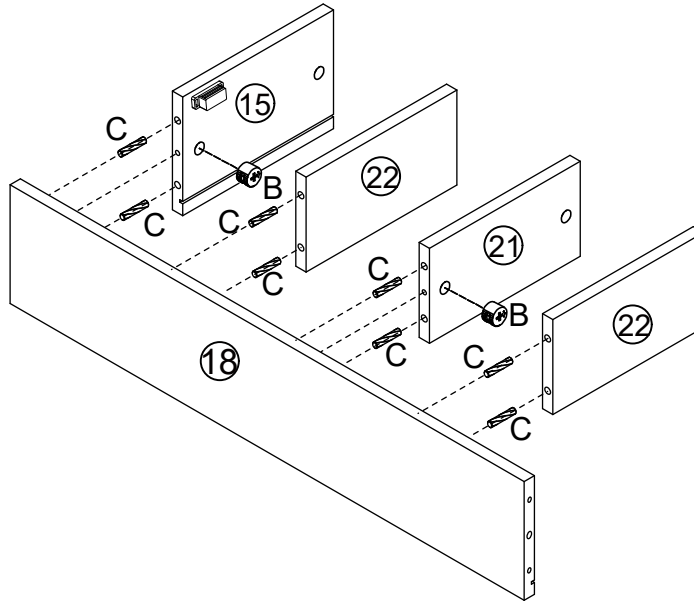

STEP 19

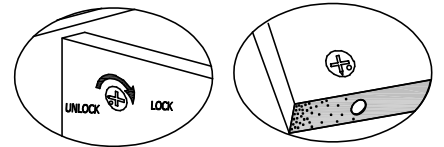
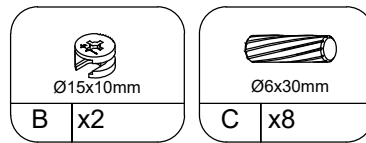
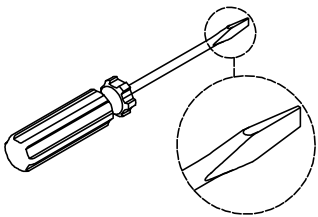

Proper orientation of CAM LOCK

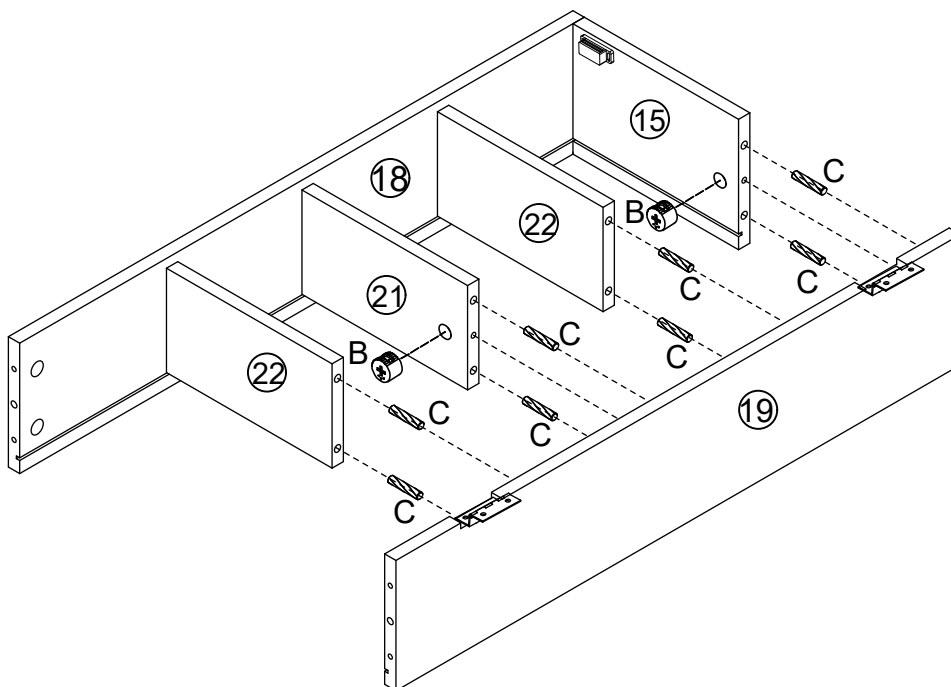

STEP 20

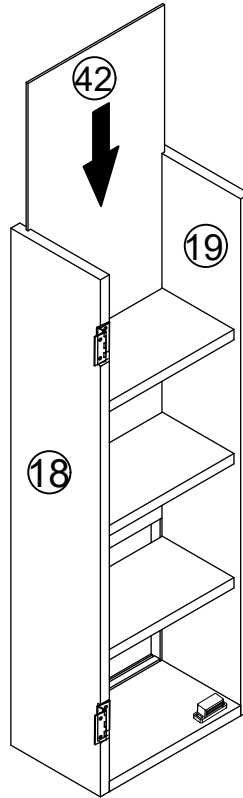

STEP 21

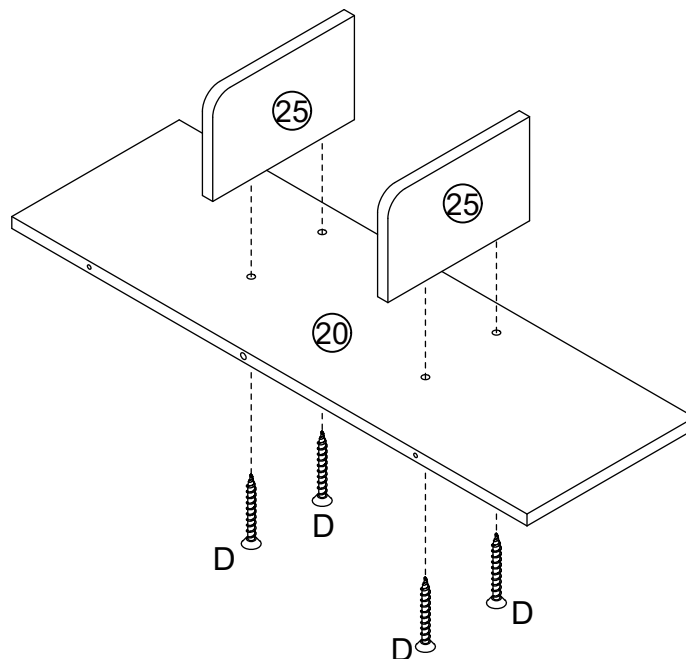
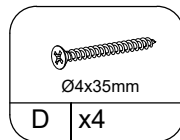
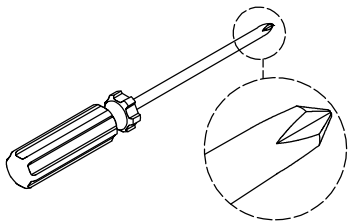

STEP 22

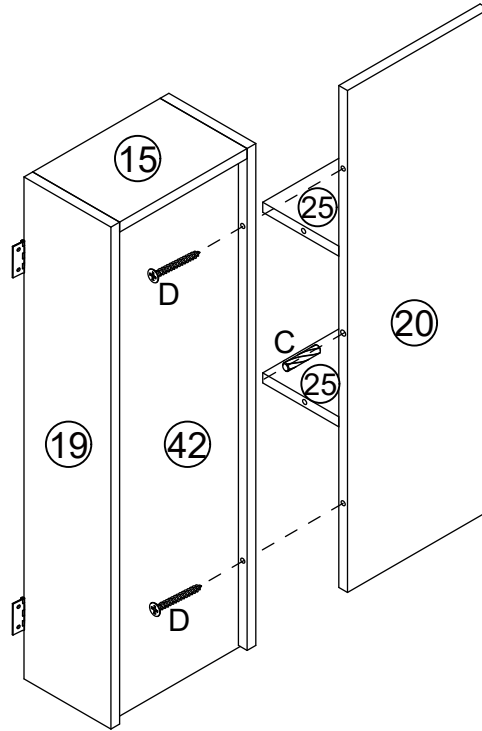
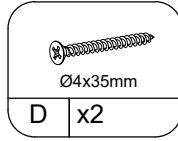
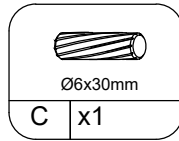
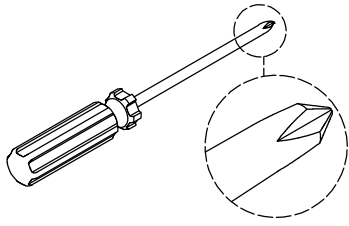

STEP 23

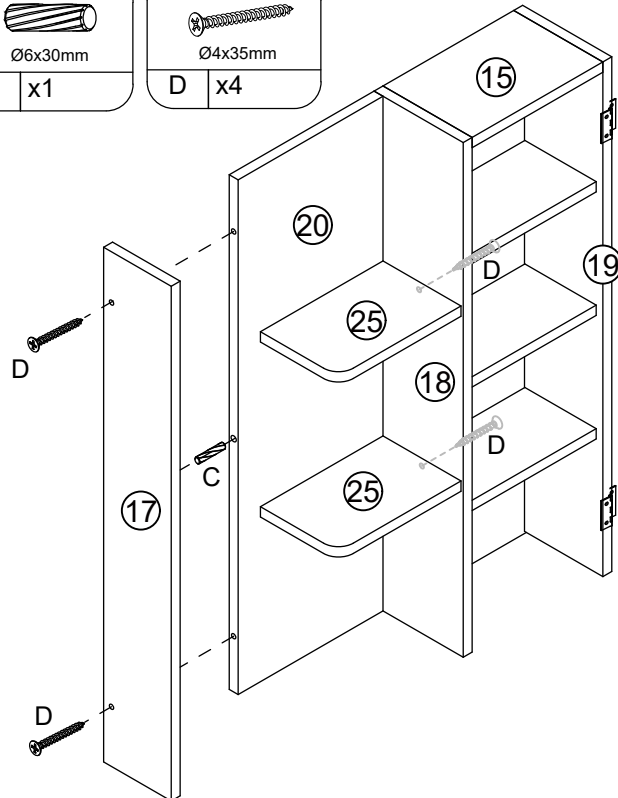
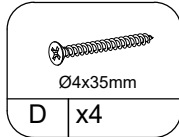
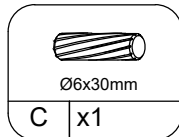
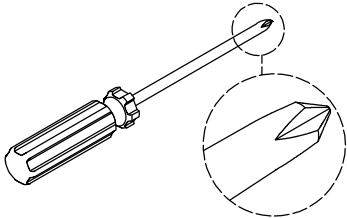

STEP 24

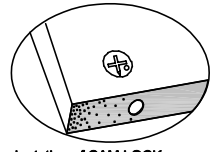
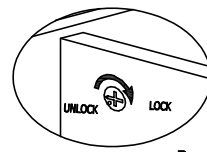
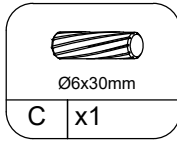
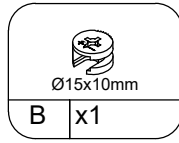
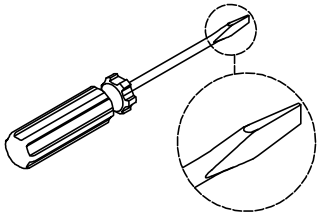

Proper orientation of CAM LOCK

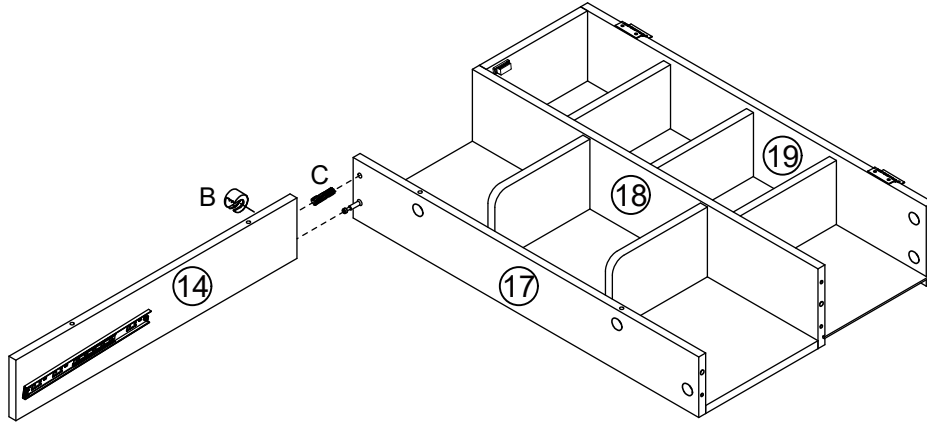

STEP 25

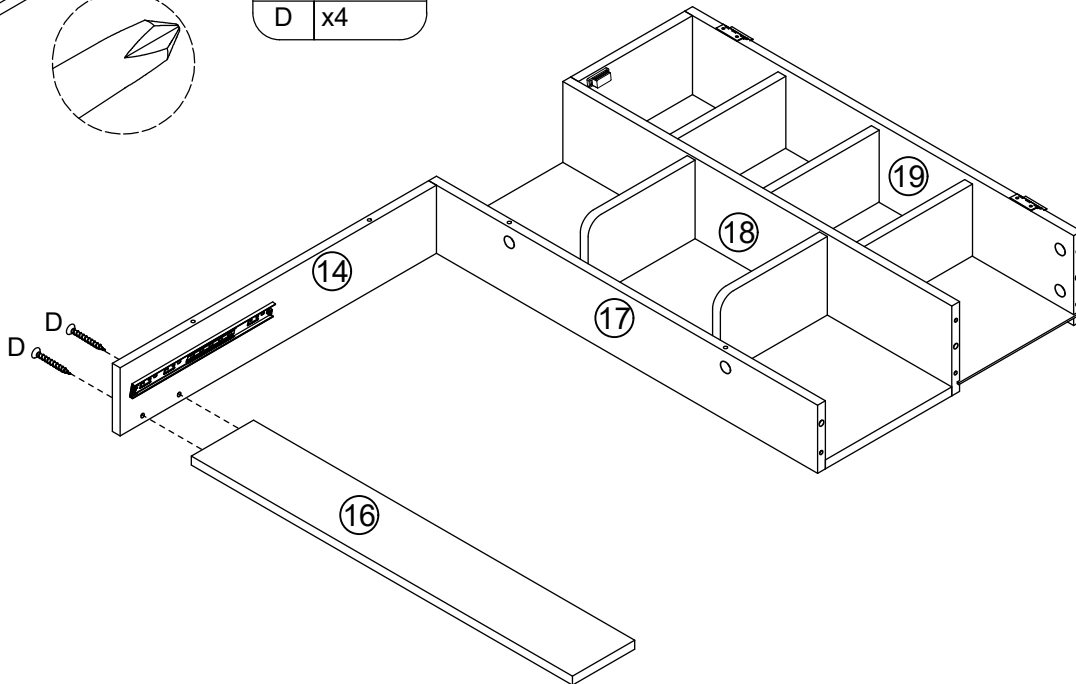
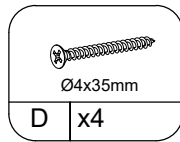
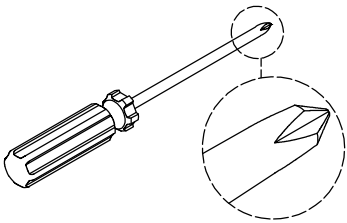

STEP 26

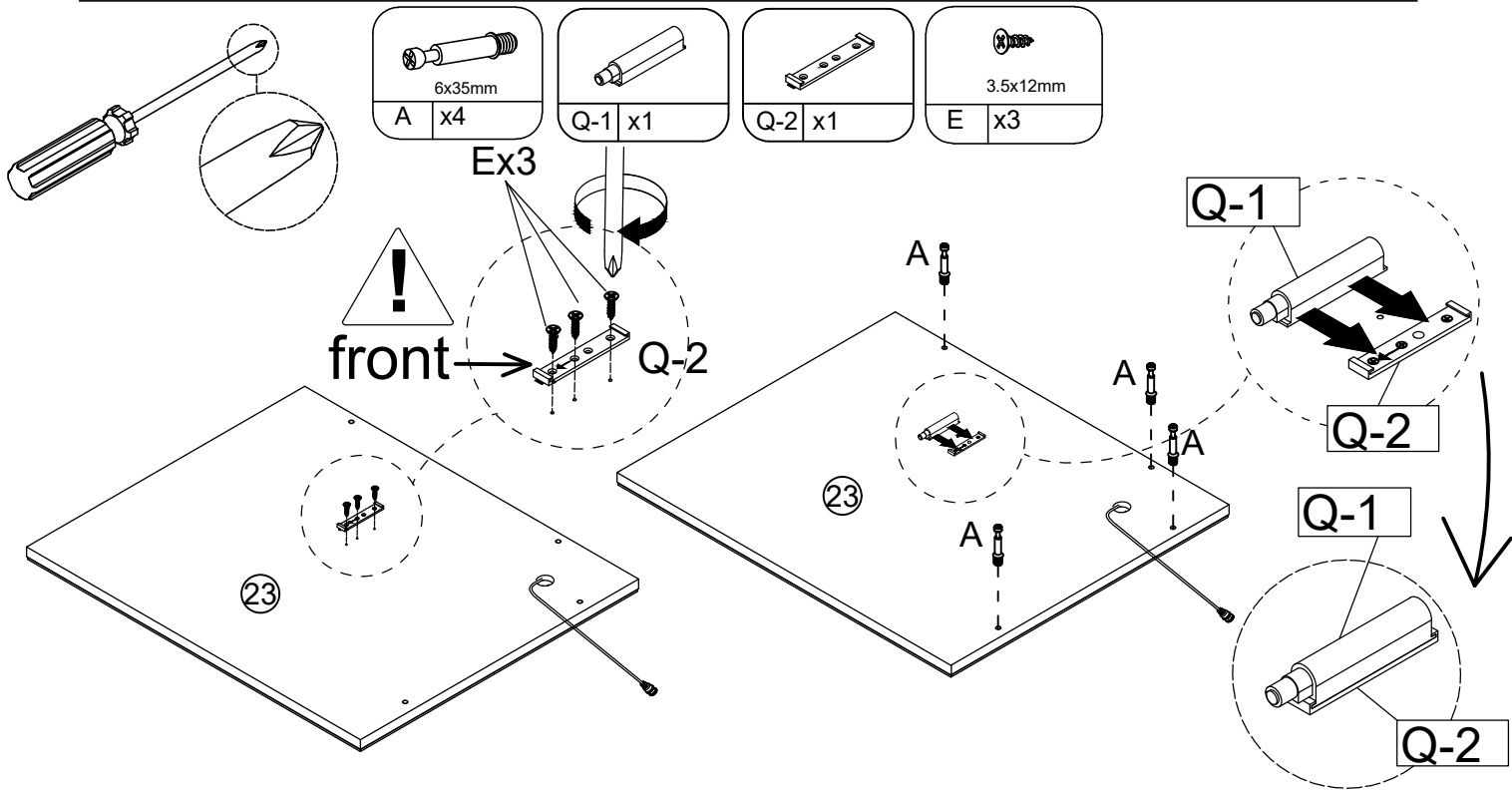

STEP 27

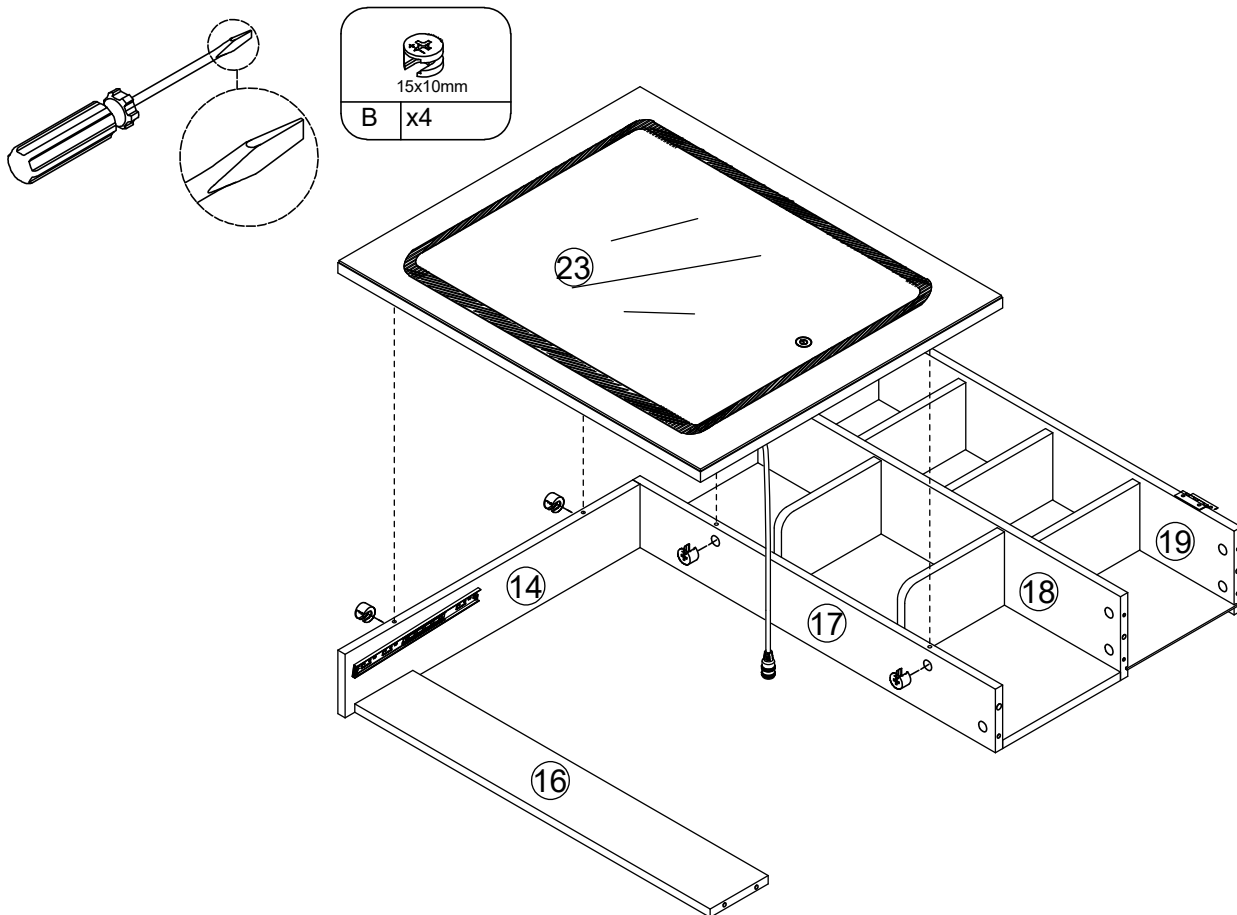

STEP 28

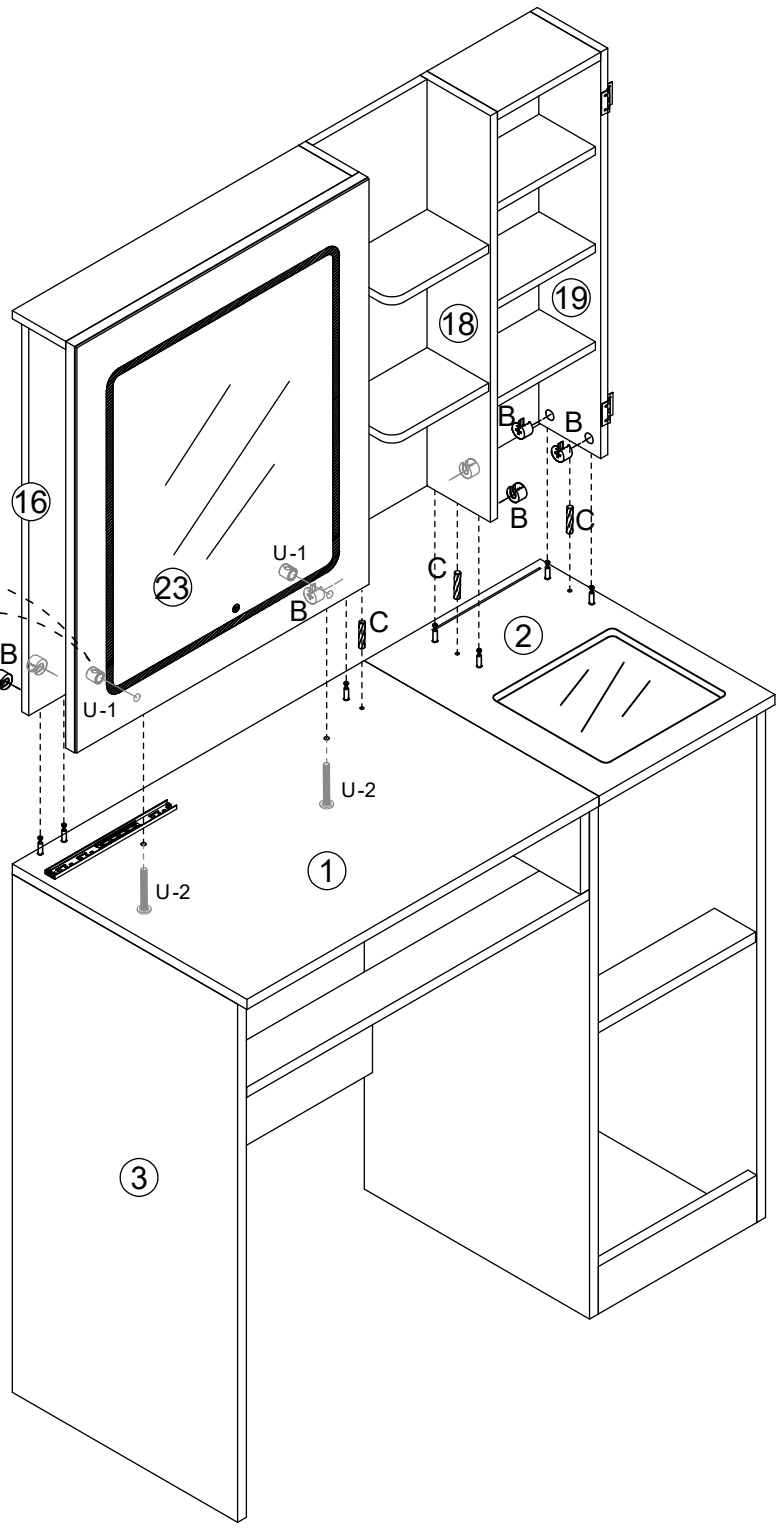
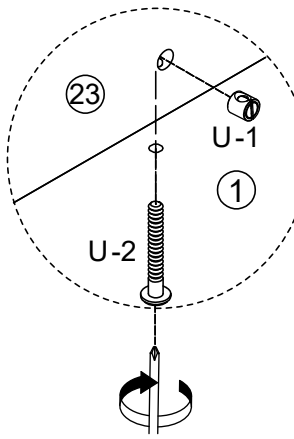
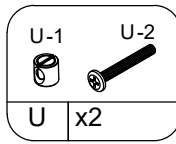
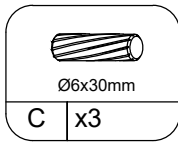
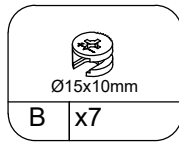
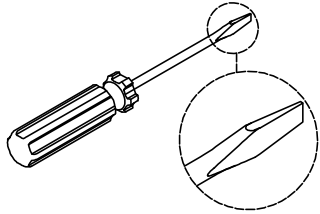
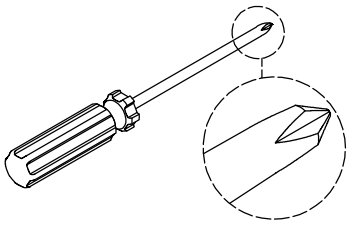

STEP 29

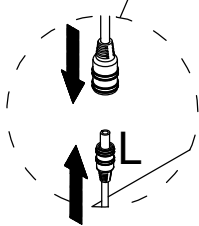
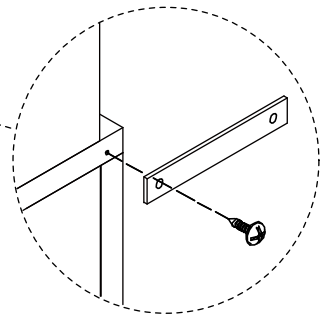
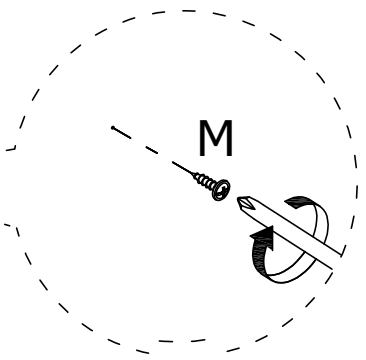
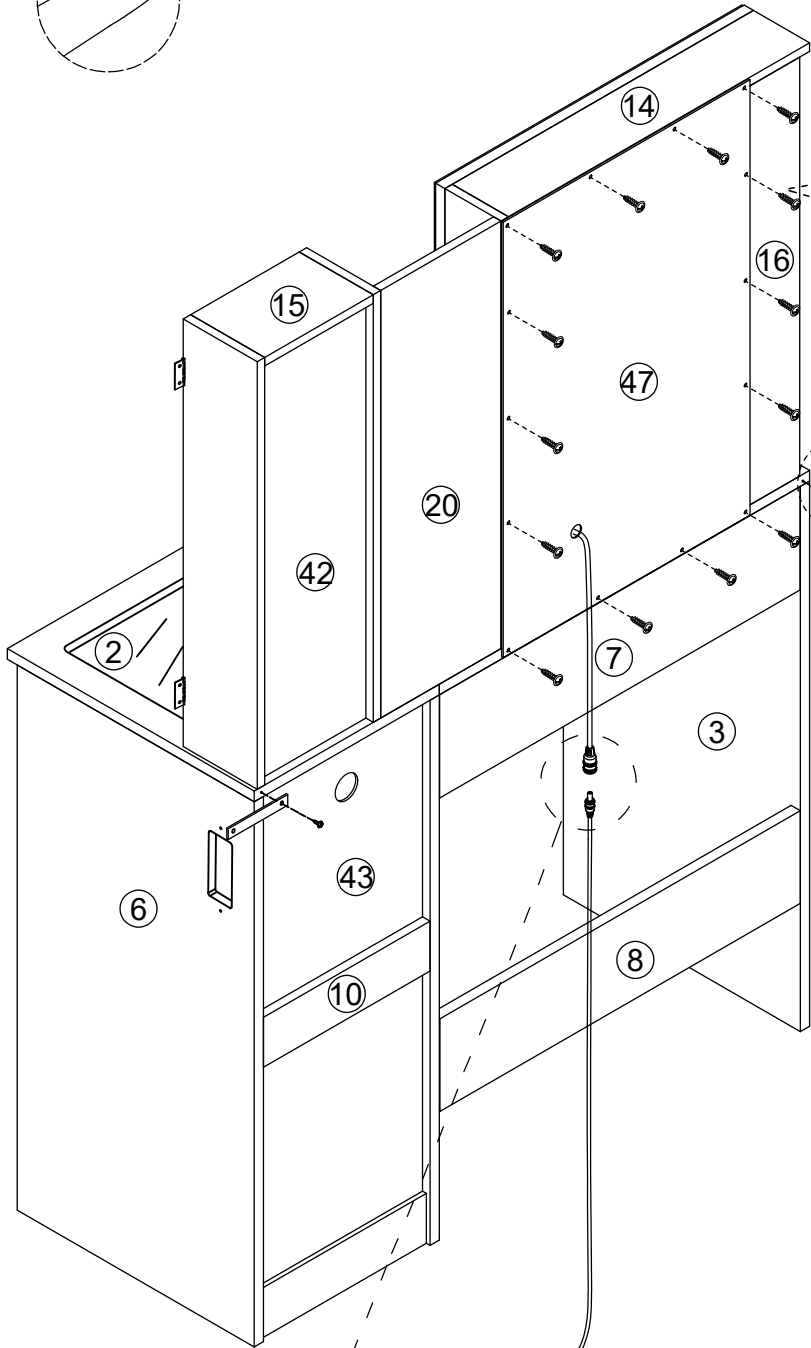
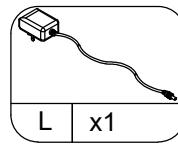
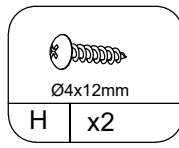
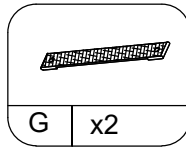
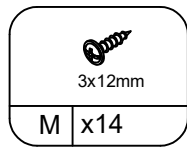
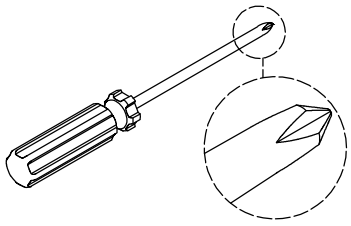

STEP 30

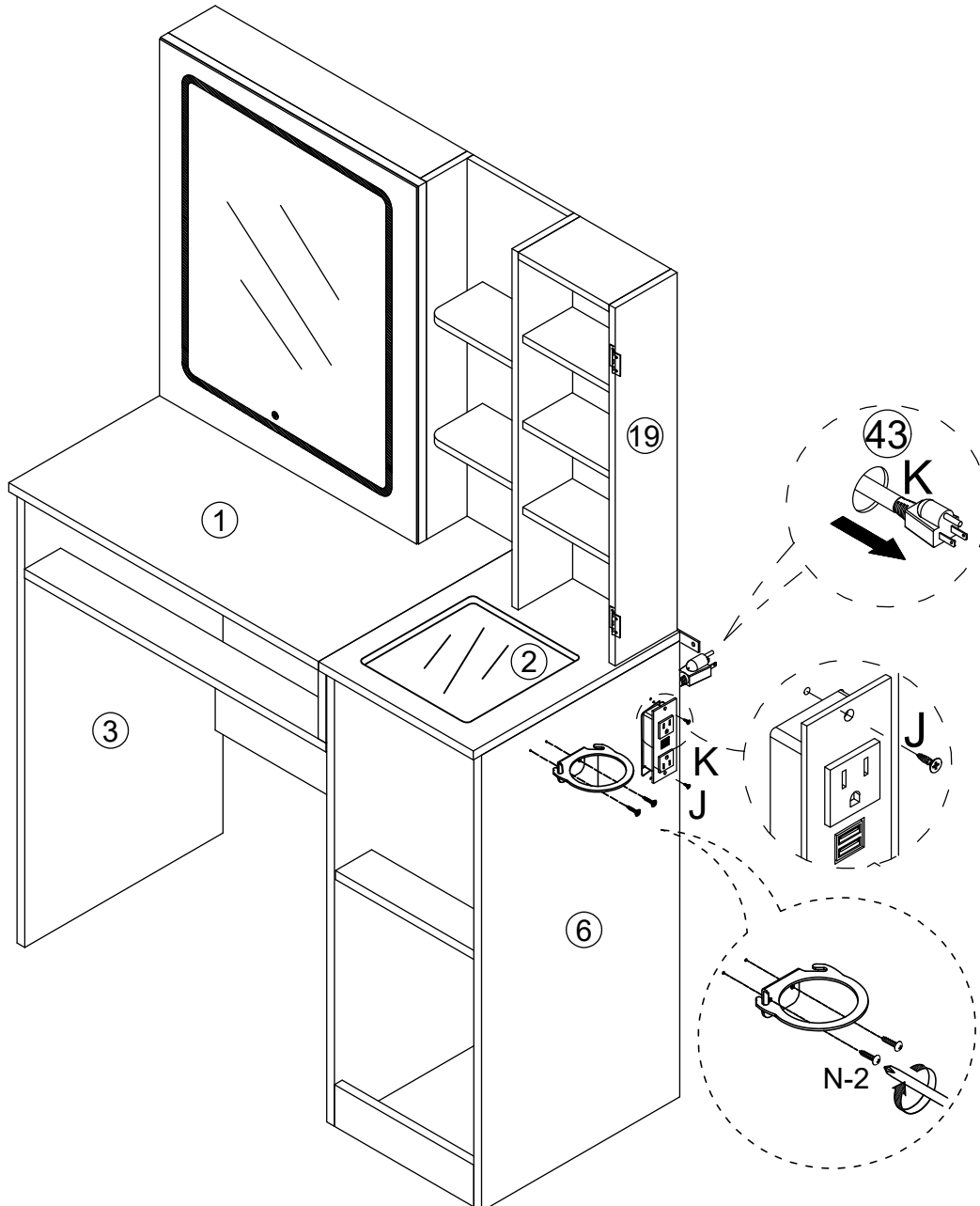
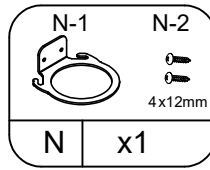
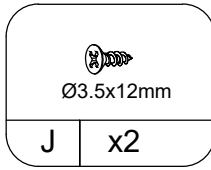
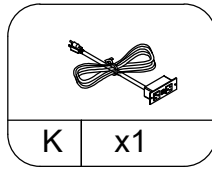
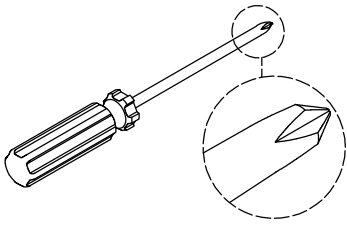

STEP 31

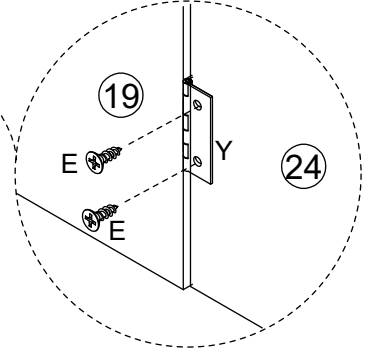
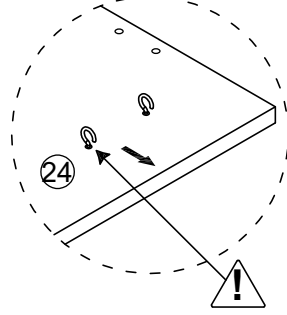
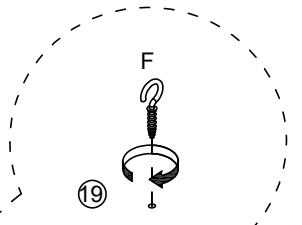
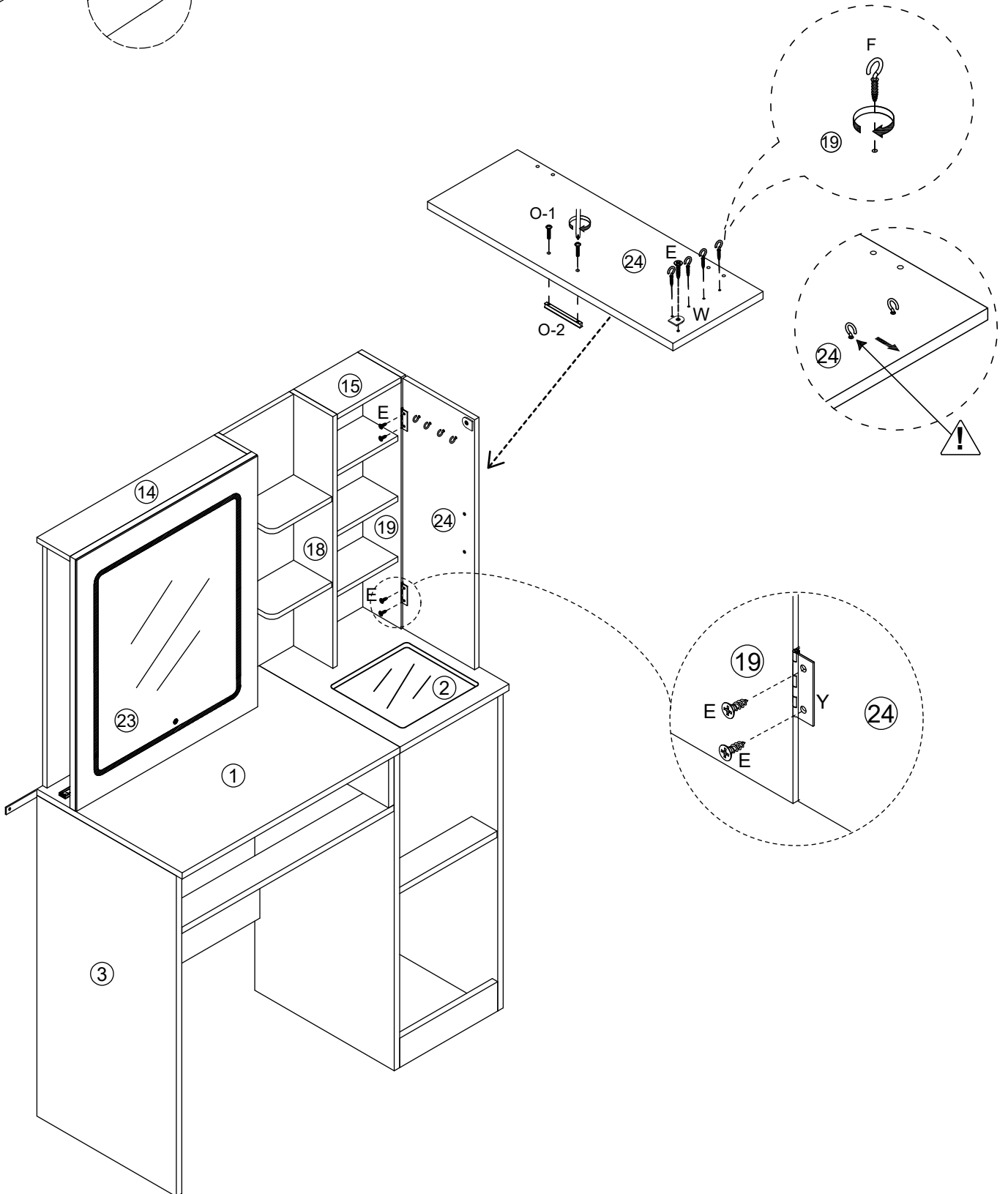
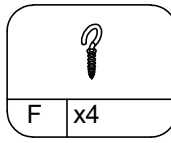
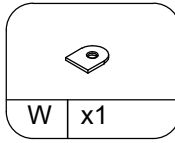
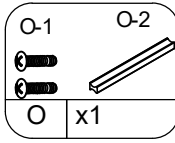
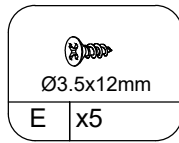
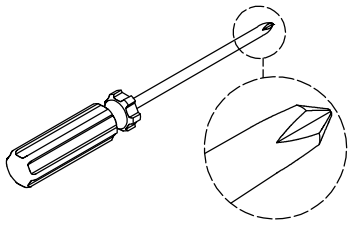

STEP 32

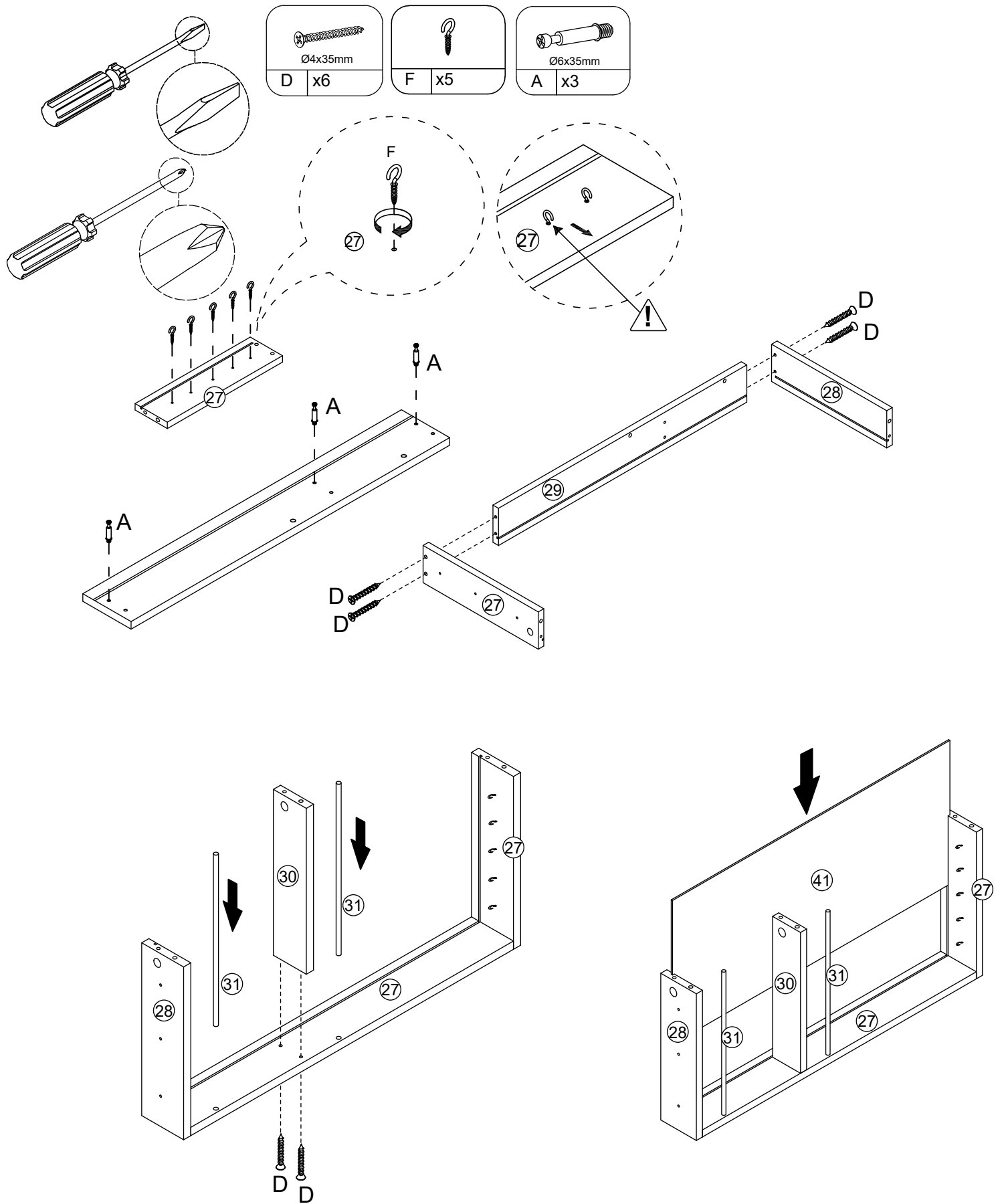

STEP 33

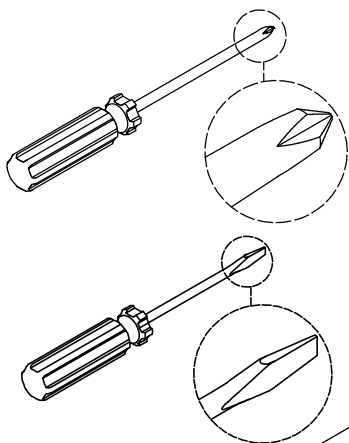

	Ø15x10mm
B	x3

	Ø6x30mm
C	x3

	3.5x12mm
E	x6

	S-2
S	x2

	Q-3
Q	x1

	3.5x10mm
T	x1

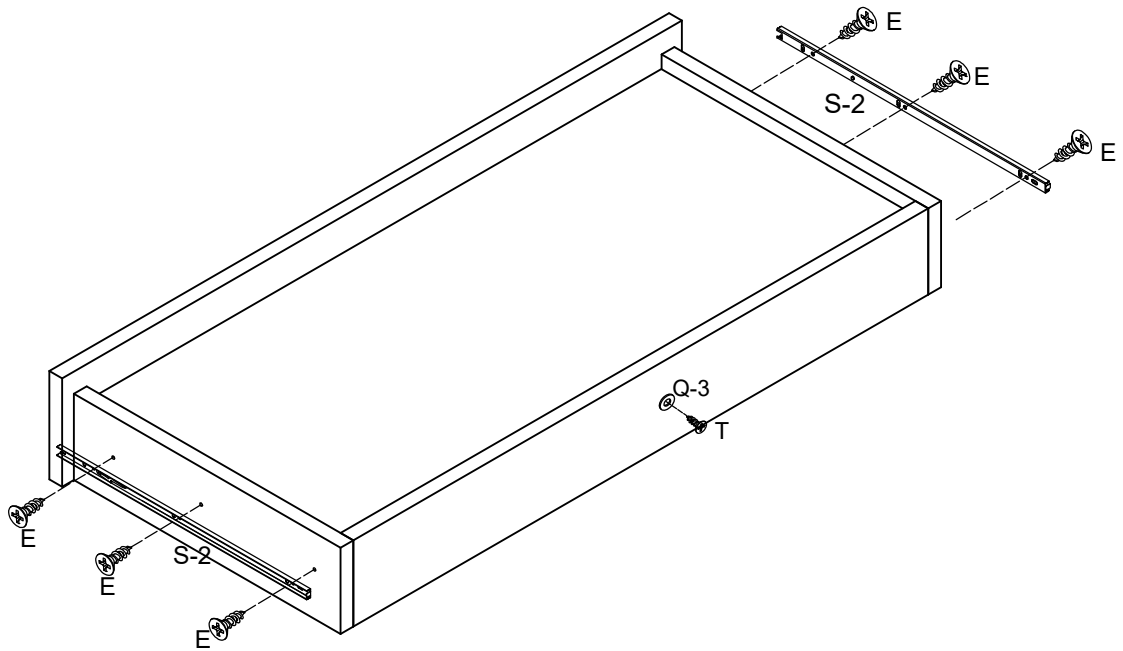
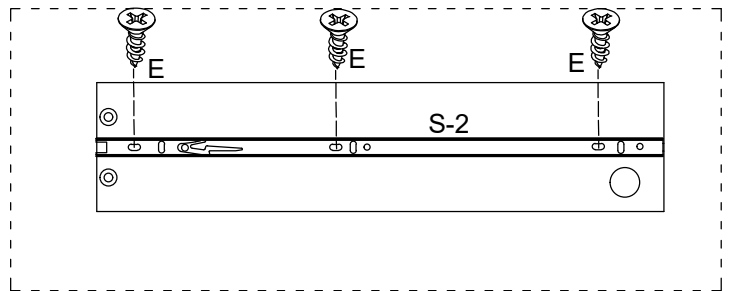
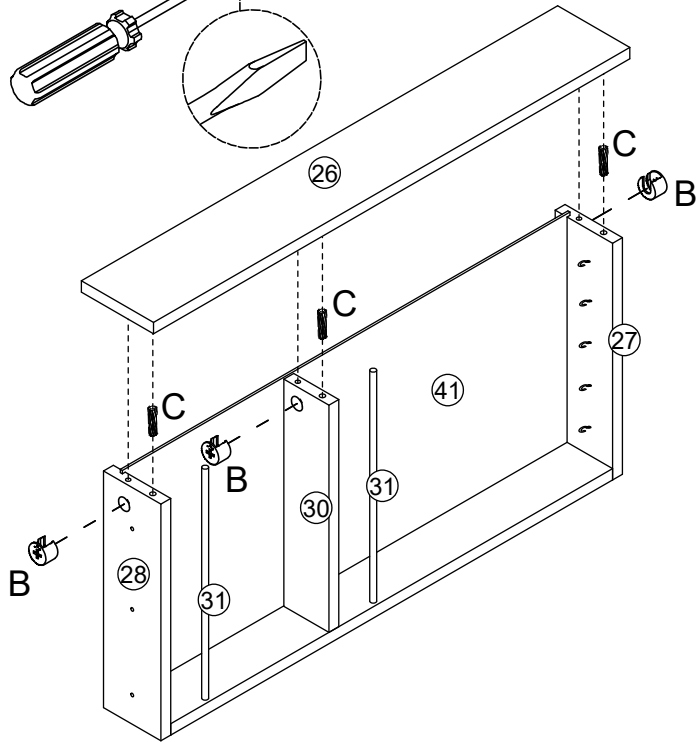

STEP 34

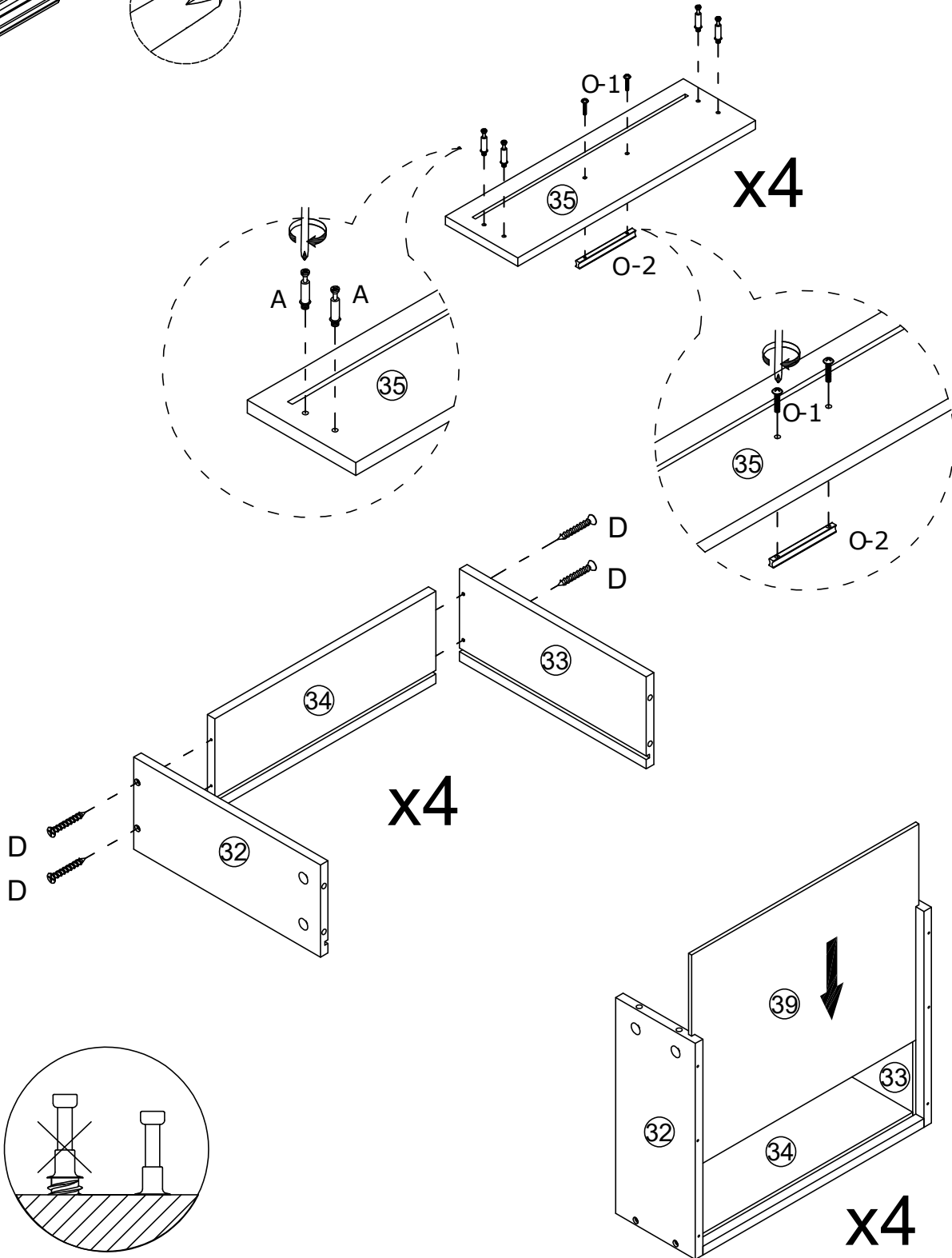
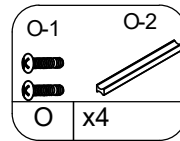
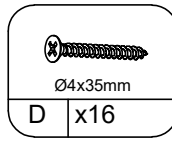
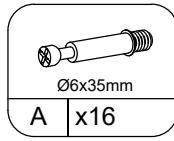
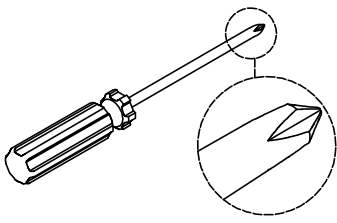

STEP 35

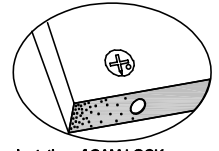
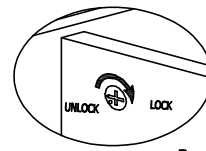
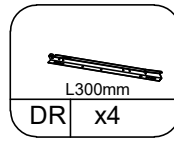
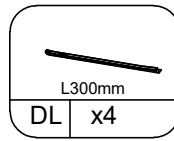
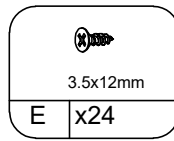
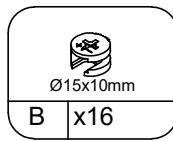
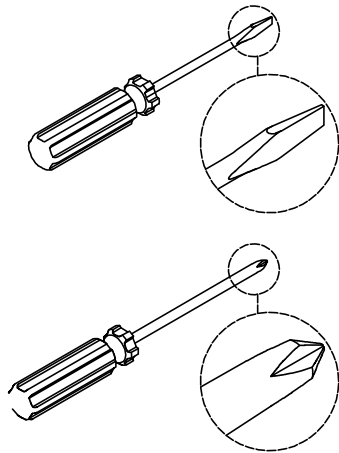

Proper orientation of CAM LOCK

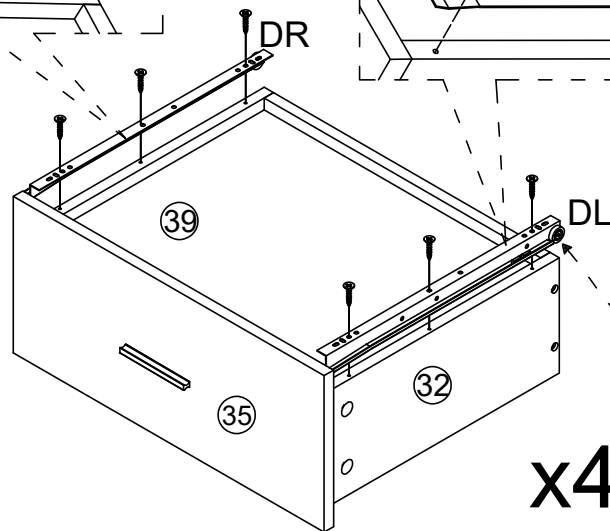
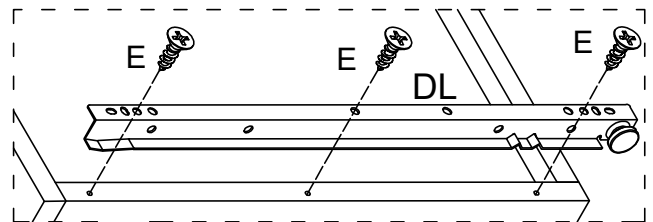
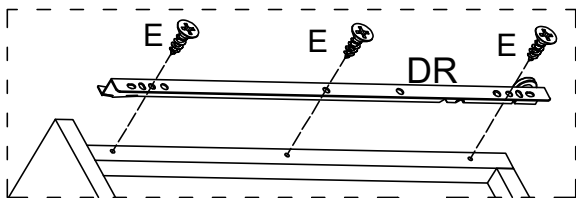
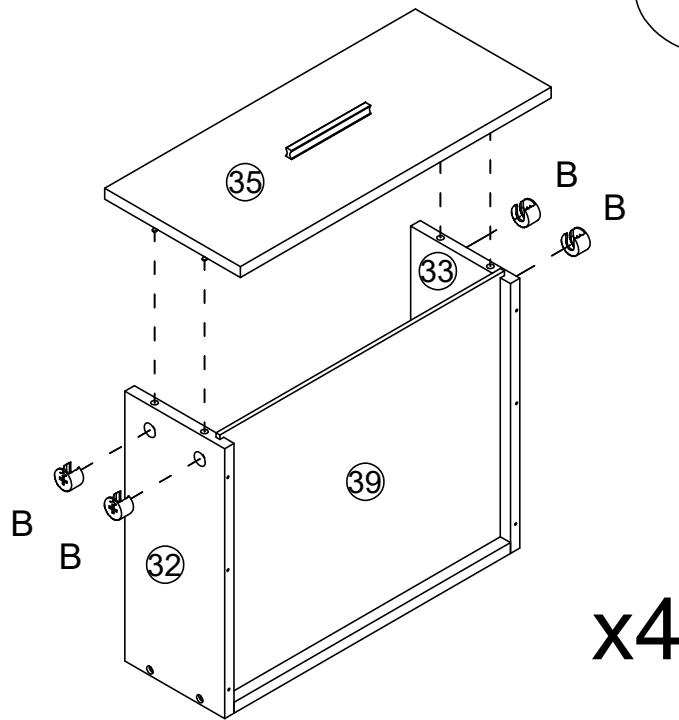

STEP 36

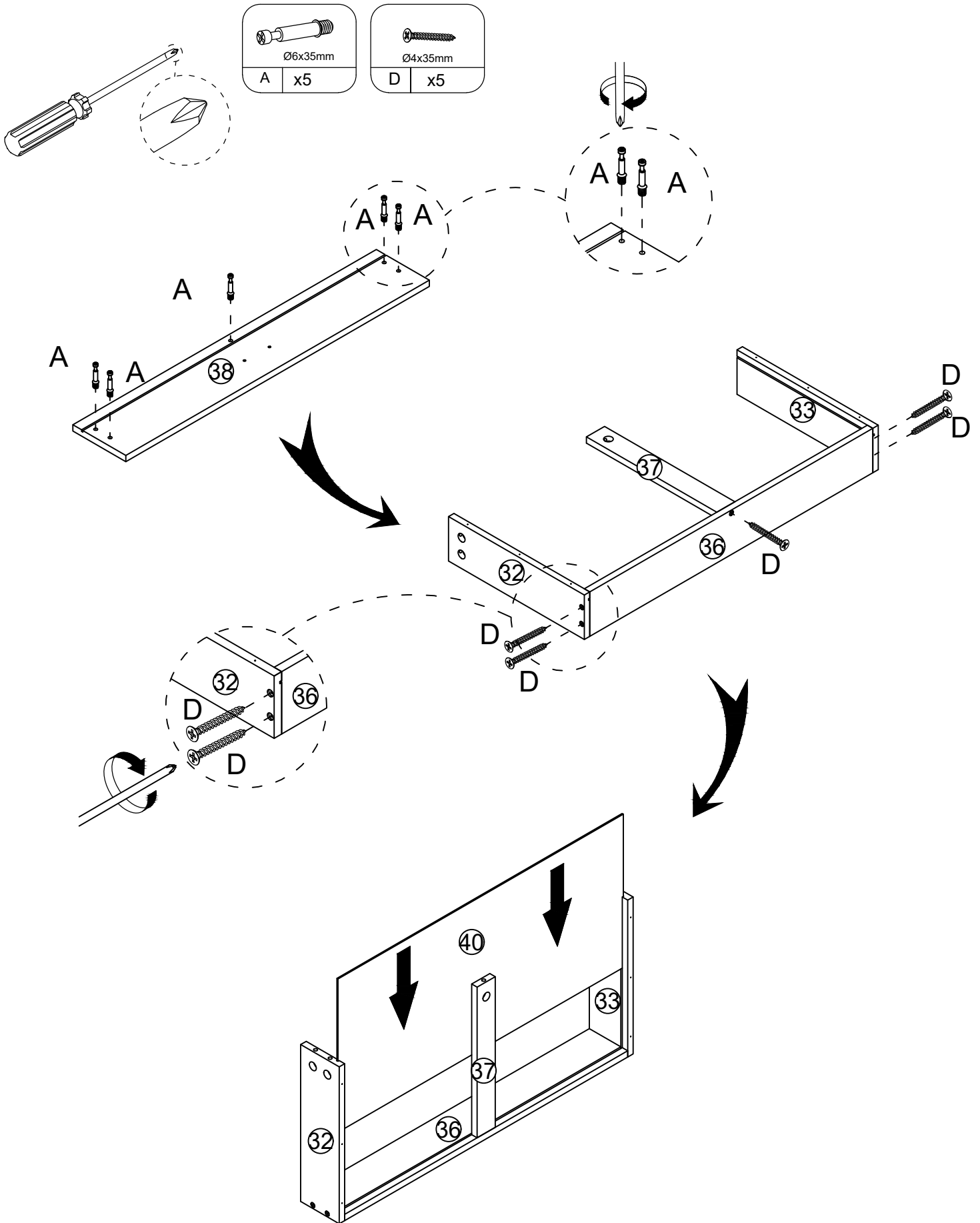

STEP 37

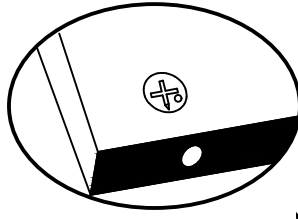
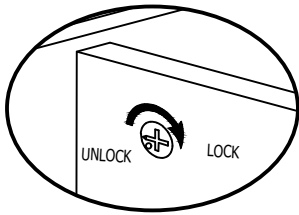
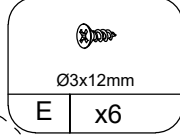
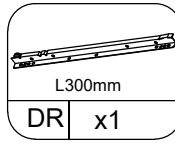
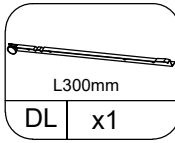
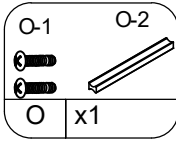
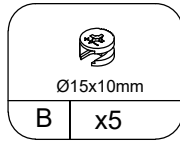

Proper orientation of CAM LOCK

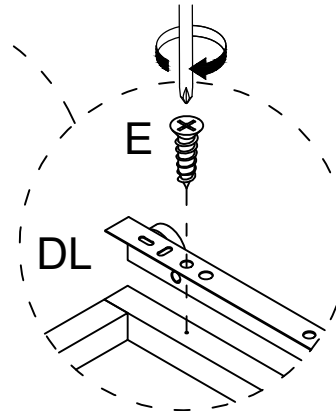
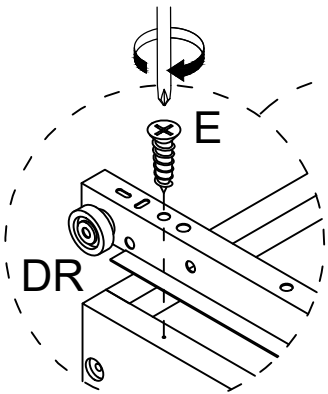
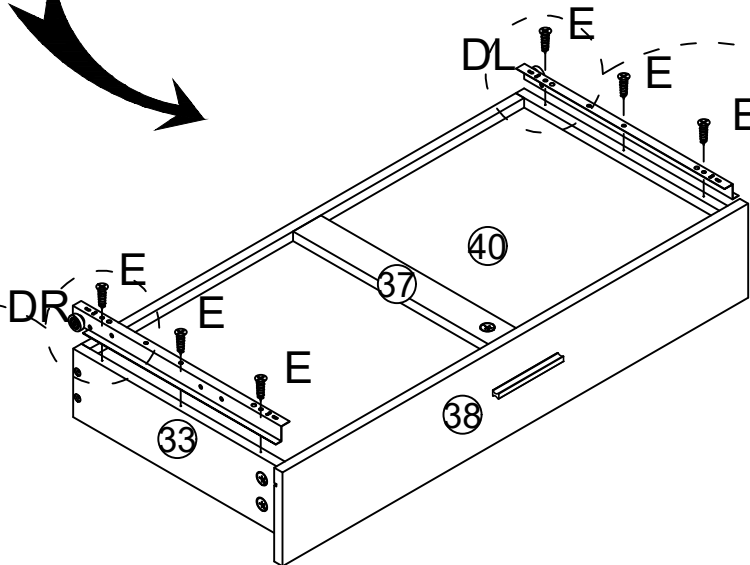
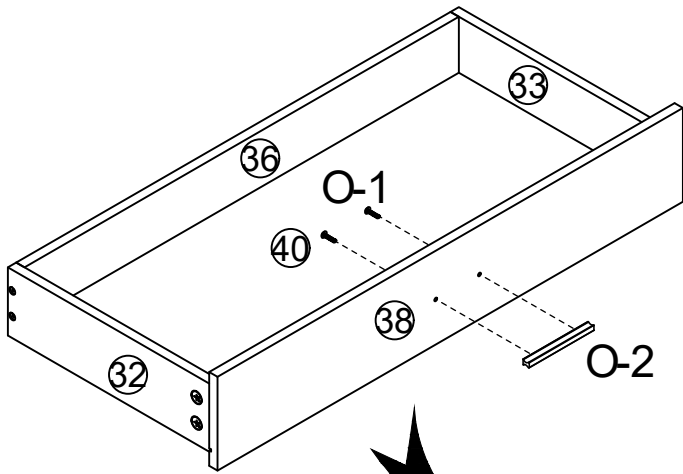
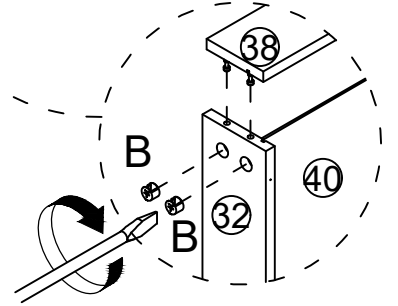
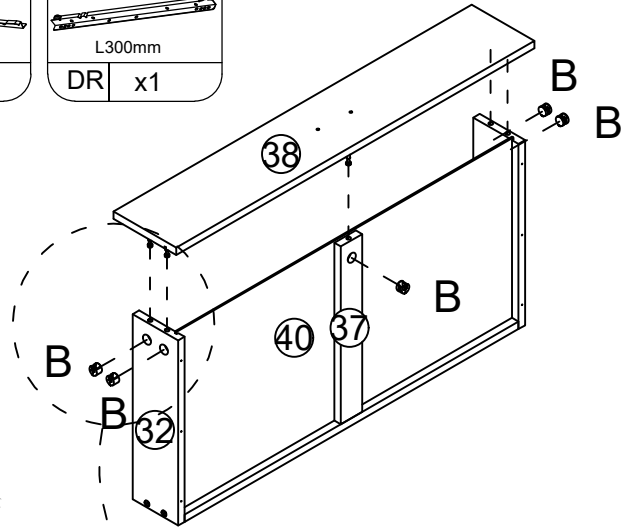

STEP 38

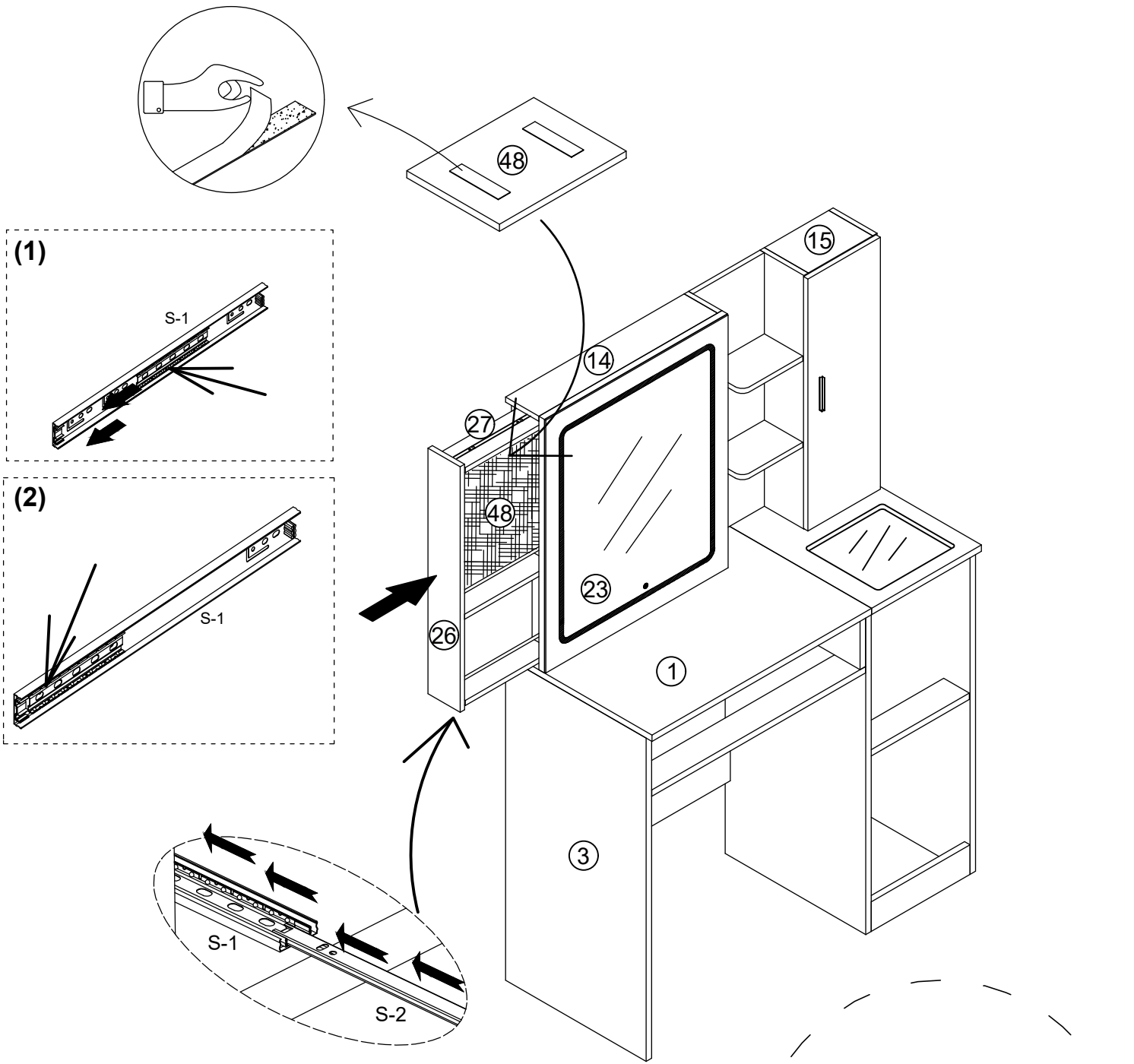



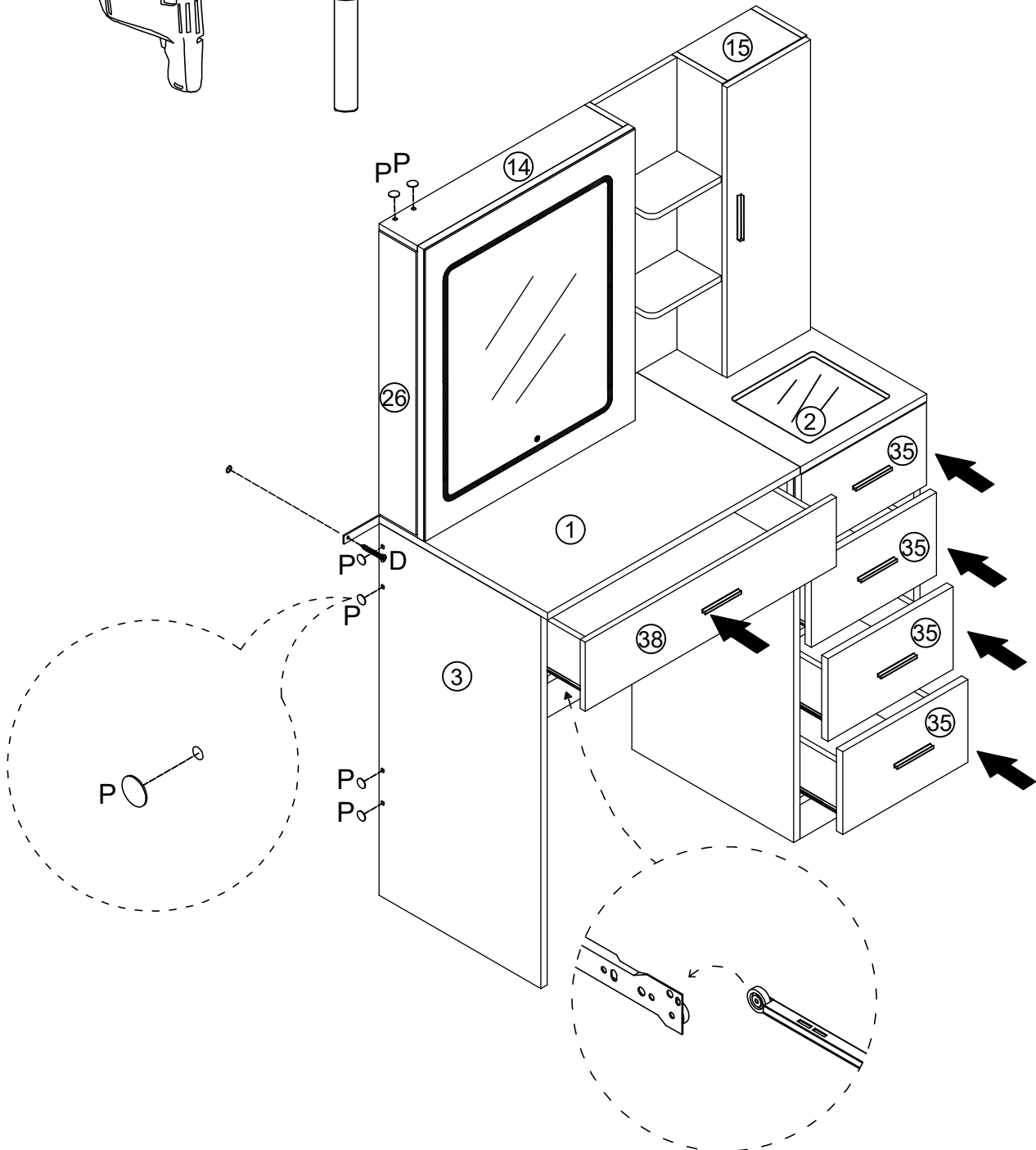
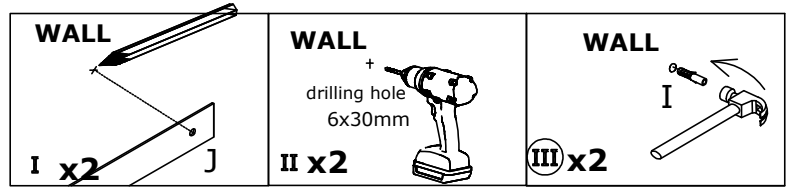
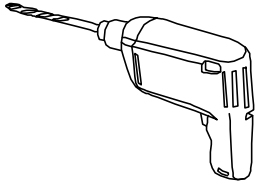
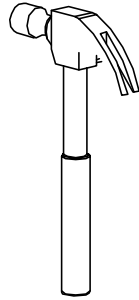
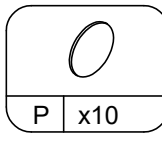
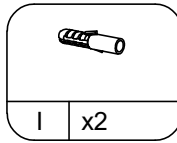
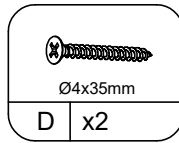
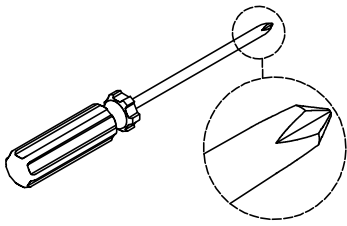

If you find that the elastomer can not be adsorbed when the installation is incomplete, please adjust here a little, as shown

STEP 39

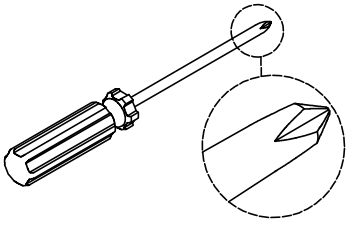

STEP 40



 R x4	 Ø4x12mm H x8	 Ø6x30mm C x4	 Ø4x35mm D x8
---	--	---	--

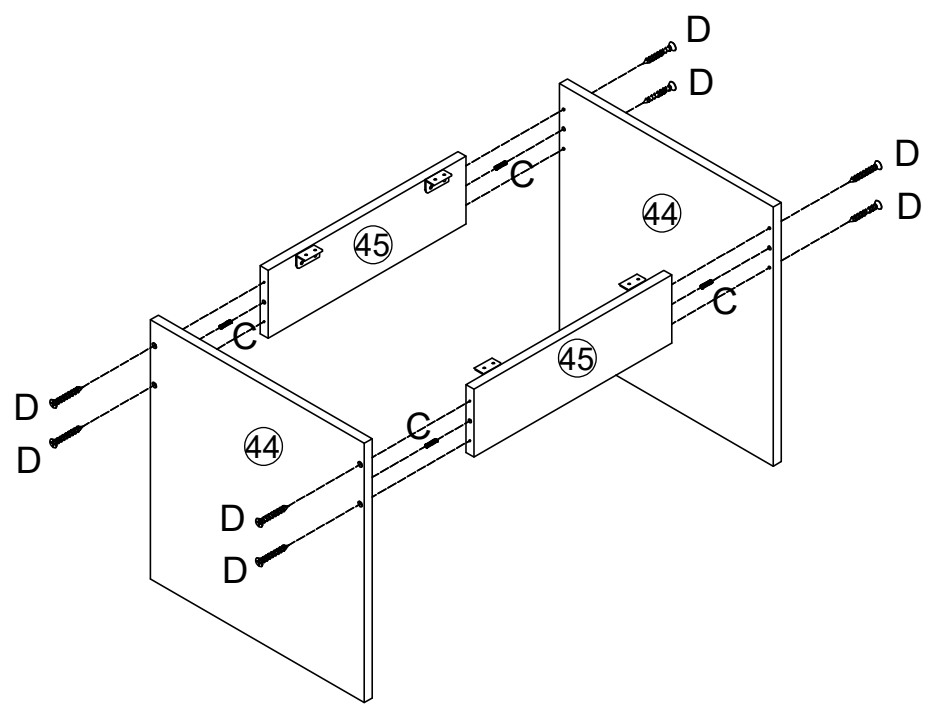
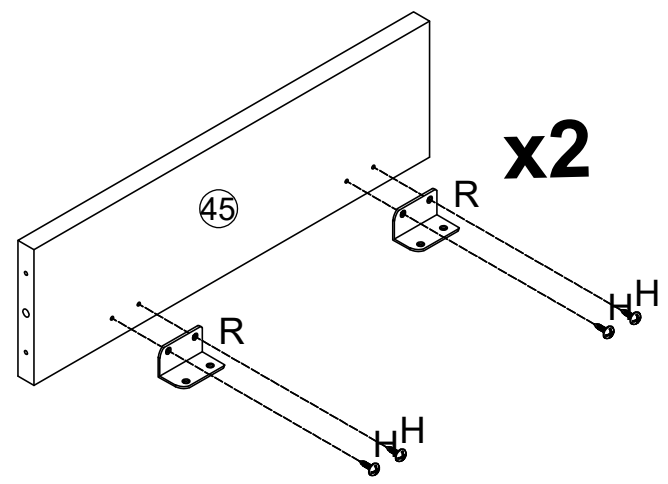

STEP 41

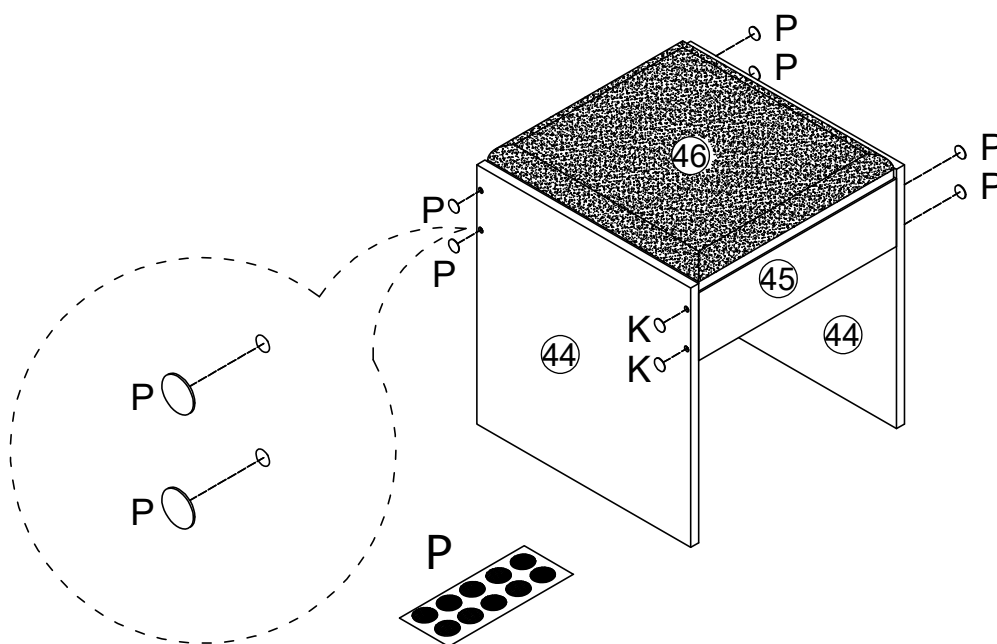
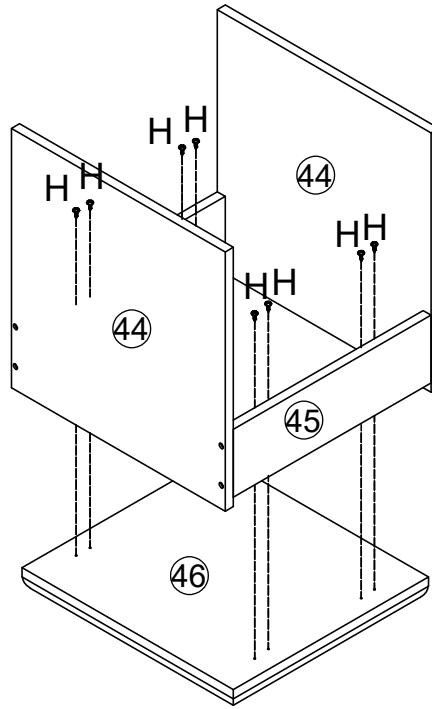
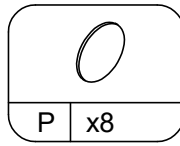
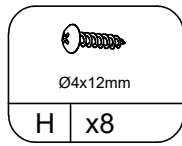
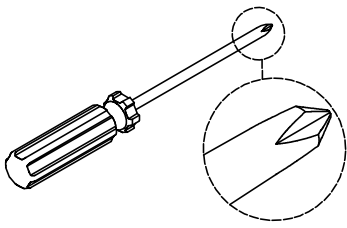

STEP 42

